

FCC Test Report

Report No.: RF200522E11-1

FCC ID: 2AWHPR201

Test Model: UTR-201

Received Date: May 25, 2020

Test Date: June 11 to 30, 2020

Issued Date: July 09, 2020

Applicant: Space Exploration Technologies Corp.

Address: 1 Rocket Rd., Hawthorne, CA 90250 USA

Issued By: Bureau Veritas Consumer Products Services (H.K.) Ltd., Taoyuan Branch
Hsin Chu Laboratory

Lab Address: E-2, No.1, Li Hsin 1st Road, Hsinchu Science Park, Hsinchu City 300,
Taiwa.

Test Location: E-2, No.1, Li Hsin 1st Road, Hsinchu Science Park, Hsinchu City 300,
Taiwan.

**FCC Registration /
Designation Number:** 723255 / TW2022



This report is for your exclusive use. Any copying or replication of this report to or for any other person or entity, or use of our name or trademark, is permitted only with our prior written permission. This report sets forth our findings solely with respect to the test samples identified herein. The results set forth in this report are not indicative or representative of the quality or characteristics of the lot from which a test sample was taken or any similar or identical product unless specifically and expressly noted. Our report includes all of the tests requested by you and the results thereof based upon the information that you provided to us. You have 60 days from date of issuance of this report to notify us of any material error or omission caused by our negligence, provided, however, that such notice shall be in writing and shall specifically address the issue you wish to raise. A failure to raise such issue within the prescribed time shall constitute your unqualified acceptance of the completeness of this report, the tests conducted and the correctness of the report contents. Unless specific mention, the uncertainty of measurement has been explicitly taken into account to declare the compliance or non-compliance to the specification. This report should not be used by the client to claim any endorsement by TAF.

Table of Contents

Release Control Record	4
1 Certificate of Conformity	5
2 Summary of Test Results	6
2.1 Measurement Uncertainty	6
2.2 Modification Record	6
3 General Information	7
3.1 General Description of EUT	7
3.2 Description of Test Modes	9
3.2.1 Test Mode Applicability and Tested Channel Detail	10
3.3 Duty Cycle of Test Signal	12
3.4 Description of Support Units	13
3.4.1 Configuration of System under Test	14
3.5 General Description of Applied Standard and references.....	15
4 Test Types and Results	16
4.1 Radiated Emission and Bandedge Measurement.....	16
4.1.1 Limits of Radiated Emission and Bandedge Measurement	16
4.1.2 Test Instruments	17
4.1.3 Test Procedure	19
4.1.4 Deviation from Test Standard	20
4.1.5 Test Setup.....	20
4.1.6 EUT Operating Condition	21
4.1.7 Test Results	22
4.2 Conducted Emission Measurement	42
4.2.1 Limits of Conducted Emission Measurement	42
4.2.2 Test Instruments	42
4.2.3 Test Procedure	43
4.2.4 Deviation from Test Standard	43
4.2.5 Test Setup.....	43
4.2.6 EUT Operating Condition	43
4.2.7 Test Results	44
4.3 Transmit Power Measurement	46
4.3.1 Limits of Transmit Power Measurement	46
4.3.2 Test Setup.....	46
4.3.3 Test Instruments	46
4.3.4 Test Procedure	46
4.3.5 Deviation from Test Standard	46
4.3.6 EUT Operating Condition	46
4.3.7 Test Results	47
4.4 Occupied Bandwidth Measurement	49
4.4.1 Test Setup.....	49
4.4.2 Test Instruments	49
4.4.3 Test Procedure	49
4.4.4 Test Results	50
4.5 Peak Power Spectral Density Measurement	54
4.5.1 Limits of Peak Power Spectral Density Measurement	54
4.5.2 Test Setup.....	54
4.5.3 Test Instruments	54
4.5.4 Test Procedure	54
4.5.5 Deviation from Test Standard	55
4.5.6 EUT Operating Condition	55
4.5.7 Test Results	56
4.6 Frequency Stability Measurement.....	60
4.6.1 Limits of Frequency Stability Measurement	60

4.6.2	Test Setup.....	60
4.6.3	Test Instruments	60
4.6.4	Test Procedure	60
4.6.5	Deviation from Test Standard	60
4.6.6	EUT Operating Condition	60
4.6.7	Test Results	61
4.7	6dB Bandwidth Measurement	62
4.7.1	Limits of 6dB Bandwidth Measurement.....	62
4.7.2	Test Setup.....	62
4.7.3	Test Instruments	62
4.7.4	Test Procedure	62
4.7.5	Deviation from Test Standard	62
4.7.6	EUT Operating Condition	62
4.7.7	Test Results	63
5	Pictures of Test Arrangements.....	65
	Annex A- Radiated Out of Band Emission (OOBE) Measurement (For U-NII-3 band)	66
	Annex B- Band-edge measurement (For U-NII-1 band)	69
	Appendix – Information of the Testing Laboratories	73

Release Control Record

Issue No.	Description	Date Issued
RF200522E11-1	Original release.	July 09, 2020

1 Certificate of Conformity

Product: Starlink Router

Brand: SPACEX

Test Model: UTR-201

Sample Status: ENGINEERING SAMPLE

Applicant: Space Exploration Technologies Corp.

Test Date: June 11 to 30, 2020

Standard: 47 CFR FCC Part 15, Subpart E (Section 15.407)
ANSI C63.10: 2013

The above equipment has been tested by **Bureau Veritas Consumer Products Services (H.K.) Ltd., Taoyuan Branch**, and found compliance with the requirement of the above standards. The test record, data evaluation & Equipment Under Test (EUT) configurations represented herein are true and accurate accounts of the measurements of the sample's EMC characteristics under the conditions specified in this report.

Prepared by : Vivian Huang , **Date:** July 09, 2020
Vivian Huang / Specialist

Approved by : Clark Lin , **Date:** July 09, 2020
Clark Lin / Technical Manager

2 Summary of Test Results

47 CFR FCC Part 15, Subpart E (Section 15.407)			
FCC Clause	Test Item	Result	Remarks
15.407(b)(6)	AC Power Conducted Emissions	Pass	Meet the requirement of limit. Minimum passing margin is -17.93dB at 0.59141MHz.
15.407(b) (1/2/3/4(i/ii)/6)	Radiated Emissions & Band Edge Measurement*	Pass	Meet the requirement of limit. Minimum passing margin is -0.6dB at 5150.00MHz.
15.407(a)(1/2/3)	Max Average Transmit Power	Pass	Meet the requirement of limit.
---	Occupied Bandwidth Measurement	-	Reference only.
15.407(a)(1/2/3)	Peak Power Spectral Density	Pass	Meet the requirement of limit.
15.407(e)	6dB bandwidth	Pass	Meet the requirement of limit. (U-NII-3 Band only)
15.407(g)	Frequency Stability	Pass	Meet the requirement of limit.
15.203	Antenna Requirement	Pass	No antenna connector is used.

Note:

1. For U-NII-3 band compliance with rule part 15.407(b)(4)(i), the OOB test plots were recorded in Annex A.
2. For U-NII-1 band compliance with rule 15.407(b) of the band-edge items, the test plots were recorded in Annex B. Test Procedures refer to report 4.1.3.
3. Determining compliance based on the results of the compliance measurement, not taking into account measurement instrumentation uncertainty.

2.1 Measurement Uncertainty

Where relevant, the following measurement uncertainty levels have been estimated for tests performed on the EUT as specified in CISPR 16-4-2:

Measurement	Frequency	Expanded Uncertainty (k=2) (\pm)
Conducted Emissions at mains ports	150kHz ~ 30MHz	1.9 dB
Radiated Emissions up to 1 GHz	9kHz ~ 30MHz	3.1 dB
	30MHz ~ 1GHz	5.4 dB
Radiated Emissions above 1 GHz	1GHz ~ 18GHz	5.0 dB
	18GHz ~ 40GHz	5.3 dB

2.2 Modification Record

There were no modifications required for compliance.

3 General Information

3.1 General Description of EUT

Product	Starlink Router
Brand	SPACEX
Test Model	UTR-201
Status of EUT	ENGINEERING SAMPLE
Power Supply Rating	56Vdc from PoE adapter
Modulation Type	CCK, DQPSK, DBPSK for DSSS 64QAM, 16QAM, QPSK, BPSK for OFDM 256QAM for OFDM in 11ac mode and VHT20/40 in 2.4GHz
Modulation Technology	DSSS, OFDM
Transfer Rate	802.11b: up to 11 Mbps 802.11a/g: up to 54 Mbps 802.11n: up to 300 Mbps 802.11ac: up to 866.7 Mbps
Operating Frequency	2.4GHz: 2.412GHz ~ 2.462GHz 5GHz: 5.18 ~ 5.24GHz, 5.745 ~ 5.825GHz
Number of Channel	2.4GHz: 802.11b, 802.11g, 802.11n (HT20), VHT20: 11 802.11n (HT40), VHT40: 7 5GHz: 802.11a, 802.11n (HT20), 802.11ac (VHT20): 9 802.11n (HT40), 802.11ac (VHT40): 4 802.11ac (VHT80): 2
Output Power	CDD Mode: 2.412 ~ 2.462 GHz: 990.564 mW 5.18 ~ 5.24 GHz: 781.933 mW 5.745 ~ 5.825 GHz: 775.408 mW Beamforming Mode: 2.412 ~ 2.462 GHz: 757.979 mW 5.18 ~ 5.24 GHz: 781.933 mW 5.745 ~ 5.825 GHz: 775.408 mW
Antenna Type	Refer to Note
Antenna Connector	Refer to Note
Accessory Device	PoE adapter x 1
Data Cable Supplied	RJ45 cable x1 (shielded, 210cm)

Note:

1. The EUT has two radios as following table:

Radio 1	Radio 2
WLAN 2.4GHz	WLAN 5GHz

2. Simultaneously transmission condition.

Condition	Technology	
1	WLAN (2.4GHz)	WLAN (5GHz)

Note: The emission of the simultaneous operation has been evaluated and no non-compliance was found.

3. The EUT must be supplied with a PoE adapter as following table:

No.	Brand	Model No.	Spec.
1	Acbel	UTP-201A	AC Input: 100-240Vac, 2.5A, 50-60Hz DC Output: 56V, 0.3A

4. The antennas provided to the EUT, please refer to the following table:

Antenna NO.	Antenna Net Gain(dBi)	Frequency range	Antenna Type	Connector Type	Cable Length (mm)
1	1.4	2.4~2.4835GHz	PCB	None	NA
	2.3	5.15~5.85GHz			
2	2.3	2.4~2.4835GHz	PCB	None	NA
	3.6	5.15~5.85GHz			

5. The EUT incorporates a MIMO function:

2.4GHz Band		
MODULATION MODE	TX & RX CONFIGURATION	
802.11b	2TX	2RX
802.11g	2TX	2RX
802.11n (HT20)	2TX	2RX
802.11n (HT40)	2TX	2RX
VHT20	2TX	2RX
VHT40	2TX	2RX
5GHz Band		
MODULATION MODE	TX & RX CONFIGURATION	
802.11a	2TX	2RX
802.11n (HT20)	2TX	2RX
802.11n (HT40)	2TX	2RX
802.11ac (VHT20)	2TX	2RX
802.11ac (VHT40)	2TX	2RX
802.11ac (VHT80)	2TX	2RX

Note:

- All of modulation mode support beamforming function except 802.11a/b/g modulation mode.
- The EUT support Beamforming and CDD mode, therefore both mode were investigated and the worst case scenario was identified. The worst case data were presented in test report.
- The modulation and bandwidth are similar for 802.11n mode for 20MHz (40MHz), 802.11ac mode for 20MHz (40MHz, 80MHz), therefore the manufacturer will control the power for 802.11n mode power as same as 802.11ac mode and investigated worst case to representative mode in test report. (Final test mode refer to section 3.2.1)

6. The above EUT information is declared by manufacturer and for more detailed features description, please refers to the manufacturer's specifications or user's manual.

7. The above Antenna information is declared by manufacturer and for more detailed features description, please refer to the manufacturer's specifications, the laboratory shall not be held responsible.

3.2 Description of Test Modes

FOR 5180 ~ 5240MHz

4 channels are provided for 802.11a, 802.11n (HT20), 802.11ac (VHT20):

Channel	Frequency	Channel	Frequency
36	5180 MHz	44	5220 MHz
40	5200 MHz	48	5240 MHz

2 channels are provided for 802.11n (HT40), 802.11ac (VHT40):

Channel	Frequency	Channel	Frequency
38	5190 MHz	46	5230 MHz

1 channel is provided for 802.11ac (VHT80):

Channel	Frequency
42	5210 MHz

FOR 5745 ~ 5825MHz:

5 channels are provided for 802.11a, 802.11n (HT20), 802.11ac (VHT20):

Channel	Frequency	Channel	Frequency
149	5745 MHz	161	5805 MHz
153	5765 MHz	165	5825 MHz
157	5785 MHz		

2 channels are provided for 802.11n (HT40), 802.11ac (VHT40):

Channel	Frequency	Channel	Frequency
151	5755 MHz	159	5795 MHz

1 channel is provided for 802.11ac (VHT80):

Channel	Frequency
155	5775 MHz

3.2.1 Test Mode Applicability and Tested Channel Detail

EUT Configure Mode	Applicable To				Description
	RE≥1G	RE<1G	PLC	APCM	
-	√	√	√	√	-

Where **RE≥1G**: Radiated Emission above 1GHz **RE<1G**: Radiated Emission below 1GHz
PLC: Power Line Conducted Emission **APCM**: Antenna Port Conducted Measurement

Radiated Emission Test (Above 1GHz):

- Pre-Scan has been conducted to determine the worst-case mode from all possible combinations between available modulations, data rates and antenna ports (if EUT with antenna diversity architecture).
- Following channel(s) was (were) selected for the final test as listed below.

CDD Mode						
Mode	FREQ. Band (MHz)	Available Channel	Tested Channel	Modulation Technology	Modulation Type	Data Rate (Mbps)
802.11a	5180-5240	36 to 48	36, 40, 48	OFDM	BPSK	6
802.11ac (VHT20)		36 to 48	36, 40, 48	OFDM	BPSK	6.5
802.11ac (VHT40)		38 to 46	38, 46	OFDM	BPSK	13.5
802.11ac (VHT80)		42	42	OFDM	BPSK	29.3
802.11a	5745-5825	149 to 165	149, 157, 165	OFDM	BPSK	6
802.11ac (VHT20)		149 to 165	149, 157, 165	OFDM	BPSK	6.5
802.11ac (VHT40)		151 to 159	151, 159	OFDM	BPSK	13.5
802.11ac (VHT80)		155	155	OFDM	BPSK	29.3

Radiated Emission Test (Below 1GHz):

- Pre-Scan has been conducted to determine the worst-case mode from all possible combinations between available modulations, data rates and antenna ports (if EUT with antenna diversity architecture).
- Following channel(s) was (were) selected for the final test as listed below.

CDD Mode						
Mode	FREQ. Band (MHz)	Available Channel	Tested Channel	Modulation Technology	Modulation Type	Data Rate (Mbps)
802.11ac (VHT40)	5180-5240 5745-5825	38 to 46 151 to 159	46	OFDM	BPSK	13.5

Power Line Conducted Emission Test:

- Pre-Scan has been conducted to determine the worst-case mode from all possible combinations between available modulations, data rates and antenna ports (if EUT with antenna diversity architecture).
- Following channel(s) was (were) selected for the final test as listed below.

CDD Mode						
Mode	FREQ. Band (MHz)	Available Channel	Tested Channel	Modulation Technology	Modulation Type	Data Rate (Mbps)
802.11ac (VHT40)	5180-5240 5745-5825	38 to 46 151 to 159	46	OFDM	BPSK	13.5

Antenna Port Conducted Measurement:

- This item includes all test value of each mode, but only includes spectrum plot of worst value of each mode.
- Pre-Scan has been conducted to determine the worst-case mode from all possible combinations between available modulations, data rates and antenna ports (if EUT with antenna diversity architecture).
- Following channel(s) was (were) selected for the final test as listed below.

CDD Mode						
Mode	FREQ. Band (MHz)	Available Channel	Tested Channel	Modulation Technology	Modulation Type	Data Rate (Mbps)
802.11a	5180-5240	36 to 48	36, 40, 48	OFDM	BPSK	6
802.11ac (VHT20)		36 to 48	36, 40, 48	OFDM	BPSK	6.5
802.11ac (VHT40)		38 to 46	38, 46	OFDM	BPSK	13.5
802.11ac (VHT80)		42	42	OFDM	BPSK	29.3
802.11a	5745-5825	149 to 165	149, 157, 165	OFDM	BPSK	6
802.11ac (VHT20)		149 to 165	149, 157, 165	OFDM	BPSK	6.5
802.11ac (VHT40)		151 to 159	151, 159	OFDM	BPSK	13.5
802.11ac (VHT80)		155	155	OFDM	BPSK	29.3
Beamforming Mode (output power only)						
Mode	FREQ. Band (MHz)	Available Channel	Tested Channel	Modulation Technology	Modulation Type	Data Rate (Mbps)
802.11ac (VHT20)	5180-5240	36 to 48	36, 40, 48	OFDM	BPSK	6.5
802.11ac (VHT40)		38 to 46	38, 46	OFDM	BPSK	13.5
802.11ac (VHT80)		42	42	OFDM	BPSK	29.3
802.11ac (VHT20)	5745-5825	149 to 165	149, 157, 165	OFDM	BPSK	6.5
802.11ac (VHT40)		151 to 159	151, 159	OFDM	BPSK	13.5
802.11ac (VHT80)		155	155	OFDM	BPSK	29.3

Test Condition:

Applicable To	Environmental Conditions	Input Power	Tested By
RE \geq 1G	24deg. C, 68%RH	120Vac, 60Hz	Nick Lo
RE $<$ 1G	23deg. C, 67%RH	120Vac, 60Hz	Tom Yang
PLC	25deg. C, 68%RH	120Vac, 60Hz	Nick Lo
APCM	25deg. C, 60%RH	120Vac, 60Hz	Jyunchun Lin

3.3 Duty Cycle of Test Signal

If duty cycle of test signal is $\geq 98\%$, duty factor is not required.
 If duty cycle of test signal is $< 98\%$, duty factor shall be considered.

802.11a: Duty cycle = $2.024 \text{ ms} / 2.124 \text{ ms} = 0.953$, Duty factor = $10 * \log(1/\text{Duty cycle}) = 0.21 \text{ dB}$

802.11ac (VHT20): Duty cycle = $4.968 \text{ ms} / 5.07 \text{ ms} = 0.98$

802.11ac (VHT40): Duty cycle = $2.412 \text{ ms} / 2.504 \text{ ms} = 0.963$, Duty factor = $10 * \log(1/\text{Duty cycle}) = 0.16 \text{ dB}$

802.11ac (VHT80): Duty cycle = $1.133 \text{ ms} / 1.214 \text{ ms} = 0.933$, Duty factor = $10 * \log(1/\text{Duty cycle}) = 0.30 \text{ dB}$

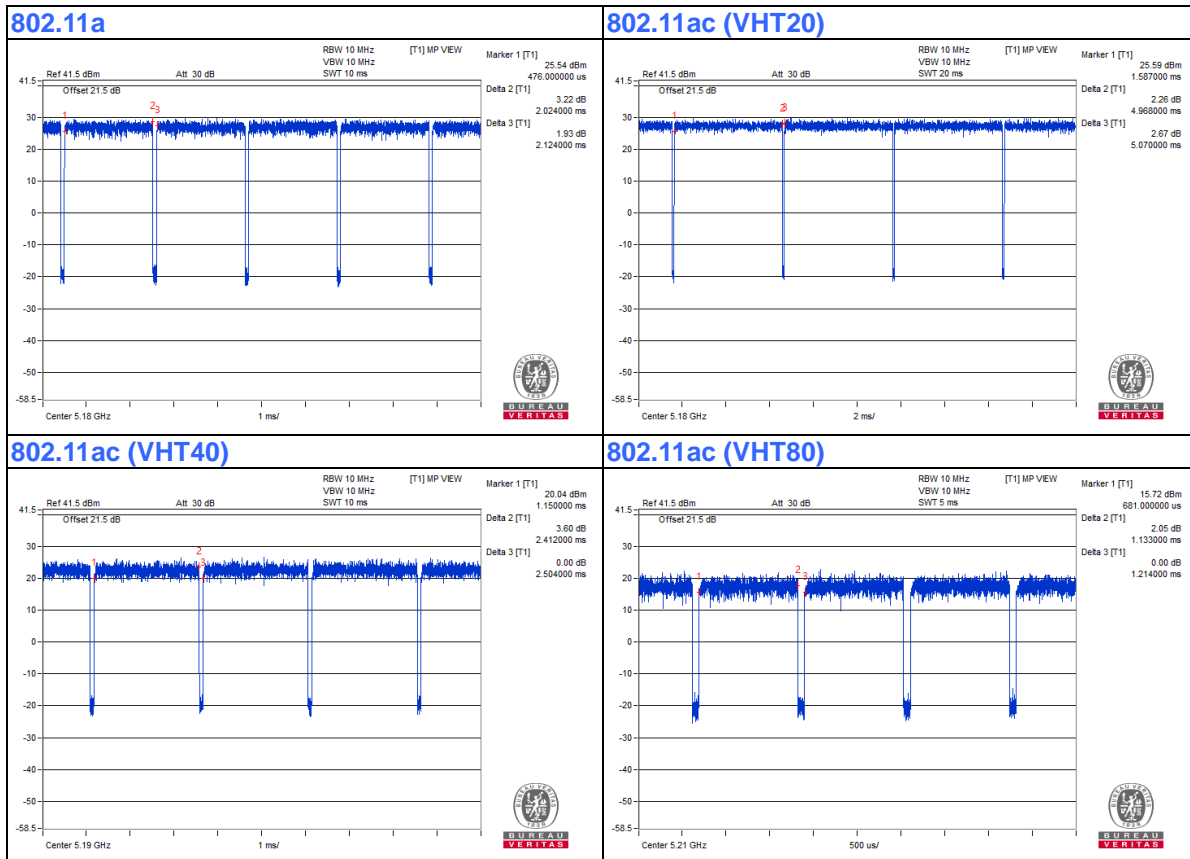

3.4 Description of Support Units

The EUT has been tested as an independent unit together with other necessary accessories or support units. The following support units or accessories were used to form a representative test configuration during the tests.

ID	Product	Brand	Model No.	Serial No.	FCC ID	Remarks
A.	Laptop	DELL	E5430	4YV4VY1	FCC DoC	Provided by Lab
B.	Laptop	DELL	E5430	HYV4VY1	FCC DoC	Provided by Lab

Note:

1. All power cords of the above support units are non-shielded (1.8m).

ID	Descriptions	Qty.	Length (m)	Shielding (Yes/No)	Cores (Qty.)	Remarks
1.	RJ-45 Cable	1	10	Yes	0	Provided by Lab
2.	RJ-45 Cable	1	2	Yes	0	Supplied by client
3.	RJ-45 Cable	1	10	Yes	0	Provided by Lab

3.4.1 Configuration of System under Test

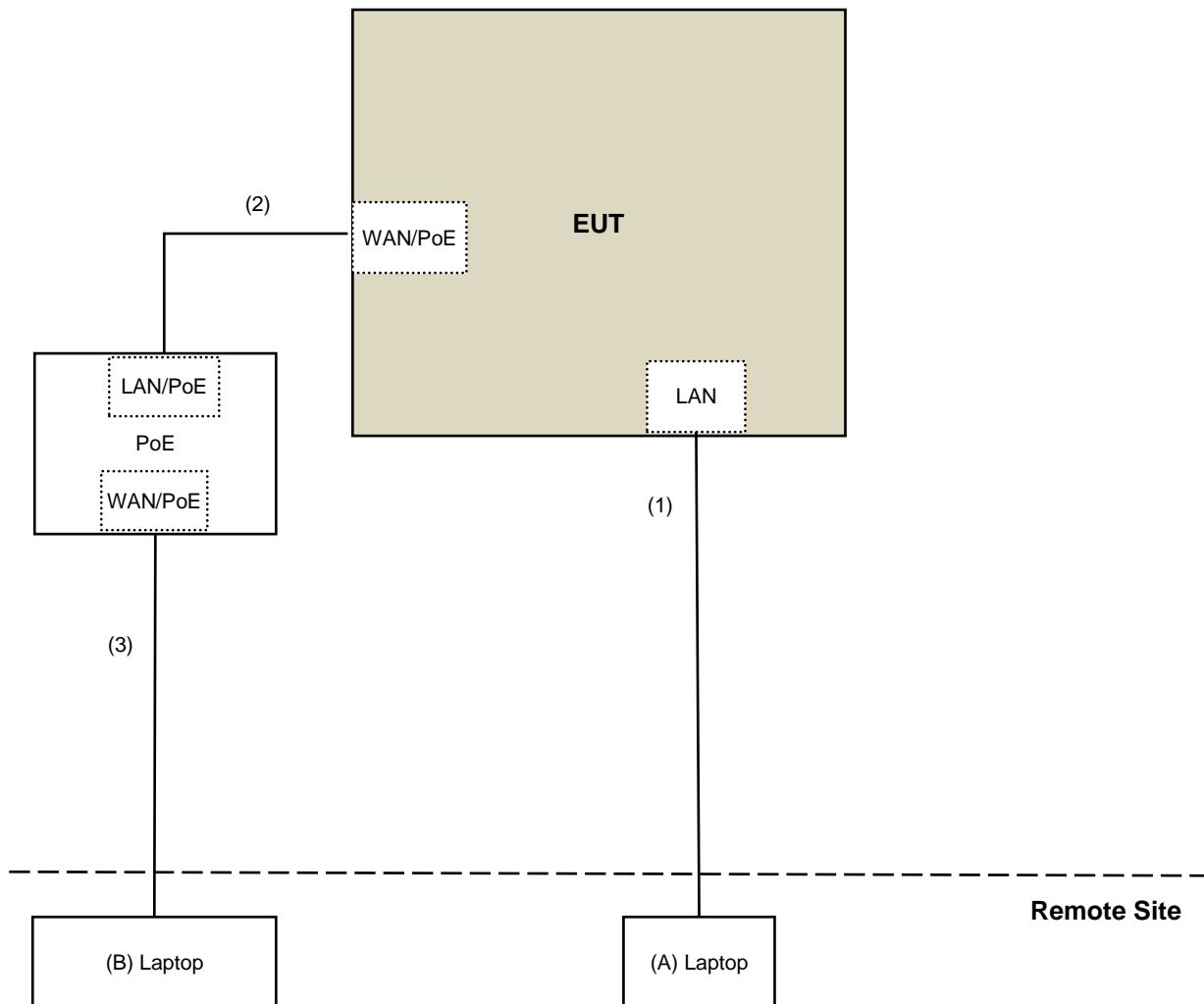

3.5 General Description of Applied Standard and references

The EUT is a RF Product. According to the specifications of the manufacturer, it must comply with the requirements of the following standards and references:

Test Standard:

FCC Part 15, Subpart E (15.407)
ANSI C63.10-2013

All test items have been performed and recorded as per the above standards.

References Test Guidance:

KDB 789033 D02 General UNII Test Procedure New Rules v02r01
KDB 662911 D01 Multiple Transmitter Output v02r01

All test items have been performed as a reference to the above KDB test guidance.

4 Test Types and Results

4.1 Radiated Emission and Bandedge Measurement

4.1.1 Limits of Radiated Emission and Bandedge Measurement

Radiated emissions which fall in the restricted bands must comply with the radiated emission limits specified as below table.

Frequencies (MHz)	Field Strength (microvolts/meter)	Measurement Distance (meters)
0.009 ~ 0.490	2400/F(kHz)	300
0.490 ~ 1.705	24000/F(kHz)	30
1.705 ~ 30.0	30	30
30 ~ 88	100	3
88 ~ 216	150	3
216 ~ 960	200	3
Above 960	500	3

NOTE:

1. The lower limit shall apply at the transition frequencies.
2. Emission level (dBuV/m) = 20 log Emission level (uV/m).
3. For frequencies above 1000MHz, the field strength limits are based on average detector, however, the peak field strength of any emission shall not exceed the maximum permitted average limits, specified above by more than 20dB under any condition of modulation.

Limits of unwanted emission out of the restricted bands

Applicable To		Limit	
789033 D02 General UNII Test Procedure New Rules v02r01		Field Strength at 3m	
		PK:74 (dBuV/m)	AV:54 (dBuV/m)
Frequency Band	Applicable To	EIRP Limit	Equivalent Field Strength at 3m
5150~5250 MHz	15.407(b)(1)	PK:-27 (dBm/MHz)	PK:68.2(dBuV/m)
5250~5350 MHz	15.407(b)(2)		
5470~5725 MHz	15.407(b)(3)		
5725~5850 MHz	15.407(b)(4)(i)	PK:-27 (dBm/MHz) ^{*1} PK:10 (dBm/MHz) ^{*2} PK:15.6 (dBm/MHz) ^{*3} PK:27 (dBm/MHz) ^{*4}	PK: 68.2(dBuV/m) ^{*1} PK:105.2 (dBuV/m) ^{*2} PK: 110.8(dBuV/m) ^{*3} PK:122.2 (dBuV/m) ^{*4}
^{*1} beyond 75 MHz or more above of the band edge.		^{*2} below the band edge increasing linearly to 10 dBm/MHz at 25 MHz above.	
^{*3} below the band edge increasing linearly to a level of 15.6 dBm/MHz at 5 MHz above.		^{*4} from 5 MHz above or below the band edge increasing linearly to a level of 27 dBm/MHz at the band edge.	

Note:

The following formula is used to convert the equipment isotropic radiated power (eirp) to field strength:

$$E = \frac{1000000\sqrt{30P}}{3} \mu\text{V/m, where P is the eirp (Watts).}$$

4.1.2 Test Instruments

For Radiated Emission & Bandedge & OOB test:

DESCRIPTION & MANUFACTURER	MODEL NO.	SERIAL NO.	CALIBRATED DATE	CALIBRATED UNTIL
Test Receiver Keysight	N9038A	MY54450088	July 03, 2019	July 02, 2020
Pre-Amplifier EMCI	EMC001340	980142	May 25, 2020	May 24, 2021
Loop Antenna Electro-Metrics	EM-6879	264	Feb. 18, 2020	Feb. 17, 2021
RF Cable	NA	LOOPCAB-001	Jan. 08, 2020	Jan. 07, 2021
RF Cable	NA	LOOPCAB-002	Jan. 08, 2020	Jan. 07, 2021
Pre-Amplifier Mini-Circuits	ZFL-1000VH2B	AMP-ZFL-05	Apr. 28, 2020	Apr. 27, 2021
Trilog Broadband Antenna SCHWARZBECK	VULB 9168	9168-361	Nov. 11, 2019	Nov. 10, 2020
RF Cable	8D	966-3-1	Mar. 17, 2020	Mar. 16, 2021
RF Cable	8D	966-3-2	Mar. 17, 2020	Mar. 16, 2021
RF Cable	8D	966-3-3	Mar. 17, 2020	Mar. 16, 2021
Fixed attenuator Mini-Circuits	UNAT-5+	PAD-3m-3-01	Sep. 26, 2019	Sep. 25, 2020
Horn_Antenna SCHWARZBECK	BBHA9120-D	9120D-406	Nov. 24, 2019	Nov. 23, 2020
Pre-Amplifier EMCI	EMC12630SE	980384	Jan. 15, 2020	Jan. 14, 2021
RF Cable	EMC104-SM-SM-1200	160922	Jan. 15, 2020	Jan. 14, 2021
RF Cable	EMC104-SM-SM-2000	180601	June 09, 2020	June 08, 2021
RF Cable	EMC104-SM-SM-6000	180602	June 09, 2020	June 08, 2021
Spectrum Analyzer Keysight	N9030A	MY54490679	July 17, 2019	July 16, 2020
Pre-Amplifier EMCI	EMC184045SE	980387	Jan. 15, 2020	Jan. 14, 2021
Horn_Antenna SCHWARZBECK	BBHA 9170	BBHA9170519	Nov. 24, 2019	Nov. 23, 2020
RF Cable	EMC102-KM-KM-1200	160924	Jan. 15, 2020	Jan. 14, 2021
RF Cable	EMC-KM-KM-4000	200214	Mar. 11, 2020	Mar. 10, 2021
Software	ADT_Radiated_V8.7.08	NA	NA	NA
Antenna Tower & Turn Table Max-Full	MF-7802	MF780208406	NA	NA
Boresight Antenna Fixture	FBA-01	FBA-SIP01	NA	NA

Note:

1. The calibration interval of the above test instruments is 12 months and the calibrations are traceable to NML/ROC and NIST/USA.
2. The test was performed in 966 Chamber No. 3.
3. Tested Date: June 11 to 25, 2020

For other test:

DESCRIPTION & MANUFACTURER	MODEL NO.	SERIAL NO.	CALIBRATED DATE	CALIBRATED UNTIL
Spectrum Analyzer R&S	FSV40	100964	May 29, 2020	May 28, 2021
Power meter Anritsu	ML2495A	1529002	July 26, 2019	July 25, 2020
Power sensor Anritsu	MA2411B	1339443	July 26, 2019	July 25, 2020
Fixed Attenuator Mini-Circuits	MDCS18N-10	MDCS18N-10-01	Apr. 14, 2020	Apr. 13, 2021
AC Power Source Extech Electronics	6205	1440452	NA	NA
Temperature & Humidity Chamber Giant Force	GTH-150-40-SP-AR	MAA0812-008	Jan. 16, 2020	Jan. 15, 2021
Voltage Meter FLUKE	179	89610322	Sep. 25, 2019	Sep. 24, 2020
Software	ADT_RF Test Software V6.6.5.4	NA	NA	NA

- NOTE:**
1. The test was performed in Oven room 2.
 2. The calibration interval of the above test instruments is 12 months and the calibrations are traceable to NML/ROC and NIST/USA.
 3. Tested Date: June 30, 2020

4.1.3 Test Procedure

For Radiated emission below 30MHz

- a. The EUT was placed on the top of a rotating table 0.8 meters above the ground at a 3 meter chamber room. The table was rotated 360 degrees to determine the position of the highest radiation.
- b. The EUT was set 3 meters away from the interference-receiving antenna, which was mounted on the top of a variable-height antenna tower.
- c. Parallel, perpendicular, and ground-parallel orientations of the antenna are set to make the measurement.
- d. For each suspected emission, the EUT was arranged to its worst case and the rotatable table was turned from 0 degrees to 360 degrees to find the maximum reading.
- e. The test-receiver system was set to Quasi-Peak Detect Function and Specified Bandwidth with Maximum Hold Mode.

Note:

1. The resolution bandwidth and video bandwidth of test receiver/spectrum analyzer is 9kHz at frequency below 30MHz.

For Radiated emission above 30MHz

- a. The EUT was placed on the top of a rotating table 0.8 meters (for 30MHz ~ 1GHz) / 1.5 meters (for above 1GHz) above the ground at 3 meter chamber room for test. The table was rotated 360 degrees to determine the position of the highest radiation.
- b. The EUT was set 3 meters away from the interference-receiving antenna, which was mounted on the top of a variable-height antenna tower.
- c. The height of antenna is varied from one meter to four meters above the ground to determine the maximum value of the field strength. Both horizontal and vertical polarizations of the antenna are set to make the measurement.
- d. For each suspected emission, the EUT was arranged to its worst case and then the antenna was tuned to heights from 1 meter to 4 meters and the rotatable table was turned from 0 degrees to 360 degrees to find the maximum reading.
- e. The test-receiver system was set to quasi-peak detect function and specified bandwidth with maximum hold mode when the test frequency is below 1 GHz.
- f. The test-receiver system was set to peak and average detects function and specified bandwidth with maximum hold mode when the test frequency is above 1 GHz. If the peak reading value also meets average limit, measurement with the average detector is unnecessary.

Note:

1. The resolution bandwidth and video bandwidth of test receiver/spectrum analyzer is 120kHz for Quasi-peak detection (QP) at frequency below 1GHz.
2. The resolution bandwidth of test receiver/spectrum analyzer is 1 MHz and the video bandwidth is 3 MHz for Peak detection (PK) at frequency above 1GHz.
3. The resolution bandwidth of test receiver/spectrum analyzer is 1MHz and the video bandwidth is $\geq 1/T$ (Duty cycle $< 98\%$) or 10Hz (Duty cycle $\geq 98\%$) for Average detection (AV) at frequency above 1GHz.
4. All modes of operation were investigated and the worst-case emissions are reported.

4.1.4 Deviation from Test Standard

No deviation.

4.1.5 Test Setup

For Radiated emission below 30MHz

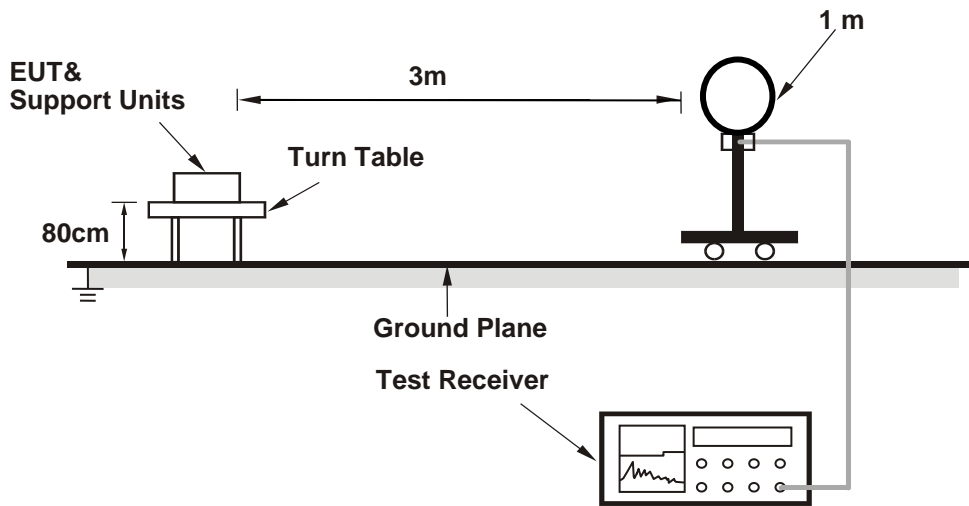

For Radiated emission 30MHz to 1GHz

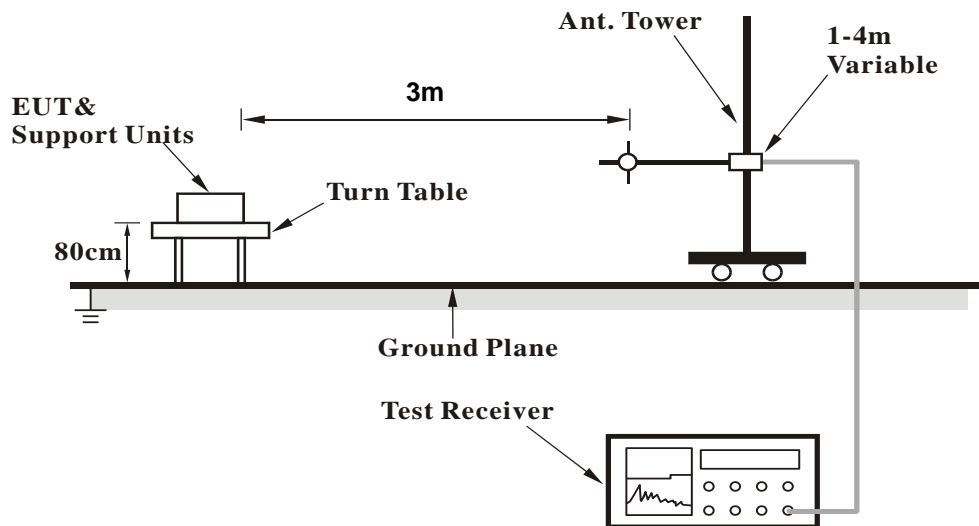

For Radiated emission above 1GHz

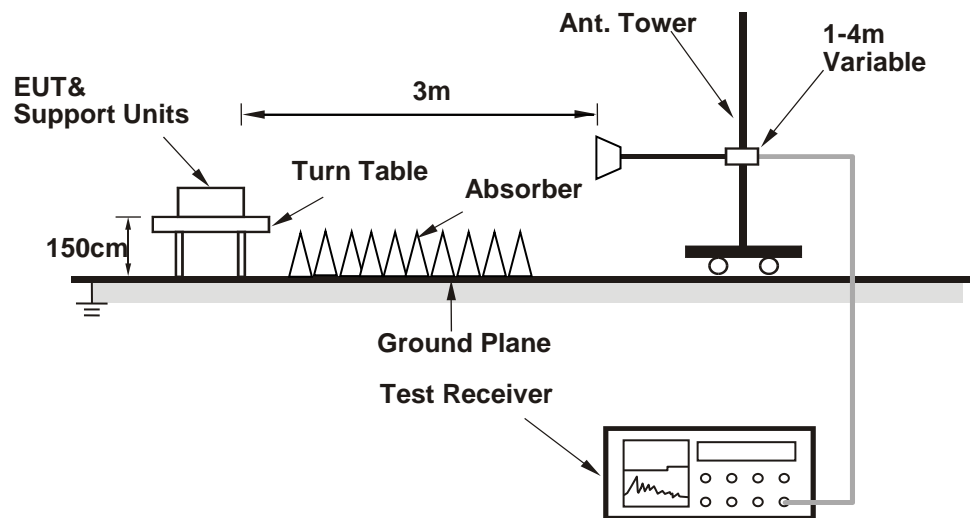

For the actual test configuration, please refer to the attached file (Test Setup Photo).

4.1.6 EUT Operating Condition

- a. Connected the EUT with the Laptop which is placed on remote site.
- b. Controlling software (QDART 4.8.00037) has been activated to set the EUT under transmission condition continuously at specific channel frequency.

4.1.7 Test Results

Above 1GHz Data:

802.11a

Channel	TX Channel 36	Detector Function	Peak (PK)
Frequency Range	1GHz ~ 40GHz		Average (AV)

Antenna Polarity & Test Distance : Horizontal at 3 m

No	Frequency (MHz)	Emission Level (dBuV/m)	Limit (dBuV/m)	Margin (dB)	Antenna Height (m)	Table Angle (Degree)	Raw Value (dBuV)	Correction Factor (dB/m)
1	5150.00	63.6 PK	74.0	-10.4	1.81 H	302	59.9	3.7
2	5150.00	53.1 AV	54.0	-0.9	1.81 H	302	49.4	3.7
3	*5180.00	116.8 PK			1.81 H	302	113.2	3.6
4	*5180.00	106.8 AV			1.81 H	302	103.2	3.6
5	#10360.00	50.4 PK	68.2	-17.8	1.55 H	37	37.7	12.7
6	15540.00	46.1 PK	74.0	-27.9	1.55 H	32	32.9	13.2
7	15540.00	38.0 AV	54.0	-16.0	1.55 H	32	24.8	13.2

Antenna Polarity & Test Distance : Vertical at 3 m

No	Frequency (MHz)	Emission Level (dBuV/m)	Limit (dBuV/m)	Margin (dB)	Antenna Height (m)	Table Angle (Degree)	Raw Value (dBuV)	Correction Factor (dB/m)
1	5150.00	62.5 PK	74.0	-11.5	1.50 V	0	58.8	3.7
2	5150.00	52.0 AV	54.0	-2.0	1.50 V	0	48.3	3.7
3	*5180.00	113.3 PK			1.50 V	0	109.7	3.6
4	*5180.00	105.1 AV			1.50 V	0	101.5	3.6
5	#10360.00	49.3 PK	68.2	-18.9	1.54 V	17	36.6	12.7
6	15540.00	44.2 PK	74.0	-29.8	1.45 V	49	31.0	13.2
7	15540.00	34.0 AV	54.0	-20.0	1.45 V	49	20.8	13.2

Remarks:

1. Emission Level(dBuV/m) = Raw Value(dBuV) + Correction Factor(dB/m)
2. Correction Factor(dB/m) = Antenna Factor(dB/m) + Cable Factor(dB) – Pre-Amplifier Factor(dB)
3. Margin value = Emission Level – Limit value
4. The other emission levels were very low against the limit.
5. " * ": Fundamental frequency.
6. " # ": The radiated frequency is out of the restricted band.

Channel	TX Channel 40	Detector Function	Peak (PK)
Frequency Range	1GHz ~ 40GHz		Average (AV)

Antenna Polarity & Test Distance : Horizontal at 3 m

No	Frequency (MHz)	Emission Level (dBuV/m)	Limit (dBuV/m)	Margin (dB)	Antenna Height (m)	Table Angle (Degree)	Raw Value (dBuV)	Correction Factor (dB/m)
1	*5200.00	119.1 PK			1.83 H	293	115.6	3.5
2	*5200.00	109.1 AV			1.83 H	293	105.6	3.5
3	#10400.00	50.3 PK	68.2	-17.9	1.50 H	21	37.5	12.8
4	15600.00	46.5 PK	74.0	-27.5	1.59 H	38	33.0	13.5
5	15600.00	38.4 AV	54.0	-15.6	1.59 H	38	24.9	13.5

Antenna Polarity & Test Distance : Vertical at 3 m

No	Frequency (MHz)	Emission Level (dBuV/m)	Limit (dBuV/m)	Margin (dB)	Antenna Height (m)	Table Angle (Degree)	Raw Value (dBuV)	Correction Factor (dB/m)
1	*5200.00	118.3 PK			3.41 V	82	114.8	3.5
2	*5200.00	107.5 AV			3.41 V	82	104.0	3.5
3	#10400.00	48.6 PK	68.2	-19.6	1.61 V	10	35.8	12.8
4	15600.00	43.7 PK	74.0	-30.3	1.45 V	18	30.2	13.5
5	15600.00	33.6 AV	54.0	-20.4	1.45 V	18	20.1	13.5

Remarks:

1. Emission Level(dBuV/m) = Raw Value(dBuV) + Correction Factor(dB/m)
2. Correction Factor(dB/m) = Antenna Factor(dB/m) + Cable Factor(dB) – Pre-Amplifier Factor(dB)
3. Margin value = Emission Level – Limit value
4. The other emission levels were very low against the limit.
5. " * ": Fundamental frequency.
6. " # ": The radiated frequency is out of the restricted band.

Channel	TX Channel 48	Detector Function	Peak (PK)
Frequency Range	1GHz ~ 40GHz		Average (AV)

Antenna Polarity & Test Distance : Horizontal at 3 m

No	Frequency (MHz)	Emission Level (dBuV/m)	Limit (dBuV/m)	Margin (dB)	Antenna Height (m)	Table Angle (Degree)	Raw Value (dBuV)	Correction Factor (dB/m)
1	5150.00	51.2 PK	74.0	-22.8	1.89 H	309	47.5	3.7
2	5150.00	41.2 AV	54.0	-12.8	1.89 H	309	37.5	3.7
3	*5240.00	118.6 PK			1.89 H	309	115.1	3.5
4	*5240.00	108.6 AV			1.89 H	309	105.1	3.5
5	5350.00	51.5 PK	74.0	-22.5	1.89 H	309	48.1	3.4
6	5350.00	40.3 AV	54.0	-13.7	1.89 H	309	36.9	3.4
7	#10480.00	49.7 PK	68.2	-18.5	1.49 H	24	36.6	13.1
8	15720.00	45.8 PK	74.0	-28.2	1.65 H	44	32.0	13.8
9	15720.00	37.9 AV	54.0	-16.1	1.65 H	44	24.1	13.8

Antenna Polarity & Test Distance : Vertical at 3 m

No	Frequency (MHz)	Emission Level (dBuV/m)	Limit (dBuV/m)	Margin (dB)	Antenna Height (m)	Table Angle (Degree)	Raw Value (dBuV)	Correction Factor (dB/m)
1	5150.00	50.9 PK	74.0	-23.1	3.39 V	98	47.2	3.7
2	5150.00	39.8 AV	54.0	-14.2	3.39 V	98	36.1	3.7
3	*5240.00	117.8 PK			3.39 V	98	114.3	3.5
4	*5240.00	107.2 AV			3.39 V	98	103.7	3.5
5	5350.00	50.3 PK	74.0	-23.7	3.39 V	98	46.9	3.4
6	5350.00	39.3 AV	54.0	-14.7	3.39 V	98	35.9	3.4
7	#10480.00	49.0 PK	68.2	-19.2	1.45 V	2	35.9	13.1
8	15720.00	44.1 PK	74.0	-29.9	1.53 V	24	30.3	13.8
9	15720.00	34.0 AV	54.0	-20.0	1.53 V	24	20.2	13.8

Remarks:

1. Emission Level(dBuV/m) = Raw Value(dBuV) + Correction Factor(dB/m)
2. Correction Factor(dB/m) = Antenna Factor(dB/m) + Cable Factor(dB) – Pre-Amplifier Factor(dB)
3. Margin value = Emission Level – Limit value
4. The other emission levels were very low against the limit.
5. " * ": Fundamental frequency.
6. " # ": The radiated frequency is out of the restricted band.

Channel	TX Channel 149	Detector Function	Peak (PK)
Frequency Range	1GHz ~ 40GHz		Average (AV)

Antenna Polarity & Test Distance : Horizontal at 3 m

No	Frequency (MHz)	Emission Level (dBuV/m)	Limit (dBuV/m)	Margin (dB)	Antenna Height (m)	Table Angle (Degree)	Raw Value (dBuV)	Correction Factor (dB/m)
1	*5745.00	118.5 PK			1.89 H	295	114.5	4.0
2	*5745.00	108.9 AV			1.89 H	295	104.9	4.0
3	11490.00	52.0 PK	74.0	-22.0	1.55 H	49	38.7	13.3
4	11490.00	47.8 AV	54.0	-6.2	1.55 H	49	34.5	13.3
5	#17235.00	54.6 PK	68.2	-13.6	1.25 H	2	37.0	17.6

Antenna Polarity & Test Distance : Vertical at 3 m

No	Frequency (MHz)	Emission Level (dBuV/m)	Limit (dBuV/m)	Margin (dB)	Antenna Height (m)	Table Angle (Degree)	Raw Value (dBuV)	Correction Factor (dB/m)
1	*5745.00	119.3 PK			3.05 V	353	115.3	4.0
2	*5745.00	109.8 AV			3.05 V	353	105.8	4.0
3	11490.00	46.9 PK	74.0	-27.1	1.56 V	6	33.6	13.3
4	11490.00	44.8 AV	54.0	-9.2	1.56 V	6	31.5	13.3
5	#17235.00	47.4 PK	68.2	-20.8	1.46 V	34	29.8	17.6

Remarks:

1. Emission Level(dBuV/m) = Raw Value(dBuV) + Correction Factor(dB/m)
2. Correction Factor(dB/m) = Antenna Factor(dB/m) + Cable Factor(dB) – Pre-Amplifier Factor(dB)
3. Margin value = Emission Level – Limit value
4. The other emission levels were very low against the limit.
5. " * ": Fundamental frequency.
6. " # ": The radiated frequency is out of the restricted band.

Channel	TX Channel 157	Detector Function	Peak (PK)
Frequency Range	1GHz ~ 40GHz		Average (AV)

Antenna Polarity & Test Distance : Horizontal at 3 m

No	Frequency (MHz)	Emission Level (dBuV/m)	Limit (dBuV/m)	Margin (dB)	Antenna Height (m)	Table Angle (Degree)	Raw Value (dBuV)	Correction Factor (dB/m)
1	*5785.00	118.3 PK			1.89 H	296	114.2	4.1
2	*5785.00	108.6 AV			1.89 H	296	104.5	4.1
3	11570.00	51.6 PK	74.0	-22.4	1.50 H	45	38.4	13.2
4	11570.00	47.5 AV	54.0	-6.5	1.50 H	45	34.3	13.2
5	#17355.00	55.0 PK	68.2	-13.2	1.28 H	5	37.4	17.6

Antenna Polarity & Test Distance : Vertical at 3 m

No	Frequency (MHz)	Emission Level (dBuV/m)	Limit (dBuV/m)	Margin (dB)	Antenna Height (m)	Table Angle (Degree)	Raw Value (dBuV)	Correction Factor (dB/m)
1	*5785.00	119.2 PK			3.04 V	352	115.1	4.1
2	*5785.00	110.2 AV			3.04 V	352	106.1	4.1
3	11570.00	47.2 PK	74.0	-26.8	1.50 V	0	34.0	13.2
4	11570.00	44.8 AV	54.0	-9.2	1.50 V	0	31.6	13.2
5	#17355.00	47.8 PK	68.2	-20.4	1.50 V	32	30.2	17.6

Remarks:

1. Emission Level(dBuV/m) = Raw Value(dBuV) + Correction Factor(dB/m)
2. Correction Factor(dB/m) = Antenna Factor(dB/m) + Cable Factor(dB) – Pre-Amplifier Factor(dB)
3. Margin value = Emission Level – Limit value
4. The other emission levels were very low against the limit.
5. " * ": Fundamental frequency.
6. " # ": The radiated frequency is out of the restricted band.

Channel	TX Channel 165	Detector Function	Peak (PK)
Frequency Range	1GHz ~ 40GHz		Average (AV)

Antenna Polarity & Test Distance : Horizontal at 3 m

No	Frequency (MHz)	Emission Level (dBuV/m)	Limit (dBuV/m)	Margin (dB)	Antenna Height (m)	Table Angle (Degree)	Raw Value (dBuV)	Correction Factor (dB/m)
1	*5825.00	118.2 PK			1.88 H	294	113.9	4.3
2	*5825.00	108.5 AV			1.88 H	294	104.2	4.3
3	11650.00	51.1 PK	74.0	-22.9	1.48 H	50	37.8	13.3
4	11650.00	47.1 AV	54.0	-6.9	1.48 H	50	33.8	13.3
5	#17475.00	54.9 PK	68.2	-13.3	1.25 H	6	37.0	17.9

Antenna Polarity & Test Distance : Vertical at 3 m

No	Frequency (MHz)	Emission Level (dBuV/m)	Limit (dBuV/m)	Margin (dB)	Antenna Height (m)	Table Angle (Degree)	Raw Value (dBuV)	Correction Factor (dB/m)
1	*5825.00	119.6 PK			3.05 V	352	115.3	4.3
2	*5825.00	110.5 AV			3.05 V	352	106.2	4.3
3	11650.00	46.7 PK	74.0	-27.3	1.62 V	12	33.4	13.3
4	11650.00	44.4 AV	54.0	-9.6	1.62 V	12	31.1	13.3
5	#17475.00	47.8 PK	68.2	-20.4	1.49 V	29	29.9	17.9

Remarks:

1. Emission Level(dBuV/m) = Raw Value(dBuV) + Correction Factor(dB/m)
2. Correction Factor(dB/m) = Antenna Factor(dB/m) + Cable Factor(dB) – Pre-Amplifier Factor(dB)
3. Margin value = Emission Level – Limit value
4. The other emission levels were very low against the limit.
5. " * ": Fundamental frequency.
6. " # ": The radiated frequency is out of the restricted band.

802.11ac (VHT20)

Channel	TX Channel 36	Detector Function	Peak (PK)
Frequency Range	1GHz ~ 40GHz		Average (AV)

Antenna Polarity & Test Distance : Horizontal at 3 m

No	Frequency (MHz)	Emission Level (dBuV/m)	Limit (dBuV/m)	Margin (dB)	Antenna Height (m)	Table Angle (Degree)	Raw Value (dBuV)	Correction Factor (dB/m)
1	5150.00	64.8 PK	74.0	-9.2	1.70 H	303	61.1	3.7
2	5150.00	53.4 AV	54.0	-0.6	1.70 H	303	49.7	3.7
3	*5180.00	117.9 PK			1.70 H	303	114.3	3.6
4	*5180.00	107.6 AV			1.70 H	303	104.0	3.6
5	#10360.00	50.9 PK	68.2	-17.3	1.52 H	22	38.2	12.7
6	15540.00	46.3 PK	74.0	-27.7	1.56 H	30	33.1	13.2
7	15540.00	38.2 AV	54.0	-15.8	1.56 H	30	25.0	13.2

Antenna Polarity & Test Distance : Vertical at 3 m

No	Frequency (MHz)	Emission Level (dBuV/m)	Limit (dBuV/m)	Margin (dB)	Antenna Height (m)	Table Angle (Degree)	Raw Value (dBuV)	Correction Factor (dB/m)
1	5150.00	63.0 PK	74.0	-11.0	1.50 V	360	59.3	3.7
2	5150.00	48.4 AV	54.0	-5.6	1.50 V	360	44.7	3.7
3	*5180.00	113.3 PK			1.50 V	360	109.7	3.6
4	*5180.00	103.9 AV			1.50 V	360	100.3	3.6
5	#10360.00	49.2 PK	68.2	-19.0	1.49 V	17	36.5	12.7
6	15540.00	43.6 PK	74.0	-30.4	1.47 V	54	30.4	13.2
7	15540.00	33.6 AV	54.0	-20.4	1.47 V	54	20.4	13.2

Remarks:

1. Emission Level(dBuV/m) = Raw Value(dBuV) + Correction Factor(dB/m)
2. Correction Factor(dB/m) = Antenna Factor(dB/m) + Cable Factor(dB) – Pre-Amplifier Factor(dB)
3. Margin value = Emission Level – Limit value
4. The other emission levels were very low against the limit.
5. " * ": Fundamental frequency.
6. " # ": The radiated frequency is out of the restricted band.

Channel	TX Channel 40	Detector Function	Peak (PK)
Frequency Range	1GHz ~ 40GHz		Average (AV)

Antenna Polarity & Test Distance : Horizontal at 3 m

No	Frequency (MHz)	Emission Level (dBuV/m)	Limit (dBuV/m)	Margin (dB)	Antenna Height (m)	Table Angle (Degree)	Raw Value (dBuV)	Correction Factor (dB/m)
1	*5200.00	119.4 PK			1.89 H	285	115.9	3.5
2	*5200.00	108.8 AV			1.89 H	285	105.3	3.5
3	#10400.00	49.9 PK	68.2	-18.3	1.49 H	34	37.1	12.8
4	15600.00	46.5 PK	74.0	-27.5	1.62 H	35	33.0	13.5
5	15600.00	38.6 AV	54.0	-15.4	1.62 H	35	25.1	13.5

Antenna Polarity & Test Distance : Vertical at 3 m

No	Frequency (MHz)	Emission Level (dBuV/m)	Limit (dBuV/m)	Margin (dB)	Antenna Height (m)	Table Angle (Degree)	Raw Value (dBuV)	Correction Factor (dB/m)
1	*5200.00	116.5 PK			3.19 V	89	113.0	3.5
2	*5200.00	107.3 AV			3.19 V	89	103.8	3.5
3	#10400.00	48.7 PK	68.2	-19.5	1.62 V	5	35.9	12.8
4	15600.00	44.0 PK	74.0	-30.0	1.43 V	14	30.5	13.5
5	15600.00	33.7 AV	54.0	-20.3	1.43 V	14	20.2	13.5

Remarks:

1. Emission Level(dBuV/m) = Raw Value(dBuV) + Correction Factor(dB/m)
2. Correction Factor(dB/m) = Antenna Factor(dB/m) + Cable Factor(dB) – Pre-Amplifier Factor(dB)
3. Margin value = Emission Level – Limit value
4. The other emission levels were very low against the limit.
5. " * ": Fundamental frequency.
6. " # ": The radiated frequency is out of the restricted band.

Channel	TX Channel 48	Detector Function	Peak (PK)
Frequency Range	1GHz ~ 40GHz		Average (AV)

Antenna Polarity & Test Distance : Horizontal at 3 m

No	Frequency (MHz)	Emission Level (dBuV/m)	Limit (dBuV/m)	Margin (dB)	Antenna Height (m)	Table Angle (Degree)	Raw Value (dBuV)	Correction Factor (dB/m)
1	5150.00	52.8 PK	74.0	-21.2	1.90 H	286	49.1	3.7
2	5150.00	41.2 AV	54.0	-12.8	1.90 H	286	37.5	3.7
3	*5240.00	119.2 PK			1.90 H	286	115.7	3.5
4	*5240.00	108.8 AV			1.90 H	286	105.3	3.5
5	5350.00	50.0 PK	74.0	-24.0	1.90 H	286	46.6	3.4
6	5350.00	40.2 AV	54.0	-13.8	1.90 H	286	36.8	3.4
7	#10480.00	49.9 PK	68.2	-18.3	1.55 H	25	36.8	13.1
8	15720.00	45.5 PK	74.0	-28.5	1.63 H	55	31.7	13.8
9	15720.00	37.7 AV	54.0	-16.3	1.63 H	55	23.9	13.8

Antenna Polarity & Test Distance : Vertical at 3 m

No	Frequency (MHz)	Emission Level (dBuV/m)	Limit (dBuV/m)	Margin (dB)	Antenna Height (m)	Table Angle (Degree)	Raw Value (dBuV)	Correction Factor (dB/m)
1	5150.00	50.9 PK	74.0	-23.1	3.24 V	98	47.2	3.7
2	5150.00	39.8 AV	54.0	-14.2	3.24 V	98	36.1	3.7
3	*5240.00	116.2 PK			3.24 V	98	112.7	3.5
4	*5240.00	106.9 AV			3.24 V	98	103.4	3.5
5	5350.00	50.8 PK	74.0	-23.2	3.24 V	98	47.4	3.4
6	5350.00	39.6 AV	54.0	-14.4	3.24 V	98	36.2	3.4
7	#10480.00	48.6 PK	68.2	-19.6	1.41 V	7	35.5	13.1
8	15720.00	44.3 PK	74.0	-29.7	1.55 V	25	30.5	13.8
9	15720.00	34.1 AV	54.0	-19.9	1.55 V	25	20.3	13.8

Remarks:

1. Emission Level(dBuV/m) = Raw Value(dBuV) + Correction Factor(dB/m)
2. Correction Factor(dB/m) = Antenna Factor(dB/m) + Cable Factor(dB) – Pre-Amplifier Factor(dB)
3. Margin value = Emission Level – Limit value
4. The other emission levels were very low against the limit.
5. " * ": Fundamental frequency.
6. " # ": The radiated frequency is out of the restricted band.

Channel	TX Channel 149	Detector Function	Peak (PK)
Frequency Range	1GHz ~ 40GHz		Average (AV)

Antenna Polarity & Test Distance : Horizontal at 3 m

No	Frequency (MHz)	Emission Level (dBuV/m)	Limit (dBuV/m)	Margin (dB)	Antenna Height (m)	Table Angle (Degree)	Raw Value (dBuV)	Correction Factor (dB/m)
1	*5745.00	118.8 PK			1.80 H	287	114.8	4.0
2	*5745.00	109.3 AV			1.80 H	287	105.3	4.0
3	11490.00	52.0 PK	74.0	-22.0	1.55 H	57	38.7	13.3
4	11490.00	47.9 AV	54.0	-6.1	1.55 H	57	34.6	13.3
5	#17235.00	54.9 PK	68.2	-13.3	1.29 H	1	37.3	17.6

Antenna Polarity & Test Distance : Vertical at 3 m

No	Frequency (MHz)	Emission Level (dBuV/m)	Limit (dBuV/m)	Margin (dB)	Antenna Height (m)	Table Angle (Degree)	Raw Value (dBuV)	Correction Factor (dB/m)
1	*5745.00	118.6 PK			2.29 V	351	114.6	4.0
2	*5745.00	108.8 AV			2.29 V	351	104.8	4.0
3	11490.00	46.7 PK	74.0	-27.3	1.58 V	7	33.4	13.3
4	11490.00	44.5 AV	54.0	-9.5	1.58 V	7	31.2	13.3
5	#17235.00	47.1 PK	68.2	-21.1	1.51 V	46	29.5	17.6

Remarks:

1. Emission Level(dBuV/m) = Raw Value(dBuV) + Correction Factor(dB/m)
2. Correction Factor(dB/m) = Antenna Factor(dB/m) + Cable Factor(dB) – Pre-Amplifier Factor(dB)
3. Margin value = Emission Level – Limit value
4. The other emission levels were very low against the limit.
5. " * ": Fundamental frequency.
6. " # ": The radiated frequency is out of the restricted band.

Channel	TX Channel 157	Detector Function	Peak (PK)
Frequency Range	1GHz ~ 40GHz		Average (AV)

Antenna Polarity & Test Distance : Horizontal at 3 m

No	Frequency (MHz)	Emission Level (dBuV/m)	Limit (dBuV/m)	Margin (dB)	Antenna Height (m)	Table Angle (Degree)	Raw Value (dBuV)	Correction Factor (dB/m)
1	*5785.00	118.7 PK			1.79 H	292	114.6	4.1
2	*5785.00	108.8 AV			1.79 H	292	104.7	4.1
3	11570.00	51.7 PK	74.0	-22.3	1.55 H	59	38.5	13.2
4	11570.00	47.6 AV	54.0	-6.4	1.55 H	59	34.4	13.2
5	#17355.00	55.1 PK	68.2	-13.1	1.23 H	16	37.5	17.6

Antenna Polarity & Test Distance : Vertical at 3 m

No	Frequency (MHz)	Emission Level (dBuV/m)	Limit (dBuV/m)	Margin (dB)	Antenna Height (m)	Table Angle (Degree)	Raw Value (dBuV)	Correction Factor (dB/m)
1	*5785.00	118.7 PK			2.29 V	352	114.6	4.1
2	*5785.00	109.1 AV			2.29 V	352	105.0	4.1
3	11570.00	46.9 PK	74.0	-27.1	1.52 V	20	33.7	13.2
4	11570.00	44.7 AV	54.0	-9.3	1.52 V	20	31.5	13.2
5	#17355.00	46.9 PK	68.2	-21.3	1.47 V	25	29.3	17.6

Remarks:

1. Emission Level(dBuV/m) = Raw Value(dBuV) + Correction Factor(dB/m)
2. Correction Factor(dB/m) = Antenna Factor(dB/m) + Cable Factor(dB) – Pre-Amplifier Factor(dB)
3. Margin value = Emission Level – Limit value
4. The other emission levels were very low against the limit.
5. " * ": Fundamental frequency.
6. " # ": The radiated frequency is out of the restricted band.

Channel	TX Channel 165	Detector Function	Peak (PK)
Frequency Range	1GHz ~ 40GHz		Average (AV)

Antenna Polarity & Test Distance : Horizontal at 3 m

No	Frequency (MHz)	Emission Level (dBuV/m)	Limit (dBuV/m)	Margin (dB)	Antenna Height (m)	Table Angle (Degree)	Raw Value (dBuV)	Correction Factor (dB/m)
1	*5825.00	118.4 PK			1.50 H	301	114.1	4.3
2	*5825.00	108.5 AV			1.50 H	301	104.2	4.3
3	11650.00	51.7 PK	74.0	-22.3	1.48 H	51	38.4	13.3
4	11650.00	47.4 AV	54.0	-6.6	1.48 H	51	34.1	13.3
5	#17475.00	55.3 PK	68.2	-12.9	1.25 H	4	37.4	17.9

Antenna Polarity & Test Distance : Vertical at 3 m

No	Frequency (MHz)	Emission Level (dBuV/m)	Limit (dBuV/m)	Margin (dB)	Antenna Height (m)	Table Angle (Degree)	Raw Value (dBuV)	Correction Factor (dB/m)
1	*5825.00	118.9 PK			2.28 V	351	114.6	4.3
2	*5825.00	109.3 AV			2.28 V	351	105.0	4.3
3	11650.00	47.1 PK	74.0	-26.9	1.56 V	4	33.8	13.3
4	11650.00	44.9 AV	54.0	-9.1	1.56 V	4	31.6	13.3
5	#17475.00	46.6 PK	68.2	-21.6	1.52 V	35	28.7	17.9

Remarks:

1. Emission Level(dBuV/m) = Raw Value(dBuV) + Correction Factor(dB/m)
2. Correction Factor(dB/m) = Antenna Factor(dB/m) + Cable Factor(dB) – Pre-Amplifier Factor(dB)
3. Margin value = Emission Level – Limit value
4. The other emission levels were very low against the limit.
5. " * ": Fundamental frequency.
6. " # ": The radiated frequency is out of the restricted band.

802.11ac (VHT40)

Channel	TX Channel 38	Detector Function	Peak (PK)
Frequency Range	1GHz ~ 40GHz		Average (AV)

Antenna Polarity & Test Distance : Horizontal at 3 m

No	Frequency (MHz)	Emission Level (dBuV/m)	Limit (dBuV/m)	Margin (dB)	Antenna Height (m)	Table Angle (Degree)	Raw Value (dBuV)	Correction Factor (dB/m)
1	5150.00	65.8 PK	74.0	-8.2	1.82 H	304	62.1	3.7
2	5150.00	52.8 AV	54.0	-1.2	1.82 H	304	49.1	3.7
3	*5190.00	112.8 PK			1.82 H	304	109.2	3.6
4	*5190.00	103.1 AV			1.82 H	304	99.5	3.6
5	#10380.00	48.5 PK	68.2	-19.7	1.49 H	33	35.8	12.7
6	15570.00	45.1 PK	74.0	-28.9	1.59 H	29	31.7	13.4
7	15570.00	37.8 AV	54.0	-16.2	1.59 H	29	24.4	13.4

Antenna Polarity & Test Distance : Vertical at 3 m

No	Frequency (MHz)	Emission Level (dBuV/m)	Limit (dBuV/m)	Margin (dB)	Antenna Height (m)	Table Angle (Degree)	Raw Value (dBuV)	Correction Factor (dB/m)
1	5150.00	65.3 PK	74.0	-8.7	1.50 V	358	61.6	3.7
2	5150.00	49.6 AV	54.0	-4.4	1.50 V	358	45.9	3.7
3	*5190.00	108.3 PK			1.50 V	358	104.7	3.6
4	*5190.00	99.4 AV			1.50 V	358	95.8	3.6
5	#10380.00	48.1 PK	68.2	-20.1	1.44 V	3	35.4	12.7
6	15570.00	44.8 PK	74.0	-29.2	1.58 V	35	31.4	13.4
7	15570.00	33.4 AV	54.0	-20.6	1.58 V	35	20.0	13.4

Remarks:

1. Emission Level(dBuV/m) = Raw Value(dBuV) + Correction Factor(dB/m)
2. Correction Factor(dB/m) = Antenna Factor(dB/m) + Cable Factor(dB) – Pre-Amplifier Factor(dB)
3. Margin value = Emission Level – Limit value
4. The other emission levels were very low against the limit.
5. " * ": Fundamental frequency.
6. " # ": The radiated frequency is out of the restricted band.

Channel	TX Channel 46	Detector Function	Peak (PK)
Frequency Range	1GHz ~ 40GHz		Average (AV)

Antenna Polarity & Test Distance : Horizontal at 3 m

No	Frequency (MHz)	Emission Level (dBuV/m)	Limit (dBuV/m)	Margin (dB)	Antenna Height (m)	Table Angle (Degree)	Raw Value (dBuV)	Correction Factor (dB/m)
1	5150.00	60.2 PK	74.0	-13.8	1.89 H	304	56.5	3.7
2	5150.00	48.2 AV	54.0	-5.8	1.89 H	304	44.5	3.7
3	*5230.00	114.8 PK			1.89 H	304	111.3	3.5
4	*5230.00	105.5 AV			1.89 H	304	102.0	3.5
5	5350.00	54.1 PK	74.0	-19.9	1.89 H	304	50.7	3.4
6	5350.00	42.6 AV	54.0	-11.4	1.89 H	304	39.2	3.4
7	#10460.00	48.3 PK	68.2	-19.9	1.55 H	20	35.3	13.0
8	15690.00	45.1 PK	74.0	-28.9	1.65 H	32	31.2	13.9
9	15690.00	37.9 AV	54.0	-16.1	1.65 H	32	24.0	13.9

Antenna Polarity & Test Distance : Vertical at 3 m

No	Frequency (MHz)	Emission Level (dBuV/m)	Limit (dBuV/m)	Margin (dB)	Antenna Height (m)	Table Angle (Degree)	Raw Value (dBuV)	Correction Factor (dB/m)
1	5150.00	55.8 PK	74.0	-18.2	1.50 V	181	52.1	3.7
2	5150.00	43.7 AV	54.0	-10.3	1.50 V	181	40.0	3.7
3	*5230.00	109.7 PK			1.50 V	181	106.2	3.5
4	*5230.00	102.3 AV			1.50 V	181	98.8	3.5
5	5350.00	52.1 PK	74.0	-21.9	1.50 V	181	48.7	3.4
6	5350.00	40.4 AV	54.0	-13.6	1.50 V	181	37.0	3.4
7	#10460.00	47.9 PK	68.2	-20.3	1.36 V	9	34.9	13.0
8	15690.00	43.7 PK	74.0	-30.3	1.58 V	14	29.8	13.9
9	15690.00	32.6 AV	54.0	-21.4	1.58 V	14	18.7	13.9

Remarks:

1. Emission Level(dBuV/m) = Raw Value(dBuV) + Correction Factor(dB/m)
2. Correction Factor(dB/m) = Antenna Factor(dB/m) + Cable Factor(dB) – Pre-Amplifier Factor(dB)
3. Margin value = Emission Level – Limit value
4. The other emission levels were very low against the limit.
5. " * ": Fundamental frequency.
6. " # ": The radiated frequency is out of the restricted band.

Channel	TX Channel 151	Detector Function	Peak (PK)
Frequency Range	1GHz ~ 40GHz		Average (AV)

Antenna Polarity & Test Distance : Horizontal at 3 m

No	Frequency (MHz)	Emission Level (dBuV/m)	Limit (dBuV/m)	Margin (dB)	Antenna Height (m)	Table Angle (Degree)	Raw Value (dBuV)	Correction Factor (dB/m)
1	*5755.00	115.0 PK			1.84 H	290	111.0	4.0
2	*5755.00	106.9 AV			1.84 H	290	102.9	4.0
3	11510.00	50.6 PK	74.0	-23.4	1.53 H	71	37.3	13.3
4	11510.00	45.9 AV	54.0	-8.1	1.53 H	71	32.6	13.3
5	#17265.00	53.7 PK	68.2	-14.5	1.17 H	4	36.2	17.5

Antenna Polarity & Test Distance : Vertical at 3 m

No	Frequency (MHz)	Emission Level (dBuV/m)	Limit (dBuV/m)	Margin (dB)	Antenna Height (m)	Table Angle (Degree)	Raw Value (dBuV)	Correction Factor (dB/m)
1	*5755.00	115.1 PK			3.24 V	349	111.1	4.0
2	*5755.00	106.3 AV			3.24 V	349	102.3	4.0
3	11510.00	46.7 PK	74.0	-27.3	1.56 V	2	33.4	13.3
4	11510.00	42.5 AV	54.0	-11.5	1.56 V	2	29.2	13.3
5	#17265.00	46.8 PK	68.2	-21.4	1.53 V	30	29.3	17.5

Remarks:

1. Emission Level(dBuV/m) = Raw Value(dBuV) + Correction Factor(dB/m)
2. Correction Factor(dB/m) = Antenna Factor(dB/m) + Cable Factor(dB) – Pre-Amplifier Factor(dB)
3. Margin value = Emission Level – Limit value
4. The other emission levels were very low against the limit.
5. " * ": Fundamental frequency.
6. " # ": The radiated frequency is out of the restricted band.

Channel	TX Channel 159	Detector Function	Peak (PK)
Frequency Range	1GHz ~ 40GHz		Average (AV)

Antenna Polarity & Test Distance : Horizontal at 3 m

No	Frequency (MHz)	Emission Level (dBuV/m)	Limit (dBuV/m)	Margin (dB)	Antenna Height (m)	Table Angle (Degree)	Raw Value (dBuV)	Correction Factor (dB/m)
1	*5795.00	114.7 PK			1.84 H	288	110.5	4.2
2	*5795.00	106.7 AV			1.84 H	288	102.5	4.2
3	11590.00	51.2 PK	74.0	-22.8	1.55 H	60	37.9	13.3
4	11590.00	45.6 AV	54.0	-8.4	1.55 H	60	32.3	13.3
5	#17385.00	53.1 PK	68.2	-15.1	1.12 H	5	35.4	17.7

Antenna Polarity & Test Distance : Vertical at 3 m

No	Frequency (MHz)	Emission Level (dBuV/m)	Limit (dBuV/m)	Margin (dB)	Antenna Height (m)	Table Angle (Degree)	Raw Value (dBuV)	Correction Factor (dB/m)
1	*5795.00	115.6 PK			2.62 V	356	111.4	4.2
2	*5795.00	107.1 AV			2.62 V	356	102.9	4.2
3	11590.00	46.4 PK	74.0	-27.6	1.59 V	4	33.1	13.3
4	11590.00	42.1 AV	54.0	-11.9	1.59 V	4	28.8	13.3
5	#17385.00	46.4 PK	68.2	-21.8	1.52 V	25	28.7	17.7

Remarks:

1. Emission Level(dBuV/m) = Raw Value(dBuV) + Correction Factor(dB/m)
2. Correction Factor(dB/m) = Antenna Factor(dB/m) + Cable Factor(dB) – Pre-Amplifier Factor(dB)
3. Margin value = Emission Level – Limit value
4. The other emission levels were very low against the limit.
5. " * ": Fundamental frequency.
6. " # ": The radiated frequency is out of the restricted band.

802.11ac (VHT80)

Channel	TX Channel 42	Detector Function	Peak (PK)
Frequency Range	1GHz ~ 40GHz		Average (AV)

Antenna Polarity & Test Distance : Horizontal at 3 m								
No	Frequency (MHz)	Emission Level (dBuV/m)	Limit (dBuV/m)	Margin (dB)	Antenna Height (m)	Table Angle (Degree)	Raw Value (dBuV)	Correction Factor (dB/m)
1	5140.22	66.5 PK	74.0	-7.5	1.50 H	305	62.8	3.7
2	5140.22	53.1 AV	54.0	-0.9	1.50 H	305	49.4	3.7
3	*5210.00	107.9 PK			1.50 H	305	104.3	3.6
4	*5210.00	99.4 AV			1.50 H	305	95.8	3.6
5	5350.00	57.4 PK	74.0	-16.6	1.50 H	305	54.0	3.4
6	5350.00	45.9 AV	54.0	-8.1	1.50 H	305	42.5	3.4
7	#10420.00	48.8 PK	68.2	-19.4	1.51 H	31	36.0	12.8
8	15630.00	45.1 PK	74.0	-28.9	1.58 H	44	31.4	13.7
9	15630.00	38.0 AV	54.0	-16.0	1.58 H	44	24.3	13.7

Antenna Polarity & Test Distance : Vertical at 3 m								
No	Frequency (MHz)	Emission Level (dBuV/m)	Limit (dBuV/m)	Margin (dB)	Antenna Height (m)	Table Angle (Degree)	Raw Value (dBuV)	Correction Factor (dB/m)
1	5144.71	66.6 PK	74.0	-7.4	1.50 V	357	62.9	3.7
2	5144.71	49.7 AV	54.0	-4.3	1.50 V	357	46.0	3.7
3	*5210.00	104.3 PK			1.50 V	357	100.7	3.6
4	*5210.00	95.2 AV			1.50 V	357	91.6	3.6
5	5350.00	54.5 PK	74.0	-19.5	1.50 V	357	51.1	3.4
6	5350.00	42.2 AV	54.0	-11.8	1.50 V	357	38.8	3.4
7	#10420.00	47.6 PK	68.2	-20.6	1.33 V	3	34.8	12.8
8	15630.00	43.1 PK	74.0	-30.9	1.58 V	24	29.4	13.7
9	15630.00	32.1 AV	54.0	-21.9	1.58 V	24	18.4	13.7

Remarks:

1. Emission Level(dBuV/m) = Raw Value(dBuV) + Correction Factor(dB/m)
2. Correction Factor(dB/m) = Antenna Factor(dB/m) + Cable Factor(dB) – Pre-Amplifier Factor(dB)
3. Margin value = Emission Level – Limit value
4. The other emission levels were very low against the limit.
5. " * ": Fundamental frequency.
6. " # ": The radiated frequency is out of the restricted band.

Channel	TX Channel 155	Detector Function	Peak (PK)
Frequency Range	1GHz ~ 40GHz		Average (AV)

Antenna Polarity & Test Distance : Horizontal at 3 m

No	Frequency (MHz)	Emission Level (dBuV/m)	Limit (dBuV/m)	Margin (dB)	Antenna Height (m)	Table Angle (Degree)	Raw Value (dBuV)	Correction Factor (dB/m)
1	*5775.00	109.3 PK			1.80 H	294	105.2	4.1
2	*5775.00	99.7 AV			1.80 H	294	95.6	4.1
3	11550.00	51.8 PK	74.0	-22.2	1.58 H	73	38.6	13.2
4	11550.00	46.0 AV	54.0	-8.0	1.58 H	73	32.8	13.2
5	#17325.00	52.9 PK	68.2	-15.3	1.15 H	2	35.3	17.6

Antenna Polarity & Test Distance : Vertical at 3 m

No	Frequency (MHz)	Emission Level (dBuV/m)	Limit (dBuV/m)	Margin (dB)	Antenna Height (m)	Table Angle (Degree)	Raw Value (dBuV)	Correction Factor (dB/m)
1	*5775.00	109.2 PK			3.08 V	348	105.1	4.1
2	*5775.00	100.8 AV			3.08 V	348	96.7	4.1
3	11550.00	46.8 PK	74.0	-27.2	1.58 V	3	33.6	13.2
4	11550.00	42.9 AV	54.0	-11.1	1.58 V	3	29.7	13.2
5	#17325.00	47.1 PK	68.2	-21.1	1.58 V	25	29.5	17.6

Remarks:

1. Emission Level(dBuV/m) = Raw Value(dBuV) + Correction Factor(dB/m)
2. Correction Factor(dB/m) = Antenna Factor(dB/m) + Cable Factor(dB) – Pre-Amplifier Factor(dB)
3. Margin value = Emission Level – Limit value
4. The other emission levels were very low against the limit.
5. " * ": Fundamental frequency.
6. " # ": The radiated frequency is out of the restricted band.

Below 1GHz Data:

802.11ac (VHT40)

CHANNEL	TX Channel 46	DETECTOR FUNCTION	Quasi-Peak (QP)
FREQUENCY RANGE	9kHz ~ 1GHz		

Antenna Polarity & Test Distance : Horizontal at 3 m								
No	Frequency (MHz)	Emission Level (dBuV/m)	Limit (dBuV/m)	Margin (dB)	Antenna Height (m)	Table Angle (Degree)	Raw Value (dBuV)	Correction Factor (dB/m)
1	33.90	31.6 QP	40.0	-8.4	2.00 H	107	40.3	-8.7
2	89.14	33.1 QP	43.5	-10.4	2.00 H	292	46.3	-13.2
3	126.98	38.0 QP	43.5	-5.5	1.50 H	285	46.5	-8.5
4	160.41	35.6 QP	43.5	-7.9	1.50 H	237	42.4	-6.8
5	198.97	35.7 QP	43.5	-7.8	1.00 H	80	45.8	-10.1
6	653.78	35.5 QP	46.0	-10.5	1.50 H	216	32.4	3.1

Remarks:

1. Emission Level(dBuV/m) = Raw Value(dBuV) + Correction Factor(dB/m)
2. Correction Factor(dB/m) = Antenna Factor(dB/m) + Cable Factor(dB) – Pre-Amplifier Factor(dB)
3. Margin value = Emission Level – Limit value
4. The other emission levels were very low against the limit of frequency range 30MHz~1000MHz.
5. The emission levels were very low against the limit of frequency range 9kHz~30MHz: the amplitude of spurious emissions attenuated more than 20 dB below the permissible value to be report.

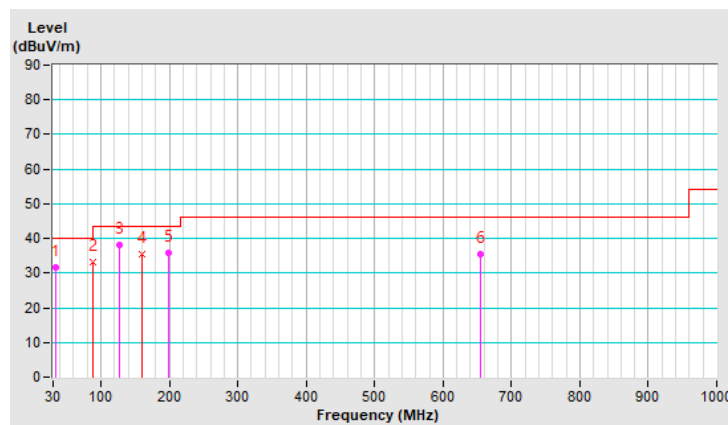

CHANNEL	TX Channel 46	DETECTOR FUNCTION	Quasi-Peak (QP)
FREQUENCY RANGE	9kHz ~ 1GHz		

Antenna Polarity & Test Distance : Vertical at 3 m

No	Frequency (MHz)	Emission Level (dBuV/m)	Limit (dBuV/m)	Margin (dB)	Antenna Height (m)	Table Angle (Degree)	Raw Value (dBuV)	Correction Factor (dB/m)
1	33.81	37.0 QP	40.0	-3.0	1.00 V	218	45.7	-8.7
2	67.12	36.8 QP	40.0	-3.2	1.00 V	246	46.0	-9.2
3	94.17	36.5 QP	43.5	-7.0	1.00 V	135	49.2	-12.7
4	127.05	39.1 QP	43.5	-4.4	1.00 V	188	47.6	-8.5
5	154.74	38.1 QP	43.5	-5.4	1.00 V	228	44.9	-6.8
6	205.35	33.8 QP	43.5	-9.7	1.00 V	26	43.7	-9.9

Remarks:

1. Emission Level(dBuV/m) = Raw Value(dBuV) + Correction Factor(dB/m)
2. Correction Factor(dB/m) = Antenna Factor(dB/m) + Cable Factor(dB) – Pre-Amplifier Factor(dB)
3. Margin value = Emission Level – Limit value
4. The other emission levels were very low against the limit of frequency range 30MHz~1000MHz.
5. The emission levels were very low against the limit of frequency range 9kHz~30MHz: the amplitude of spurious emissions attenuated more than 20 dB below the permissible value to be report.

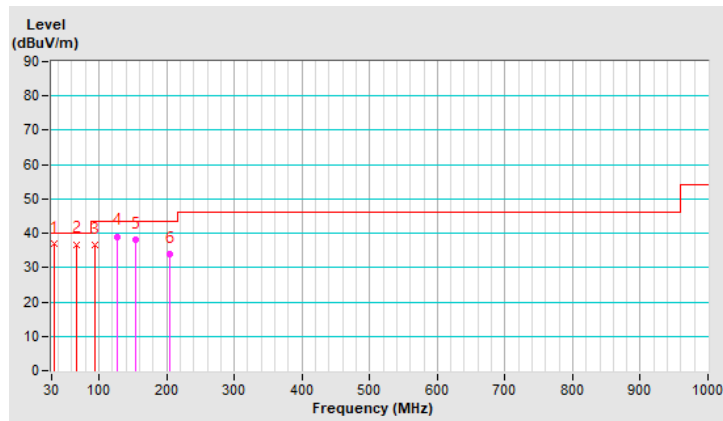

4.2 Conducted Emission Measurement

4.2.1 Limits of Conducted Emission Measurement

Frequency (MHz)	Conducted Limit (dBuV)	
	Quasi-peak	Average
0.15 - 0.5	66 - 56	56 - 46
0.50 - 5.0	56	46
5.0 - 30.0	60	50

Note: 1. The lower limit shall apply at the transition frequencies.

2. The limit decreases in line with the logarithm of the frequency in the range of 0.15 to 0.50MHz.

4.2.2 Test Instruments

DESCRIPTION & MANUFACTURER	MODEL NO.	SERIAL NO.	CALIBRATED DATE	CALIBRATED UNTIL
Test Receiver R&S	ESCS 30	847124/029	Oct. 23, 2019	Oct. 22, 2020
Line-Impedance Stabilization Network (for EUT) R&S	ESH3-Z5	848773/004	Oct. 23, 2019	Oct. 22, 2020
Line-Impedance Stabilization Network (for Peripheral) R&S	ESH3-Z5	835239/001	Mar. 19, 2020	Mar. 18, 2021
50 ohms Terminator	50	3	Oct. 23, 2019	Oct. 22, 2020
RF Cable	5D-FB	COCCAB-001	Sep. 27, 2019	Sep. 26, 2020
Fixed attenuator EMCI	STI02-2200-10	005	Aug. 30, 2019	Aug. 29, 2020
Software BVADT	BVADT_Cond_ V7.3.7.4	NA	NA	NA

Note:

1. The calibration interval of the above test instruments are 12 months and the calibrations are traceable to NML/ROC and NIST/USA.
2. The test was performed in Conduction 1.
- 3 Tested Date: June 11, 2020

4.2.3 Test Procedure

- The EUT was placed 0.4 meters from the conducting wall of the shielded room with EUT being connected to the power mains through a line impedance stabilization network (LISN). Other support units were connected to the power mains through another LISN. The two LISNs provide 50 ohm/ 50uH of coupling impedance for the measuring instrument.
- Both lines of the power mains connected to the EUT were checked for maximum conducted interference.
- The frequency range from 150kHz to 30MHz was searched. Emission levels under (Limit - 20dB) was not recorded.

NOTE: All modes of operation were investigated and the worst-case emissions are reported.

4.2.4 Deviation from Test Standard

No deviation.

4.2.5 Test Setup

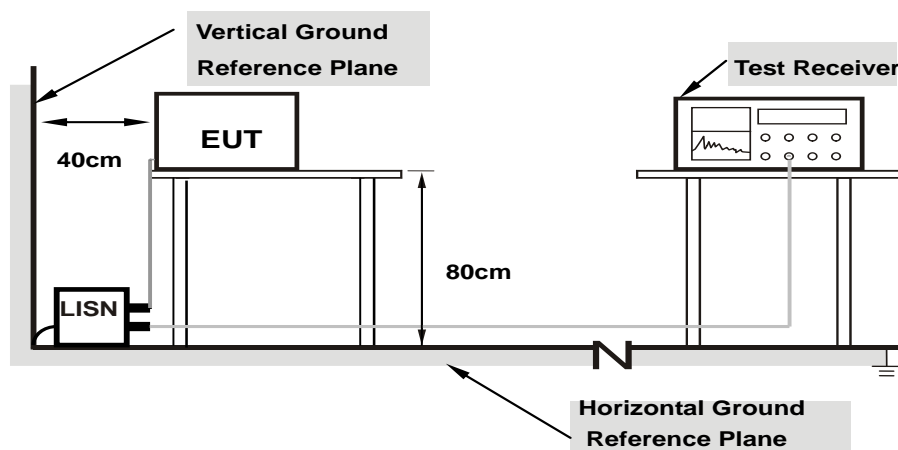

Note: 1.Support units were connected to second LISN.

For the actual test configuration, please refer to the attached file (Test Setup Photo).

4.2.6 EUT Operating Condition

Same as 4.1.6.

4.2.7 Test Results

Phase	Line (L)	Detector Function	Quasi-Peak (QP) / Average (AV)
-------	----------	-------------------	--------------------------------

Phase Of Power : Line (L)										
No	Frequency (MHz)	Correction Factor (dB)	Reading Value (dBuV)		Emission Level (dBuV)		Limit (dBuV)		Margin (dB)	
			Q.P.	AV.	Q.P.	AV.	Q.P.	AV.	Q.P.	AV.
1	0.21641	10.02	30.94	18.58	40.96	28.60	62.96	52.96	-22.00	-24.36
2	0.24375	10.02	33.38	17.83	43.40	27.85	61.97	51.97	-18.57	-24.12
3	0.36484	10.03	27.82	13.66	37.85	23.69	58.62	48.62	-20.77	-24.93
4	0.59141	10.04	28.03	9.64	38.07	19.68	56.00	46.00	-17.93	-26.32
5	13.09766	10.76	29.34	16.26	40.10	27.02	60.00	50.00	-19.90	-22.98
6	21.54688	11.20	27.69	18.11	38.89	29.31	60.00	50.00	-21.11	-20.69

Remarks:

1. Q.P. and AV. are abbreviations of quasi-peak and average individually.
2. The emission levels of other frequencies were very low against the limit.
3. Margin value = Emission level – Limit value
4. Correction factor = Insertion loss + Cable loss
5. Emission Level = Correction Factor + Reading Value

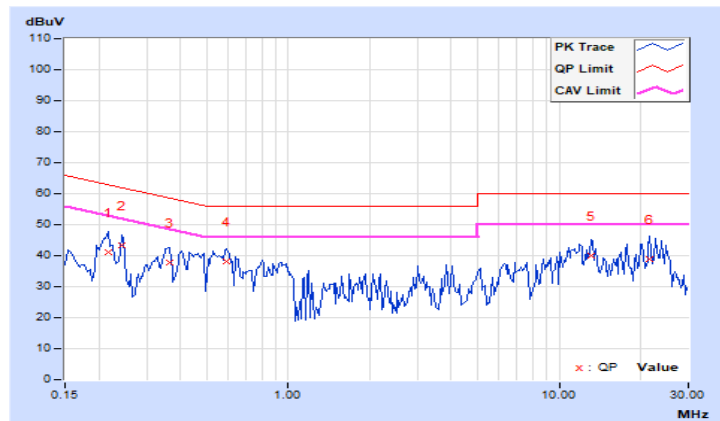

Phase	Neutral (N)	Detector Function	Quasi-Peak (QP) / Average (AV)
-------	-------------	-------------------	--------------------------------

Phase Of Power : Neutral (N)										
No	Frequency (MHz)	Correction Factor (dB)	Reading Value (dBuV)		Emission Level (dBuV)		Limit (dBuV)		Margin (dB)	
			Q.P.	AV.	Q.P.	AV.	Q.P.	AV.	Q.P.	AV.
1	0.20859	10.01	30.02	15.70	40.03	25.71	63.26	53.26	-23.23	-27.55
2	0.24375	10.01	32.00	18.21	42.01	28.22	61.97	51.97	-19.96	-23.75
3	0.54844	10.02	20.71	6.00	30.73	16.02	56.00	46.00	-25.27	-29.98
4	12.49219	10.58	25.44	12.78	36.02	23.36	60.00	50.00	-23.98	-26.64
5	17.55469	10.78	27.10	16.86	37.88	27.64	60.00	50.00	-22.12	-22.36
6	23.93359	10.98	25.07	18.38	36.05	29.36	60.00	50.00	-23.95	-20.64

Remarks:

1. Q.P. and AV. are abbreviations of quasi-peak and average individually.
2. The emission levels of other frequencies were very low against the limit.
3. Margin value = Emission level – Limit value
4. Correction factor = Insertion loss + Cable loss
5. Emission Level = Correction Factor + Reading Value

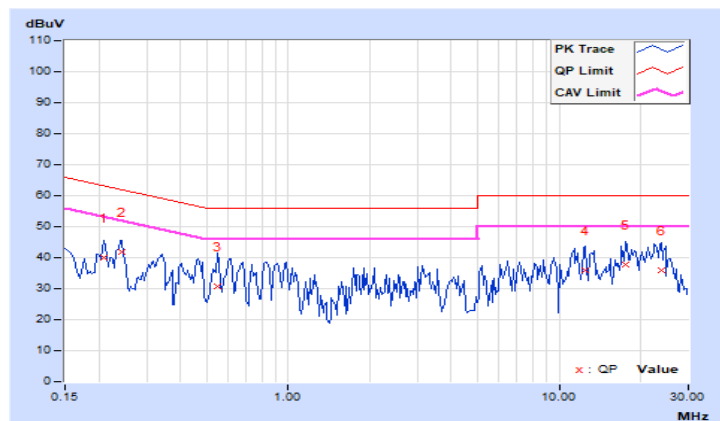

4.3 Transmit Power Measurement

4.3.1 Limits of Transmit Power Measurement

Operation Band	EUT Category		Limit
U-NII-1		Outdoor Access Point	1 Watt (30 dBm) (Max. e.i.r.p \leq 125mW(21 dBm) at any elevation angle above 30 degrees as measured from the horizon)
		Fixed point-to-point Access Point	1 Watt (30 dBm)
	√	Indoor Access Point	1 Watt (30 dBm)
		Client device	250mW (24 dBm)
U-NII-2A			250mW (24 dBm) or 11 dBm+10 log B*
U-NII-2C			250mW (24 dBm) or 11 dBm+10 log B*
U-NII-3	√		1 Watt (30 dBm)

*B is the 26 dB emission bandwidth in megahertz

Per KDB 662911 Method of conducted output power measurement on IEEE 802.11 devices,

Array Gain = 0 dB (i.e., no array gain) for $N_{ANT} \leq 4$;

Array Gain = 0 dB (i.e., no array gain) for channel widths ≥ 40 MHz for any N_{ANT} ;

Array Gain = $5 \log(N_{ANT}/N_{SS})$ dB or 3 dB, whichever is less for 20-MHz channel widths with $N_{ANT} \geq 5$.

For power measurements on all other devices: Array Gain = $10 \log(N_{ANT}/N_{SS})$ dB.

4.3.2 Test Setup

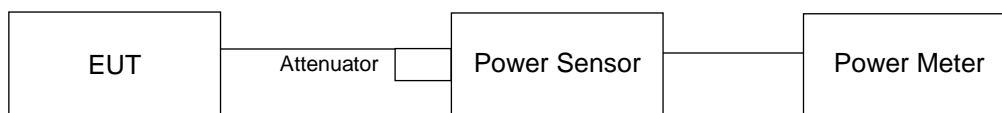

4.3.3 Test Instruments

Refer to section 4.1.2 to get information of above instrument.

4.3.4 Test Procedure

Method PM is used to perform output power measurement, trigger and gating function of wide band power meter is enabled to measure max output power of TX on burst. Duty factor is not added to measured value.

4.3.5 Deviation from Test Standard

No deviation.

4.3.6 EUT Operating Condition

The software provided by client to enable the EUT under transmission condition continuously at lowest, middle and highest channel frequencies individually.

4.3.7 Test Results

CDD Mode

802.11a

Chan.	Chan. Freq. (MHz)	Maximum Conducted Power (dBm)		Total Power (mW)	Total Power (dBm)	Limit (dBm)	Pass / Fail
		Chain 0	Chain 1				
36	5180	23.91	23.94	493.779	26.94	30.00	Pass
40	5200	25.97	25.65	762.649	28.82	30.00	Pass
48	5240	25.74	25.56	734.722	28.66	30.00	Pass
149	5745	25.82	25.87	768.311	28.86	30.00	Pass
157	5785	25.71	25.84	756.099	28.79	30.00	Pass
165	5825	25.84	25.77	761.279	28.82	30.00	Pass

802.11ac (VHT20)

Chan.	Chan. Freq. (MHz)	Maximum Conducted Power (dBm)		Total Power (mW)	Total Power (dBm)	Limit (dBm)	Pass / Fail
		Chain 0	Chain 1				
36	5180	23.96	23.61	478.501	26.80	30.00	Pass
40	5200	26.03	25.66	768.996	28.86	30.00	Pass
48	5240	25.83	25.63	748.42	28.74	30.00	Pass
149	5745	25.88	25.89	775.408	28.90	30.00	Pass
157	5785	25.72	25.96	767.707	28.85	30.00	Pass
165	5825	25.91	25.67	758.92	28.80	30.00	Pass

802.11ac (VHT40)

Chan.	Chan. Freq. (MHz)	Maximum Conducted Power (dBm)		Total Power (mW)	Total Power (dBm)	Limit (dBm)	Pass / Fail
		Chain 0	Chain 1				
38	5190	22.16	22.29	333.871	25.24	30.00	Pass
46	5230	25.81	26.03	781.933	28.93	30.00	Pass
151	5755	25.67	26.03	769.844	28.86	30.00	Pass
159	5795	25.51	26.13	765.835	28.84	30.00	Pass

802.11ac (VHT80)

Chan.	Chan. Freq. (MHz)	Maximum Conducted Power (dBm)		Total Power (mW)	Total Power (dBm)	Limit (dBm)	Pass / Fail
		Chain 0	Chain 1				
42	5210	21.37	21.53	279.321	24.46	30.00	Pass
155	5775	21.92	22.17	320.413	25.06	30.00	Pass

Beamforming Mode

802.11ac (VHT20)

Chan.	Chan. Freq. (MHz)	Maximum Conducted Power (dBm)		Total Power (mW)	Total Power (dBm)	Limit (dBm)	Pass / Fail
		Chain 0	Chain 1				
36	5180	23.96	23.61	478.501	26.80	30.00	Pass
40	5200	26.03	25.66	768.996	28.86	30.00	Pass
48	5240	25.83	25.63	748.42	28.74	30.00	Pass
149	5745	25.88	25.89	775.408	28.90	30.00	Pass
157	5785	25.72	25.96	767.707	28.85	30.00	Pass
165	5825	25.91	25.67	758.92	28.80	30.00	Pass

Note: 1. The directional gain = $10 \log[(10^{G0/20} + 10^{G1/20})^2 / 2] = 5.98 \text{ dBi} < 6 \text{ dBi}$, so the power limit shall not be reduced.

802.11ac (VHT40)

Chan.	Chan. Freq. (MHz)	Maximum Conducted Power (dBm)		Total Power (mW)	Total Power (dBm)	Limit (dBm)	Pass / Fail
		Chain 0	Chain 1				
38	5190	22.16	22.29	333.871	25.24	30.00	Pass
46	5230	25.81	26.03	781.933	28.93	30.00	Pass
151	5755	25.67	26.03	769.844	28.86	30.00	Pass
159	5795	25.51	26.13	765.835	28.84	30.00	Pass

Note: 1. The directional gain = $10 \log[(10^{G0/20} + 10^{G1/20})^2 / 2] = 5.98 \text{ dBi} < 6 \text{ dBi}$, so the power limit shall not be reduced.

802.11ac (VHT80)

Chan.	Chan. Freq. (MHz)	Maximum Conducted Power (dBm)		Total Power (mW)	Total Power (dBm)	Limit (dBm)	Pass / Fail
		Chain 0	Chain 1				
42	5210	21.37	21.53	279.321	24.46	30.00	Pass
155	5775	21.92	22.17	320.413	25.06	30.00	Pass

Note: 1. The directional gain = $10 \log[(10^{G0/20} + 10^{G1/20})^2 / 2] = 5.98 \text{ dBi} < 6 \text{ dBi}$, so the power limit shall not be reduced.

4.4 Occupied Bandwidth Measurement

4.4.1 Test Setup

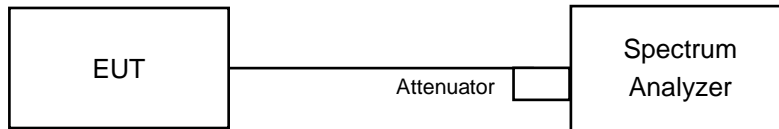

4.4.2 Test Instruments

Refer to section 4.1.2 to get information of above instrument.

4.4.3 Test Procedure

The transmitter output was connected to the spectrum analyzer through an attenuator. The bandwidth of the fundamental frequency was measured by spectrum analyzer with resolution bandwidth in the range of 1% to 5% of the anticipated emission bandwidth, and a video bandwidth at least 3x the resolution bandwidth and set the detector to SAMPLE. The width of a frequency band such that, below the lower and above the upper frequency limits, the mean powers emitted are each equal to a specified percentage 0.5% of the total mean power of a given emission.

4.4.4 Test Results

CDD Mode

802.11a

Channel	Channel Frequency (MHz)	Occupied Bandwidth (MHz)	
		Chain 0	Chain 1
36	5180	16.56	16.56
40	5200	17.28	16.8
48	5240	16.92	16.92
149	5745	20.04	24.48
157	5785	22.92	26.52
165	5825	24.84	27.24

802.11ac (VHT20)

Channel	Channel Frequency (MHz)	Occupied Bandwidth (MHz)	
		Chain 0	Chain 1
36	5180	17.76	17.76
40	5200	17.88	17.88
48	5240	17.88	18
149	5745	19.68	20.52
157	5785	22.56	24.6
165	5825	25.2	27.36

802.11ac (VHT40)

Channel	Channel Frequency (MHz)	Occupied Bandwidth (MHz)	
		Chain 0	Chain 1
38	5190	36.24	36
46	5230	36.48	36.24
151	5755	37.68	48.24
159	5795	42.24	52.56

802.11ac (VHT80)

Channel	Channel Frequency (MHz)	Occupied Bandwidth (MHz)	
		Chain 0	Chain 1
42	5210	75.84	75.84
155	5775	75.84	76.32

Spectrum Plot of Max. Value

802.11a_Chain 1 / CH165

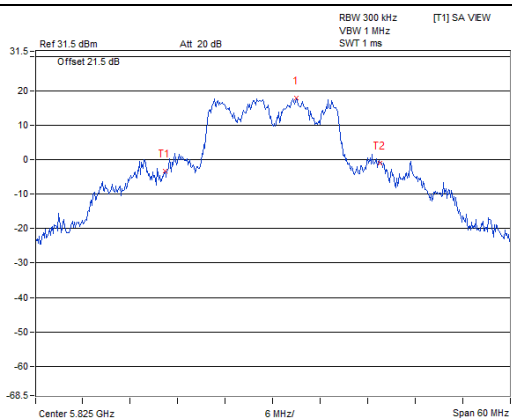

RBW 300 kHz [T1] SA VIEW
 VBW 1 MHz
 SWT 1 ms
 Marker 1 [T1]
 17.82 dBm
 5.82800 GHz
 27.24 MHz
 OBW
 -3.32 dBm
 5.81132 GHz
 Temp 1 [T1] OBW
 -0.94 dBm
 5.83856 GHz

802.11ac (VHT20)_Chain 1 / CH165

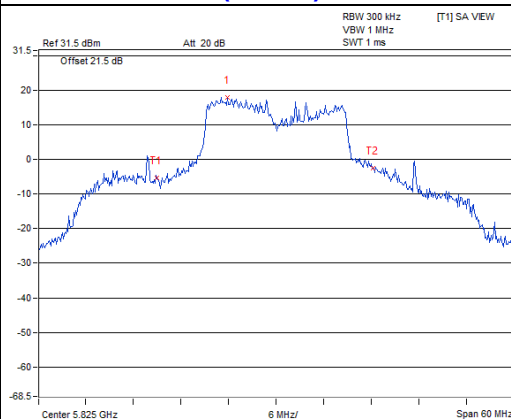

RBW 300 kHz [T1] SA VIEW
 VBW 1 MHz
 SWT 1 ms
 Marker 1 [T1]
 18.03 dBm
 5.81878 GHz
 27.36 MHz
 OBW
 -5.28 dBm
 5.80688 GHz
 Temp 2 [T1] OBW
 -2.49 dBm
 5.83724 GHz

802.11ac (VHT40)_Chain 1 / CH159

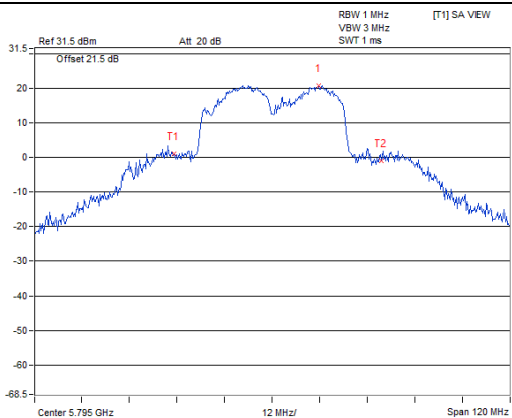

RBW 1 MHz [T1] SA VIEW
 VBW 3 MHz
 SWT 1 ms
 Marker 1 [T1]
 20.81 dBm
 5.80676 GHz
 52.56 MHz
 OBW
 1.11 dBm
 5.77004 GHz
 Temp 2 [T1] OBW
 -0.98 dBm
 5.82260 GHz

802.11ac (VHT80)_Chain 1 / CH155

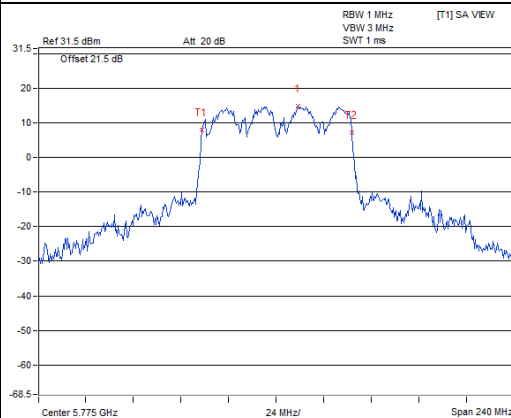

RBW 1 MHz [T1] SA VIEW
 VBW 3 MHz
 SWT 1 ms
 Marker 1 [T1]
 14.90 dBm
 5.78604 GHz
 76.32 MHz
 OBW
 7.87 dBm
 5.73708 GHz
 Temp 2 [T1] OBW
 7.15 dBm
 5.81340 GHz

Spectrum Plot for near by DFS band
(DFS is required, if 99% OCP straddle into U-NII-2A band)

802.11a_Chain 0 / CH48

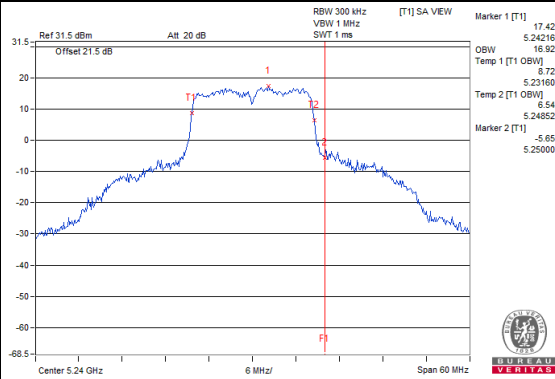

802.11a_Chain 1 / CH48

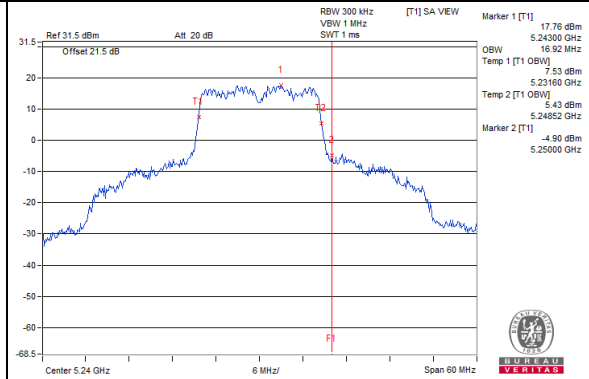

802.11ac (VHT20)_Chain 0 / CH48

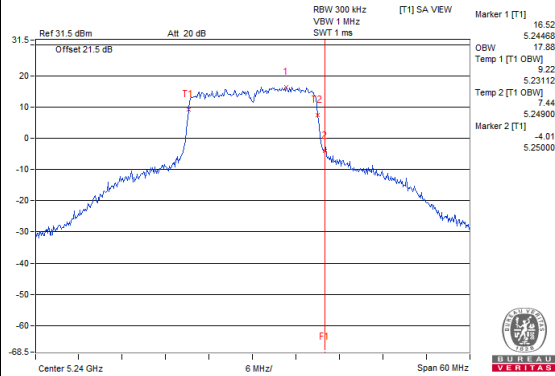

802.11ac (VHT20)_Chain 1 / CH48

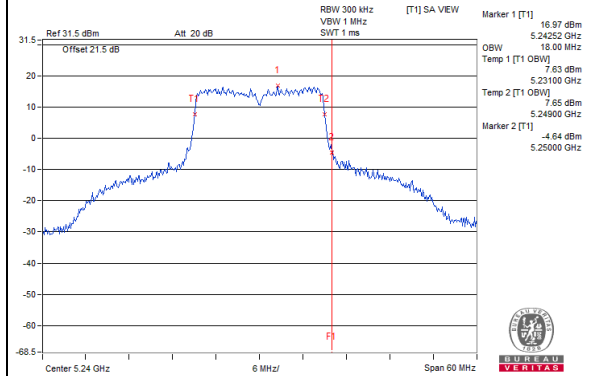

802.11ac (VHT40)_Chain 0 / CH46

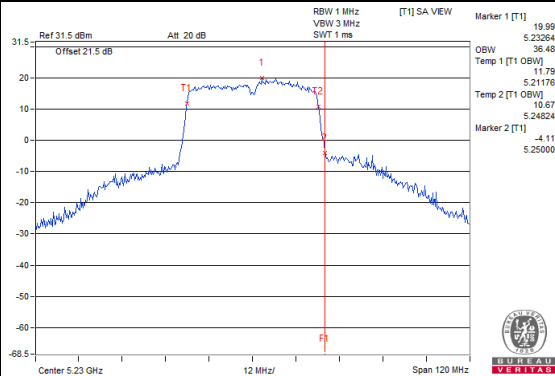

802.11ac (VHT40)_Chain 1 / CH46

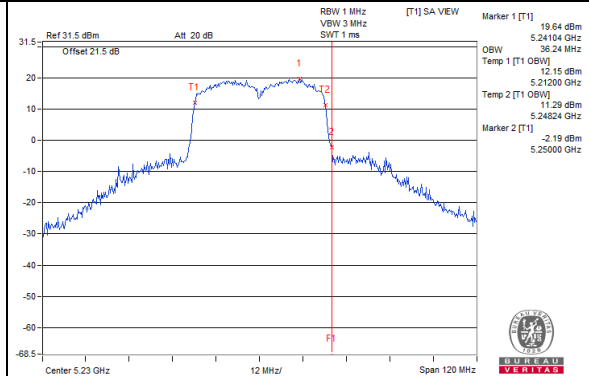

802.11ac (VHT80)_Chain 0 / CH42

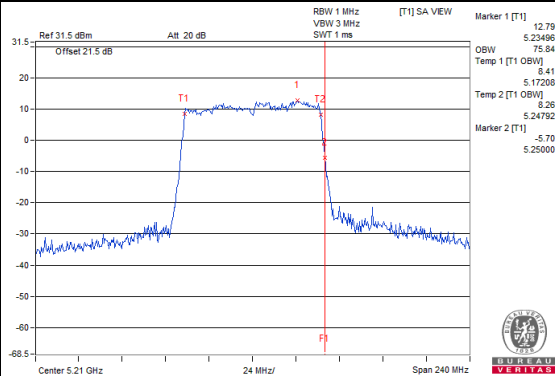

802.11ac (VHT80)_Chain 1 / CH42

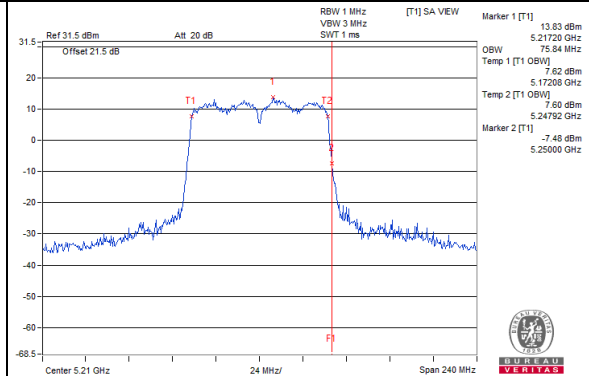

Spectrum Plot for near by DFS band
(DFS is required, if 99% OCP straddle into U-NII-2C band)

802.11a_Chain 0 / CH149

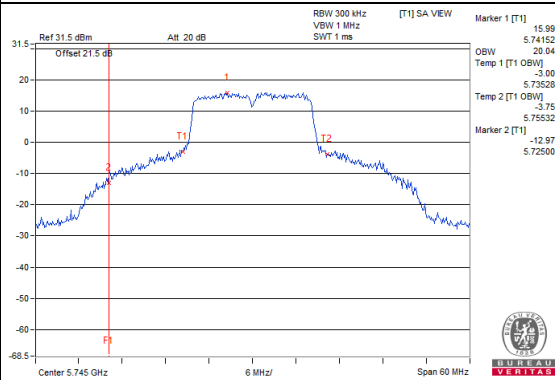

802.11a_Chain 1 / CH149

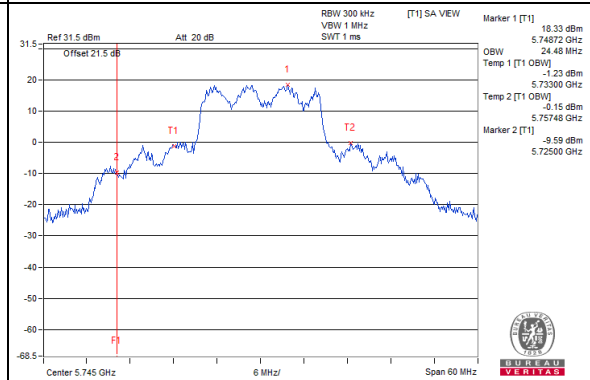

802.11ac (VHT20)_Chain 0 / CH149

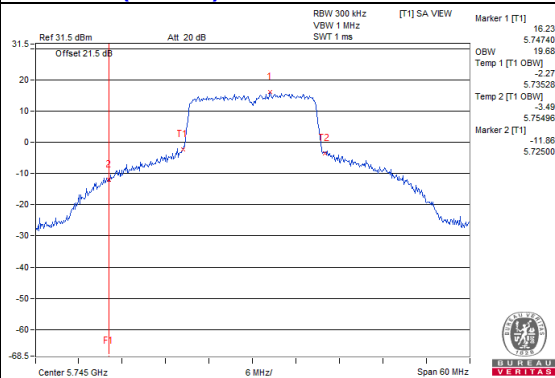

802.11ac (VHT20)_Chain 1 / CH149

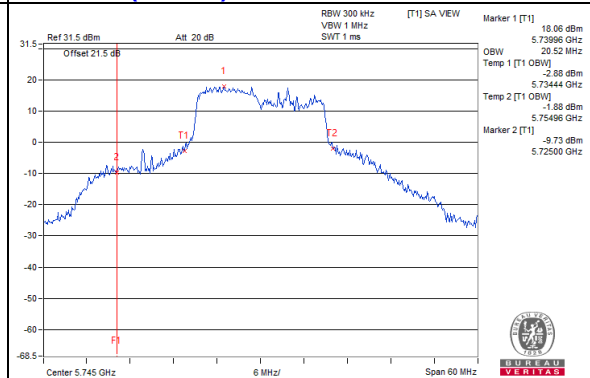

802.11ac (VHT40)_Chain 0 / CH151

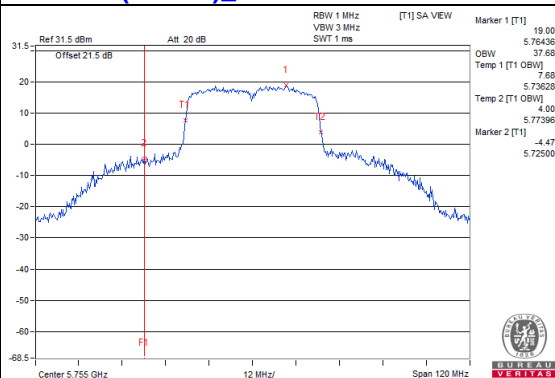

802.11ac (VHT40)_Chain 1 / CH151

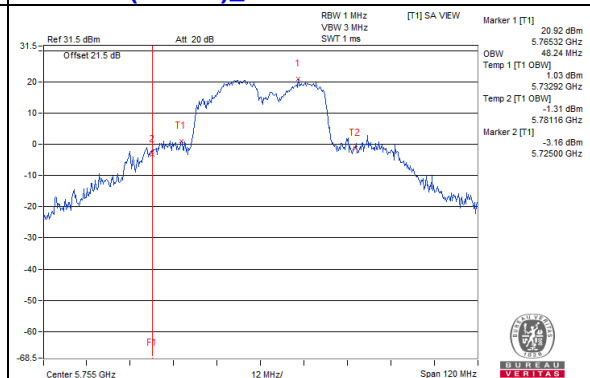

802.11ac (VHT80)_Chain 0 / CH155

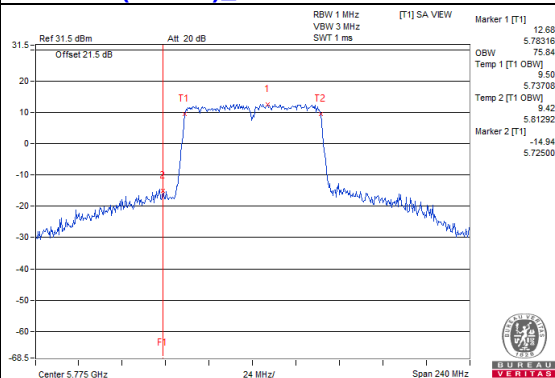

802.11ac (VHT80)_Chain 1 / CH155

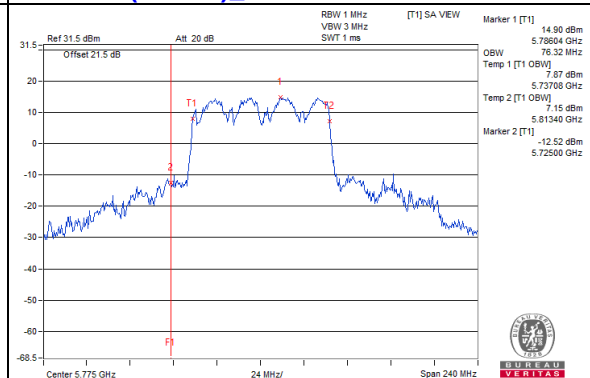

4.5 Peak Power Spectral Density Measurement

4.5.1 Limits of Peak Power Spectral Density Measurement

Operation Band	EUT Category		Limit
U-NII-1		Outdoor Access Point	17dBm/ MHz
		Fixed point-to-point Access Point	
	√	Indoor Access Point	
		Client device	
U-NII-2A			11dBm/ MHz
U-NII-2C			11dBm/ MHz
U-NII-3		√	30dBm/ 500kHz

4.5.2 Test Setup

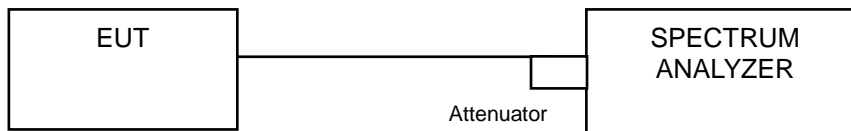

4.5.3 Test Instruments

Refer to section 4.1.2 to get information of above instrument.

4.5.4 Test Procedure

For 802.11ac (VHT20)

For U-NII-1 band:

Using method SA-1

1. Set span to encompass the entire emission bandwidth (EBW) of the signal.
2. Set RBW = 1 MHz, Set VBW ≥ 3 MHz, Detector = RMS
3. Sweep time = auto, trigger set to "free run".
4. Trace average at least 100 traces in power averaging mode.
5. Record the max value

For U-NII-3:

1. Set span to encompass the entire emission bandwidth (EBW) of the signal.
2. Set RBW = 300 kHz, Set VBW ≥ 1 MHz, Detector = RMS
3. Use the peak marker function to determine the maximum power level in any 300 kHz band segment within the fundamental EBW.
4. Scale the observed power level to an equivalent value in 500 kHz by adjusting (reducing) the measured power by a bandwidth correction factor (BWCF) where $BWCF = 10\log(500\text{ kHz}/300\text{ kHz})$
5. Sweep time = auto, trigger set to "free run".
6. Trace average at least 100 traces in power averaging mode.
7. Record the max value

For other modulation mode:

For U-NII-1 band:

Using method SA-2

1. Set span to encompass the entire emission bandwidth (EBW) of the signal.
2. Set RBW = 1 MHz, Set VBW \geq 3 MHz, Detector = RMS
3. Sweep time = auto, trigger set to "free run".
4. Trace average at least 100 traces in power averaging mode.
5. Record the max value and add $10 \log (1/\text{duty cycle})$

For U-NII-3:

1. Set span to encompass the entire emission bandwidth (EBW) of the signal.
2. Set RBW = 300 kHz, Set VBW \geq 1 MHz, Detector = RMS
3. Use the peak marker function to determine the maximum power level in any 300 kHz band segment within the fundamental EBW.
4. Scale the observed power level to an equivalent value in 500 kHz by adjusting (reducing) the measured power by a bandwidth correction factor (BWCF) where $\text{BWCF} = 10 \log(500 \text{ kHz}/300 \text{ kHz})$
5. Sweep time = auto, trigger set to "free run".
6. Trace average at least 100 traces in power averaging mode.
7. Record the max value and add $10 \log (1/\text{duty cycle})$

4.5.5 Deviation from Test Standard

No deviation.

4.5.6 EUT Operating Condition

Same as Item 4.3.6.

4.5.7 Test Results

For U-NII-1:

CDD Mode

802.11a

Chan.	Chan. Freq. (MHz)	PSD w/o Duty Factor (dBm/MHz)		Duty Factor (dB)	Total PSD (dBm/MHz)	Max. PSD Limit (dBm/MHz)	Pass / Fail
		Chain 0	Chain 1				
36	5180	10.60	11.49	0.21	14.29	17.00	PASS
40	5200	12.26	13.12	0.21	15.93	17.00	PASS
48	5240	12.96	12.61	0.21	16.01	17.00	PASS

- Note: 1. Method a) of power density measurement of KDB 662911 is using for calculating total power density. Total power density is summing entire spectra across corresponding frequency bins on the various outputs by computer.
2. The directional gain = $10 \log[(10^{G0/20} + 10^{G1/20})^2 / 2] = 5.98 \text{dBi} < 6 \text{dBi}$, so the power density limit shall not be reduced.
3. Refer to section 3.3 for duty cycle spectrum plot.

802.11ac (VHT20)

Chan.	Chan. Freq. (MHz)	PSD w/o Duty Factor (dBm/MHz)		Total PSD (dBm/MHz)	Max. PSD Limit (dBm/MHz)	Pass / Fail
		Chain 0	Chain 1			
36	5180	9.90	10.99	13.49	17.00	PASS
40	5200	12.55	11.23	14.95	17.00	PASS
48	5240	12.23	12.13	15.19	17.00	PASS

- Note: 1. Method a) of power density measurement of KDB 662911 is using for calculating total power density. Total power density is summing entire spectra across corresponding frequency bins on the various outputs by computer.
2. The directional gain = $10 \log[(10^{G0/20} + 10^{G1/20})^2 / 2] = 5.98 \text{dBi} < 6 \text{dBi}$, so the power density limit shall not be reduced.

802.11ac (VHT40)

Chan.	Chan. Freq. (MHz)	PSD w/o Duty Factor (dBm/MHz)		Duty Factor (dB)	Total PSD (dBm/MHz)	Max. PSD Limit (dBm/MHz)	Pass / Fail
		Chain 0	Chain 1				
38	5190	5.87	6.98	0.16	9.63	17.00	PASS
46	5230	9.57	9.10	0.16	12.51	17.00	PASS

- Note: 1. Method a) of power density measurement of KDB 662911 is using for calculating total power density. Total power density is summing entire spectra across corresponding frequency bins on the various outputs by computer.
2. The directional gain = $10 \log[(10^{G0/20} + 10^{G1/20})^2 / 2] = 5.98 \text{dBi} < 6 \text{dBi}$, so the power density limit shall not be reduced.
3. Refer to section 3.3 for duty cycle spectrum plot.

802.11ac (VHT80)

Chan.	Chan. Freq. (MHz)	PSD w/o Duty Factor (dBm/MHz)		Duty Factor (dB)	Total PSD (dBm/MHz)	Max. PSD Limit (dBm/MHz)	Pass / Fail
		Chain 0	Chain 1				
42	5210	2.41	1.45	0.30	5.27	17.00	PASS

- Note: 1. Method a) of power density measurement of KDB 662911 is using for calculating total power density. Total power density is summing entire spectra across corresponding frequency bins on the various outputs by computer.
2. The directional gain = $10 \log[(10^{G0/20} + 10^{G1/20})^2 / 2] = 5.98\text{dBi} < 6 \text{ dBi}$, so the power density limit shall not be reduced.
3. Refer to section 3.3 for duty cycle spectrum plot.

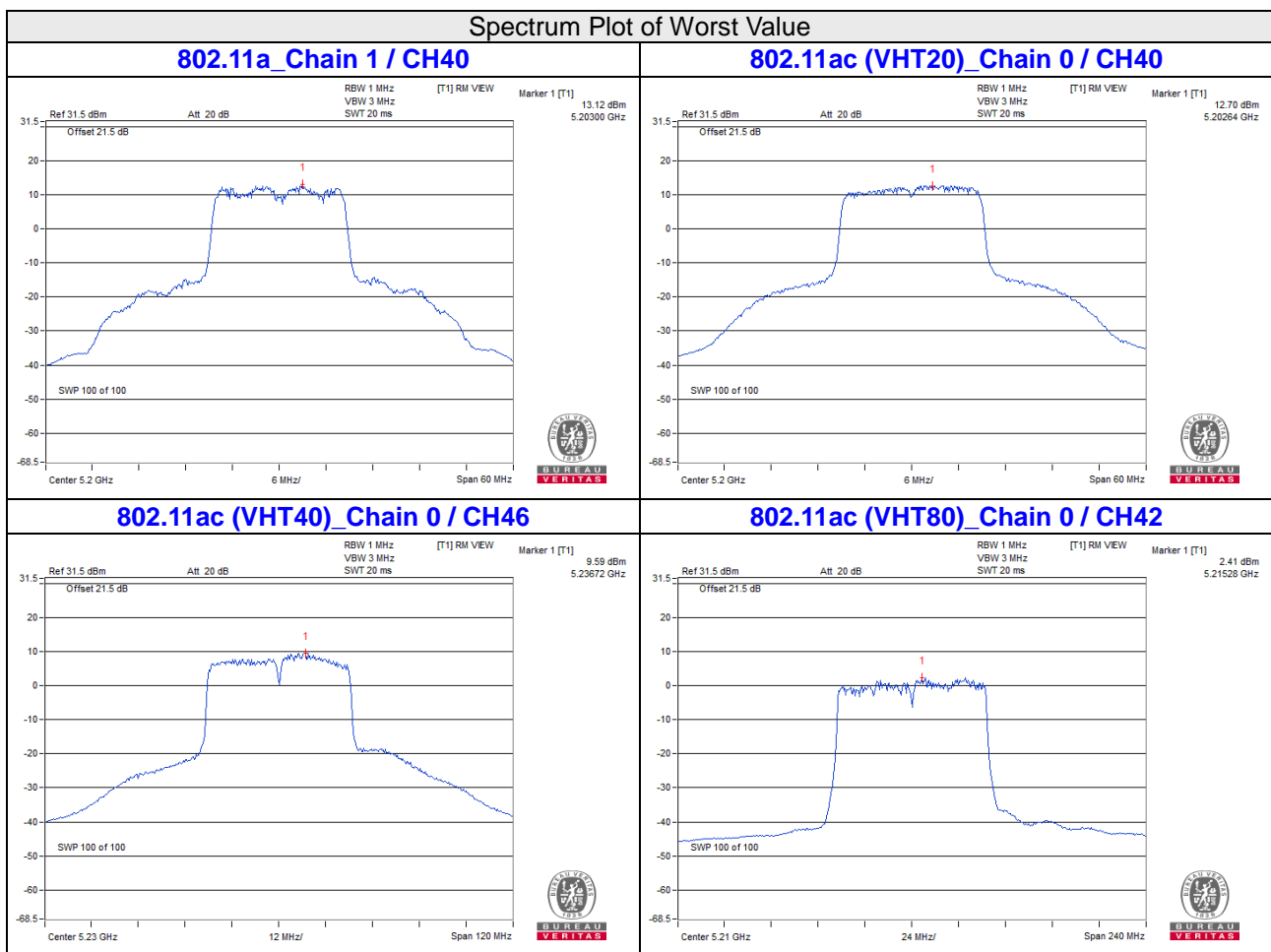

For U-NII-3:

CDD Mode

802.11a

Chan.	Chan. Freq. (MHz)	PSD w/o Duty Factor (dBm/300kHz)		Duty Factor (dB)	Total PSD (mW/300kHz)	Total PSD (dBm/300kHz)	Total PSD (dBm/500kHz)	PSD Limit (dBm/500kHz)	Pass / Fail
		Chain 0	Chain 1						
149	5745	2.88	4.74	0.21	5.164	7.13	9.35	30.00	PASS
157	5785	3.10	4.97	0.21	5.445	7.36	9.58	30.00	PASS
165	5825	3.62	5.19	0.21	5.888	7.70	9.92	30.00	PASS

- Note: 1. Method b) Measure and sum spectral maxima across the outputs of KDB 662911 is using for calculating total power density.
 2. The directional gain = $10 \log[(10^{G0/20} + 10^{G1/20})^2 / 2] = 5.98\text{dBi} < 6 \text{ dBi}$, so the power density limit shall not be reduced.
 3. Refer to section 3.3 for duty cycle spectrum plot.

802.11ac (VHT20)

Chan.	Chan. Freq. (MHz)	PSD w/o Duty Factor (dBm/300kHz)		Total PSD (mW/300kHz)	Total PSD (dBm/300kHz)	Total PSD (dBm/500kHz)	PSD Limit (dBm/500kHz)	Pass / Fail
		Chain 0	Chain 1					
149	5745	2.83	4.67	4.853	6.86	9.08	30.00	PASS
157	5785	2.85	4.89	5.012	7.00	9.22	30.00	PASS
165	5825	3.16	4.76	5.058	7.04	9.26	30.00	PASS

- Note: 1. Method b) Measure and sum spectral maxima across the outputs of KDB 662911 is using for calculating total power density.
 2. The directional gain = $10 \log[(10^{G0/20} + 10^{G1/20})^2 / 2] = 5.98\text{dBi} < 6 \text{ dBi}$, so the power density limit shall not be reduced.

802.11ac (VHT40)

Chan.	Chan. Freq. (MHz)	PSD w/o Duty Factor (dBm/300kHz)		Duty Factor (dB)	Total PSD (mW/300kHz)	Total PSD (dBm/300kHz)	Total PSD (dBm/500kHz)	PSD Limit (dBm/500kHz)	Pass / Fail
		Chain 0	Chain 1						
151	5755	-0.49	1.45	0.16	2.3768	3.76	5.98	30.00	PASS
159	5795	-0.31	1.65	0.16	2.4831	3.95	6.17	30.00	PASS

- Note: 1. Method b) Measure and sum spectral maxima across the outputs of KDB 662911 is using for calculating total power density.
 2. The directional gain = $10 \log[(10^{G0/20} + 10^{G1/20})^2 / 2] = 5.98\text{dBi} < 6 \text{ dBi}$, so the power density limit shall not be reduced.
 3. Refer to section 3.3 for duty cycle spectrum plot.

802.11ac (VHT80)

Chan.	Chan. Freq. (MHz)	PSD w/o Duty Factor (dBm/300kHz)		Duty Factor (dB)	Total PSD (mW/300kHz)	Total PSD (dBm/300kHz)	Total PSD (dBm/500kHz)	PSD Limit (dBm/500kHz)	Pass / Fail
		Chain 0	Chain 1						
155	5775	-6.22	-4.12	0.30	0.6714	-1.73	0.49	30.00	PASS

- Note: 1. Method b) Measure and sum spectral maxima across the outputs of KDB 662911 is using for calculating total power density.
 2. The directional gain = $10 \log[(10^{G0/20} + 10^{G1/20})^2 / 2] = 5.98\text{dBi} < 6 \text{ dBi}$, so the power density limit shall not be reduced.
 3. Refer to section 3.3 for duty cycle spectrum plot.

Spectrum Plot of Worst Value

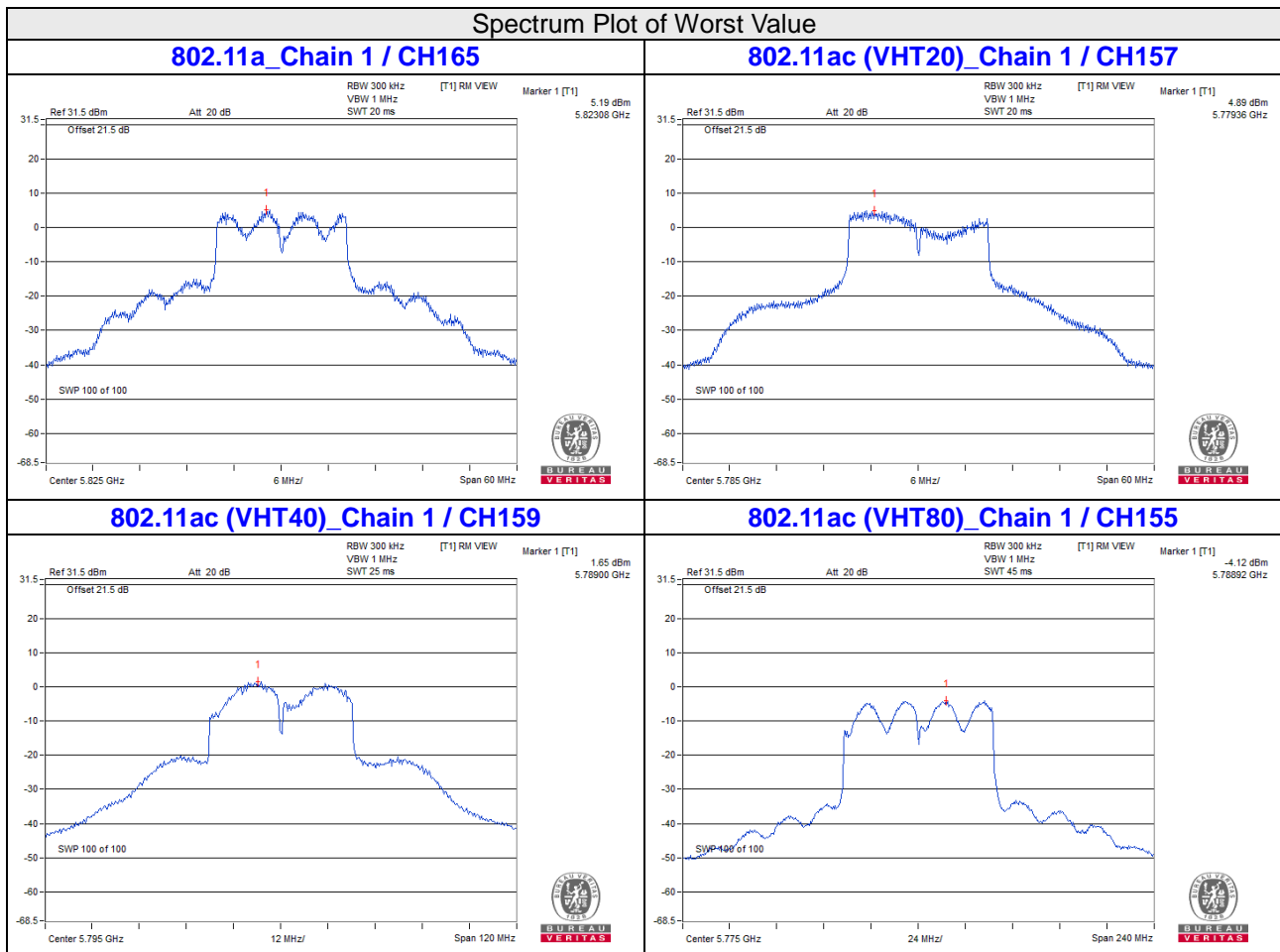

4.6 Frequency Stability Measurement

4.6.1 Limits of Frequency Stability Measurement

The frequency of the carrier signal shall be maintained within band of operation

4.6.2 Test Setup

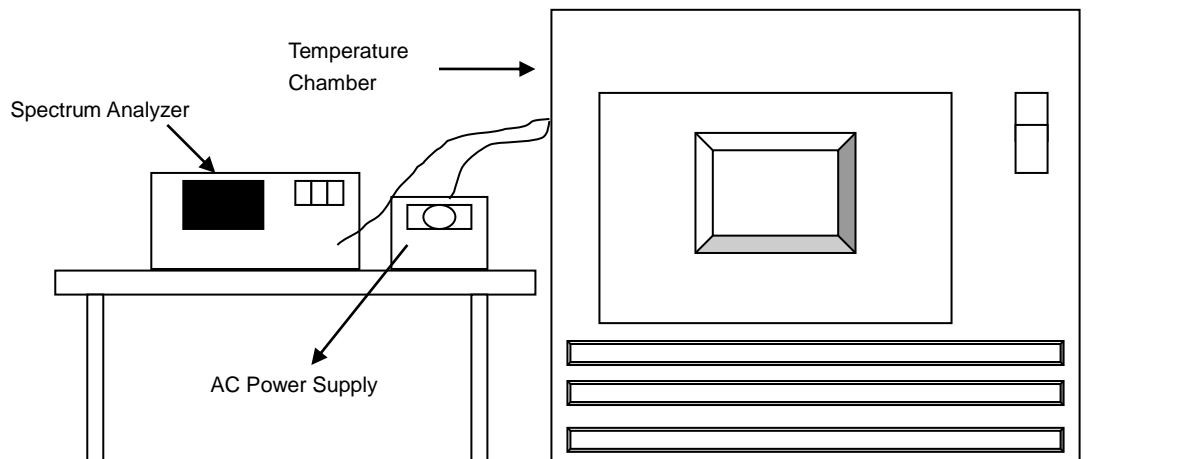

4.6.3 Test Instruments

Refer to section 4.1.2 to get information of above instrument.

4.6.4 Test Procedure

- The EUT was placed inside the environmental test chamber and powered by nominal AC voltage.
- Turn the EUT on and couple its output to a spectrum analyzer.
- Turn the EUT off and set the chamber to the highest temperature specified.
- Allow sufficient time (approximately 30 min) for the temperature of the chamber to stabilize, turn the EUT on and measure the operating frequency after 2, 5, and 10 Minutes.
- Repeat step (d) with the temperature chamber set to the next desired temperature until measurements down to the lowest specified temperature have been completed.
- The test chamber was allowed to stabilize at +20 degree C for a minimum of 30 Minutes. The supply voltage was then adjusted on the EUT from 85% to 115% and the frequency record.

4.6.5 Deviation from Test Standard

No deviation.

4.6.6 EUT Operating Condition

Set the EUT transmit at un-modulation mode to test frequency stability.

4.6.7 Test Results

Frequency Stability Versus Temp.									
Operating Frequency: 5180 MHz									
TEMP. (°C)	Power Supply (Vac)	0 Minute		2 Minutes		5 Minutes		10 Minutes	
		Measured Frequency (MHz)	Pass/Fail	Measured Frequency (MHz)	Pass/Fail	Measured Frequency (MHz)	Pass/Fail	Measured Frequency (MHz)	Pass/Fail
40	120	5180.0106	PASS	5180.0099	PASS	5180.0132	PASS	5180.0137	PASS
30	120	5179.9944	PASS	5179.9964	PASS	5179.9965	PASS	5179.9933	PASS
20	120	5180.0135	PASS	5180.0141	PASS	5180.0155	PASS	5180.0127	PASS
10	120	5179.9913	PASS	5179.993	PASS	5179.9947	PASS	5179.992	PASS
0	120	5180.026	PASS	5180.0253	PASS	5180.0263	PASS	5180.0252	PASS

Frequency Stability Versus Voltage									
Operating Frequency: 5180 MHz									
TEMP. (°C)	Power Supply (Vac)	0 Minute		2 Minutes		5 Minutes		10 Minutes	
		Measured Frequency (MHz)	Pass/Fail	Measured Frequency (MHz)	Pass/Fail	Measured Frequency (MHz)	Pass/Fail	Measured Frequency (MHz)	Pass/Fail
20	138	5179.9917	PASS	5179.994	PASS	5179.9945	PASS	5179.9926	PASS
	120	5179.9913	PASS	5179.993	PASS	5179.9947	PASS	5179.992	PASS
	102	5179.9914	PASS	5179.9921	PASS	5179.9954	PASS	5179.993	PASS

4.7 6dB Bandwidth Measurement

4.7.1 Limits of 6dB Bandwidth Measurement

The minimum of 6dB Bandwidth Measurement is 0.5MHz.

4.7.2 Test Setup

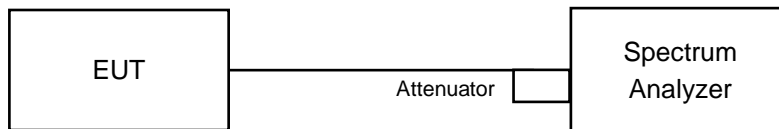

4.7.3 Test Instruments

Refer to section 4.1.2 to get information of above instrument.

4.7.4 Test Procedure

MEASUREMENT PROCEDURE REF

- Set resolution bandwidth (RBW) = 100kHz
- Set the video bandwidth (VBW) $\geq 3 \times$ RBW, Detector = Peak.
- Trace mode = max hold.
- Sweep = auto couple.
- Measure the maximum width of the emission that is constrained by the frequencies associated with the two amplitude points (upper and lower) that are attenuated by 6 dB relative to the maximum level measured in the fundamental emission.

4.7.5 Deviation from Test Standard

No deviation.

4.7.6 EUT Operating Condition

The software provided by client to enable the EUT under transmission condition continuously at lowest, middle and highest channel frequencies individually.

4.7.7 Test Results

CDD Mode

802.11a

Channel	Frequency (MHz)	6dB Bandwidth (MHz)		Minimum Limit (MHz)	Pass / Fail
		Chain 0	Chain 1		
149	5745	16.38	15.82	0.5	Pass
157	5785	16.38	15.83	0.5	Pass
165	5825	16.4	16.16	0.5	Pass

802.11ac (VHT20)

Channel	Frequency (MHz)	6dB Bandwidth (MHz)		Minimum Limit (MHz)	Pass / Fail
		Chain 0	Chain 1		
149	5745	17.62	16.36	0.5	Pass
157	5785	17.64	17.58	0.5	Pass
165	5825	17.62	17.63	0.5	Pass

802.11ac (VHT40)

Channel	Frequency (MHz)	6dB Bandwidth (MHz)		Minimum Limit (MHz)	Pass / Fail
		Chain 0	Chain 1		
151	5755	35.32	35.18	0.5	Pass
159	5795	35.2	35.21	0.5	Pass

802.11ac (VHT80)

Channel	Frequency (MHz)	6dB Bandwidth (MHz)		Minimum Limit (MHz)	Pass / Fail
		Chain 0	Chain 1		
155	5775	76.05	75.41	0.5	Pass

Spectrum Plot of Worst Value

802.11a_Chain 1 / CH149

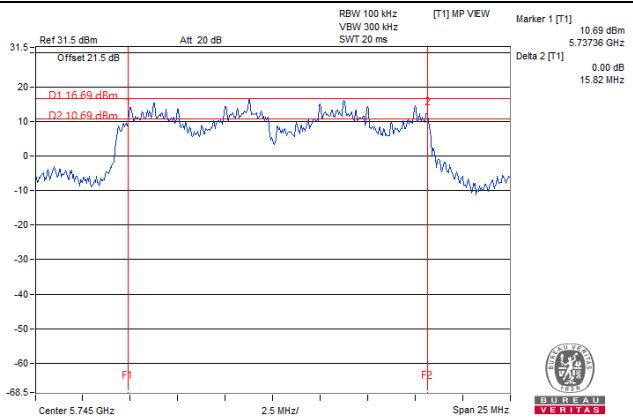

802.11ac (VHT20)_Chain 1 / CH149

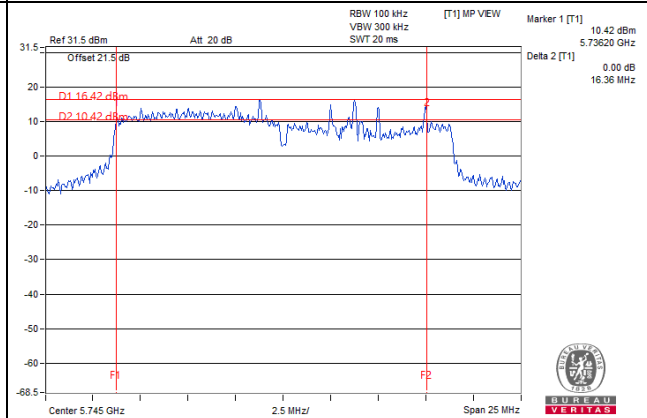

802.11ac (VHT40)_Chain 1 / CH151

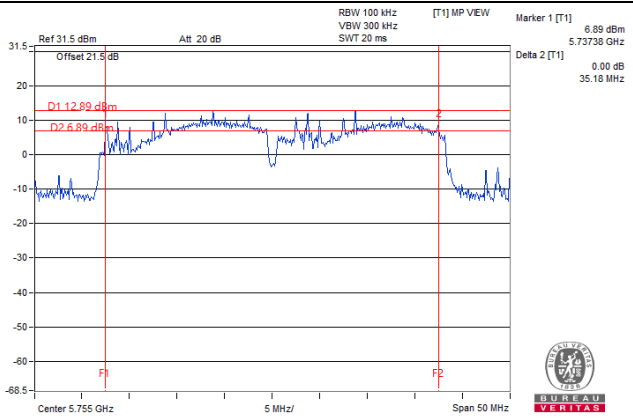

802.11ac (VHT80)_Chain 1 / CH155

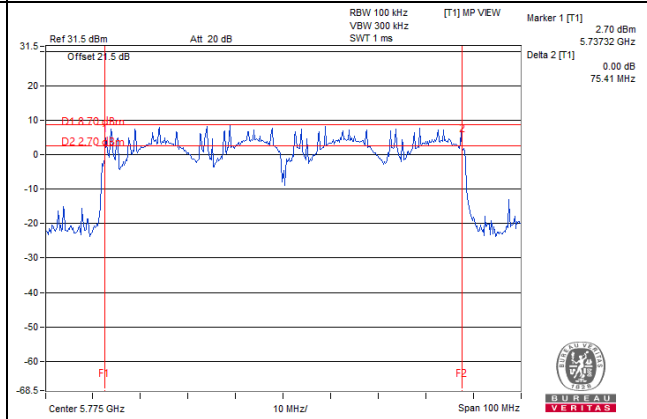

5 Pictures of Test Arrangements

Please refer to the attached file (Test Setup Photo).

Annex A- Radiated Out of Band Emission (OOBE) Measurement (For U-NII-3 band)

802.11a

CH 149 5745 MHz

Horizontal

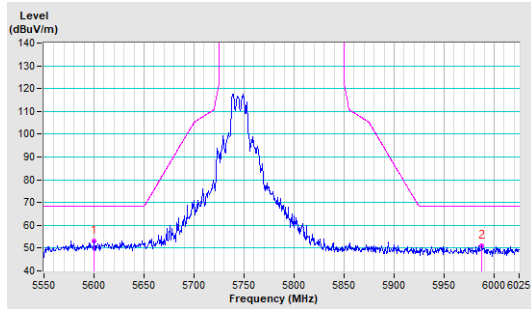

Vertical

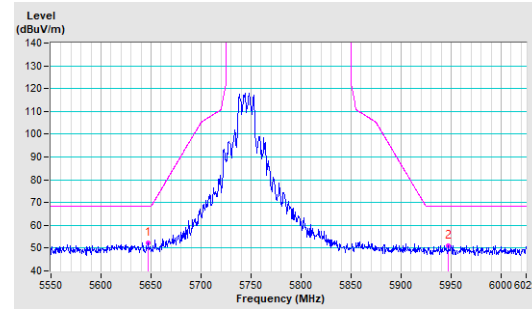

CH 157 5785 MHz

Horizontal

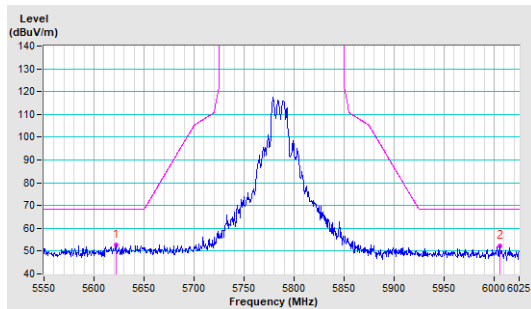

Vertical

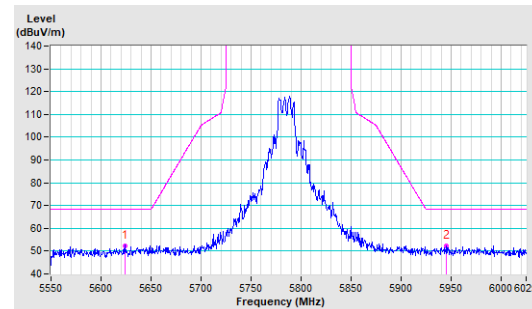

CH 165 5825 MHz

Horizontal

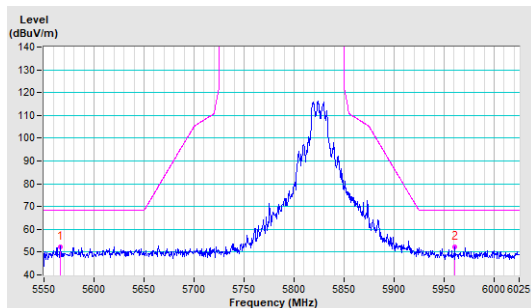

Vertical

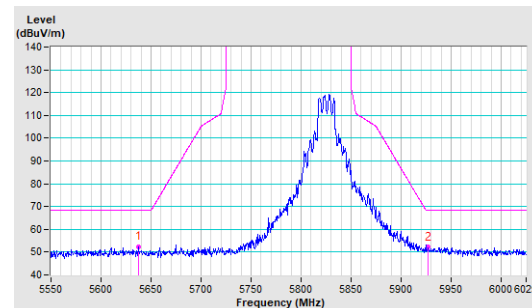

802.11ac (VHT20)

CH 149 5745 MHz

Horizontal

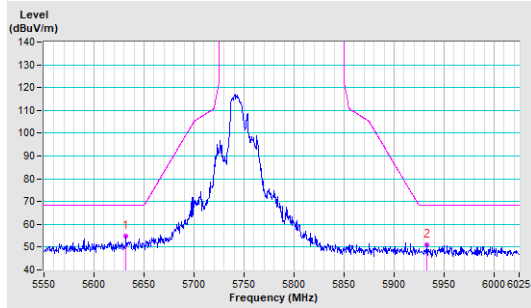

Vertical

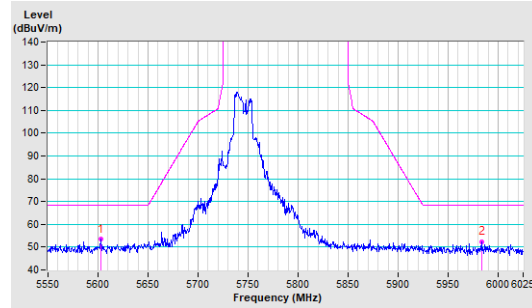

CH 157 5785 MHz

Horizontal

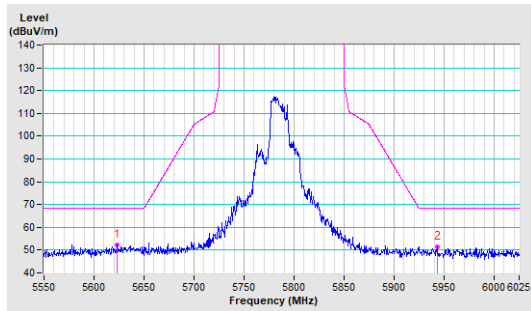

Vertical

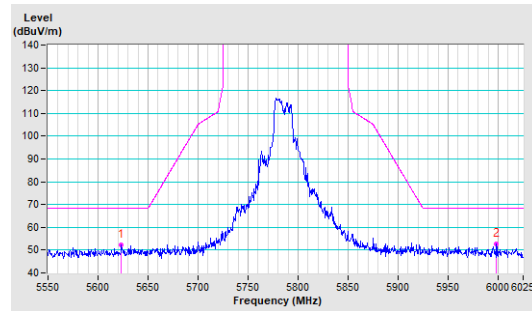

CH 165 5825 MHz

Horizontal

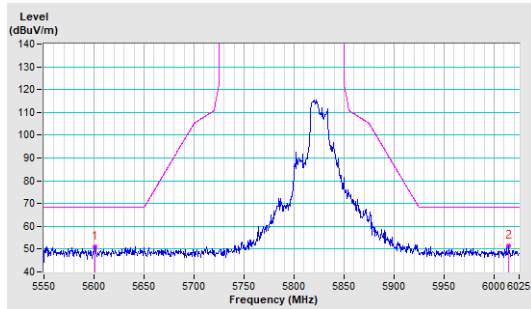

Vertical

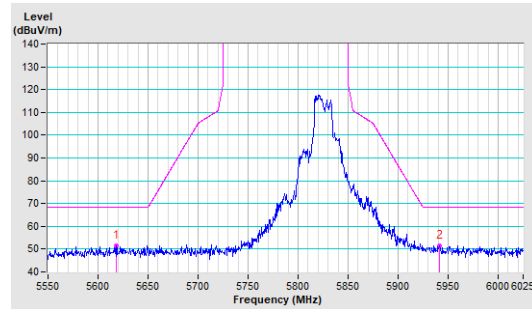

802.11ac (VHT40)

CH 151 5755 MHz

Horizontal

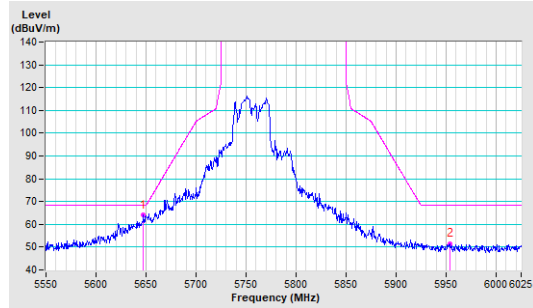

Vertical

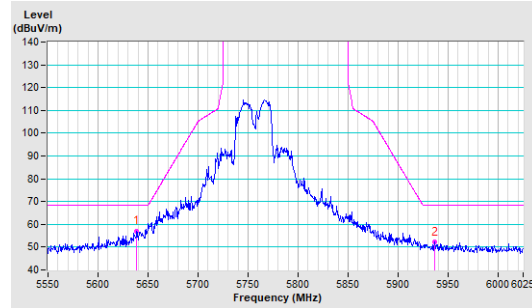

CH 159 5795 MHz

Horizontal

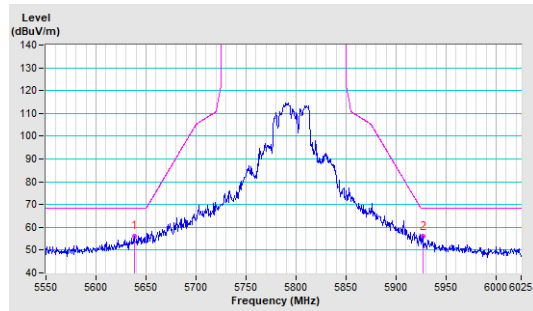

Vertical

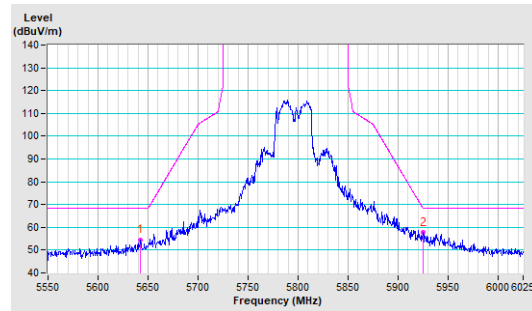

802.11ac (VHT80)

CH 155 5775 MHz

Horizontal

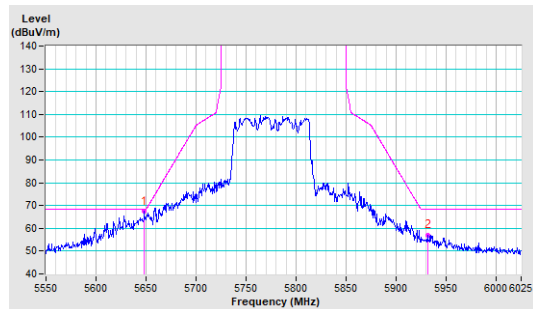

Vertical

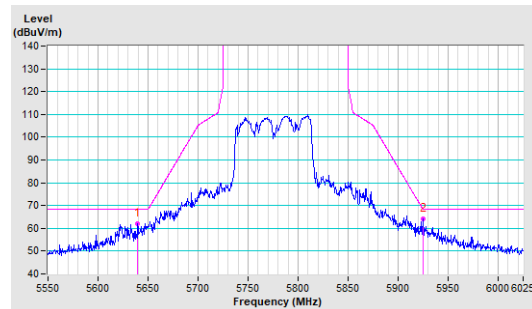

Annex B- Band-edge measurement (For U-NII-1 band)

802.11a

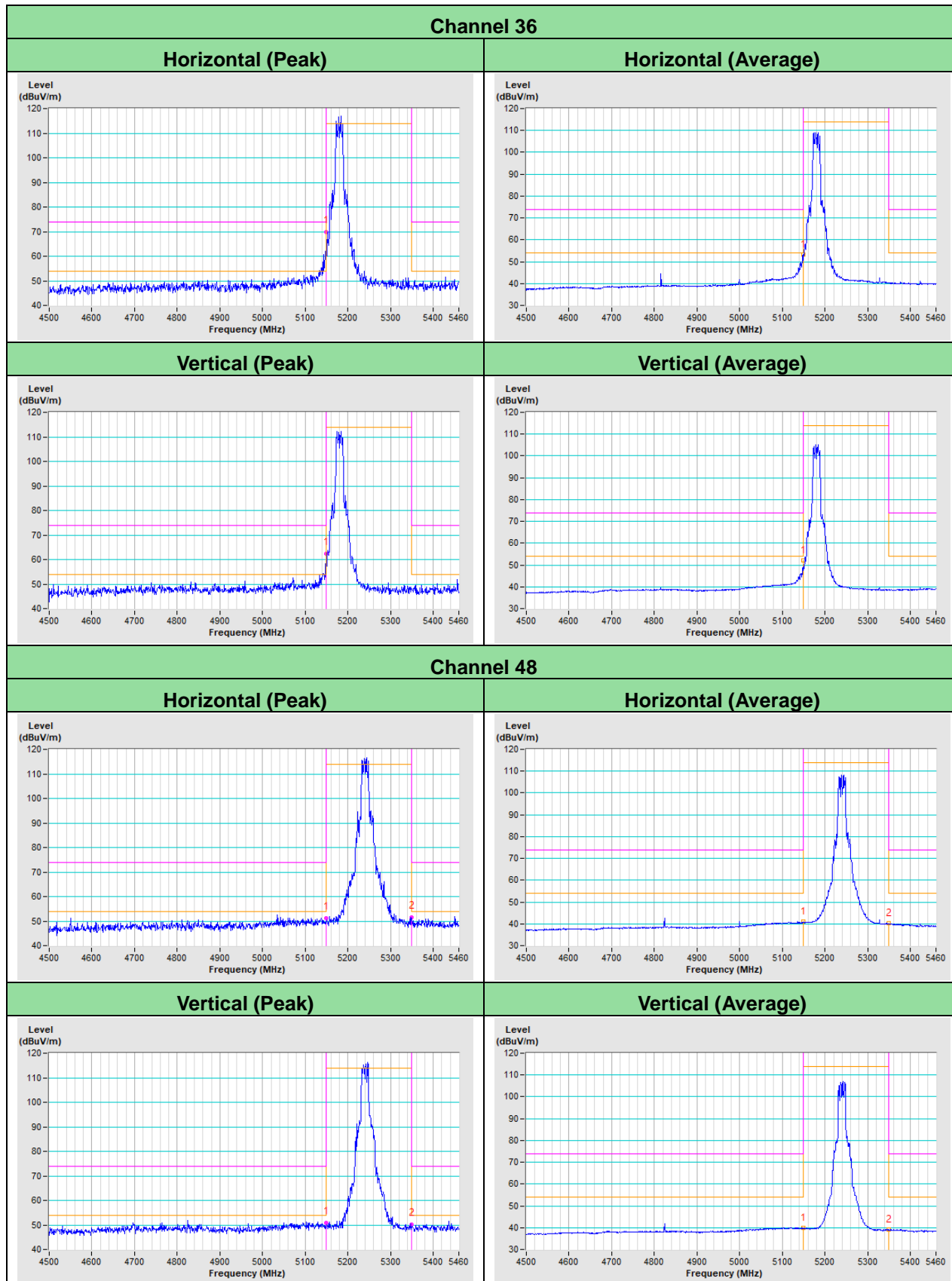

802.11ac (VHT20)

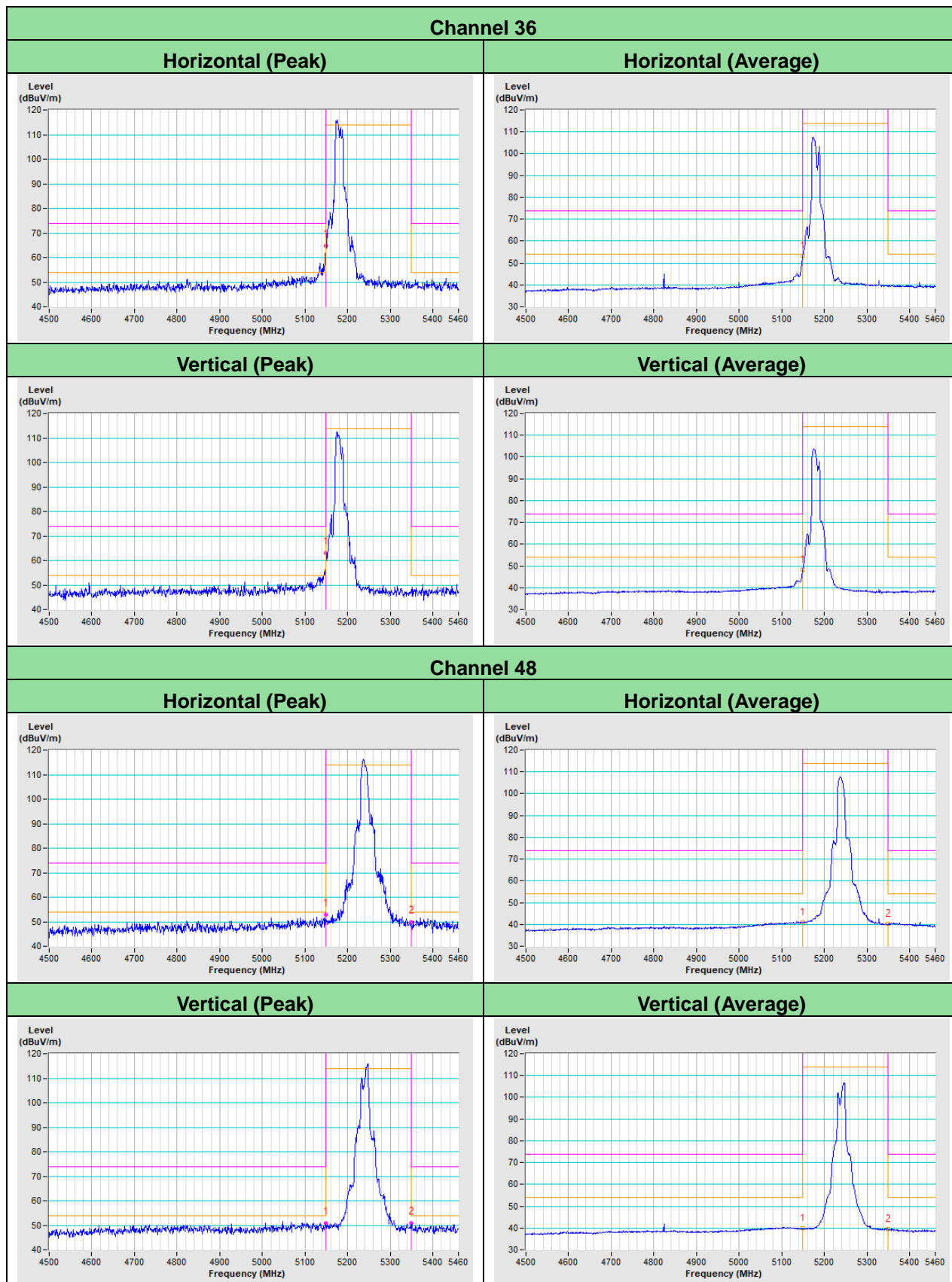

802.11ac (VHT40)

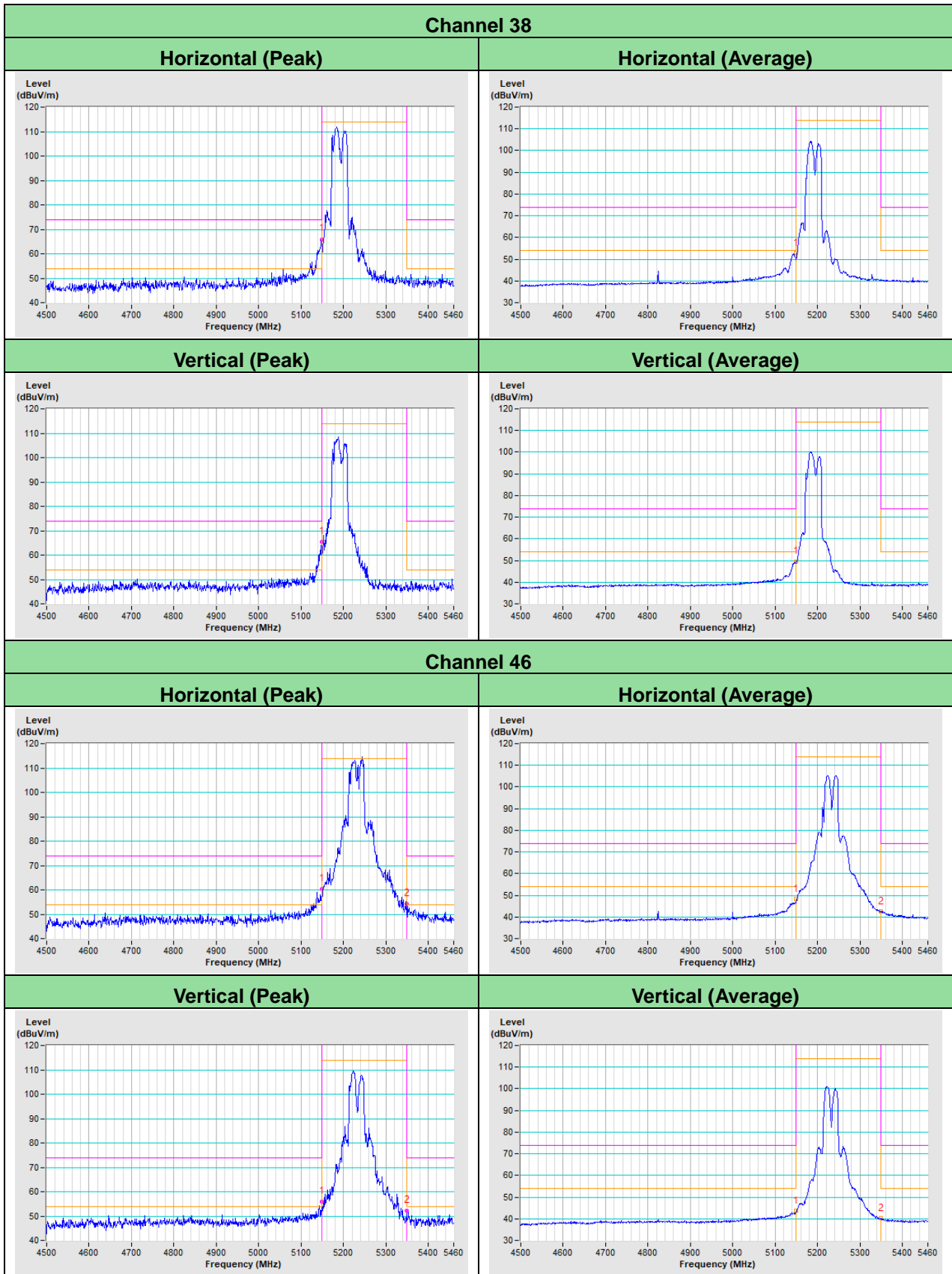

802.11ac (VHT80)

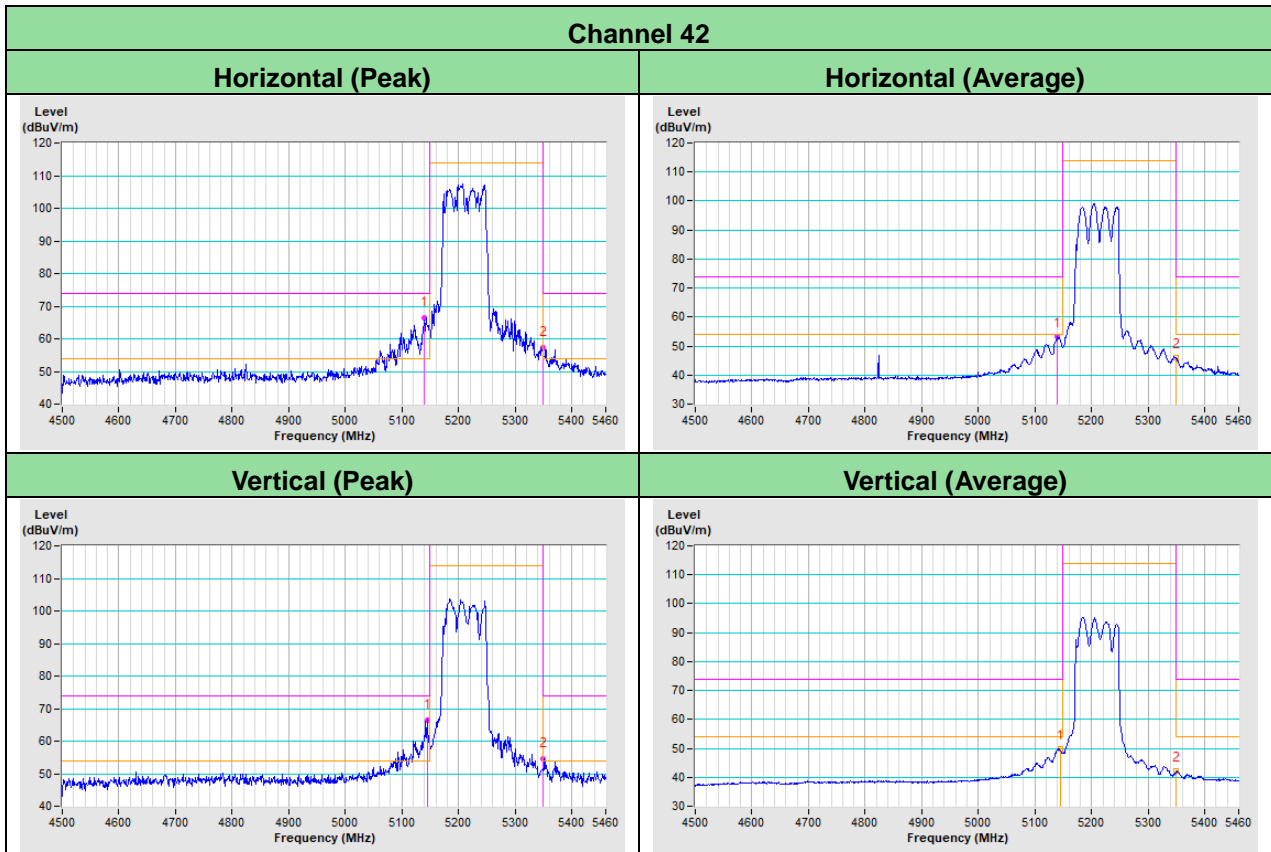

Appendix – Information of the Testing Laboratories

We, Bureau Veritas Consumer Products Services (H.K.) Ltd., Taoyuan Branch, were founded in 1988 to provide our best service in EMC, Radio, Telecom and Safety consultation. Our laboratories are FCC recognized accredited test firms and accredited according to ISO/IEC 17025.

If you have any comments, please feel free to contact us at the following:

Lin Kou EMC/RF Lab

Tel: 886-2-26052180

Fax: 886-2-26051924

Hsin Chu EMC/RF/Telecom Lab

Tel: 886-3-6668565

Fax: 886-3-6668323

Hwa Ya EMC/RF/Safety Lab

Tel: 886-3-3183232

Fax: 886-3-3270892

Email: service.adt@tw.bureauveritas.com

Web Site: www.bureauveritas-adt.com

The address and road map of all our labs can be found in our web site also.

--- END ---