

Prüfbericht-Nr.: Test report no.:	ULR-TC568822300000061F	Auftrags-Nr.: Order no.:	146696276 010	Seite 1 von 56 Page 1 of 56
Kunden-Referenz-Nr.: Client reference no.:	2133653	Auftragsdatum: Order date:	2022.07.01	
Auftraggeber: Client:	Grayshift LLC, 931 Monroe Dr NE, Suite A102-340, Atlanta Georgia United States, Phone: (833) 472-9539, Fax: (404) 420-2797			
Prüfgegenstand: Test item:	GrayKey	Serien-Nr.: serial no.:	Engineering Sample	
Bezeichnung.: Identification .:	GK.02			
Auftrags-Inhalt: Order content:	Testing and issue of Test Report with Grant Certificate			
Prüfgrundlage: Test specification:	FCC Part 15 Subpart E 15.407, 15.247, 15.207, 15.205 & 15.209 RSS247 Issue2 & RSS GEN Issue5			
Wareneingangsdatum: Date of sample receipt:	2022.07.06			
Prüfmuster-Nr Test sample no	A003294326-001 & A003294326-002			
Prüfzeitraum: Testing period:	2022.07.06 - 2022.07.11			
Ort der Prüfung: Place of testing:	Wireless laboratory, Bangalore			
Prüflaboratorium: Testing laboratory:	TÜV Rheinland (India) Pvt.Ltd., 27/B, 2nd Cross, Electronic City Phase1 Bangalore -560 100, India FCC Test site registration number: 496599 ISED Test site registration number: 3466E-1			
Prüfergebnis*: Test result*:	Pass			
geprüft von: tested by:	genehmigt von: authorized by:			
Datum: Date: 2022.07.15	 M.V.Naveen Kumar Engineer		Ausstellatum: Issue date: 2022.08.29	 Madhu K.N Senior Engineer
Stellung / Position:			Stellung / Position:	
Sonstiges / Other:	FCC ID: 2AV7EGK02 IC : 26020-GK02			
Zustand des Prüfgegenstandes bei Anlieferung: Condition of the test item at delivery:	Prüfmuster vollständig und unbeschädigt Test item complete and undamaged			
* Legende:	1 = sehr gut P(ass) = entspricht o.g. Prüfgrundlage(n)	2 = gut F(ail) = entspricht nicht o.g. Prüfgrundlage(n)	3 = befriedigend N/A = nicht anwendbar	4 = ausreichend N/T = nicht
* Legend:	1 = very good P(ass) = passed a.m. test specification(s)	2 = good F(ail) = failed a.m. test specification(s)	3 = satisfactory N/A = not applicable	4 = sufficient N/T = not tested
<p>Dieser Prüfbericht bezieht sich nur auf das o.g. Prüfmuster und darf ohne Genehmigung der Prüfstelle nicht auszugsweise vervielfältigt werden. Dieser Bericht berechtigt nicht zur Verwendung eines Prüfzeichens. <i>This test report only relates to the a. m. test sample. Without permission of the test center this test report is not permitted to be duplicated in extracts. This test report does not entitle to carry any test mark.</i></p>				

TEST SUMMARY

Test Item	Applicable Standard		Result
	FCC	ISED	
Emission Bandwidth	15.407 (a) & (e) 15.247 (a)(2)	RSS Gen Issue 5 Section 6.7 RSS 247 Issue 2 Section 6.2.4.1	*N/T
Frequency Stability	15.407 (g)	RSS Gen Issue 5 Section 8.11	*N/T
Maximum conducted output power	15.407 (a) & 15.247 b(3)	RSS 247 Issue 2 Section 6.2.1 & Section 6.2.4	Pass
Maximum Power spectral density	15.407 (a)	RSS 247 Issue 2 Section 6.2.1 & Section 6.2.4	*N/T
Dynamic Frequency Selection	15.407 (h)	RSS 247 Issue 2 Section 6.3	*N/T
Spurious Radiated Emissions & Restricted Bands of Operation	15.407 (b) / (15.205 & 15.209)	RSS 247 Issue 2 Section 6.2.1 & Section 6.2.4 RSS Gen Issue 5 Section 8.9 & 8.10	Pass
Conducted Spurious Emission on AC Power Lines	15.207	RSS Gen Issue 5 Section 8.8	Pass
Antenna Requirement	15.203	NA	Pass

Note:

NA: Not Applicable

*N/T: Not tested – These test cases are not tested, the product uses certified RF module

Sterling-LWB5+802.11b/g/n/ac module with Bluetooth 5.0 from Laird Connectivity., with

FCC ID: SQG-LWB5PLUS & IC : 3147A-LWB5PLUS. Issued by the International Certification Corp.

Product Category: Electronics Testing
Test Discipline : EMC Test Facility

Prüfbericht - Nr.:
Test Report No.:

ULR-TC568822300000061F

Seite 3 von 56
Page 3 of 56

REVISION HISTORY OF THIS REPORT

Report Number	Version	Description	Issue date
ULR-TC568822300000061F	01	Initial issue of report	2022.08.29

Table of Contents

1	GENERAL REMARKS	5
1.1	Attachments	5
2	TEST SITES	6
2.1	Testing Facilities.....	6
2.2	List of Test and Measurement Instruments.....	6
3	GENERAL PRODUCT INFORMATION.....	8
3.1	Product Function and Intended Use.....	8
3.2	Ratings and System Details of Equipment under Test	8
3.3	Measurement Uncertainty:	9
4	TEST SET-UP AND OPERATION MODE	10
4.1	Principle of Configuration Selection	10
4.2	UUT Operation and Software	10
4.3	Special Accessories and Auxiliary Equipment	10
4.4	Simultaneous Transmission	10
4.5	Countermeasures to achieve EMC Compliance	10
4.6	List of frequencies	11
4.7	Report Reference	11
5	Operational Description	12
6	TEST METHODOLOGY	13
6.1	Conducted Spurious Emission AC Power line Test.....	13
6.1.1	Test Setup Configuration	13
6.2	Radiated Emission Test	14
6.2.1	Test Setup Configuration	14
7	TEST RESULTS	16
7.1	Maximum Conducted Output Power	16
7.2	Spurious Radiated Emissions & Restricted Bands of Operation	24
7.3	Conducted Spurious Emission test on AC Power Line	53
8	LIST OF TABLES.....	56
9	Power level used for testing.....	56

1 GENERAL REMARKS

1.1 Attachments

All attachments are part of this test report and are issued in separate document

- 1: TEST SETUP PHOTOS
- 2: EUT EXTERNAL PHOTOS
- 3: EUT INTERNAL PHOTOS
- 4: FCC LABEL AND LABEL LOCATION
- 5: BLOCK DIAGRAM
- 6: SPECIFICATION OF EUT
- 7: SCHEMATIC DIAGRAM
- 8: BILL OF MATERIAL
- 9: USER MANUAL
- 10: MAXIMUM PERMISSIBLE EXPOSURE INFORMATION

2 TEST SITES

2.1 Testing Facilities

1. TÜV Rheinland (India) Pvt.Ltd.,
27/B, 2nd Cross,
ElectronicCityPhase1
Bangalore – 560 100,
India

2. TUV Rheinland (India) Pvt.Ltd.,
108 , Beside ISBR Business School,
Electronic city Phase I
Bangalore - 560 100.
India

Radiated Measurement site type :
Fully anechoic chamber (used for above 1 GHz
measurements)

Radiated Measurement site type :
Semi anechoic chamber (used for below 1 GHz
measurements)

2.2 List of Test and Measurement Instruments

Table 1: List of test and measurement instruments

Equipment	Manufacturer	Model Name	Serial Number	Firmware Versions	Calibration Due Date	Periodicity	Test Facility
EMI Receiver	Rohde & Schwarz	ESW 44	101732	4.73 SP5	19.08.2022	Yearly	Radiated Spurious Emission
EMI Receiver	Rohde & Schwarz	ESW 44	101733	1.72SP1	12.02.2023	Yearly	
Active loop antenna	Frankonia	LAX-18	LAX-10-800	-	31.01.2023	Yearly	
Balloon and Biconical Antenna	Schwarzbeck	VHBB-9124 / BBA-9106	1028	-	03.02.2023	Yearly	
Log - Periodical Antenna	Schwarzbeck	VUSLP-9111B	9111B-111	-	04.02.2023	Yearly	
Horn Antenna	Schwarzbeck	BBHA 9120 D	9120D-1944	-	03.09.2022	Yearly	
Horn Antenna	Schwarzbeck	BBHA 9170	BBHA 9170-0904	-	06.09.2022	Yearly	
Semi Anechoic Chamber	Frankonia	-	-	-	-	-	
Fully Anechoic Chamber	Albatross	-	-	-	-	-	
Spectrum Analyser	Agilent Technologies	E4407B	US41192772	A.14.06	15.12.2022	Yearly	Antenna-Port Conducted test
EMI Receiver	Rohde & Schwarz	ESR7	101133	3.48 SP3	14.07.2022	Yearly	Conducted AC Power line Test
Pulse Limiter	Rohde & Schwarz	ESH3-Z2	100811	-	29.07.2022	Yearly	
LISN	Rohde & Schwarz	ENV216	100022	-	07.10.2022	Yearly	

Prüfbericht - Nr.:
Test Report No.:

ULR-TC568822300000061F

Seite 7 von 56
Page 7 of 56

Table 2: Instrument application Software versions

SL. No.	Test Type	Application software	Version
1	Radiated spurious emission measurement in 10mtr-SAC	BAT EMC	3.20.0.17
2	Radiated spurious emission measurement in 3mtr-FAC	EMC 32	10.60.00

3 GENERAL PRODUCT INFORMATION

3.1 Product Function and Intended Use

Grayshift's GrayKey solution delivers robust access and extraction capabilities for locked and encrypted mobile devices. GrayKey supports lawful, same-day access to the latest iOS and Android devices, typically extracting and accessing multiple data types, to expedite critical investigations.

3.2 Ratings and System Details of Equipment under Test

Table 3: Ratings and System Details as declared by the Client*

Radio Protocol	WI-FI 5GHz	
Operating Frequency Range	UNII-1 _ 5150MHz to 5250MHz UNII-3 _ 5725MHz to 5825MHz	
No. of Channels	(Refer Table 5: List of Wi-Fi center Frequencies)	
Channel Spacing	20MHz,40MHz,80MHz	
Modulation	OFDM-BPSK, QPSK, 16-QAM, 64-QAM, and 256-QAM modulation	
Power level setting used	Refer Clause 9	
Maximum Measured Average Power (dBm)	16.87dBm @ UNII-1(5240MHz a-mode 6Mbps)	
Number of antennas	1	
Antenna Gain	4dBi	
Antenna Type	Chip Antenna	
Supply Voltage to Product	110VAC 60Hz through Adapter & 3.7V of Li-Po Battery	
Environmental Conditions	Storage	0° C to 55° C
	Operating	0° C to 55° C
EUT Dimension(L x Wx H)	200 x 135 x 60 mm	

***Disclaimer:** The information/data is supplied by the client and the same is considered to arrive at the final value. Any changes made apart from the specified specification, can directly impact on the tests results. Refer the products user manual for more details.

Note: Product **GrayKey** has multiple protocols. All the supported wireless protocols and their respective test results are issued in separate test reports, refer clause 4.7 Report references

3.3 Measurement Uncertainty:

Reported uncertainties represent expanded uncertainties expressed at approximately the 95% confidence level using a coverage factor of $k = 2$

Table 4: Measurement Uncertainty

Parameter	Uncertainty
Occupied Channel Bandwidth	±5 %
RF output power, conducted	±1.5 dB
Power Spectral Density, conducted	±3 dB
Unwanted Emissions, conducted	±3 dB
SAC, radiated measurement	±6 dB
FAC, radiated measurement	±6 dB
Temperature	±3 °C
Supply Voltages	±3 %
Time	±5 %

Note: The listed uncertainties are the worst case uncertainty for the entire range of measurements and are for the reporting purpose only and are not used in determining the PASS/FAIL of the results.

4 TEST SET-UP AND OPERATION MODE

4.1 Principle of Configuration Selection

Transmission was enabled with highest possible duty cycle on low, mid and high channels.

4.2 UUT Operation and Software

Hardware Version : 2.0

Software version : 1.4.0

4.3 Special Accessories and Auxiliary Equipment

Model Name	Model Number	Power Adapter Ratings
FSP	FSP045-D3MR3	AC Input : 100V-240V ~,1.2A,50-60Hz DC Output: 5.0V/9.0V/12.0V/15.0V—3.0A 20.0V—2.25A of 45W
Li-Po Battery	-	3.7V , 5000mAH

4.4 Simultaneous Transmission

This product doesn't Support Simultaneous operation

4.5 Countermeasures to achieve EMC Compliance

- None

4.6 List of frequencies

Frequency Band	Channel No.	Frequency (MHz)
5150–5250 MHz	36	5180
	38	5190
	40	5200
	42	5210
	46	5230
	48	5240
5725-5825 MHz	149	5745
	151	5755
	155	5775
	157	5785
	159	5795
	165	5825

Table 5: List of Wi-Fi center Frequencies

Channel used for Wi-Fi Testing

Channel Bandwidth (20MHz)	Channel Bandwidth (40MHz)	Channel Bandwidth (80MHz)
5180	5190	5210
5200	5230	5775
5240	5755	-
5745	5795	-
5785	-	-
5825	-	-

Note:

TUV Sample Identification number : A003294326-001 – Radiated test Sample
A003294326-002 – Conducted test Sample

4.7 Report Reference

Note: Product **GrayKey** has multiple protocols. All the supported wireless protocols and their respective test results are issued in separate test reports, following table lists the report numbers.

Radio Protocol	Report Number
RF test report for Wi-Fi (2.4GHz)	ULR-TC56882230000060F
RF test report for Wi-Fi (5GHz) – (This report)	ULR-TC56882230000061F

5 Operational Description

The Grakey solution is required to network and licence configured first as described in the user manual. After that the end device need to be connected with Graykey for access and extraction purpose. Here Graykey will perform BFU and AFU extractions and generate full extraction report.

6 TEST METHODOLOGY

6.1 Conducted Spurious Emission AC Power line Test

Measured levels of ac power-line conducted emission across the 50Ω LISN port (to which the EUT is connected). All emission voltage and current measurements shall be made on each current-carrying conductor at the plug end of the EUT power cord by the use of mating plugs and receptacles on the LISN, if used. Equipment shall be tested with power cords that are normally supplied or recommended by the manufacturer and that have electrical and shielding characteristics that are the same as those cords normally supplied or recommended by the manufacturer.

The device is placed on the test table, raised 80cm above the reference ground plane. The vertical conducting plane is located 40cm to the rear of the device. AC Conducted emission measurement is made over frequency range from 150kHz to 30MHz, this measurement was performed with EUT powered by 2 methods and both method are tested individually, one with an AC adaptor with 110V AC 60Hz supply and second with Wireless charger with supply 110V AC 60Hz.

6.1.1 Test Setup Configuration

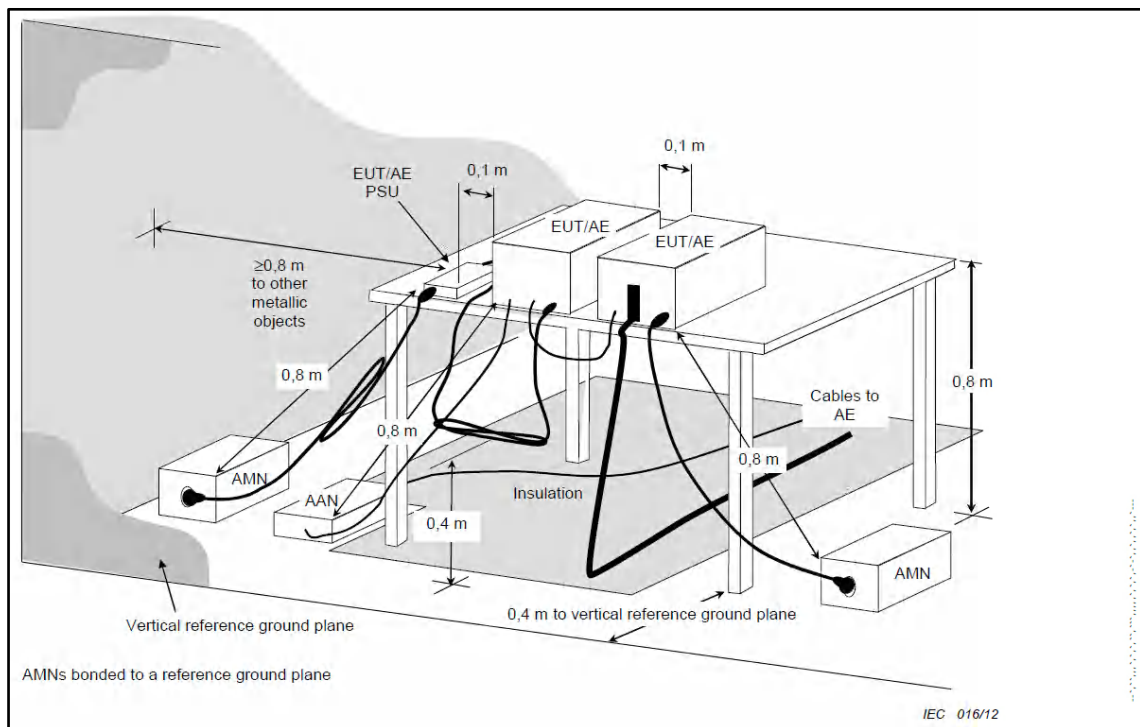

6.2 Radiated Emission Test

The radiated emission measurement was performed according to the procedures in ANSI C63.10-2013. The equipment under test (EUT) was placed at the middle of the 80 cm high turntable for below 1 GHz & 1.5 m height for above 1 GHz measurement, and the EUT is 3 meters far from the measuring antenna. The turntable was rotated 360° for obtaining the maximum emission. The height of the measuring antennas was scanned between 1 m and 4 m, and the antenna rotated to repeat the measurements for both the horizontal and vertical antenna polarizations. Repeat the measurement steps until the maximum emissions were obtained. The measurement above 1000 MHz was performed by horn antenna, The measurement below 30 MHz was performed by loop antenna, Measurement from 30 MHz to 200 MHz was performed by Baloon and Biconical Antenna, and mesurement from 200 MHz to 1 GHz was performed by Log-Periodic Antenna.

The EUT was rotated around the X-, Y-, and Z-Axis and the results from worst case axis are recorded

6.2.1 Test Setup Configuration

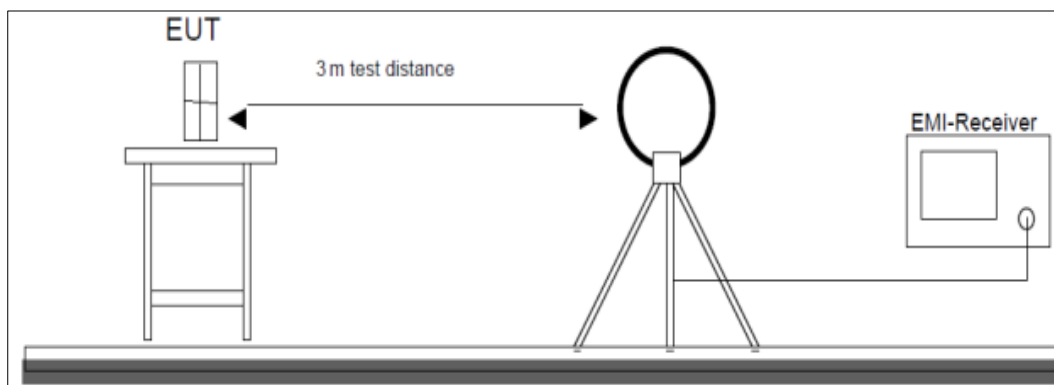

Figure 1: Frequency Range 9 kHz- 30 MHz

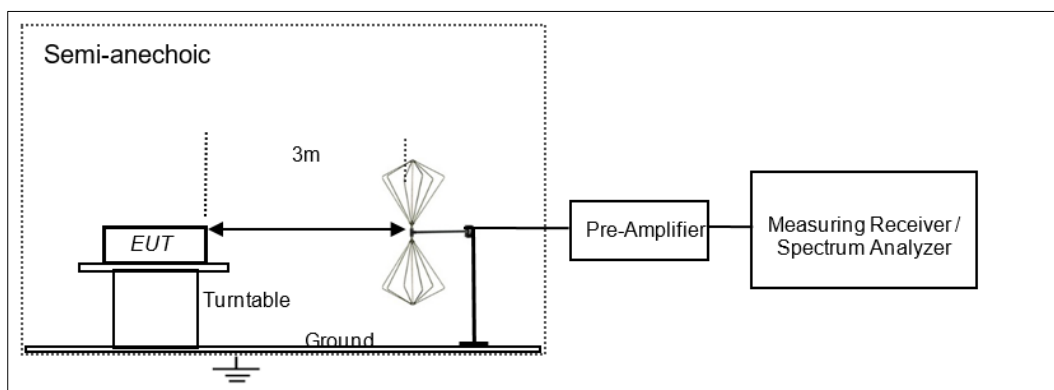

Figure 2: Frequency Range 30 MHz – 200 MHz

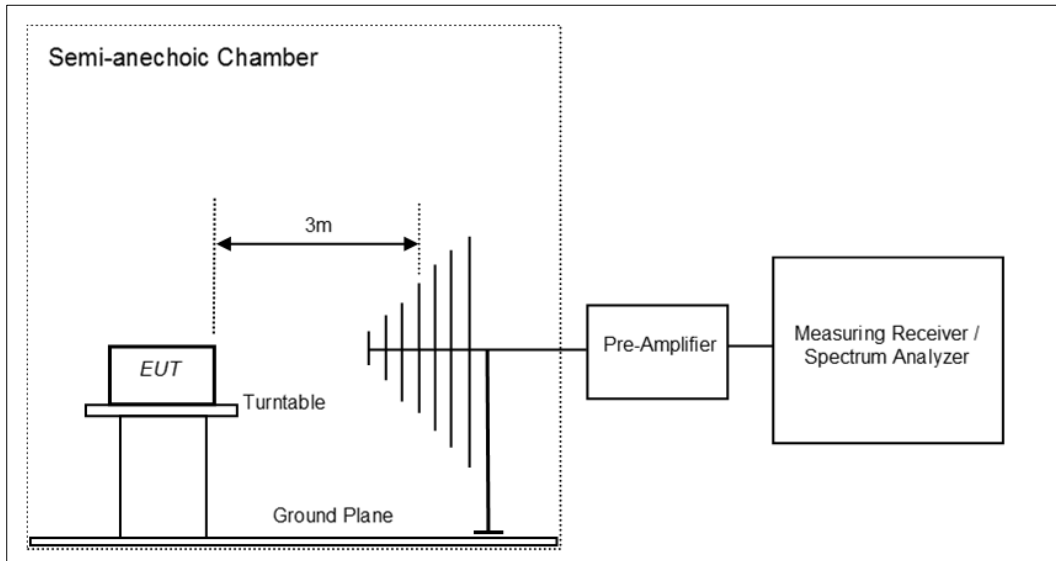

Figure 3: Frequency Range 200 MHz - 1GHz

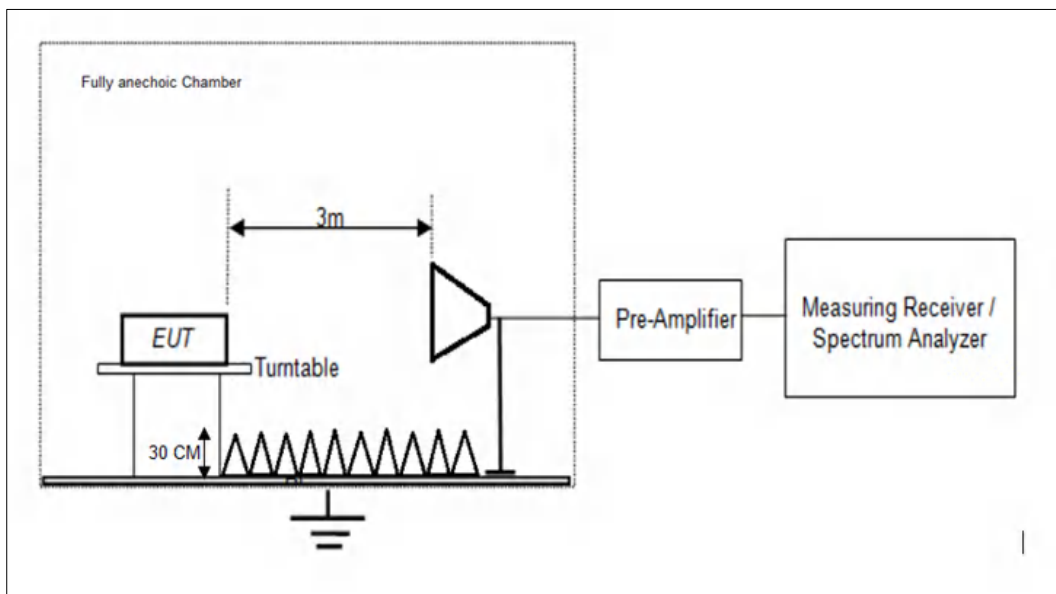

Figure 4: Frequency Range above 1 GHz

7 TEST RESULTS

7.1 Maximum Conducted Output Power

Result

Pass

Test Specification	FCC part 15 Subpart C 15.407 (a)/ 15.247 b(3) RSS 247 Issue 2 Clause 6.2.1.1 & 6.2.4.1
Test Method	Subclause 12.3.2.6 of ANSI C63.10
Measurement Bandwidth	1MHz
Detector	Average sample detector mode
Port of testing	Antenna port

Test Method

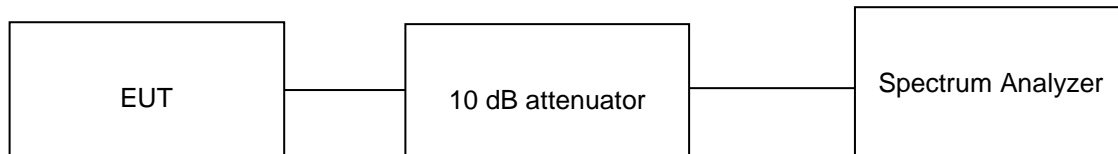

The following procedure shall be used (trace averaging across on and off times of the EUT transmissions, followed by duty cycle correction):

1. Set center frequency to the nominal EUT channel center frequency
2. Set span to encompass the EBW (or, alternatively, the entire 99% occupied bandwidth) of the signal.
3. Set RBW = 1MHz
4. Set VBW $\geq 3 \times$ RBW
5. Number of points in sweep $\geq 2 \times$ span / RBW. (This ensures that bin-to-bin spacing is \leq RBW/2, so that narrowband signals are not lost between frequency bins.)
6. Sweep time \leq [(number of points in sweep) \times T], Where T is Transmission duration
7. Detector = power averaging (rms)
8. Do not use sweep triggering. Allow the sweep to "free run."
9. Trace mode = maxhold
10. Allow max hold to run for at least 60 s or longer as needed to allow the trace to stabilize.
11. Compute power by integrating the spectrum across the 26 dB EBW or 99% OBW of the signal using the instrument's band power measurement function with band limits set equal to the EBW or OBW band edges. If the instrument does not have a band power function, then sum the spectrum levels (in power units) at 1 MHz intervals extending across the 26 dB EBW of the spectrum.

Prüfbericht - Nr.:
Test Report No.:

ULR-TC568822300000061F

Seite 17 von 56
Page 17 of 56

Test Condition:

Normal Test Condition:

Temperature (Norm) = + 22.6 °C Voltage = 110VAC 60Hz through Adapter Relative humidity: 62 %

KDB Guidelines applied:

Measurements were made as per section E (2) sub-section (d) in KDB 789033 D02 General UNII Test Procedures New Rules v02r01

Test results:

Note:

- All the losses are included during measurement and final values are mentioned in the test report
10 dB attenuator + 0.6 dB Cable loss = 10.6 dB total offset
- This product do not support additional beamforming gain / directional gain, it uses single antenna and hence directional gain of the single antenna is (4 dBi)

Modulation: 802.11a

Mode	BW	Data rate	Channel frequency (MHz)	Measured Average Power (dBm)	Final e.i.r.p (dBm)	FCC Limit (dBm)	ISED Limit (dBm)
a	20MHz	6Mbps	5180	10.20	14.20	30.00	23.00
			5200	12.36	16.36	30.00	23.00
			5240	12.87	16.87	30.00	23.00
			5745	12.43	16.43	30.00	30.00
			5785	12.46	16.46	30.00	30.00
			5825	12.15	16.15	30.00	30.00

Test plots:

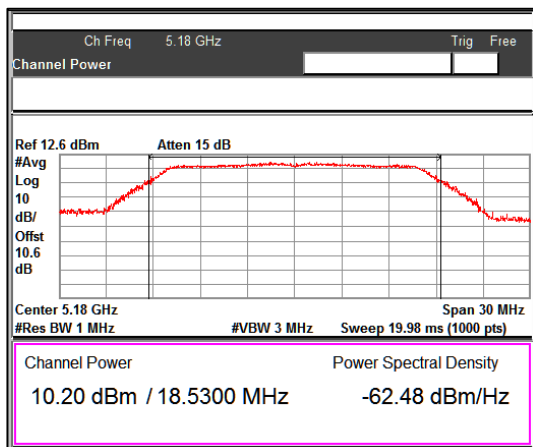

Channel frequency: 5180MHz

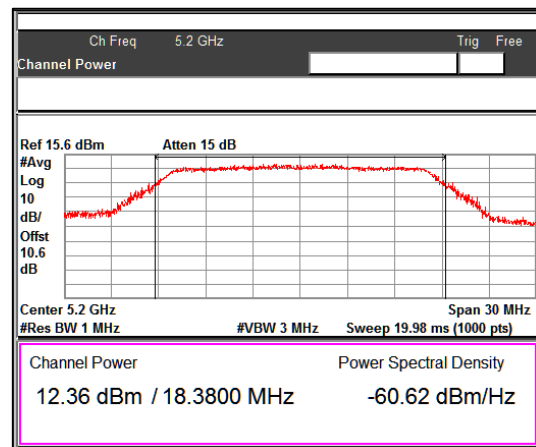

Channel frequency: 5200MHz

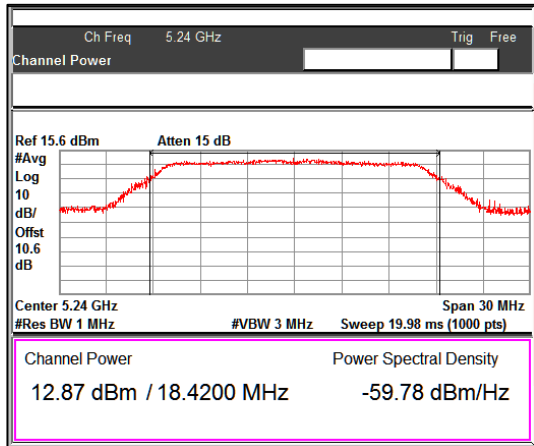

Channel frequency: 5240MHz

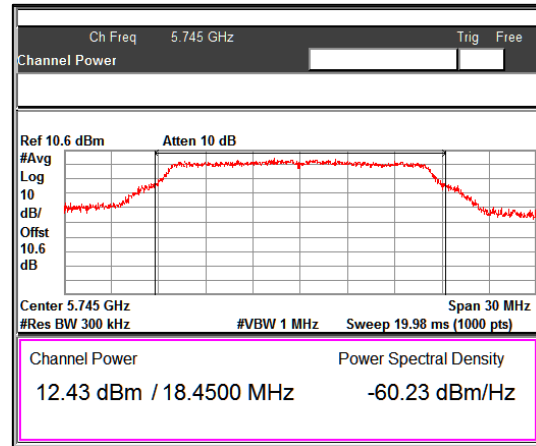

Channel frequency: 5745MHz

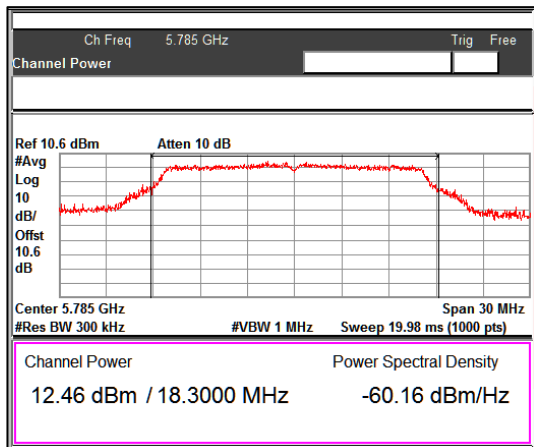

Channel frequency: 5785MHz

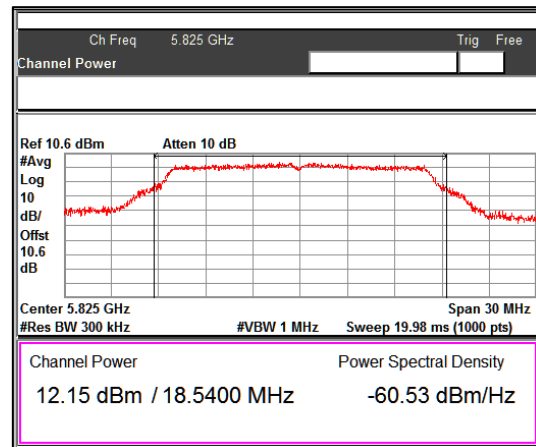

Channel frequency: 5825MHz

Modulation: 802.11n HT20

Mode	BW	Data rate	Channel frequency (MHz)	Measured Average Power	Measured e.i.r.p (dBm)	FCC Limit (dBm)	ISED Limit (dBm)
n	20MHz	MCS0	5180	9.49	13.49	30.00	23.00
			5200	12.22	16.22	30.00	23.00
			5240	12.44	16.44	30.00	23.00
			5745	12.52	16.52	30.00	30.00
			5785	12.76	16.76	30.00	30.00
			5825	12.53	16.53	30.00	30.00

Test Plots:

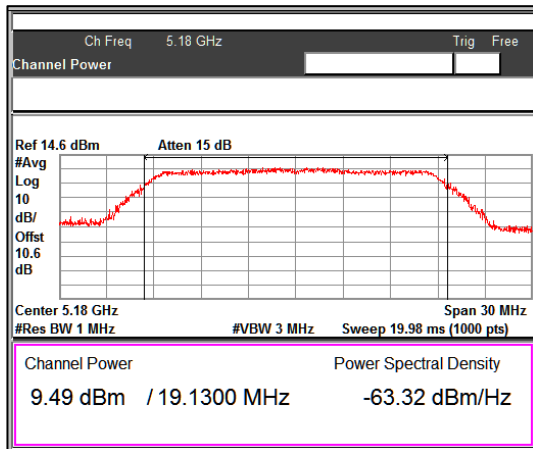

Channel frequency: 5180MHz

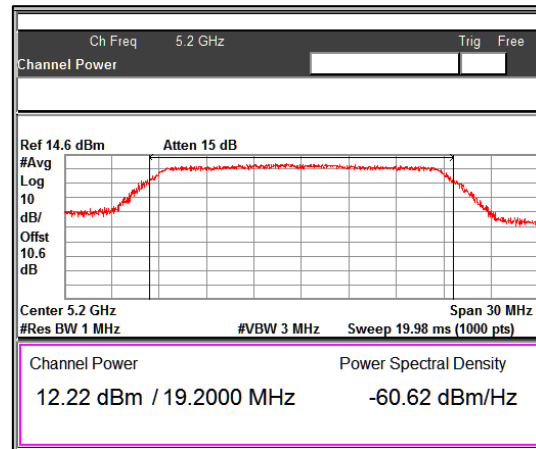

Channel frequency: 5200MHz

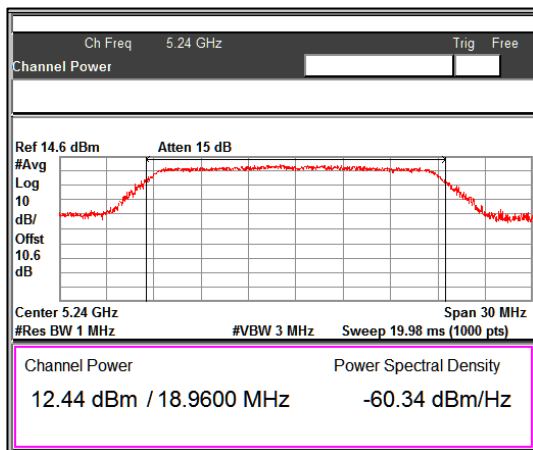

Channel frequency: 5240MHz

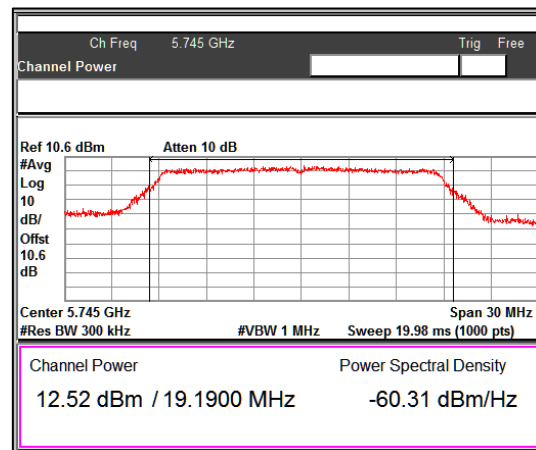

Channel frequency: 5745MHz

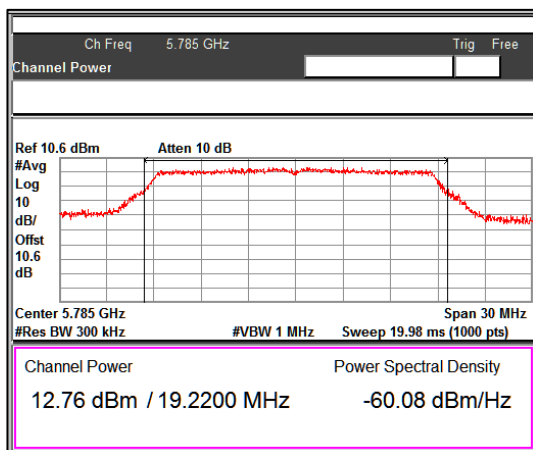

Channel frequency: 5785MHz

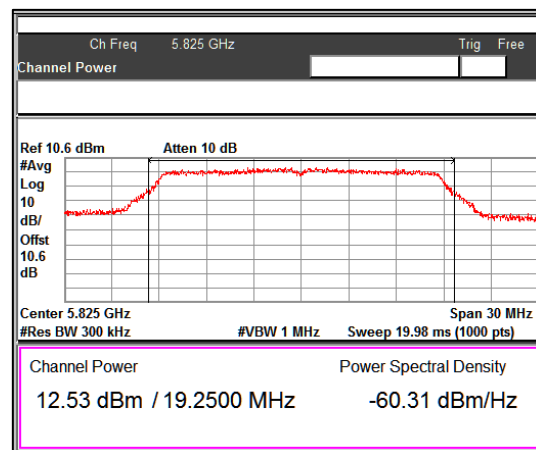

Channel frequency: 5825MHz

Modulation: 802.11n HT40

Mode	BW	Data rate	Channel frequency (MHz)	Measured Average Power	Measured e.i.r.p (dBm)	FCC Limit (dBm)	ISED Limit (dBm)
n	40MHz	MCS0	5190	7.07	11.07	30.00	23.00
			5230	10.11	14.11	30.00	23.00
			5755	8.77	12.77	30.00	30.00
			5795	8.85	12.85	30.00	30.00

Test Plots:

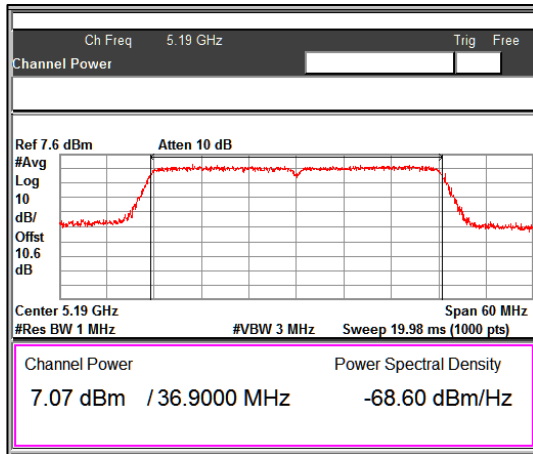

Channel frequency: 5190MHz

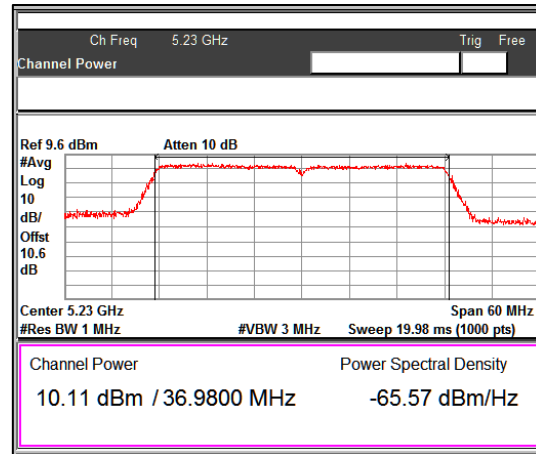

Channel frequency: 5230MHz

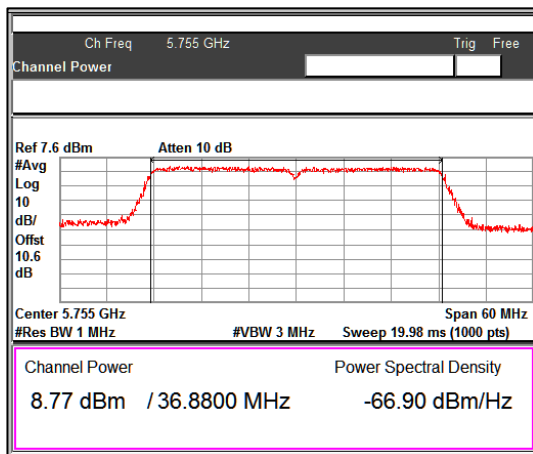

Channel frequency: 5755MHz

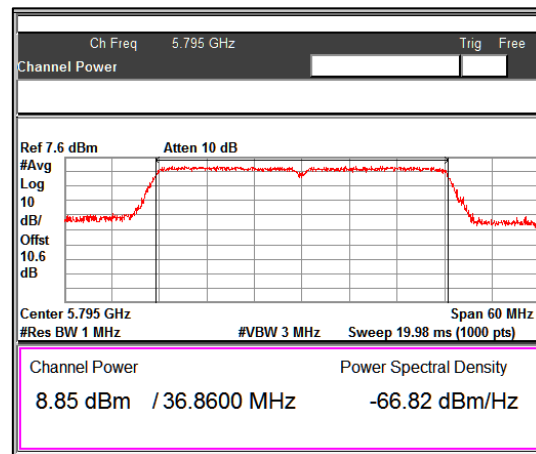

Channel frequency: 5795MHz

Modulation: 802.11ac VHT20

Mode	BW	Data rate	Channel frequency (MHz)	Measured Average Power	Measured e.i.r.p (dBm)	FCC Limit (dBm)	ISED Limit (dBm)
ac	20MHz	MCS0	5180	9.45	13.45	30.00	23.00
			5200	11.99	15.99	30.00	23.00
			5240	12.59	16.59	30.00	23.00
			5745	12.58	16.58	30.00	30.00
			5785	12.41	16.41	30.00	30.00
			5825	12.20	16.20	30.00	30.00

Test Plots:

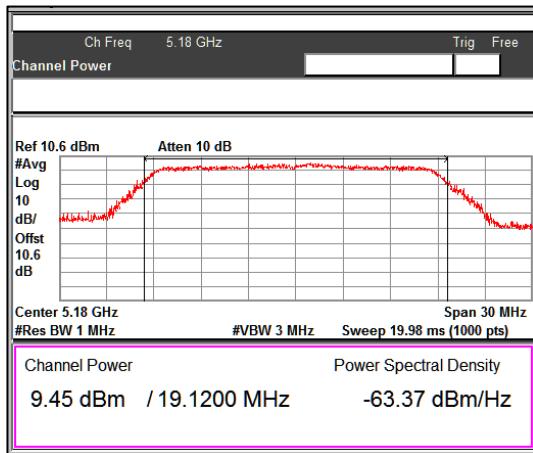

Channel frequency: 5180MHz

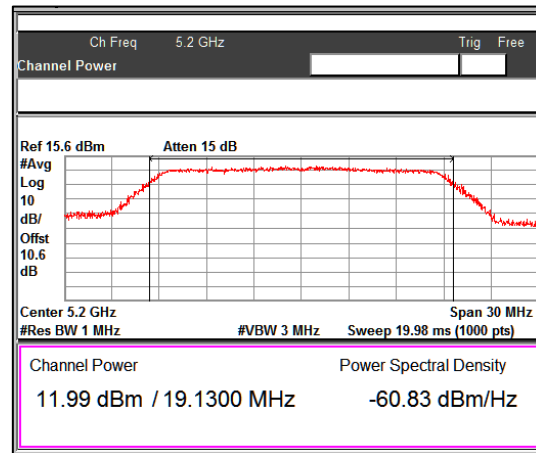

Channel frequency: 5200MHz

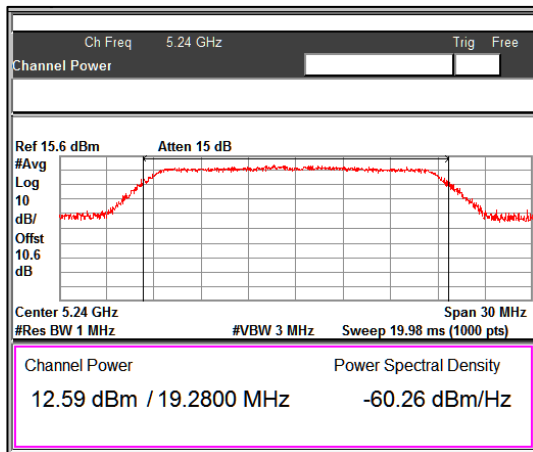

Channel frequency: 5240MHz

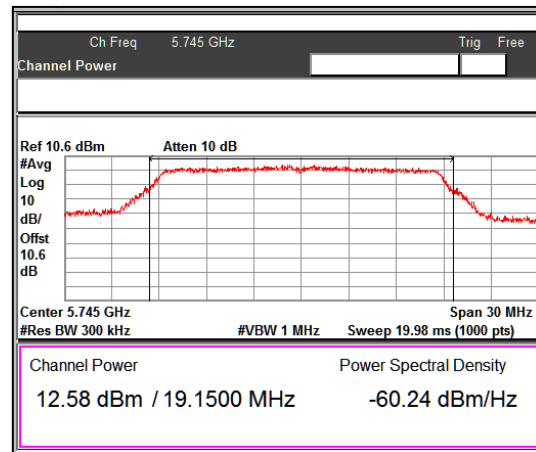

Channel frequency: 5745MHz

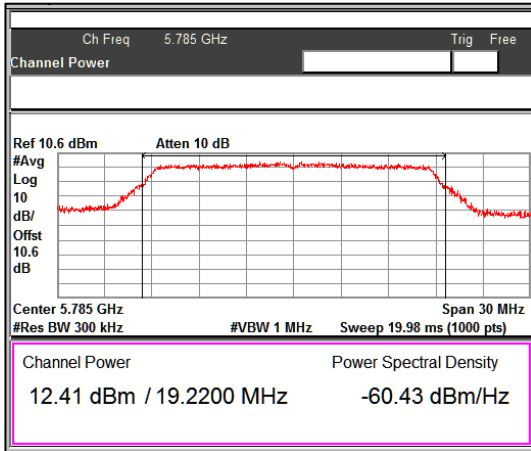

Channel frequency: 5785MHz

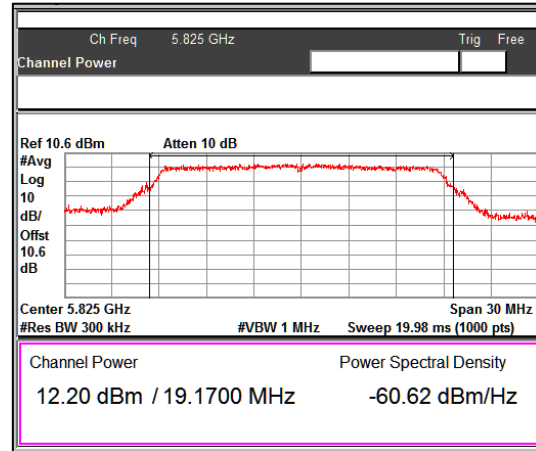

Channel frequency: 5825MHz

Modulation: 802.11ac VHT40

Mode	BW	Data rate	Channel frequency (MHz)	Measured Average Power	Measured e.i.r.p (dBm)	FCC Limit (dBm)	ISED Limit (dBm)
ac	40MHz	MCS0	5190	7.04	11.04	30.00	23.00
			5230	10.10	14.10	30.00	23.00
			5755	8.74	12.74	30.00	30.00
			5795	8.79	12.79	30.00	30.00

Test Plots:

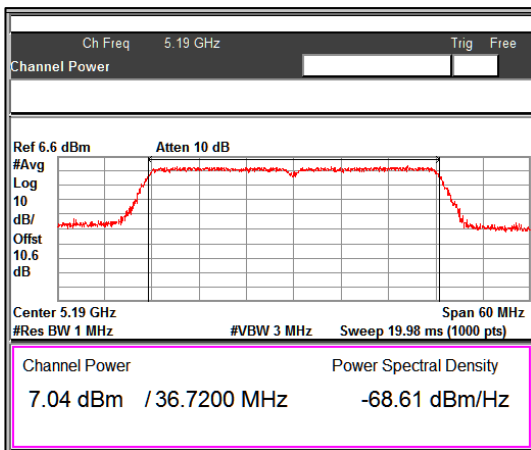

Channel frequency: 5190MHz

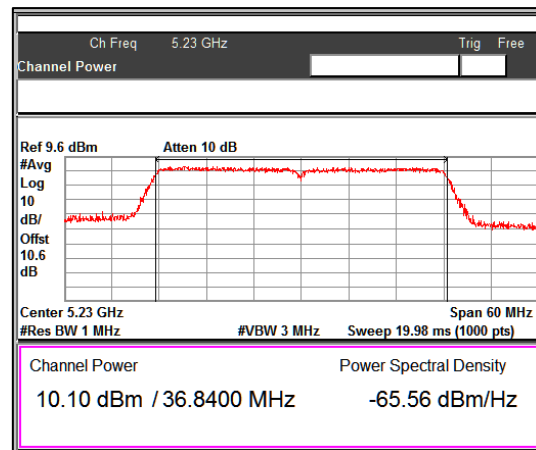

Channel frequency: 5230MHz

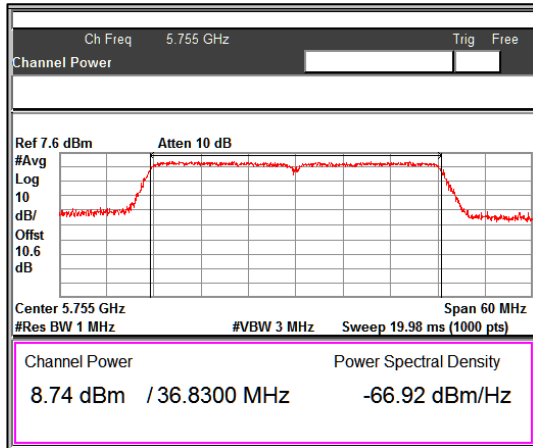

Channel frequency: 5755MHz

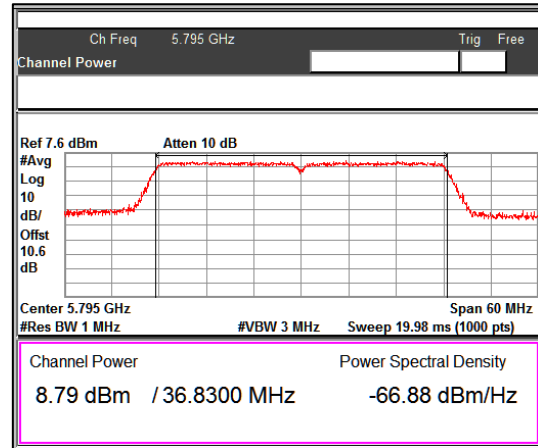

Channel frequency: 5795MHz

Modulation: 802.11ac VHT80

Mode	BW	Data rate	Channel frequency (MHz)	Measured Average Power	Measured e.i.r.p (dBm)	FCC Limit (dBm)	ISED Limit (dBm)
ac	80MHz	MCS0	5210	6.09	10.09	30.00	23.00
			5775	7.47	11.47	30.00	30.00

Test Plots:

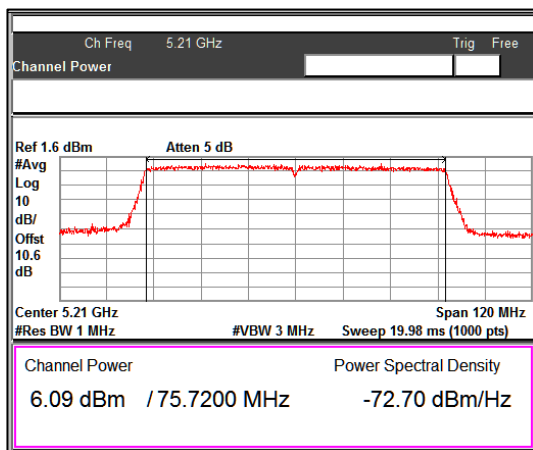

Channel frequency: 5210MHz

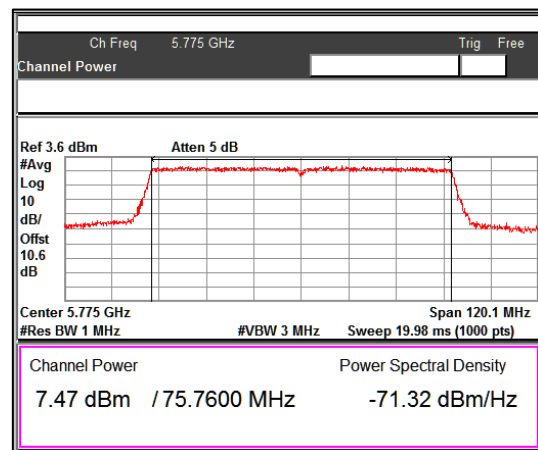

Channel frequency: 5775MHz

7.2 Spurious Radiated Emissions & Restricted Bands of Operation

Result

Pass

Test Specification	FCC part 15 Subpart C Section 15.407 (b) (15.205 & 15.209) / RSS 247 Issue 2 Section 6.2.1 & 6.2.4 / RSS Gen Issue 5 Section 8.9 & 8.10
Test Method	ANSI C 63.10 – 2013
Measurement Bandwidth	100kHz for below 1GHz 1MHz for above 1GHz
Measurement Location	Semi Anechoic Chamber 30MHz - 1 GHz Fully Anechoic Chamber 1 GHz - 40GHz
Measuring Distance	3 m
Detector	Refer Remark
Requirement	As per the limits mentioned in the below table
Test setup	Refer TEST METHODOLOGY

Limit:

Table 6: Undesirable emission limits

Frequency Band	Limit
UNII-1 (5.15-5.25 GHz)	e.i.r.p. -27dBm [68.2 dBuV/3m]
UNII-3(5.725-5.85 GHz)	5.715 GHz to 5.725 GHz - e.i.r.p. -17dBm [78.2 dBuV/3m] 5.85 GHz to 5.86 GHz - e.i.r.p. -17dBm [78.2 dBuV/3m] other frequency range - e.i.r.p. -27dBm [68.2 dBuV/3m]

Table 7: Transmitter limits for Radiated emission

Frequency (MHz)	Field strength (μV/m)	Field strength (dBμV/m)	Distance of Measurement (m)
0.009 – 0.490	2400/F(kHz)	48.50 – 13.80	300*
0.490 – 1.705	24000/F(kHz)	33.80 – 23.00	30*
1.705 -30	30	29.54	30*
30-88	100	40.0	3
88-216	150	43.5	3
216-960	200	46.0	3
Above 960	500	54.0	3

Remark: * The limit shows in the table above of frequency range 0.009 – 0.490, 0.490 – 1.705 MHz and 1.705-30MHz is at 300 meter, 30 meter and 30 meter range respectively, which corresponds to 128.51 – 93.80, 73.80 – 62.96 and 69.54 dBμV/m at 3m range by extrapolation calculation and the measurement of loop antenna.

The emission limits shown in the above table are based on measurements employing a CISPR quasi-peak detector except for the frequency bands 9–90 kHz, 110–490 kHz and above 1000 MHz Radiated emission limits in these three bands are based on measurements employing an average detector.

Test Condition:

Normal Test Condition:

Temperature (Norm) = + 22.5 °C Voltage = 110V, 60Hz AC & 3.7V of Li-Po Battery Relative humidity: 62 %

Test results:

Note: All the losses are included during measurement and final values are mentioned in the test report. Refer TEST METHODOLOGY for more details

Test results for Frequency range : 9kHz – 30MHz

No Emissions found in the frequency range 9kHz – 30MHz

Test results for frequency range 30MHz – 1GHz

Antenna Polarization	Measured Frequency (MHz)	Measured Emission (dBµV/m)	Limit (dBµV/m)	Margin (dB)
Vertical	47.994(Qp)	32.76	40.00	-7.24
	56.676(Qp)	27.75	40.00	-12.25
	58.152(Qp)	29.13	40.00	-10.87
	261.59(Pk)	33.60	46.00	-12.40
	332.78(Pk)	36.20	46.00	-9.80
	500.00(Pk)	35.80	46.00	-10.20
	599.99(Pk)	32.80	46.00	-13.20
Horizontal	47.97(Pk)	22.10	40.00	-17.90
	56.70(Pk)	28.30	40.00	-11.70
	66.87(Pk)	25.00	40.00	-15.00
	146.67(Pk)	31.40	43.50	-12.10
	344.42(Pk)	40.00	46.00	-6.00
	400.01(Pk)	37.30	46.00	-8.70
	500.00(Pk)	39.00	46.00	-7.00
	599.99(Pk)	33.90	46.00	-12.10
	800.00(Pk)	34.50	46.00	-11.50

Note: Testing performed both the modes with Charging mode & Battery for reporting mentioned only Charging mode condition

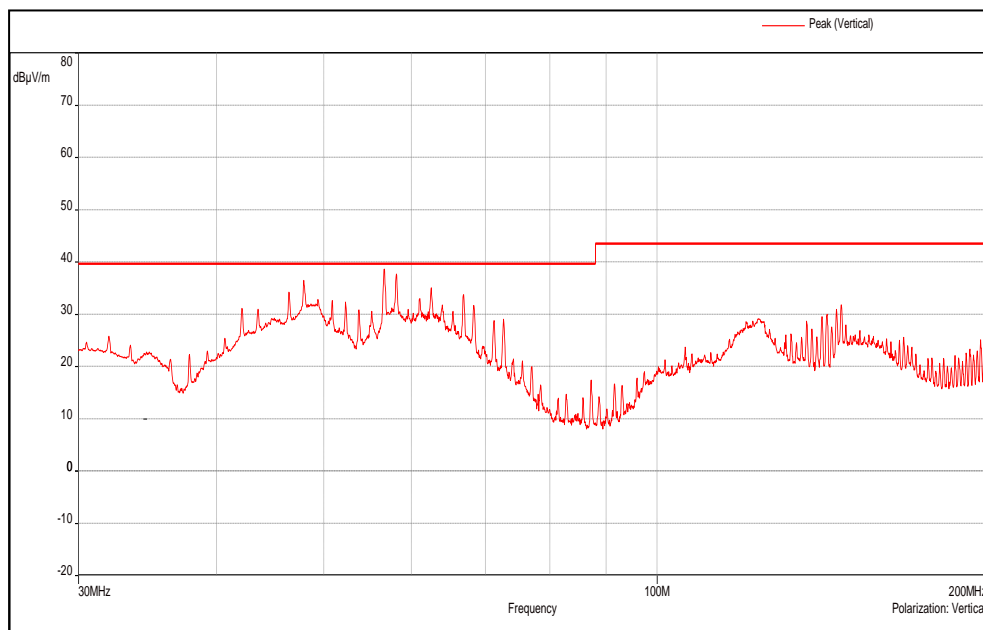

Channel Frequency 30MHz – 200MHz

Polarization Vertical

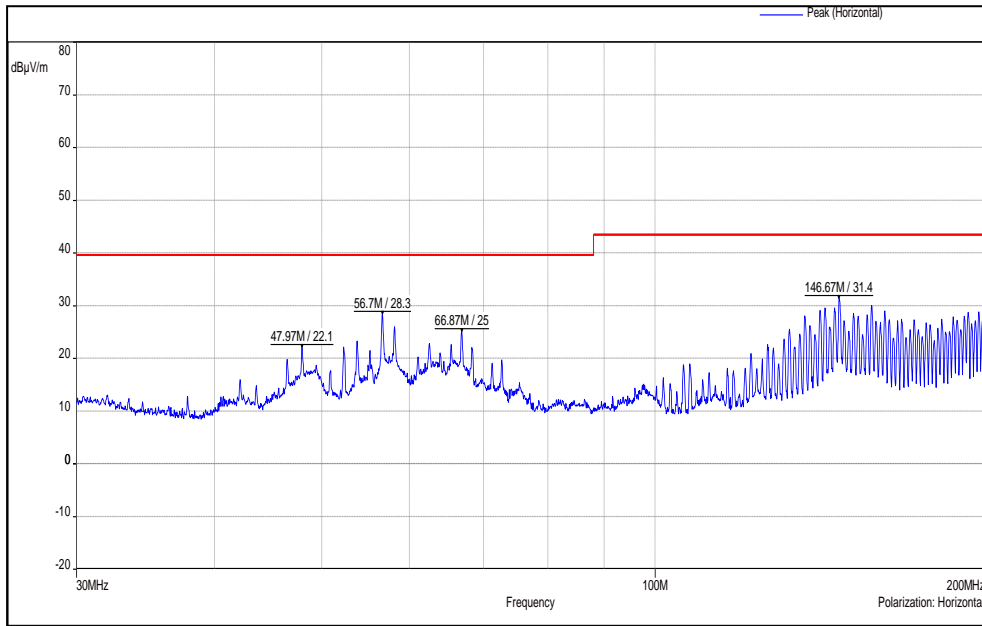

Channel Frequency 30MHz – 200MHz

Polarization Horizontal

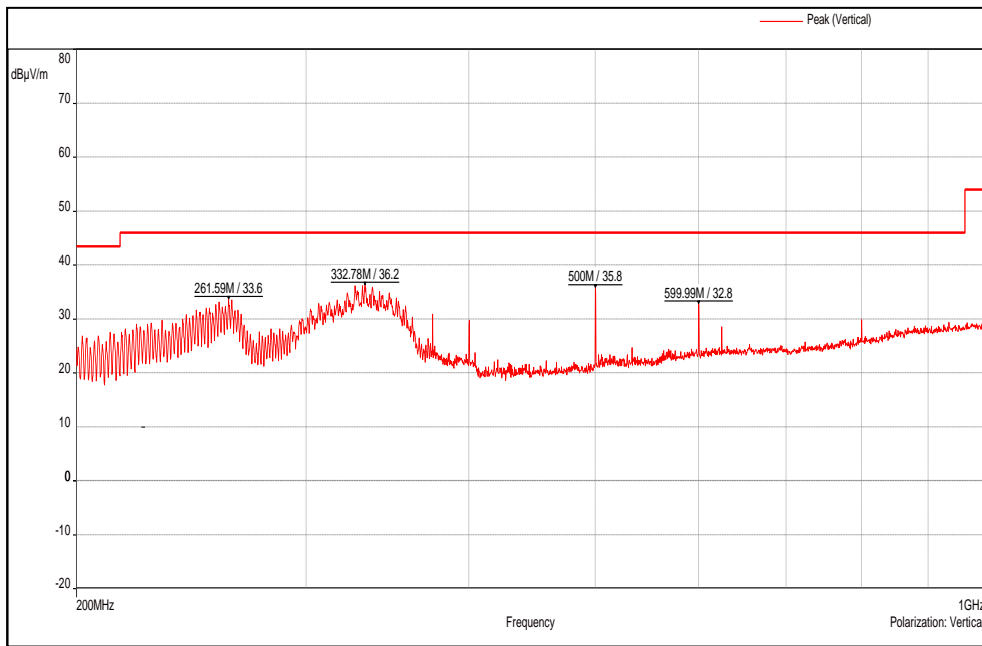

Channel Frequency 200MHz – 1GHz

Polarization Vertical

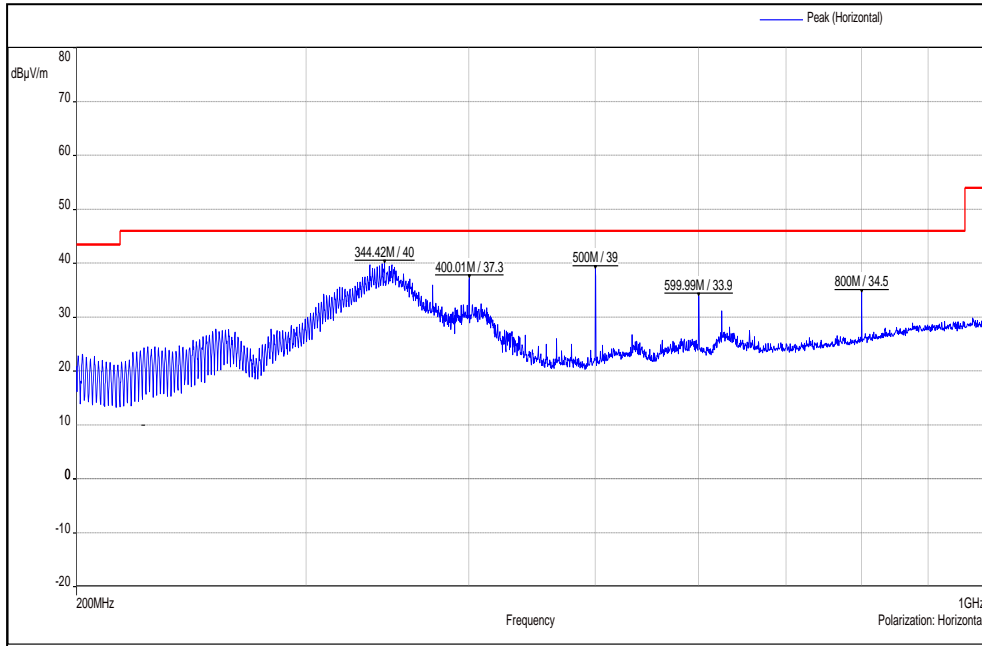

Channel Frequency 200MHz – 1GHz

Polarization Horizontal

Test results for frequency range – 1GHz to 40 GHz

Modulation: 802.11a
Data rate: 6Mbps

UNII Bands	Channel Frequency (MHz)	Frequency (MHz)	Polarization	Emission (dBµV/m)	Limit (dBµV/m)	Margin (dB)
UNII 1	5180	5180 (Pk)	Vertical	89.35	-	-
		5180 (Av)		80.11	-	-
		5150 (Pk)		44.06	74*	-29.94
		5150 (Av)		32.23	54*	-21.77
		10360 (Pk)		52.38	68.23	-15.85
		10360 (Av)		39.67	54	-14.33
		15540 (Pk)		53.76	68.23	-14.47
		15540 (Av)		41.60	54	-12.40
		5180 (Pk)	Horizontal	94.59	-	-
		5180 (Av)		85.29	-	-
		5150 (Pk)		48.18	74*	-25.82
		5150 (Av)		34.99	54*	-19.01
		10360 (Pk)		51.88	68.23	-16.35
		10360 (Av)		39.78	54	-14.22
		15540 (Pk)		53.76	68.23	-14.47
		15540 (Av)		41.62	54	-12.38
	5200	Vertical	5200 (Pk)	92.34	-	-
			5200 (Av)	82.84	-	-
			5350 (Pk)	42.09	74*	-31.91
			5350 (Av)	30.01	54*	-23.99
			10400 (Pk)	52.04	68.23	-16.19
			10400 (Av)	40.12	54	-13.88
			15600 (Pk)	54.07	68.23	-14.16
			15600 (Av)	41.29	54	-12.71
		Horizontal	5200 (Pk)	97.16	-	-
			5200 (Av)	87.66	-	-
			5350 (Pk)	46.64	74*	-27.36
			5350 (Av)	31.86	54*	-22.14
			10400 (Pk)	52.24	68.23	-15.99
			10400 (Av)	40.17	54	-13.83
			15600 (Pk)	53.22	68.23	-15.01
			15600 (Av)	41.29	54	-12.71
	5240	Vertical	5240 (Pk)	93.96	-	-
			5240 (Av)	84.59	-	-
			5350 (Pk)	42.11	74*	-31.89
			5350 (Av)	29.64	54*	-24.36
			10480 (Pk)	52.66	68.23	-15.57
			10480 (Av)	40.72	54	-13.28
			15720 (Pk)	54.69	68.23	-13.54
			15720 (Av)	41.52	54	-12.48
		Horizontal	5240 (Pk)	92.61	-	-
			5240 (Av)	83.45	-	-
			5350 (Pk)	43.03	74*	-30.97
			5350 (Av)	29.76	54*	-24.24
			10480 (Pk)	53.22	68.23	-15.01
			10480 (Av)	40.82	54	-13.18
			15720 (Pk)	53.25	68.23	-14.98
			15720 (Av)	41.40	54	-12.60

UNII-3	5745	5745 (Pk)	Vertical	97.85	-	-
		5745 (Av)		88.35	-	-
		5715(Pk)		60.62	78.2*	-17.58
		5725(Pk)		65.20	78.2*	-13.00
		11490 (Pk)		55.29	68.23	-12.94
		11490 (Av)		43.18	54	-10.82
		17235 (Pk)		57.11	68.23	-11.12
		17235 (Av)		44.79	54	-9.21
		5745 (Pk)	Horizontal	102.64	-	-
		5745 (Av)		93.43	-	-
		5715(Pk)		65.60	78.2*	-12.6
		5725(Pk)		70.50	78.2*	-7.7
		11490 (Pk)		57.49	68.23	-10.74
		11490 (Av)		44.01	54	-9.99
		17235 (Pk)		58.12	68.23	-10.11
		17235 (Av)		44.17	54	-9.83
	5785	Vertical	5785 (Pk)	98.29	-	-
			5785 (Av)	88.94	-	-
			5850 (Pk)	44.26	78.2*	-33.94
			5860 (Pk)	44.34	78.2*	-33.86
			11570 (Pk)	54.62	68.23	-13.61
			11570 (Av)	42.80	54	-11.20
			17355 (Pk)	57.52	68.23	-10.71
			17355 (Av)	45.58	54	-8.42
		5785 (Pk)	Horizontal	102.70	-	-
		5785 (Av)		93.50	-	-
		5850 (Pk)		46.96	78.2*	-31.24
		5860 (Pk)		48.29	78.2*	-29.91
		11570 (Pk)		56.68	68.23	-11.55
		11570 (Av)		44.38	54	-9.62
		17355 (Pk)		57.92	68.23	-10.31
		17355 (Av)		45.59	54	-8.41
	5825	Vertical	5825 (Pk)	99.68	-	-
			5825 (Av)	89.23	-	-
			5850 (Pk)	60.87	78.2*	-17.33
			5860 (Pk)	56.54	78.2*	-21.66
			11650 (Pk)	53.55	68.23	-14.68
			11650 (Av)	42.41	54	-11.59
			17475 (Pk)	58.50	68.23	-9.73
			17475 (Av)	46.94	54	-7.06
		5825 (Pk)	Horizontal	104.02	-	-
		5825 (Av)		94.17	-	-
		5850 (Pk)		67.87	78.2*	-10.33
		5860 (Pk)		62.90	78.2*	-15.30
		11650 (Pk)		54.34	68.23	-13.89
		11650 (Av)		42.75	54	-11.25
		17475 (Pk)		58.93	68.23	-9.30
		17475 (Pk)		46.94	54	-7.06

Note:

* : Indicate restricted band frequency in 15.205

Pk: Peak Detector; Av: Average Detector

Prüfbericht - Nr.:
Test Report No.:

ULR-TC568822300000061F

Seite 31 von 56
Page 31 of 56

Modulation: 802.11n HT20
Data rate: MCS0

UNII Bands	Channel Frequency (MHz)	Frequency (MHz)	Polarization	Emission (dBµV/m)	Limit (dBµV/m)	Margin (dB)	
UNII 1	5180	5180 (Pk)	Vertical	86.87	-	-	
		5180 (Av)		76.97	-	-	
		5150 (Pk)		43.55	74*	-30.45	
		5150 (Av)		30.91	54*	-23.09	
		10360 (Pk)		51.08	68.23	-17.15	
		10360 (Av)		39.77	54	-14.23	
		15540 (Pk)		53.32	68.23	-14.91	
		15540 (Av)		41.58	54	-12.42	
		5180 (Pk)		93.77	-	-	
		5180 (Av)	83.94	-	-		
		5150 (Pk)	49.26	74*	-24.74		
		5150 (Av)	33.46	54*	-20.54		
		10360 (Pk)	51.75	68.23	-16.48		
		10360 (Av)	39.73	54	-14.27		
		15540 (Pk)	54.15	68.23	-14.08		
		15540 (Av)	41.62	54	-12.38		
		5200	Vertical	5200 (Pk)	88.98	-	-
				5200 (Av)	78.92	-	-
	5350 (Pk)			42.22	74*	-31.78	
	5350 (Av)			29.48	54*	-24.52	
	10400 (Pk)			51.74	68.23	-16.49	
	10400 (Av)			40.10	54	-13.90	
	15600 (Pk)			53.13	68.23	-15.10	
	15600 (Av)			41.30	54	-12.70	
	Horizontal			5200 (Pk)	95.66	-	-
			5200 (Av)	86.43	-	-	
			5350 (Pk)	42.92	74*	-31.08	
			5350 (Av)	30.97	54*	-23.03	
			10400 (Pk)	52.68	68.23	-15.55	
			10400 (Av)	40.19	54	-13.81	
			15600 (Pk)	52.84	68.23	-15.39	
			15600 (Av)	41.33	54	-12.67	
			5240	Vertical	5240 (Pk)	92.03	-
	5240 (Av)				81.98	-	-
	5350 (Pk)	42.71			74*	-31.29	
	5350 (Av)	29.40			54*	-24.60	
	10480 (Pk)	51.91			68.23	-16.32	
	10480 (Av)	40.82			54	-13.18	
	15720 (Pk)	53.13			68.23	-15.10	
	15720 (Av)	41.60			54	-12.40	
	Horizontal	5240 (Pk)			97.83	-	-
		5240 (Av)		88.36	-	-	
		5350 (Pk)		42.30	74*	-31.70	
		5350 (Av)		30.49	54*	-23.51	
		10480 (Pk)		53.38	68.23	-14.85	
		10480 (Av)		40.97	54	-13.03	
		15720 (Pk)		54.14	68.23	-14.09	
		15720 (Av)		41.65	54	-12.35	

UNII-3	5745	5745 (Pk)	Vertical	98.17	-	-
		5745 (Av)		88.03	-	-
		5715(Pk)		63.21	78.2*	-14.99
		5725(Pk)		69.47	78.2*	-8.73
		11490 (Pk)		55.08	68.23	-13.15
		11490 (Av)		43.37	54	-10.63
		17235 (Pk)		56.78	68.23	-11.45
		17235 (Av)		44.98	54	-9.02
		5745 (Pk)	Horizontal	102.69	-	-
		5745 (Av)		92.45	-	-
		5715(Pk)		67.84	78.2*	-10.36
		5725(Pk)		73.47	78.2*	-4.73
		11490 (Pk)		55.97	68.23	-12.26
		11490 (Av)		43.39	54	-10.61
		17235 (Pk)		55.98	68.23	-12.25
		17235 (Av)		45.03	54	-8.97
	5785	Vertical	5785 (Pk)	98.91	-	-
			5785 (Av)	88.78	-	-
			5850 (Pk)	45.26	78.2*	-32.94
			5860 (Pk)	44.59	78.2*	-33.61
			11570 (Pk)	54.99	68.23	-13.24
			11570 (Av)	42.93	54	-11.07
			17355 (Pk)	57.58	68.23	-10.65
			17355 (Av)	45.73	54	-8.27
		5785 (Pk)	Horizontal	103.01	-	-
		5785 (Av)		93.22	-	-
		5850 (Pk)		47.97	78.2*	-30.23
		5860 (Pk)		47.60	78.2*	-30.60
		11570 (Pk)		54.50	68.23	-13.73
		11570 (Av)		42.98	54	-11.02
		17355 (Pk)		57.22	68.23	-11.01
		17355 (Av)		45.66	54	-8.34
	5825	Vertical	5825 (Pk)	99.68	-	-
			5825 (Av)	89.32	-	-
			5850 (Pk)	60.87	78.2*	-17.33
			5860 (Pk)	56.54	78.2*	-21.66
			11650 (Pk)	54.61	68.23	-13.62
			11650 (Av)	42.61	54	-11.39
			17475 (Pk)	59.40	68.23	-8.83
			17475 (Av)	46.98	54	-7.02
		5825 (Pk)	Horizontal	104.02	-	-
		5825 (Av)		94.17	-	-
		5850 (Pk)		67.87	78.2*	-10.33
		5860 (Pk)		62.90	78.2*	-15.30
		11650 (Pk)		55.46	68.23	-12.77
		11650 (Av)		42.57	54	-11.43
		17475 (Pk)		58.29	68.23	-9.94
		17475 (Pk)		46.99	54	-7.01

Note:

*: Indicate restricted band frequency in 15.205

Pk: Peak Detector; Av: Average Detector

Prüfbericht - Nr.:
Test Report No.:

ULR-TC568822300000061F

Seite 33 von 56
Page 33 of 56

Modulation: 802.11ac VHT20
Data rate: MCS0

UNII Bands	Channel Frequency (MHz)	Frequency (MHz)	Polarization	Emission (dBµV/m)	Limit (dBµV/m)	Margin (dB)	
UNII 1	5180	5180 (Pk)	Vertical	88.10	-	-	
		5180 (Av)		78.63	-	-	
		5150 (Pk)		46.08	74*	-27.92	
		5150 (Av)		31.91	54*	-22.09	
		10360 (Pk)		51.90	68.23	-16.33	
		10360 (Av)		39.70	54	-14.30	
		15540 (Pk)		53.68	68.23	-14.55	
		15540 (Av)		41.66	54	-12.34	
		5180 (Pk)		94.23	-	-	
		5180 (Av)	84.83	-	-		
		5150 (Pk)	50.06	74*	-23.94		
		5150 (Av)	34.51	54*	-19.49		
		10360 (Pk)	51.09	68.23	-17.14		
		10360 (Av)	39.70	54	-14.30		
		15540 (Pk)	53.92	68.23	-14.31		
		15540 (Av)	41.62	54	-12.38		
		5200	Vertical	5200 (Pk)	90.87	-	-
				5200 (Av)	81.54	-	-
	5350 (Pk)			41.80	74*	-32.20	
	5350 (Av)			29.97	54*	-24.03	
	10400 (Pk)			51.20	68.23	-17.03	
	10400 (Av)			40.08	54	-13.92	
	15600 (Pk)			53.34	68.23	-14.89	
	15600 (Av)			41.35	54	-12.65	
	Horizontal			5200 (Pk)	95.32	-	-
			5200 (Av)	86.57	-	-	
			5350 (Pk)	43.19	74*	-30.81	
			5350 (Av)	30.19	54*	-23.81	
			10400 (Pk)	51.49	68.23	-16.74	
			10400 (Av)	40.19	54	-13.81	
			15600 (Pk)	52.63	68.23	-15.60	
			15600 (Av)	41.03	54	-12.97	
			5240	Vertical	5240 (Pk)	91.64	-
	5240 (Av)				81.24	-	-
	5350 (Pk)	41.58			74*	-32.42	
	5350 (Av)	29.33			54*	-24.67	
	10480 (Pk)	53.07			68.23	-15.16	
	10480 (Av)	40.71			54	-13.29	
	15720 (Pk)	52.96			68.23	-15.27	
	15720 (Av)	41.45			54	-12.55	
	Horizontal	5240 (Pk)			97.88	-	-
		5240 (Av)		88.62	-	-	
		5350 (Pk)		43.02	74*	-30.98	
		5350 (Av)		30.20	54*	-23.80	
		10480 (Pk)		52.81	68.23	-15.42	
		10480 (Av)		40.88	54	-13.12	
		15720 (Pk)		53.94	68.23	-14.29	
		15720 (Av)		41.50	54	-12.50	

UNII-3	5745	5745 (Pk)	Vertical	93.45	-	-
		5745 (Av)		82.88	-	-
		5715(Pk)		63.73	78.2*	-14.47
		5725(Pk)		59.63	78.2*	-18.57
		11490 (Pk)		55.36	68.23	-12.87
		11490 (Av)		43.32	54	-10.68
		17235 (Pk)		56.60	68.23	-11.63
		17235 (Av)		44.91	54	-9.09
		5745 (Pk)	Horizontal	102.37	-	-
		5745 (Av)		92.61	-	-
		5715(Pk)		73.07	78.2*	-5.13
		5725(Pk)		67.98	78.2*	-10.22
		11490 (Pk)		56.13	68.23	-12.10
		11490 (Av)		43.32	54	-10.68
		17235 (Pk)		56.23	68.23	-12.00
		17235 (Av)		44.97	54	-9.03
	5785	Vertical	5785 (Pk)	98.20	-	-
			5785 (Av)	88.14	-	-
			5850 (Pk)	45.48	78.2*	-32.72
			5860 (Pk)	44.16	78.2*	-34.04
			11570 (Pk)	54.39	68.23	-13.84
			11570 (Av)	42.87	54	-11.13
			17355 (Pk)	56.82	68.23	-11.41
			17355 (Av)	45.63	54	-8.37
		Horizontal	5785 (Pk)	102.80	-	-
			5785 (Av)	92.27	-	-
			5850 (Pk)	46.60	78.2*	-31.60
			5860 (Pk)	45.64	78.2*	-32.56
			11570 (Pk)	53.75	68.23	-14.48
			11570 (Av)	42.87	54	-11.13
			17355 (Pk)	58.14	68.23	-10.09
			17355 (Av)	45.58	54	-8.42
	5825	Vertical	5825 (Pk)	97.56	-	-
			5825 (Av)	87.55	-	-
			5850 (Pk)	61.49	78.2*	-16.71
			5860 (Pk)	54.99	78.2*	-23.21
			11650 (Pk)	54.61	68.23	-13.62
			11650 (Av)	42.58	54	-11.42
			17475 (Pk)	59.04	68.23	-9.19
			17475 (Av)	46.94	54	-7.06
		Horizontal	5825 (Pk)	104.07	-	-
			5825 (Av)	93.54	-	-
			5850 (Pk)	67.54	78.2*	-10.66
			5860 (Pk)	61.88	78.2*	-16.32
			11650 (Pk)	53.98	68.23	-14.25
			11650 (Av)	42.55	54	-11.45
			17475 (Pk)	58.44	68.23	-9.79
			17475 (Pk)	46.89	54	-7.11

Note:

* : Indicate restricted band frequency in 15.205

Pk: Peak Detector; Av: Average Detector

Prüfbericht - Nr.:
Test Report No.:

ULR-TC568822300000061F

Seite 35 von 56
Page 35 of 56

Modulation: 802.11n HT40
Data rate: MCS0

UNII Bands	Channel Frequency (MHz)	Frequency (MHz)	Polarization	Emission (dBµV/m)	Limit (dBµV/m)	Margin (dB)	
UNII 1	5190	5190 (Pk)	Vertical	84.18	-	-	
		5190 (Av)		73.74	-	-	
		5150 (Pk)		48.19	74*	-25.81	
		5150 (Av)		31.84	54*	-22.16	
		10380 (Pk)		51.92	68.23	-16.31	
		10380 (Av)		39.90	54	-14.10	
		15570 (Pk)		52.70	68.23	-15.53	
		15570 (Av)		40.79	54	-13.21	
		5190 (Pk)		Horizontal	87.71	-	-
		5190 (Av)			77.74	-	-
		5150 (Pk)			54.53	74*	-19.47
		5150 (Av)			34.31	54*	-19.69
		10380 (Pk)			51.39	68.23	-16.84
		10380 (Av)			39.91	54	-14.09
	15570 (Pk)	52.83	68.23		-15.40		
	15570 (Av)	40.74	54		-13.26		
	5230	Vertical	5230 (Pk)	84.84	-	-	
			5230 (Av)	74.60	-	-	
			5150 (Pk)	44.04	74*	-29.96	
			5150 (Av)	30.59	54*	-23.41	
			10460 (Pk)	53.05	68.23	-15.18	
			10460 (Av)	40.43	54	-13.57	
			15690 (Pk)	53.30	68.23	-14.93	
			15690 (Av)	41.03	54	-12.97	
		Horizontal	5230 (Pk)	91.52	-	-	
			5230 (Av)	81.94	-	-	
			5150 (Pk)	44.32	74*	-29.68	
			5150 (Av)	32.02	54*	-21.98	
10460 (Pk)			52.54	68.23	-15.69		
10460 (Av)			40.52	54	-13.48		
15690 (Pk)	52.52	68.23	-15.71				
	15690 (Av)	41.05	54	-12.95			

UNII 3	5755	5755 (Pk)	Vertical	90.29	-	-
		5755 (Av)		79.45	-	-
		5715(Pk)		57.41	78.2*	-20.79
		5725(Pk)		56.15	78.2*	-22.05
		11510 (Pk)		54.60	68.23	-13.63
		11510 (Av)		43.35	54	-10.65
		17265 (Pk)		56.20	68.23	-12.03
		17265 (Av)		44.13	54	-9.87
		5755 (Pk)		98.14	-	-
		5755 (Av)		87.50	-	-
		5715(Pk)		66.76	78.2*	-11.44
		5725(Pk)		64.20	78.2*	-14.00
		11510 (Pk)		55.16	68.23	-13.07
		11510 (Av)		43.35	54	-10.65
	17265 (Pk)	54.98	68.23	-13.25		
	17265 (Av)	44.11	54	-9.89		
	5795	5795 (Pk)	Vertical	92.80	-	-
		5795 (Av)		83.01	-	-
		5850 (Pk)		50.71	78.2*	-27.49
		5860 (Pk)		32.16	78.2*	-46.04
		11590 (Pk)		54.42	68.23	-13.81
		11590 (Av)		42.83	54	-11.17
		17385 (Pk)		56.94	68.23	-11.29
		17385 (Av)		45.51	54	-8.49
		5795 (Pk)		98.03	-	-
		5795 (Av)		87.96	-	-
		5850 (Pk)		57.69	78.2*	-20.51
		5860 (Pk)		56.41	78.2*	-21.79
11590 (Pk)		55.13		68.23	-13.10	
11590 (Av)		42.80		54	-11.20	
17385 (Pk)	57.16	68.23	-11.07			
17385 (Av)	45.49	54	-8.51			

Note:

* : Indicate restricted band frequency in 15.205

Pk: Peak Detector; Av: Average Detector

Prüfbericht - Nr.:
Test Report No.:

ULR-TC568822300000061F

Seite 37 von 56
Page 37 of 56

Modulation: 802.11ac VHT40
Data rate: MCS0

UNII Bands	Channel Frequency (MHz)	Frequency (MHz)	Polarization	Emission (dBµV/m)	Limit (dBµV/m)	Margin (dB)	
UNII 1	5190	5190 (Pk)	Vertical	83.01	-	-	
		5190 (Av)		72.76	-	-	
		5150 (Pk)		48.65	74*	-25.35	
		5150 (Av)		32.10	54*	-21.90	
		10380 (Pk)		51.90	68.23	-16.33	
		10380 (Av)		39.90	54	-14.10	
		15570 (Pk)		52.05	68.23	-16.18	
		15570 (Av)		40.84	54	-13.16	
		5190 (Pk)		Horizontal	87.75	-	-
		5190 (Av)			76.96	-	-
		5150 (Pk)			51.90	74*	-22.10
		5150 (Av)			33.57	54*	-20.43
		10380 (Pk)			51.66	68.23	-16.57
		10380 (Av)			39.42	54	-14.58
	15570 (Pk)	52.61	68.23		-15.62		
	15570 (Av)	40.89	54		-13.11		
	5230	Vertical	5230 (Pk)	85.34	-	-	
			5230 (Av)	75.10	-	-	
			5150 (Pk)	42.76	74*	-31.24	
			5150 (Av)	30.66	54*	-23.34	
			10460 (Pk)	51.75	68.23	-16.48	
			10460 (Av)	40.46	54	-13.54	
			15690 (Pk)	52.50	68.23	-15.73	
			15690 (Av)	41.07	54	-12.93	
		Horizontal	5230 (Pk)	89.50	-	-	
			5230 (Av)	79.40	-	-	
			5150 (Pk)	45.78	74*	-28.22	
			5150 (Av)	31.24	54*	-22.76	
10460 (Pk)			51.83	68.23	-16.40		
10460 (Av)			40.48	54	-13.52		
15690 (Pk)	52.83	68.23	-15.40				
15690 (Av)	41.05	54	-12.95				

UNII 3	5755	5755 (Pk)	Vertical	89.55	-	-	
		5755 (Av)		78.94	-	-	
		5715(Pk)		59.65	78.2*	-18.55	
		5725(Pk)		56.84	78.2*	-21.36	
		11510 (Pk)		55.37	68.23	-12.86	
		11510 (Av)		43.38	54	-10.62	
		17265 (Pk)		55.70	68.23	-12.53	
		17265 (Av)		44.17	54	-9.83	
		5755 (Pk)		Horizontal	97.21	-	-
		5755 (Av)			86.38	-	-
		5715(Pk)			64.02	78.2*	-14.18
		5725(Pk)			66.14	78.2*	-12.06
		11510 (Pk)			55.47	68.23	-12.76
		11510 (Av)			43.35	54	-10.65
		17265 (Pk)			56.41	68.23	-11.82
		17265 (Av)			44.09	54	-9.91
	5795	Vertical	5795 (Pk)	92.56	-	-	
			5795 (Av)	82.10	-	-	
			5850 (Pk)	53.10	78.2*	-25.10	
			5860 (Pk)	52.45	78.2*	-25.75	
			11590 (Pk)	54.41	68.23	-13.82	
			11590 (Av)	42.74	54	-11.26	
			17385 (Pk)	56.56	68.23	-11.67	
			17385 (Av)	45.43	54	-8.57	
		Horizontal	5795 (Pk)	98.94	-	-	
			5795 (Av)	88.01	-	-	
			5850 (Pk)	57.18	78.2*	-21.02	
			5860 (Pk)	58.69	78.2*	-19.51	
			11590 (Pk)	54.04	68.23	-14.19	
			11590 (Av)	42.78	54	-11.22	
			17385 (Pk)	57.11	68.23	-11.12	
			17385 (Av)	45.47	54	-8.53	

Note:

* : Indicate restricted band frequency in 15.205

Pk: Peak Detector; Av: Average Detector

Prüfbericht - Nr.:
Test Report No.:

ULR-TC568822300000061F

Seite 39 von 56
Page 39 of 56

Modulation: 802.11ac VHT80
Data rate: MCS0

UNII Bands	Channel Frequency (MHz)	Frequency (MHz)	Polarization	Emission (dBµV/m)	Limit (dBµV/m)	Margin (dB)
UNII 1	5210	5210 (Pk)	Vertical	76.81	-	-
		5210 (Av)		66.52	-	-
		5150 (Pk)		42.46	74*	-31.54
		5150 (Av)		30.44	54*	-23.56
		10420 (Pk)		52.06	68.23	-16.17
		10420 (Av)		40.16	54	-13.84
		15630 (Pk)		53.42	68.23	-14.81
		15630 (Av)		40.90	54	-13.10
		5210 (Pk)	Horizontal	83.50	-	-
		5210 (Av)		72.91	-	-
		5150 (Pk)		43.76	74*	-30.24
		5150 (Av)		31.54	54*	-22.46
		10420 (Pk)		52.06	68.23	-16.17
		10420 (Av)		40.17	54	-13.83
		15630 (Pk)		52.88	68.23	-15.35
		15630 (Av)		40.86	54	-13.14
UNII 3	5775	5775 (Pk)	Vertical	87.43	-	-
		5775 (Pk)		76.12	-	-
		11550 (Pk)		54.68	68.23	-13.55
		11550 (Pk)		42.92	54	-11.08
		17325 (Pk)		56.85	68.23	-11.38
		17325 (Av)		44.90	54	-9.10
		5775 (Pk)	Horizontal	93.59	-	-
		5775 (Pk)		83.05	-	-
		11550 (Pk)		54.53	68.23	-13.70
		11550 (Pk)		42.97	54	-11.03
		17325 (Pk)		56.34	68.23	-11.89
		17325 (Av)		44.88	54	-9.12

Test Plots:

Modulation : 802.11a
Data rate : 6Mbps

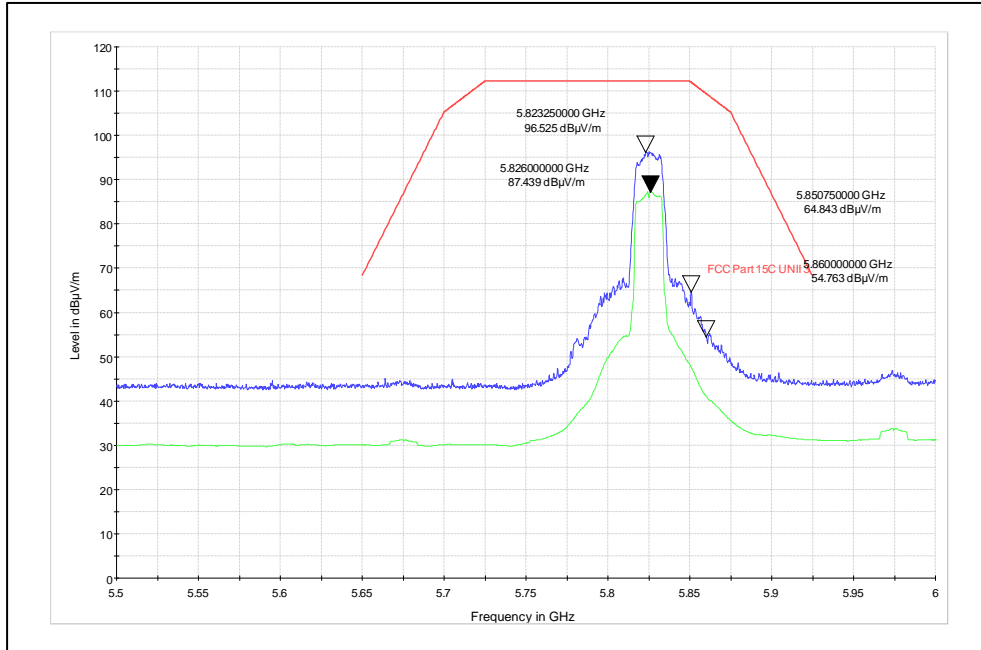

Channel frequency: 5825MHz

Polarization: Vertical

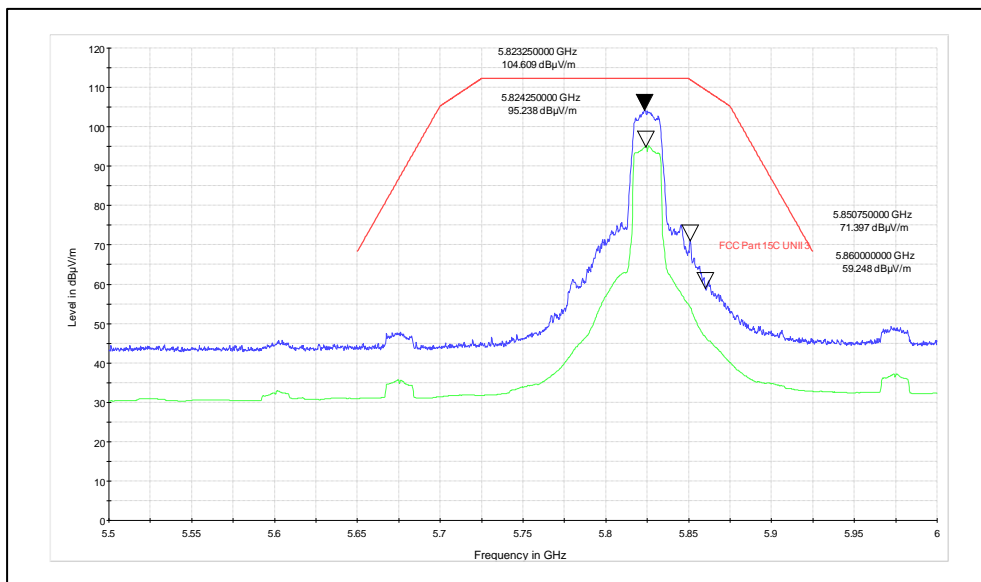

Channel frequency: 5825MHz

Polarization: Horizontal

Channel Frequency: 5825MHz

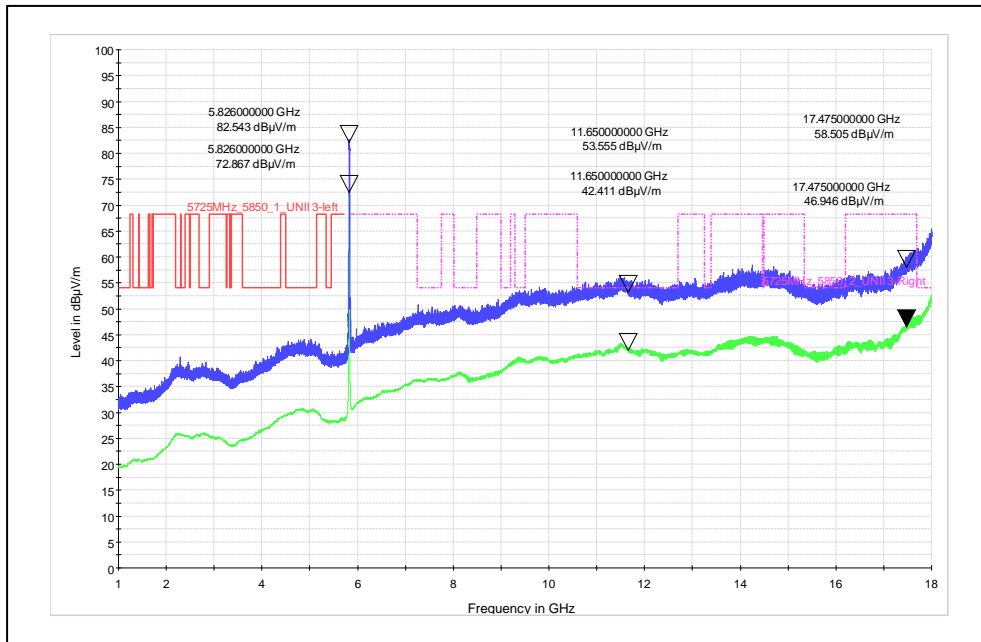

Frequency range: 1GHz-18GHz

Polarization: Vertical

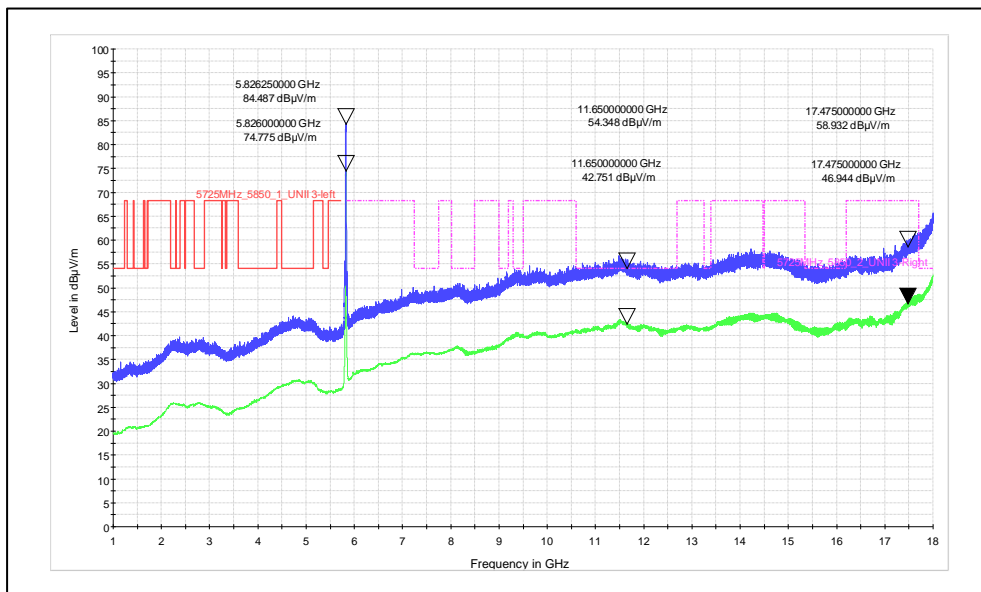

Frequency range: 1GHz-18GHz

Polarization: Horizontal

Modulation : 802.11n HT20
Data rate : MCS0

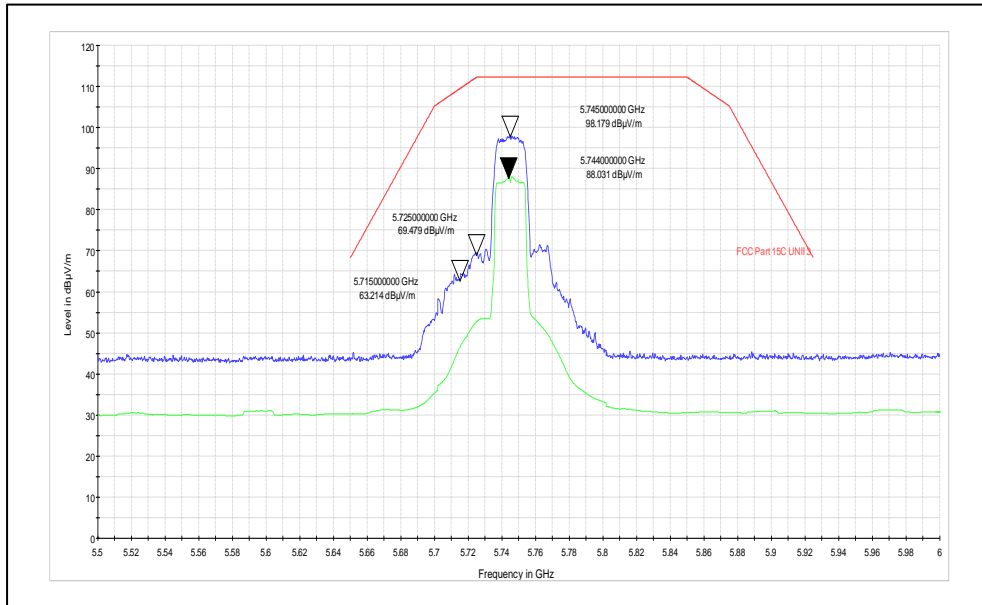

Channel frequency: 5745MHz

Polarization: Vertical

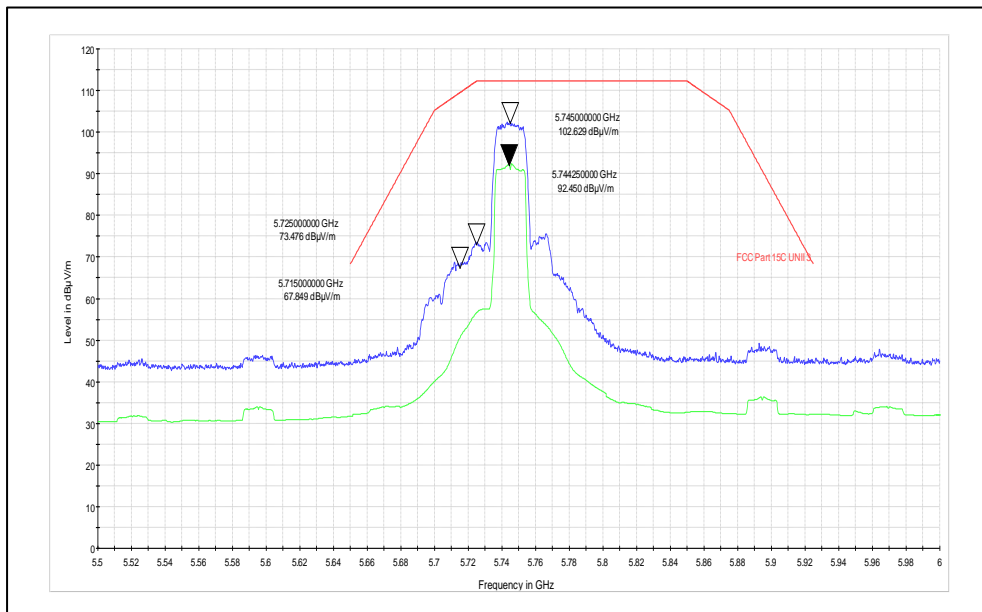

Channel frequency: 5745MHz

Polarization: Horizontal

Channel Frequency: 5745MHz

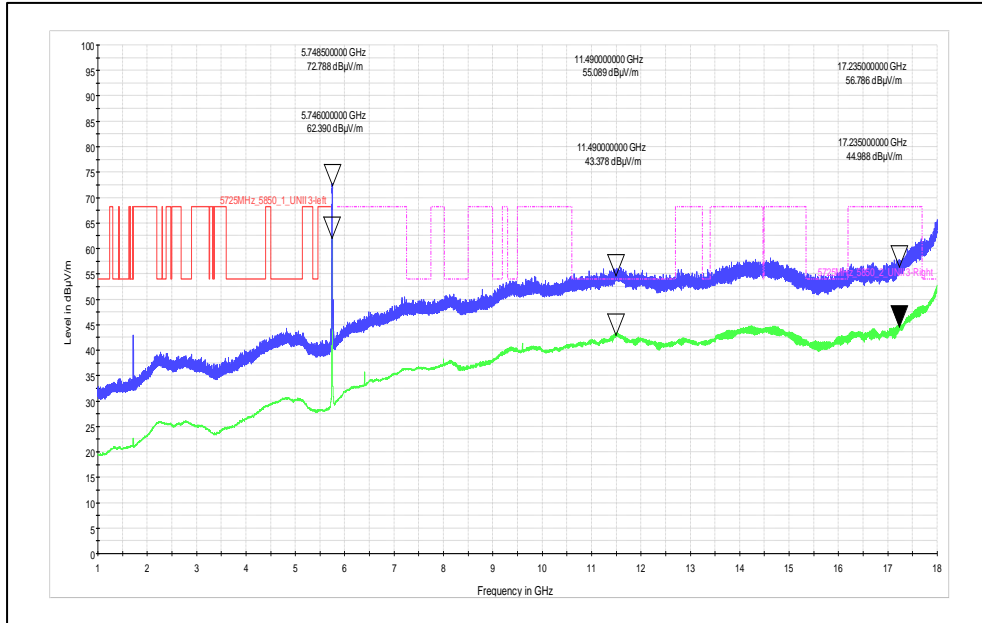

Frequency range: 1GHz-18GHz

Polarization: Vertical

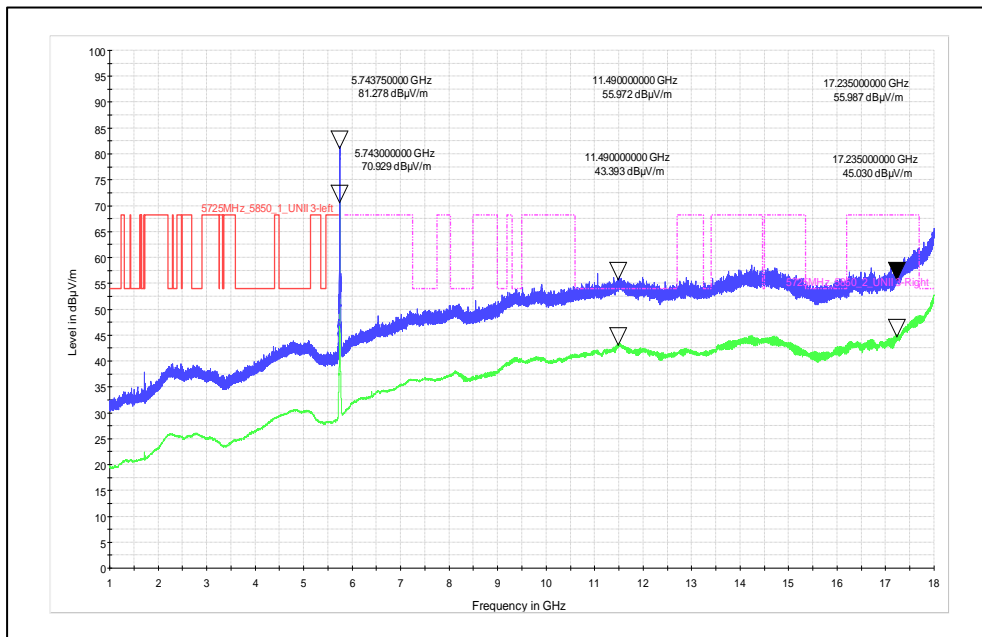

Frequency range: 1GHz-18GHz

Polarization: Horizontal

Modulation : 802.11ac VHT20
Data rate : MCS0

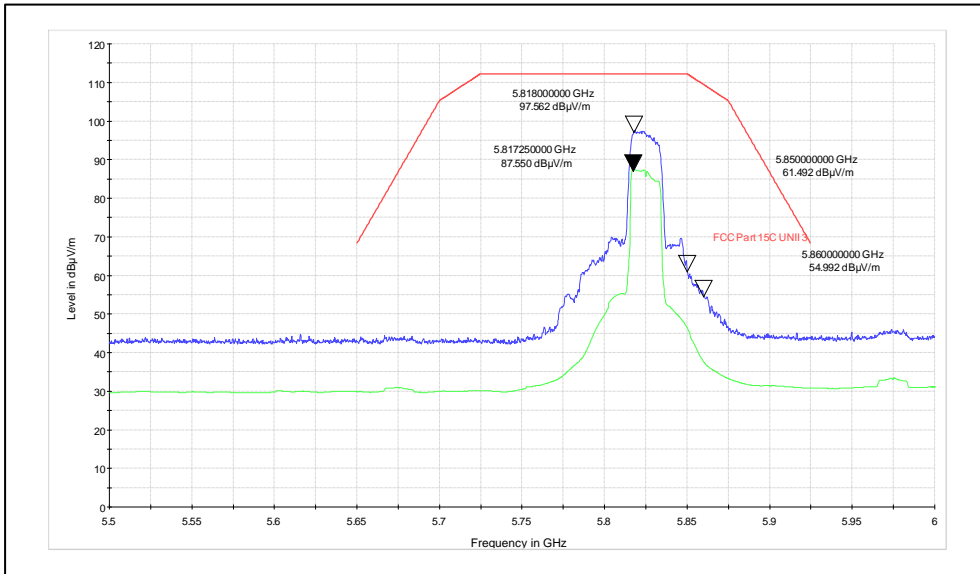

Channel frequency: 5825MHz

Polarization: Vertical

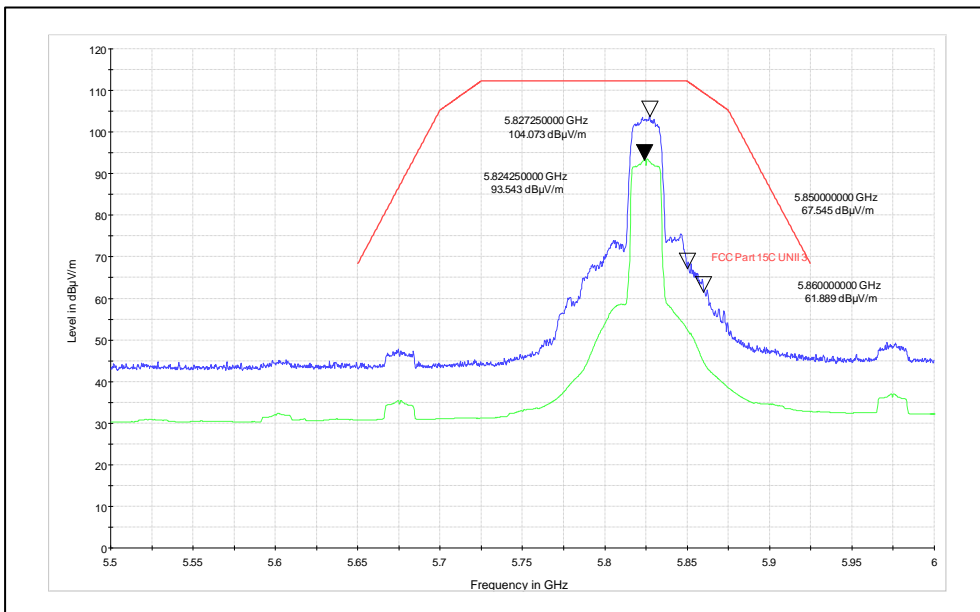

Channel frequency: 5825MHz

Polarization: Horizontal

Channel Frequency: 5825MHz

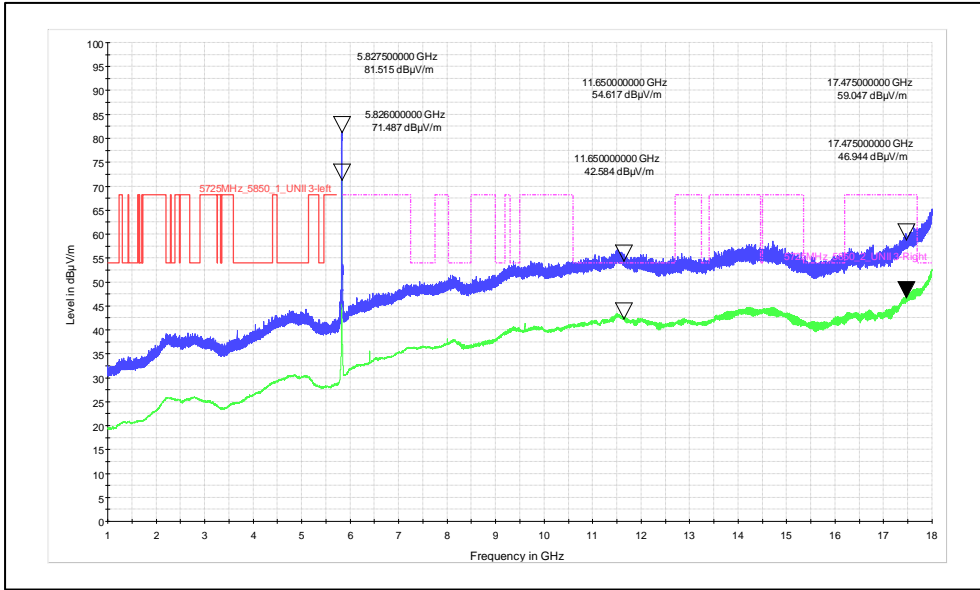

Frequency range: 1GHz-18GHz

Polarization: Vertical

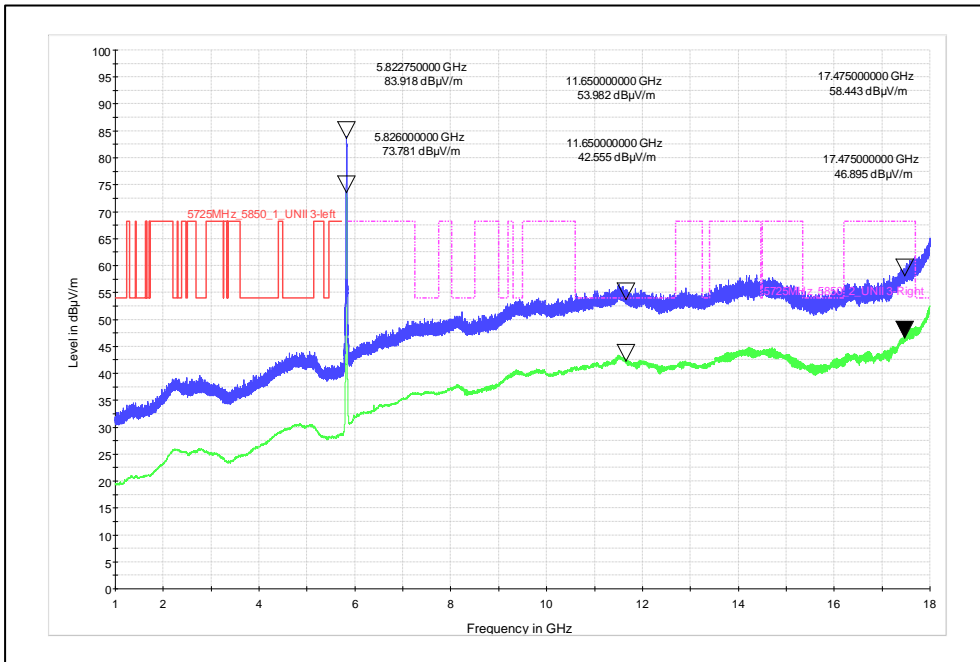

Frequency range: 1GHz-18GHz

Polarization: Horizontal

Modulation : 802.11n HT40
Data rate : MCS0

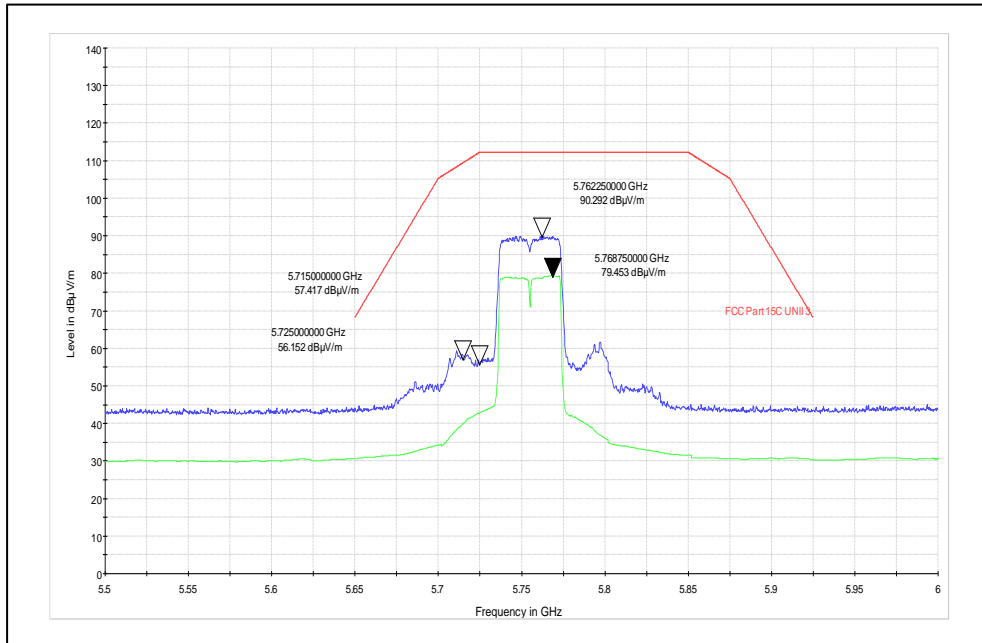

Channel frequency: 5755MHz

Polarization: Vertical

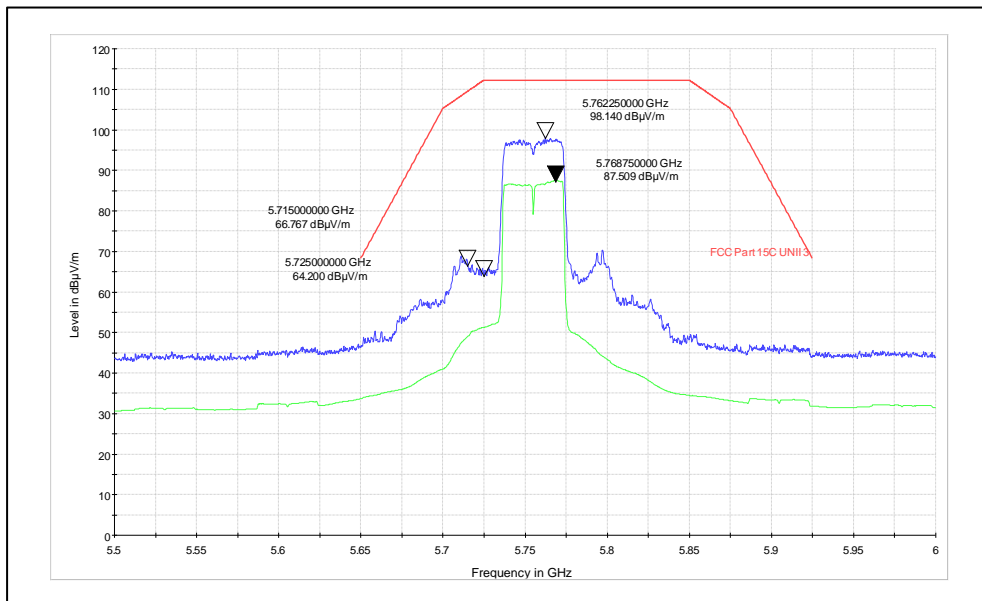

Channel frequency: 5755MHz

Polarization: Horizontal

Channel Frequency: 5755MHz

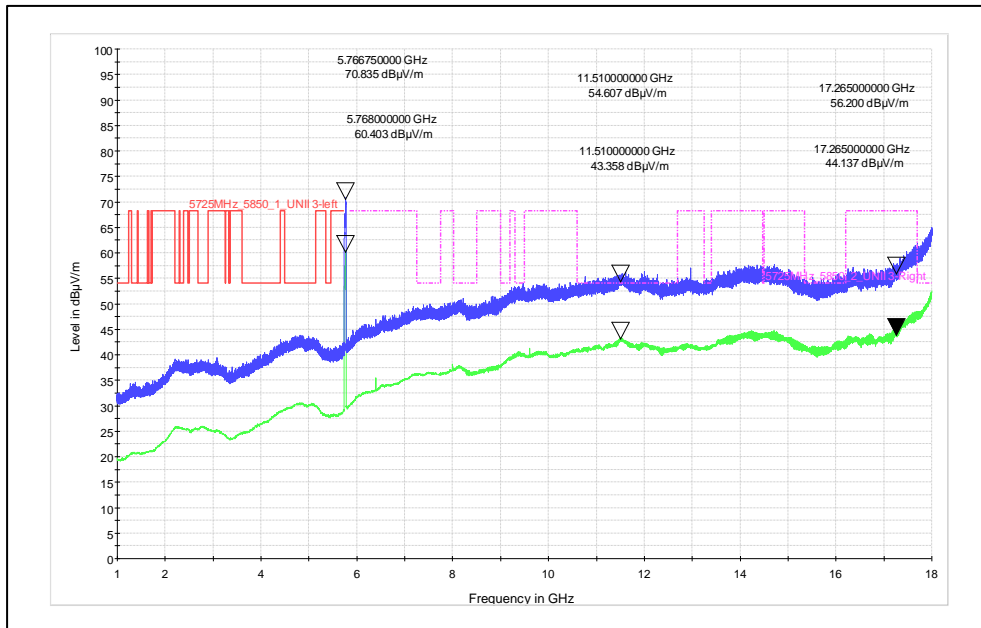

Frequency range: 1GHz-18GHz

Polarization: Vertical

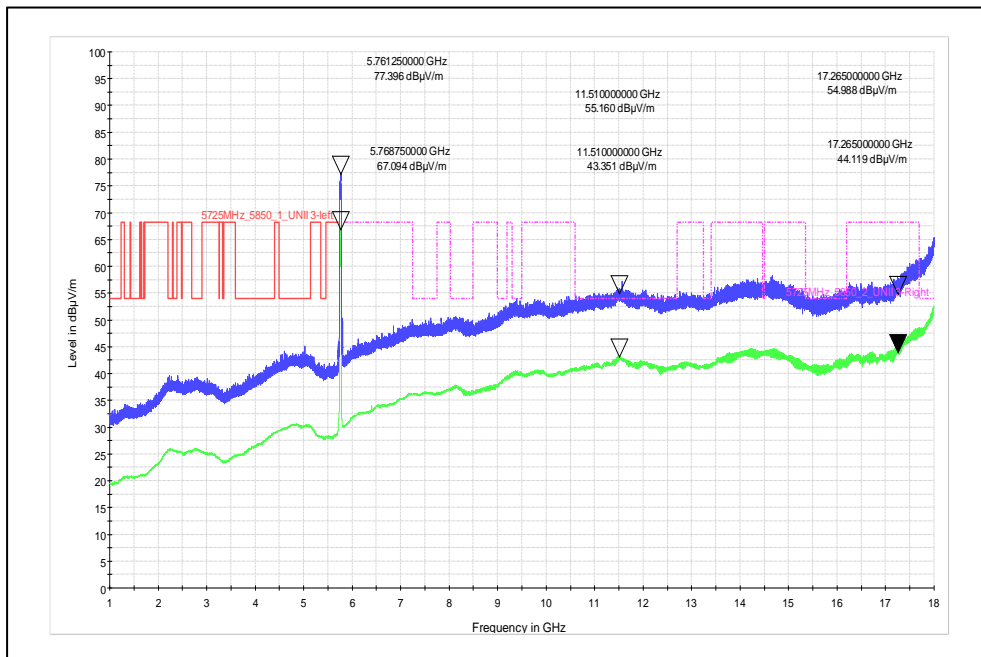

Frequency range: 1GHz-18GHz

Polarization: Horizontal

Modulation : 802.11ac VHT40
Data rate : MCS0

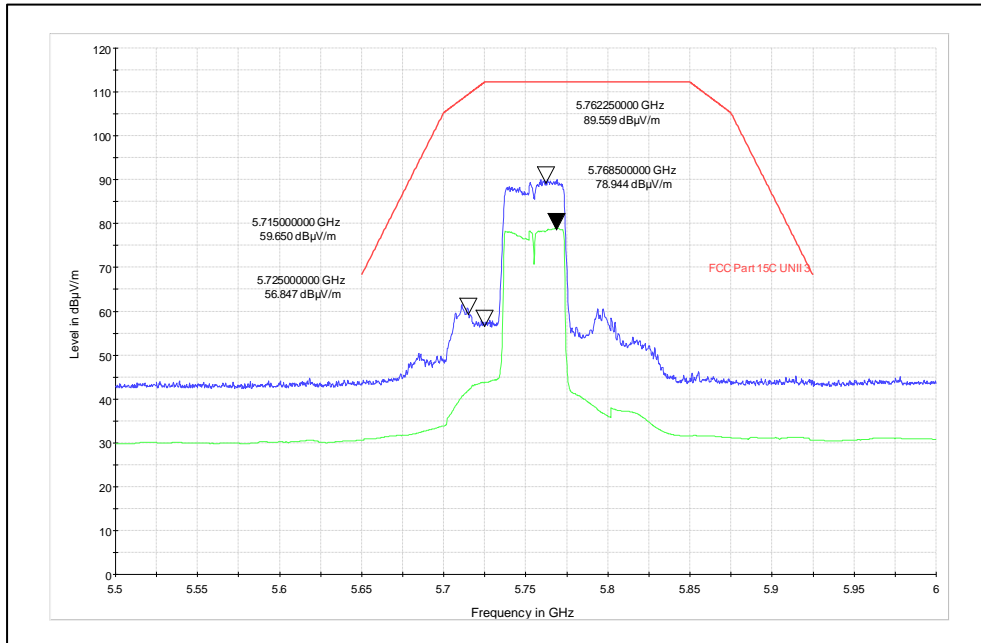

Channel frequency: 5755MHz

Polarization: Vertical

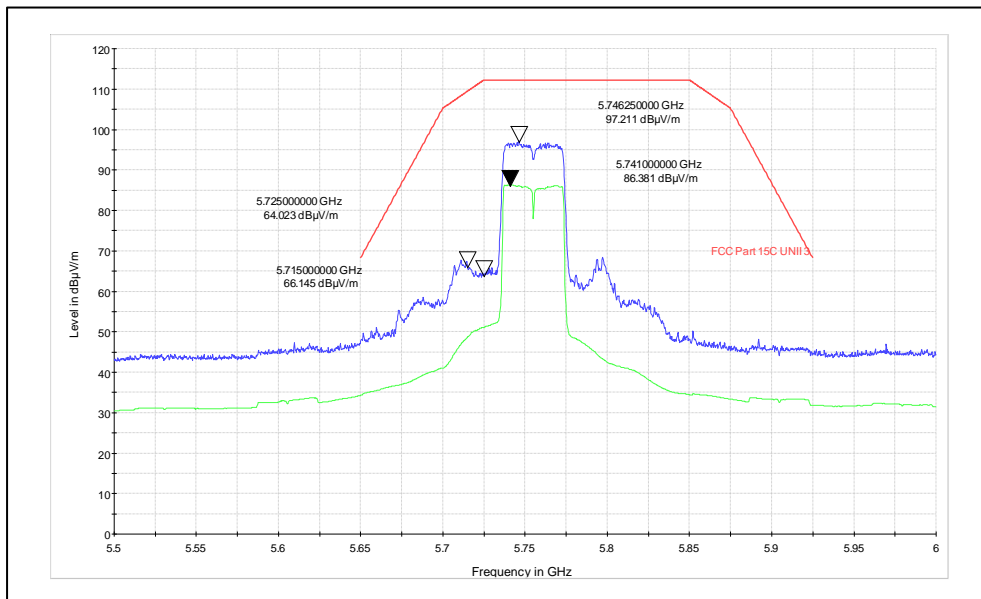

Channel frequency: 5755MHz

Polarization: Horizontal

Channel Frequency: 5755MHz

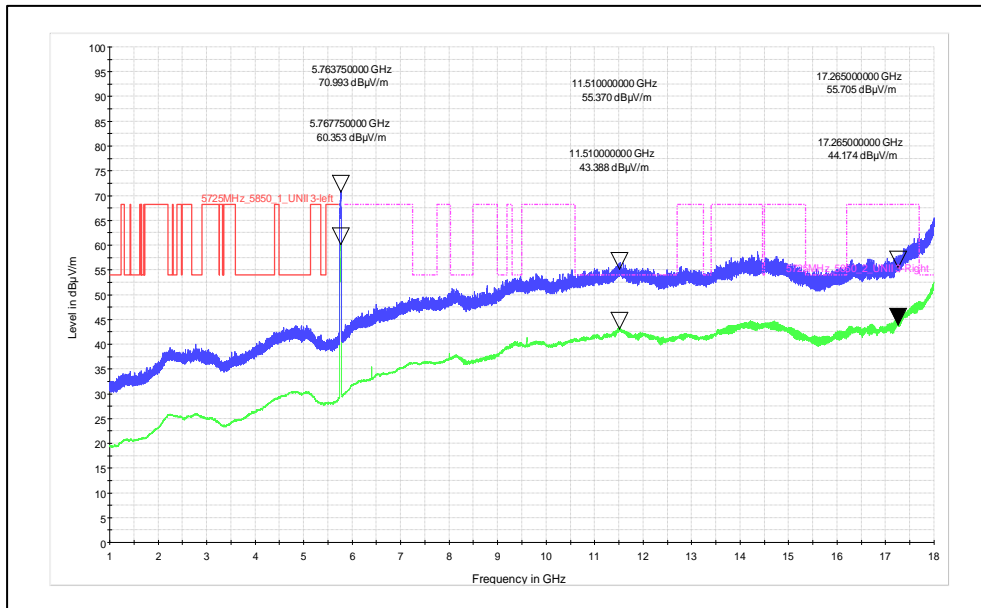

Frequency range: 1GHz-18GHz

Polarization: Vertical

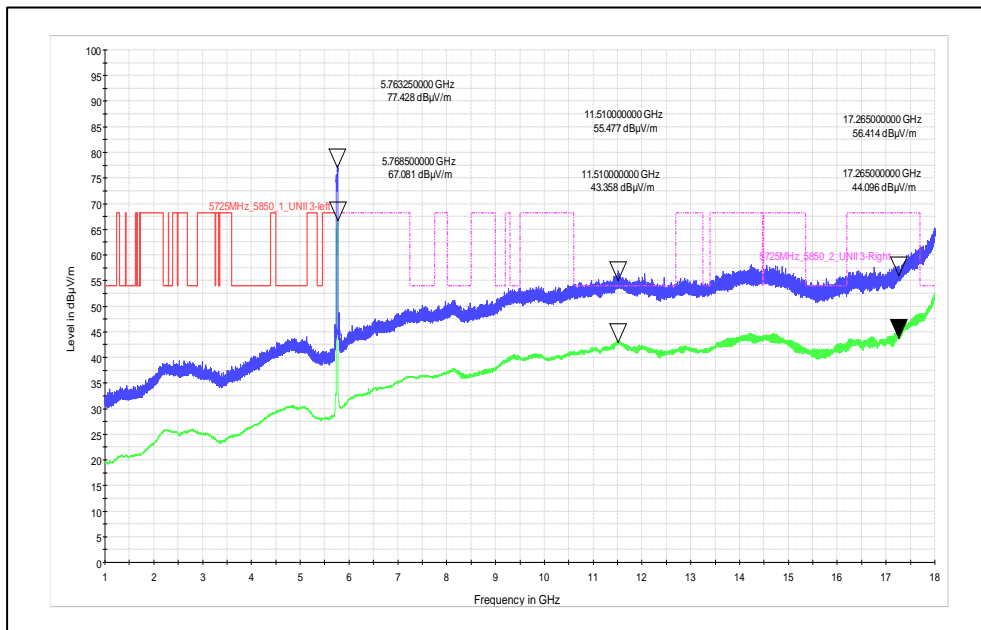

Frequency range: 1GHz-18GHz

Polarization: Horizontal

Modulation : 802.11ac VHT80
Data rate : MCS0

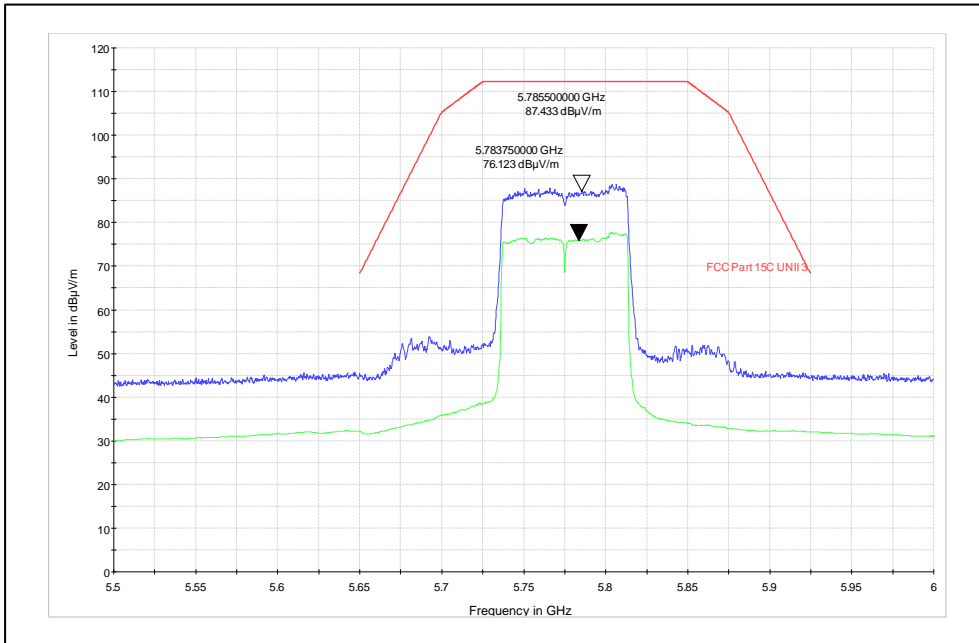

Channel frequency: 5775MHz

Polarization: Vertical

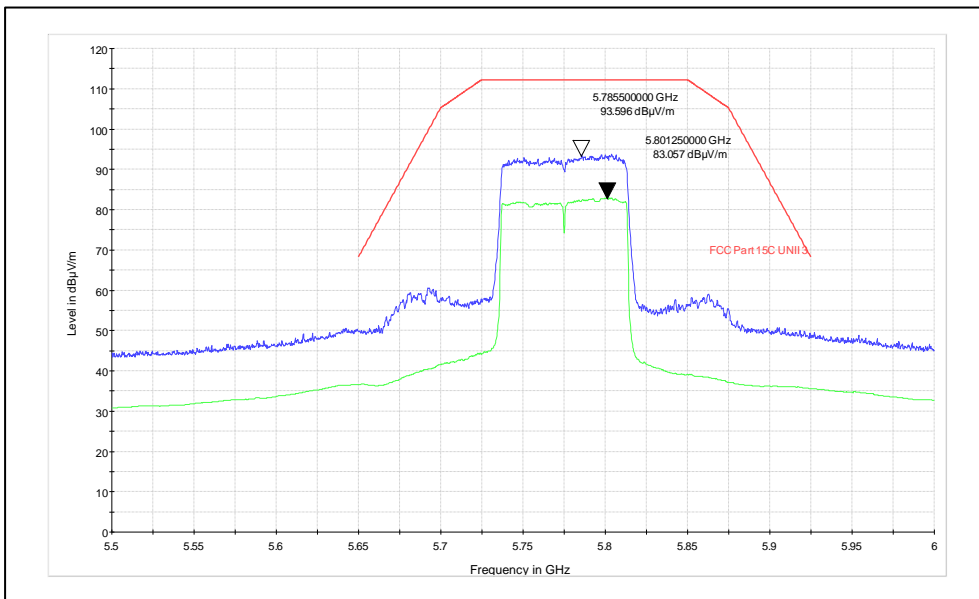

Channel frequency: 5775MHz

Polarization: Horizontal

Channel Frequency: 5775MHz

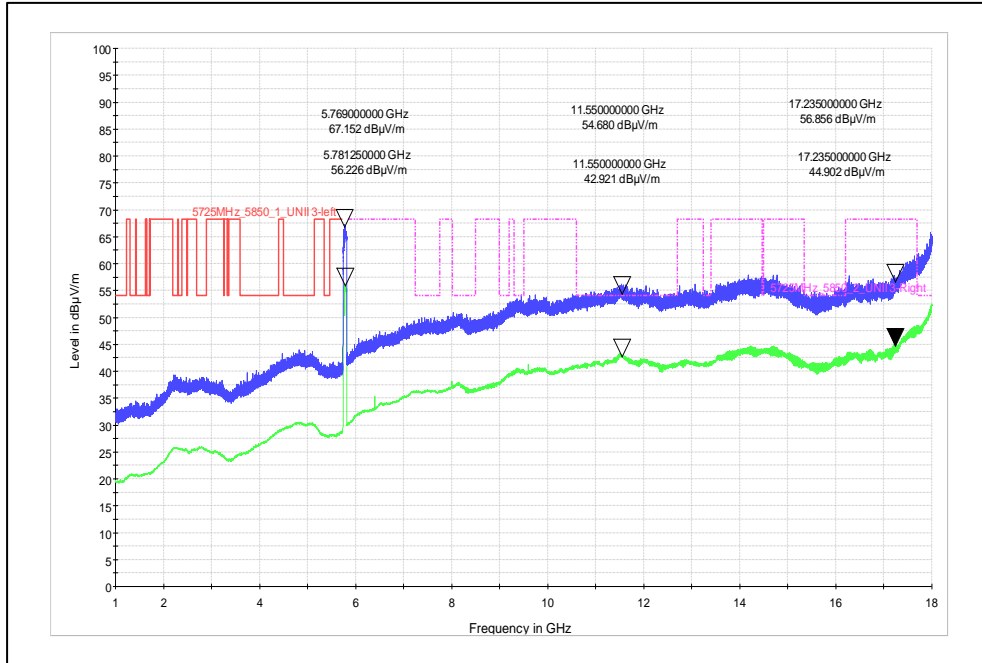

Frequency range: 1GHz-18GHz

Polarization: Vertical

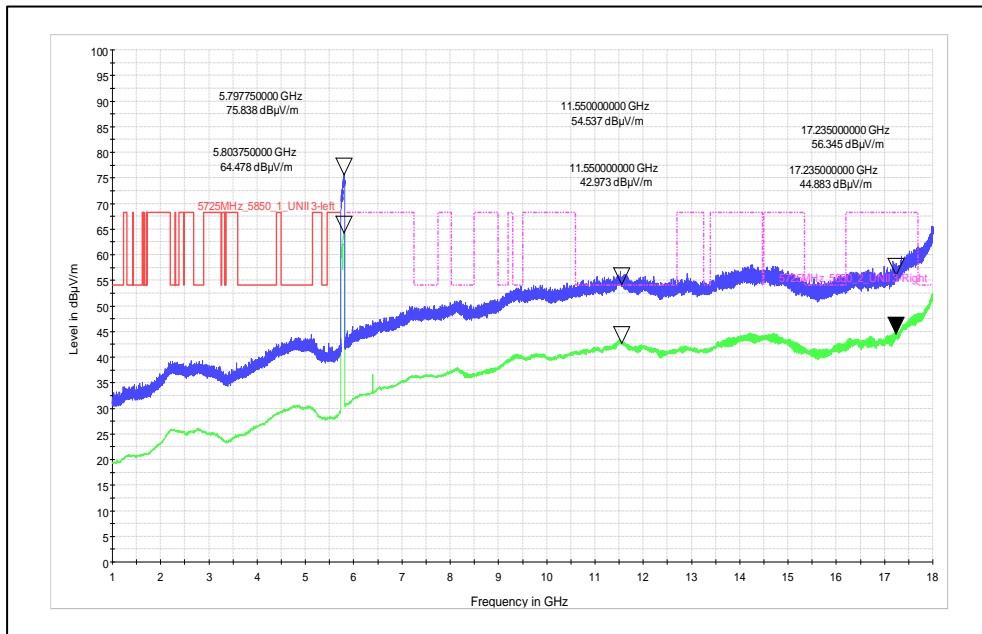

Frequency range: 1GHz-18GHz

Polarization: Horizontal

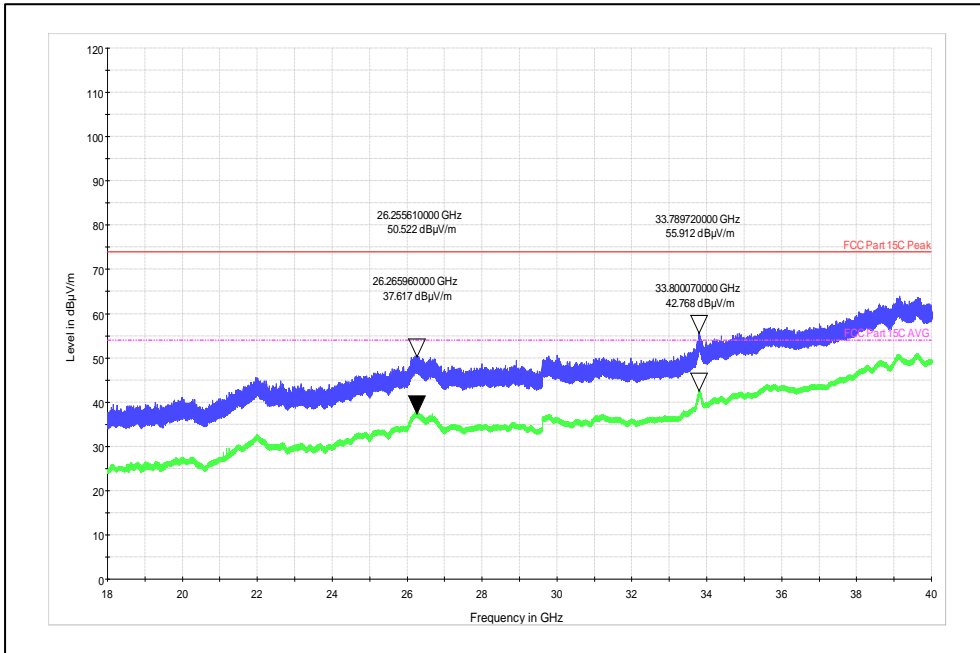

Frequency range: 18GHz-40GHz

Polarization: Vertical

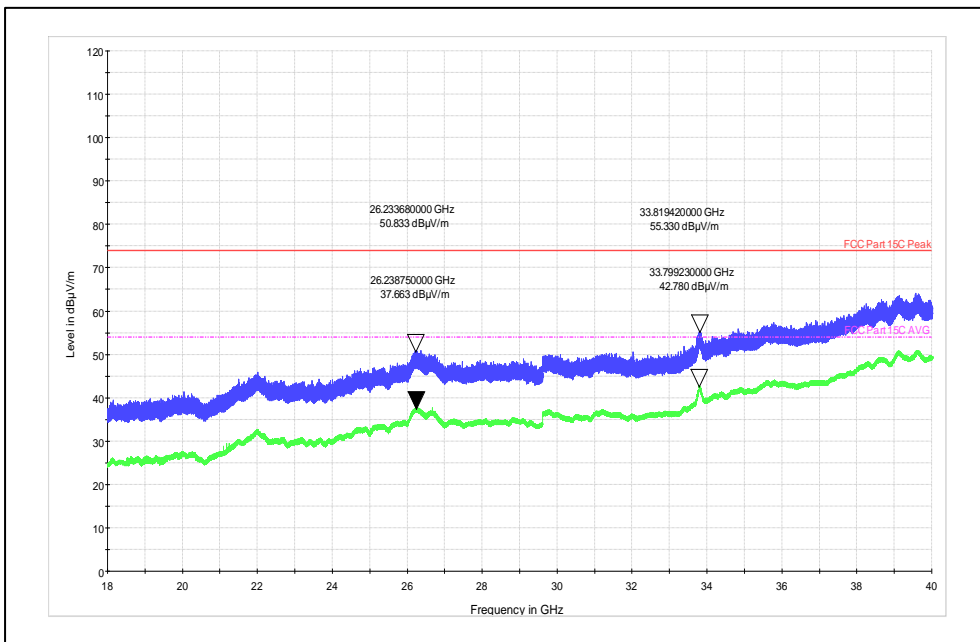

Frequency range: 18GHz-40GHz

Polarization: Horizontal

7.3 Conducted Spurious Emission test on AC Power Line

Result

Pass

Test Specification : FCC Part 15 Section 15.207 / RSS Gen Issue 5 Section 8.8
 Test Method : ANSI C 63.10-2013
 Testing Location : Screened room
 Measurement Bandwidth : 9kHz
 Frequency Range : 150kHz – 30MHz
 Supply Voltage : 110VAC,60Hz
 Test Method : Refer TEST METHODOLOGY

Limits of section 15.207

Frequency of emission (MHz)	Conducted limit (dBµV)	
	Quasi-peak (dBµV)	Average (dBµV)
0.15-0.5	66-56*	56-46*
0.5-5	56	46
5-30	60	50

* Decreases with the logarithm of the frequency

Test Conditions:

Normal Temperature = +24°C Voltage (V norm) = 110V, 60Hz AC through Adapter RH = 64 %

Test result:

Power: 110V 60Hz_LINE

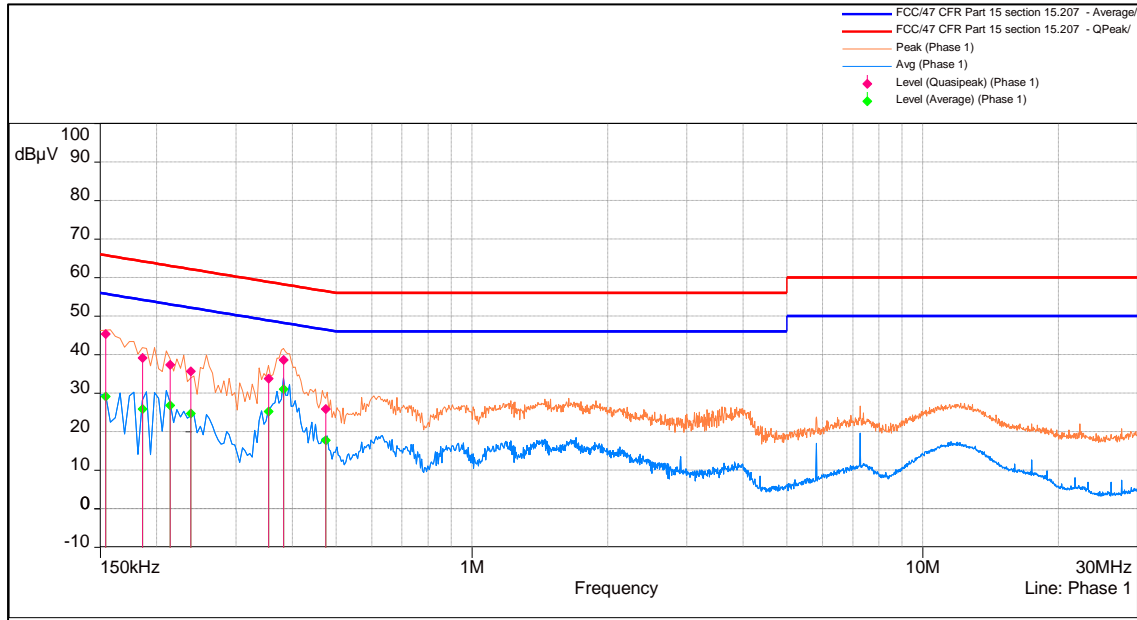

Line Graph

Quasipeak:-

Frequency (MHz)	Correction (dB)	Level (dBµV)	Limit (dBµV)	Margin (dB)	Comments
0.3829	19.58	38.59	58.24	-19.65	Pass
0.15225	19.57	45.34	65.78	-20.44	Pass
0.35465	19.58	33.83	58.87	-25.04	Pass
0.18795	19.57	39.17	64.21	-25.05	Pass
0.21425	19.56	37.42	63.05	-25.63	Pass
0.2373	19.56	35.65	62.17	-26.52	Pass
0.47575	19.61	25.9	56.44	-30.55	Pass

Average:-

Frequency (MHz)	Correction (dB)	Level (dBµV)	Limit (dBµV)	Margin (dB)	Comments
0.3829	19.58	31.01	48.24	-17.22	Pass
0.35465	19.58	25.28	48.87	-23.59	Pass
0.21425	19.56	26.88	53.05	-26.17	Pass
0.15225	19.57	29.16	55.78	-26.63	Pass
0.2373	19.56	24.77	52.17	-27.4	Pass
0.18795	19.57	25.91	54.21	-28.31	Pass
0.47575	19.61	17.82	46.44	-28.62	Pass

Line Table

Power: 110VAC60Hz_NEUTRAL

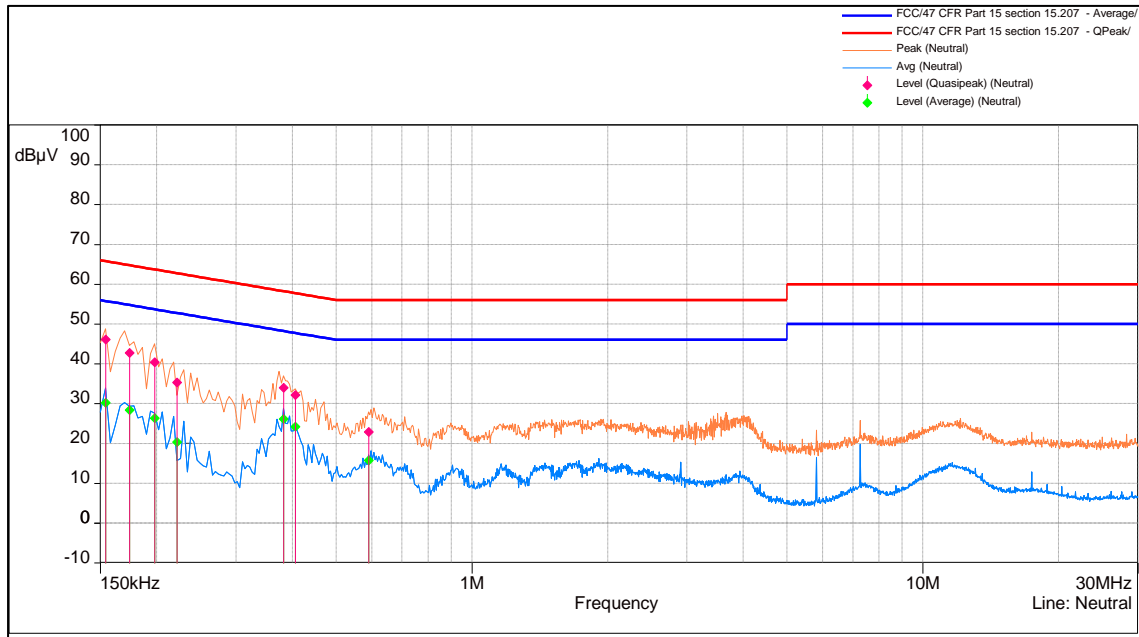

Neutral Graph

Quasipeak:-

Frequency (MHz)	Correction (dB)	Level (dBµV)	Limit (dBµV)	Margin (dB)	Comments
0.1536	19.55	46.14	65.78	-19.65	Pass
0.17595	19.55	42.82	64.77	-21.95	Pass
0.1964	19.55	40.44	63.69	-23.25	Pass
0.38345	19.59	33.96	58.24	-24.27	Pass
0.4072	19.60	32.19	57.73	-25.54	Pass
0.22315	19.55	35.30	62.74	-27.44	Pass
0.58935	19.64	22.92	56.00	-33.08	Pass

Average:-

Frequency (MHz)	Correction (dB)	Level (dBµV)	Limit (dBµV)	Margin (dB)	Comments
0.38345	19.59	26.22	48.24	-22.02	Pass
0.4072	19.6	24.22	47.73	-23.51	Pass
0.1536	19.55	30.28	55.78	-25.51	Pass
0.17595	19.55	28.45	54.77	-26.31	Pass
0.1964	19.55	26.35	53.69	-27.35	Pass
0.58935	19.64	15.82	46.00	-30.18	Pass
0.22315	19.55	20.32	52.74	-32.42	Pass

Neutral Table

8 LIST OF TABLES

Table 1: List of test and measurement instruments	6
Table 2: Instrument application Software versions	7
Table 3: Ratings and System Details as declared by the Client*	8
Table 4: Measurement Uncertainty	9
Table 5: List of Wi-Fi center Frequencies	11
Table 6: Undesirable emission limits	24
Table 7: Transmitter limits for Radiated emission	25

9 Power level used for testing

6Mbps	
5180	17
5200	17
5240	17
5745	7
5785	7
5825	7
HT20_MCS0	
5180	17
5200	17
5240	17
5745	7
5785	7
5825	7
VHT20_MCS0	
5180	17
5200	17
5240	17
5745	7
5785	7
5825	7

HT40_MCS0	
5190	17
5230	17
5755	7
5795	7
VHT40_MCS0	
5190	17
5230	17
5755	7
5795	7

VHT80_MCS0	
5210	17
5775	7

END OF TEST REPORT