

# FCC Radio Test Report

## FCC ID: 2AINY-9028

### Original Grant

**Report No.** : TB-FCC148100  
**Applicant** : Shenzhen iCar multimedia Industry Co., Ltd  
**Equipment Under Test (EUT)**  
**EUT Name** : Action camera  
**Model No.** : 9028  
**Series No.** : 9031, 9032, 9035, 9022, 9180, 9029, 9300, 9500, 9057, 9058  
**Brand Name** : iCar  
**Receipt Date** : 2016-05-23  
**Test Date** : 2016-05-24 to 2016-06-01  
**Issue Date** : 2016-06-02  
**Standards** : FCC Part 15, Subpart C (15.247:2015)  
**Test Method** : ANSI C63.10: 2013  
**Conclusions** : **PASS**

In the configuration tested, the EUT complied with the standards specified above,

The EUT technically complies with the FCC and IC requirements

**Test/Witness Engineer** :

*Iwan Su*

**Approved & Authorized** :

*Ray*

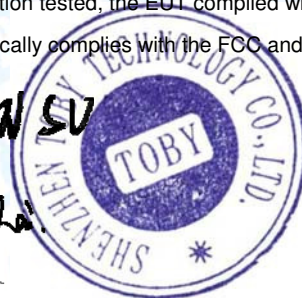

This report details the results of the testing carried out on one sample. The results contained in this test report do not relate to other samples of the same product. The manufacturer should ensure that all products in series production are in conformity with the product sample detailed in the report.

---

---

# Contents

**CONTENTS.....2**

**1. GENERAL INFORMATION ABOUT EUT .....4**

1.1 Client Information.....4

1.2 General Description of EUT (Equipment Under Test) .....4

1.3 Block Diagram Showing the Configuration of System Tested.....5

1.4 Description of Support Units .....5

1.5 Description of Test Mode.....6

1.6 Description of Test Software Setting .....7

1.7 Measurement Uncertainty .....7

1.7 Test Facility.....8

**2. TEST SUMMARY .....9**

**3. TEST EQUIPMENT.....10**

**4. CONDUCTED EMISSION TEST .....12**

4.1 Test Standard and Limit.....12

4.2 Test Setup.....12

4.3 Test Procedure.....12

4.4 EUT Operating Mode .....13

4.5 Test Data.....13

**5. RADIATED EMISSION TEST .....18**

5.1 Test Standard and Limit.....18

5.2 Test Setup.....19

5.3 Test Procedure.....20

5.4 EUT Operating Condition .....20

5.5 Test Data.....21

**6. RESTRICTED BANDS REQUIREMENT .....52**

6.1 Test Standard and Limit.....52

6.2 Test Setup.....52

6.3 Test Procedure.....52

6.4 EUT Operating Condition .....53

6.5 Test Data.....53

**7. BANDWIDTH TEST .....74**

7.1 Test Standard and Limit.....74

7.2 Test Setup.....74

7.3 Test Procedure.....74

7.4 EUT Operating Condition .....74

7.5 Test Data.....75

**8. PEAK OUTPUT POWER TEST.....83**

8.1 Test Standard and Limit.....83

8.2 Test Setup.....	83
8.3 Test Procedure.....	83
8.4 EUT Operating Condition .....	83
8.5 Test Data.....	84
<b>9. POWER SPECTRAL DENSITY TEST .....</b>	<b>87</b>
9.1 Test Standard and Limit.....	87
9.2 Test Setup.....	87
9.3 Test Procedure.....	87
9.4 EUT Operating Condition .....	87
9.5 Test Data.....	88
<b>10. ANTENNA REQUIREMENT.....</b>	<b>96</b>
10.1 Standard Requirement.....	96
10.2 Antenna Connected Construction.....	96

# 1. General Information about EUT

## 1.1 Client Information

**Applicant** : Shenzhen iCar multimedia Industry Co., Ltd  
**Address** : 7F /A Building, HuaYua Industry, Areo, Fenghuang Frist Industry Zoom, Fuyong Stree, Baoan, Shenzhen, China  
**Manufacturer** : Shenzhen iCar multimedia Industry Co., Ltd  
**Address** : 7F /A Building, HuaYua Industry, Areo, Fenghuang Frist Industry Zoom, Fuyong Stree, Baoan, Shenzhen, China

## 1.2 General Description of EUT (Equipment Under Test)

<b>EUT Name</b>	:	Action camera
<b>Models No.</b>	:	9028, 9031, 9032, 9035, 9022, 9180, 9029, 9300, 9500, 9057, 9058
<b>Model Difference</b>	:	All these models are identical in the same PCB, layout and electrical circuit, the only difference is model name for commercial.
<b>Product Description</b>	:	Operation Frequency: 802.11b/g/n(HT20): 2412MHz~2462MHz 802.11n(HT40): 2422MHz~2452MHz
	Number of Channel:	802.11b/g/n(HT20):11 channels <b>see note(3)</b> 802.11n(HT40): 7 channels <b>see note(3)</b>
	RF Output Power:	802.11b: 9.27 dBm 802.11g: 9.18 dBm 802.11n (HT20): 9.08 dBm 802.11n (HT40): 9.06 dBm
	Antenna Gain:	0.44 dBi PCB Antenna
	Modulation Type:	802.11b: DSSS(CCK, QPSK, DBPSK) 802.11g/n: OFDM (64QAM, 16QAM, QPSK, BPSK)
	Bit Rate of Transmitter:	802.11b:11/5.5/2/1 Mbps 802.11g:54/48/36/24/18/12/9/6 Mbps 802.11n:up to 150Mbps
	<b>Power Supply</b>	:
<b>Power Rating</b>	:	DC 5.0V by USB cable. DC 3.7V by 1050mAh Li-ion Battery. AC/DC Adapter: Input:100~240V, 50/60Hz Output:5V, 1A

<b>Connecting I/O Port(S)</b>	:	Please refer to the User's Manual
-------------------------------	---	-----------------------------------

**Note:**

- (1) This Test Report is FCC Part 15.247 for 802.11b/g/n, the test procedure follows the FCC KDB 558074 D01 DTS Meas Guidance v03r05.
- (2) For a more detailed features description, please refer to the manufacturer's specifications or the User's Manual.
- (3) Channel List:

Channel	Frequency (MHz)	Channel	Frequency (MHz)	Channel	Frequency (MHz)
01	2412	05	2432	09	2452
02	2417	06	2437	10	2457
03	2422	07	2442	11	2462
04	2427	08	2447		

- (4) The Antenna information about the equipment is provided by the applicant.

### 1.3 Block Diagram Showing the Configuration of System Tested

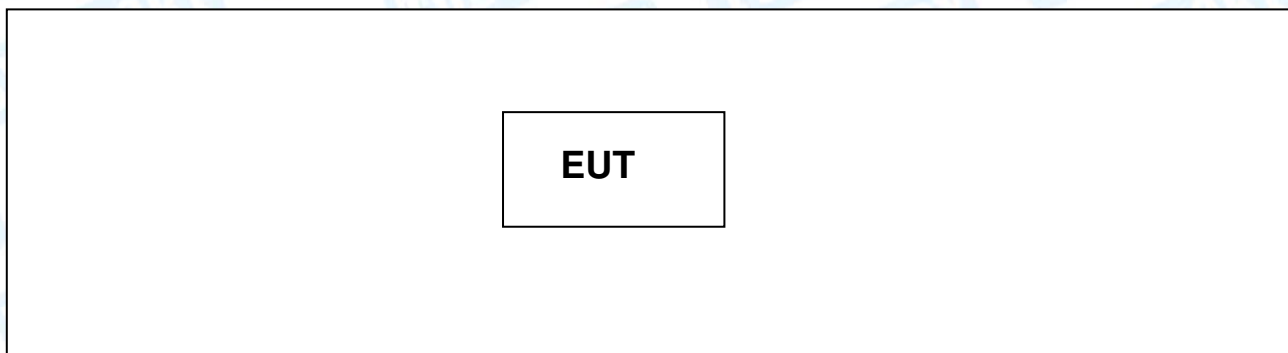
**TX Mode**

### 1.4 Description of Support Units

The EUT has been test as an independent unit

### 1.5 Description of Test Mode

To investigate the maximum EMI emission characteristics generates from EUT, the test system was pre-scanning tested base on the consideration of following EUT operation mode or test configuration mode which possible have effect on EMI emission level. Each of these EUT operation mode(s) or test configuration mode(s) mentioned follow was evaluated respectively.

For Conducted Test	
Final Test Mode	Description
Mode 1	TX B Mode

For Radiated Test	
Final Test Mode	Description
Mode 3	TX Mode B Mode Channel 01/06/11
Mode 4	TX Mode G Mode Channel 01/06/11
Mode 5	TX Mode N(HT20) Mode Channel 01/06/11

**Note:**

- (1) For all test, we have verified the construction and function in typical operation. And all the test modes were carried out with the EUT in transmitting operation in maximum power with all kinds of data rate.  
According to ANSI C63.10 standards, the measurements are performed at the highest, middle, lowest available channels, and the worst case data rate as follows:
  - 802.11b Mode: CCK (1 Mbps)
  - 802.11g Mode: OFDM (6 Mbps)
  - 802.11n (HT20) Mode: MCS 0 (6.5 Mbps)
  - 802.11n (HT40) Mode: MCS 0 (13 Mbps)
- (2) During the testing procedure, the continuously transmitting with the maximum power mode was programmed by the customer.
- (3) The EUT is considered a mobile unit; in normal use it was positioned on X-plane. The worst case was found positioned on X-plane. Therefore only the test data of this X-plane was used for radiated emission measurement test.

## 1.6 Description of Test Software Setting

During testing channel & Power controlling software provided by the customer was used to control the operating channel as well as the output power level. The RF output power selection is for the setting of RF output power expected by the customer and is going to be fixed on the firmware of the final end product power parameters of WLAN.

Test Software Version	N/A		
Channel	CH 01	CH 06	CH 11
IEEE 802.11b DSSS	DEF	DEF	DEF
IEEE 802.11g OFDM	DEF	DEF	DEF
IEEE 802.11n (HT20)	DEF	DEF	DEF

## 1.7 Measurement Uncertainty

The reported uncertainty of measurement  $y \pm U$ , where expanded uncertainty  $U$  is based on a standard uncertainty multiplied by a coverage factor of  $k=2$ , providing a level of confidence of approximately 95 %.

Test Item	Parameters	Expanded Uncertainty ( $U_{Lab}$ )
Conducted Emission	Level Accuracy: 9kHz~150kHz	$\pm 3.42$ dB
	150kHz to 30MHz	$\pm 3.42$ dB
Radiated Emission	Level Accuracy: 9kHz to 30 MHz	$\pm 4.60$ dB
Radiated Emission	Level Accuracy: 30MHz to 1000 MHz	$\pm 4.40$ dB
Radiated Emission	Level Accuracy: Above 1000MHz	$\pm 4.20$ dB

## 1.7 Test Facility

The testing report were performed by the Shenzhen Toby Technology Co., Ltd., in their facilities located at 1A/F., Bldg.6, Yusheng Industrial Zone, The National Road No.107 Xixiang Section 467, Xixiang, Bao'an, Shenzhen, Guangdong, China. At the time of testing, the following bodies accredited the Laboratory:

### **CNAS (L5813)**

The Laboratory has been accredited by CNAS to ISO/IEC 17025: 2005 General Requirements for the Competence of Testing and Calibration Laboratories for the competence in the field of testing. And the Registration No.: CNAS L5813.

### **FCC List No.: (811562)**

The Laboratory is listed in the United States of American Federal Communications Commission (FCC), and the registration number is 811562.

### **IC Registration No.: (11950A-1)**

The Laboratory has been registered by Certification and Engineering Bureau of Industry Canada for radio equipment testing. The site registration: Site# 11950A-1.

## 2. Test Summary

FCC Part 15 Subpart C(15.247)/ RSS 247 Issue 1				
Standard Section		Test Item	Judgment	Remark
FCC	IC			
15.203	/	Antenna Requirement	PASS	N/A
15.207	RSS-GEN 7.2.4	Conducted Emission	PASS	N/A
15.205	RSS-GEN 7.2.2	Restricted Bands	PASS	N/A
15.247(a)(2)	RSS 247 5.2 (1)	6dB Bandwidth	PASS	N/A
15.247(b)	RSS 247 5.4 (4)	Peak Output Power	PASS	N/A
15.247(e)	RSS 247 5.2 (2)	Power Spectral Density	PASS	N/A
15.247(d)	RSS 247 5.5	Transmitter Radiated Spurious Emission	PASS	N/A

**Note:** “/” for no requirement for this test item.  
N/A is an abbreviation for Not Applicable.

### 3. Test Equipment

Conducted Emission Test					
Equipment	Manufacturer	Model No.	Serial No.	Last Cal.	Cal. Due Date
EMI Test Receiver	Rohde & Schwarz	ESCI	100321	Aug. 07, 2015	Aug. 06, 2016
RF Switching Unit	Compliance Direction Systems Inc	RSU-A4	34403	Aug. 07, 2015	Aug. 06, 2016
AMN	SCHWARZBECK	NNBL 8226-2	8226-2/164	Aug. 07, 2015	Aug. 06, 2016
LISN	Rohde & Schwarz	ENV216	101131	Aug. 08, 2015	Aug. 07, 2016
Radiation Emission Test					
Equipment	Manufacturer	Model No.	Serial No.	Last Cal.	Cal. Due Date
Spectrum Analyzer	Agilent	E4407B	MY45106456	Aug. 07, 2015	Aug. 06, 2016
EMI Test Receiver	Rohde & Schwarz	ESCI	100010/007	Aug. 07, 2015	Aug. 06, 2016
Bilog Antenna	ETS-LINDGREN	3142E	00117537	Mar. 26, 2016	Mar. 25, 2017
Bilog Antenna	ETS-LINDGREN	3142E	00117542	Mar. 26, 2016	Mar. 25, 2017
Horn Antenna	ETS-LINDGREN	3117	00143207	Mar. 26, 2016	Mar. 25, 2017
Horn Antenna	ETS-LINDGREN	3117	00143209	Mar. 26, 2016	Mar. 25, 2017
Pre-amplifier	Sonoma	310N	185903	Mar. 26, 2016	Mar. 25, 2017
Pre-amplifier	HP	8447B	3008A00849	Mar. 26, 2016	Mar. 25, 2017
Cable	HUBER+SUHNER	100	SUCOFLEX	Mar. 26, 2016	Mar. 25, 2017
Positioning Controller	ETS-LINDGREN	2090	N/A	N/A	N/A
Antenna Conducted Emission					
Equipment	Manufacturer	Model No.	Serial No.	Last Cal.	Cal. Due Date
Spectrum Analyzer	Agilent	E4407B	MY45106456	Aug. 07, 2015	Aug. 06, 2016
EMI Test Receiver	Rohde & Schwarz	ESCI	100010/007	Aug. 07, 2015	Aug. 06, 2016
Power Meter	Anritsu	ML2495A	25406005	Aug.07, 2015	Aug.06, 2016
Power Sensor	Anritsu	ML2411B	25406005	Aug.07, 2015	Aug.06, 2016



## 4. Conducted Emission Test

### 4.1 Test Standard and Limit

4.1.1 Test Standard  
FCC Part 15.207

4.1.2 Test Limit

**Conducted Emission Test Limit**

Frequency	Maximum RF Line Voltage (dB $\mu$ V)	
	Quasi-peak Level	Average Level
150kHz~500kHz	66 ~ 56 *	56 ~ 46 *
500kHz~5MHz	56	46
5MHz~30MHz	60	50

Notes:

- (1) \*Decreasing linearly with logarithm of the frequency.
- (2) The lower limit shall apply at the transition frequencies.
- (3) The limit decrease in line with the logarithm of the frequency in the range of 0.15 to 0.50MHz.

### 4.2 Test Setup

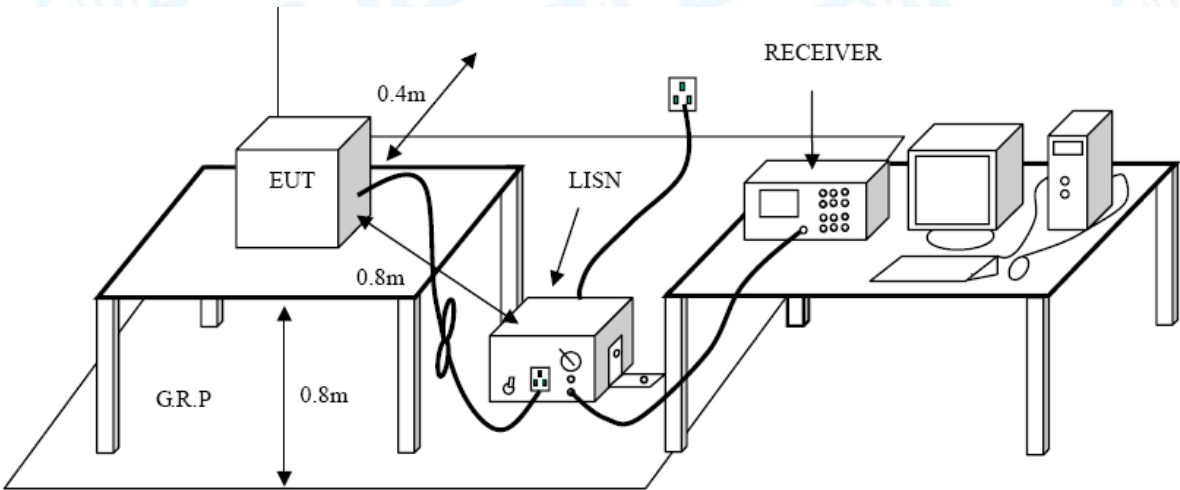

### 4.3 Test Procedure

The EUT was placed 0.8 meters from the horizontal ground plane with EUT being connected to the power mains through a line impedance stabilization network (LISN). All other support equipments powered from additional LISN(s). The LISN provide 50 Ohm/ 50uH of coupling impedance for the measuring instrument.

Interconnecting cables that hang closer than 40 cm to the ground plane shall be folded back and forth in the center forming a bundle 30 to 40 cm long.

I/O cables that are not connected to a peripheral shall be bundled in the center. The end of the cable may be terminated, if required, using the correct terminating impedance. The overall length shall not exceed 1 m.

LISN at least 80 cm from nearest part of EUT chassis.

The bandwidth of EMI test receiver is set at 9kHz, and the test frequency band is from 0.15MHz to 30MHz.

#### 4.4 EUT Operating Mode

Please refer to the description of test mode.

#### 4.5 Test Data

Please see the next page.

<b>EUT:</b>	Action camera	<b>Model Name :</b>	9028
<b>Temperature:</b>	25 °C	<b>Relative Humidity:</b>	55%
<b>Test Voltage:</b>	AC 120V/60Hz		
<b>Terminal:</b>	Line		
<b>Test Mode:</b>	TX B Mode		
<b>Remark:</b>	Only worse case is reported		

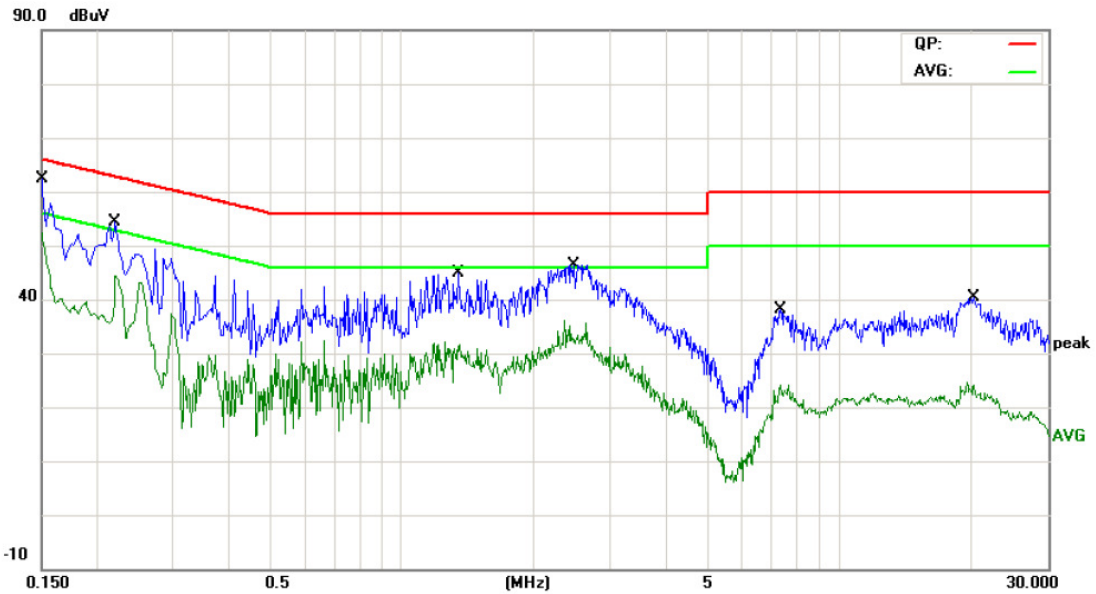

No.	Mk.	Freq. MHz	Reading Level dBuV	Correct Factor dB	Measure- ment dBuV	Limit dBuV	Over dB	Detector
1		0.1499	52.20	10.12	62.32	66.00	-3.68	QP
2	*	0.1499	42.32	10.12	52.44	56.00	-3.56	AVG
3		0.2220	44.25	10.11	54.36	62.74	-8.38	QP
4		0.2220	34.38	10.11	44.49	52.74	-8.25	AVG
5		1.3500	34.82	10.13	44.95	56.00	-11.05	QP
6		1.3500	21.25	10.13	31.38	46.00	-14.62	AVG
7		2.4660	36.35	10.06	46.41	56.00	-9.59	QP
8		2.4660	23.43	10.06	33.49	46.00	-12.51	AVG
9		7.3539	28.03	10.07	38.10	60.00	-21.90	QP
10		7.3539	14.01	10.07	24.08	50.00	-25.92	AVG
11		20.2860	30.36	10.06	40.42	60.00	-19.58	QP
12		20.2860	14.00	10.06	24.06	50.00	-25.94	AVG

\*:Maximum data    x:Over limit    !:over margin

**Emission Level= Read Level+ Correct Factor**

<b>EUT:</b>	Action camera	<b>Model Name :</b>	9028
<b>Temperature:</b>	25 °C	<b>Relative Humidity:</b>	55%
<b>Test Voltage:</b>	AC 120V/60Hz		
<b>Terminal:</b>	Neutral		
<b>Test Mode:</b>	TX B Mode		
<b>Remark:</b>	Only worse case is reported		

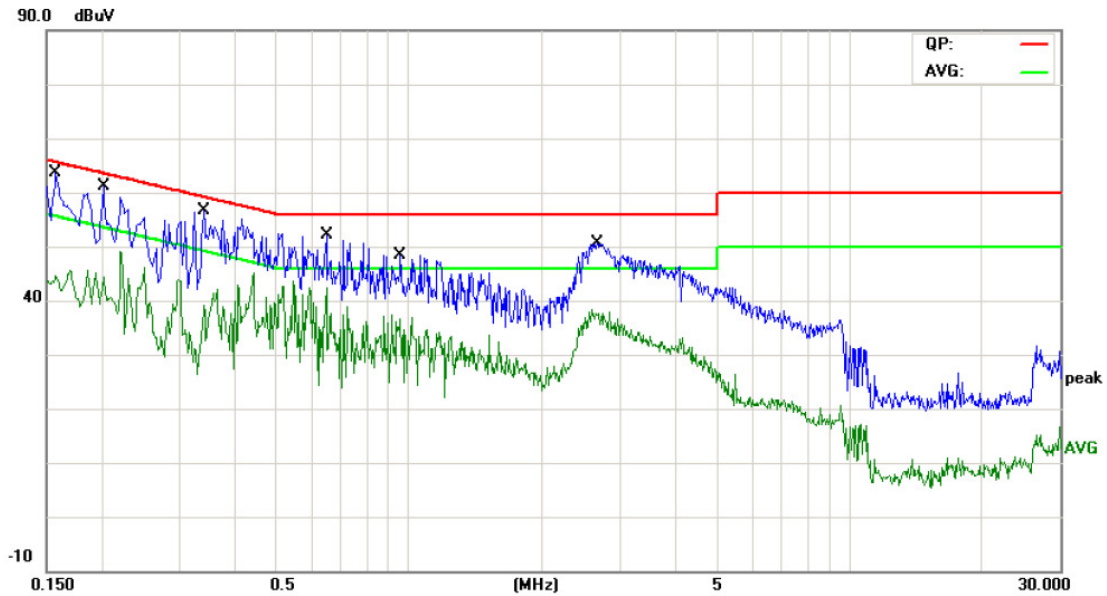

No.	Mk.	Freq. MHz	Reading Level dBuV	Correct Factor dB	Measure- ment dBuV	Limit dBuV	Over dB	Detector
1	*	0.1580	53.45	10.12	63.57	65.56	-1.99	QP
2		0.1580	34.40	10.12	44.52	55.56	-11.04	AVG
3		0.2020	50.95	10.12	61.07	63.52	-2.45	QP
4		0.2020	34.26	10.12	44.38	53.52	-9.14	AVG
5		0.3420	46.44	10.07	56.51	59.15	-2.64	QP
6		0.3420	29.18	10.07	39.25	49.15	-9.90	AVG
7		0.6500	42.19	10.02	52.21	56.00	-3.79	QP
8		0.6500	32.40	10.02	42.42	46.00	-3.58	AVG
9		0.9539	38.34	10.14	48.48	56.00	-7.52	QP
10		0.9539	26.53	10.14	36.67	46.00	-9.33	AVG
11		2.6579	40.50	10.06	50.56	56.00	-5.44	QP
12		2.6579	27.55	10.06	37.61	46.00	-8.39	AVG

\*:Maximum data    x:Over limit    !:over margin

**Emission Level= Read Level+ Correct Factor**

<b>EUT:</b>	Action camera	<b>Model Name :</b>	9028
<b>Temperature:</b>	25 °C	<b>Relative Humidity:</b>	55%
<b>Test Voltage:</b>	AC 240V/60Hz		
<b>Terminal:</b>	Line		
<b>Test Mode:</b>	TX B Mode		
<b>Remark:</b>	Only worse case is reported		

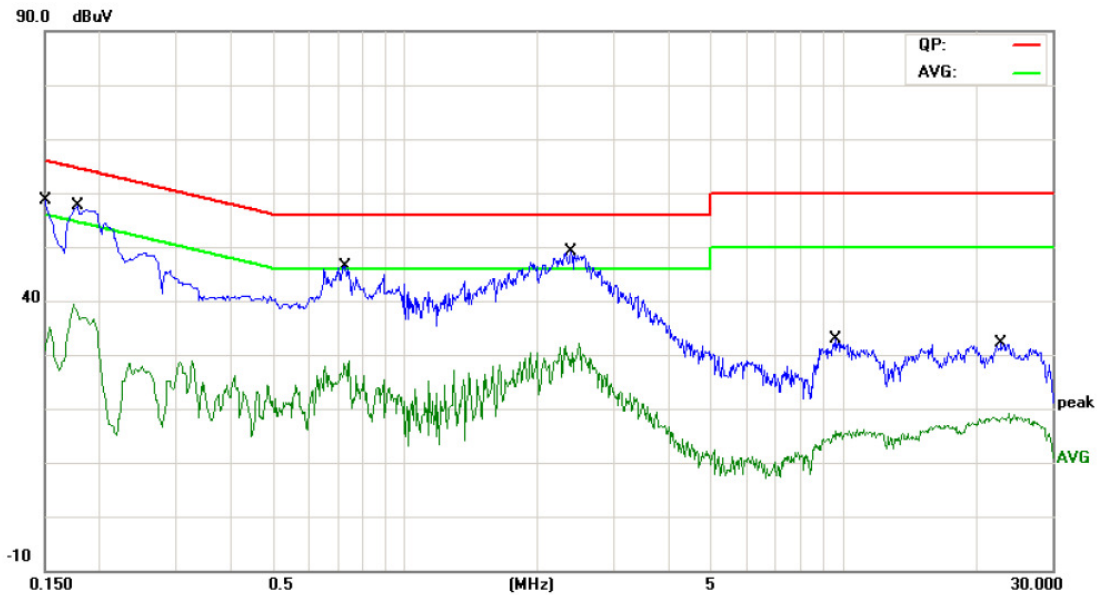

No.	Mk.	Freq. MHz	Reading Level dBuV	Correct Factor dB	Measure- ment dBuV	Limit dBuV	Over dB	Detector
1		0.1499	48.69	9.92	58.61	66.00	-7.39	QP
2		0.1499	21.01	9.92	30.93	56.00	-25.07	AVG
3		0.1785	47.59	9.98	57.57	64.55	-6.98	QP
4		0.1785	27.99	9.98	37.97	54.55	-16.58	AVG
5		0.7300	36.22	10.11	46.33	56.00	-9.67	QP
6		0.7300	16.83	10.11	26.94	46.00	-19.06	AVG
7	*	2.3940	39.00	10.05	49.05	56.00	-6.95	QP
8		2.3940	17.87	10.05	27.92	46.00	-18.08	AVG
9		9.6219	22.65	10.15	32.80	60.00	-27.20	QP
10		9.6219	5.80	10.15	15.95	50.00	-34.05	AVG
11		22.9460	21.96	10.16	32.12	60.00	-27.88	QP
12		22.9460	7.85	10.16	18.01	50.00	-31.99	AVG

\*:Maximum data    x:Over limit    !:over margin

**Emission Level= Read Level+ Correct Factor**

<b>EUT:</b>	Action camera	<b>Model Name :</b>	9028
<b>Temperature:</b>	25 °C	<b>Relative Humidity:</b>	55%
<b>Test Voltage:</b>	AC 240V/60Hz		
<b>Terminal:</b>	Neutral		
<b>Test Mode:</b>	TX B Mode		
<b>Remark:</b>	Only worse case is reported		

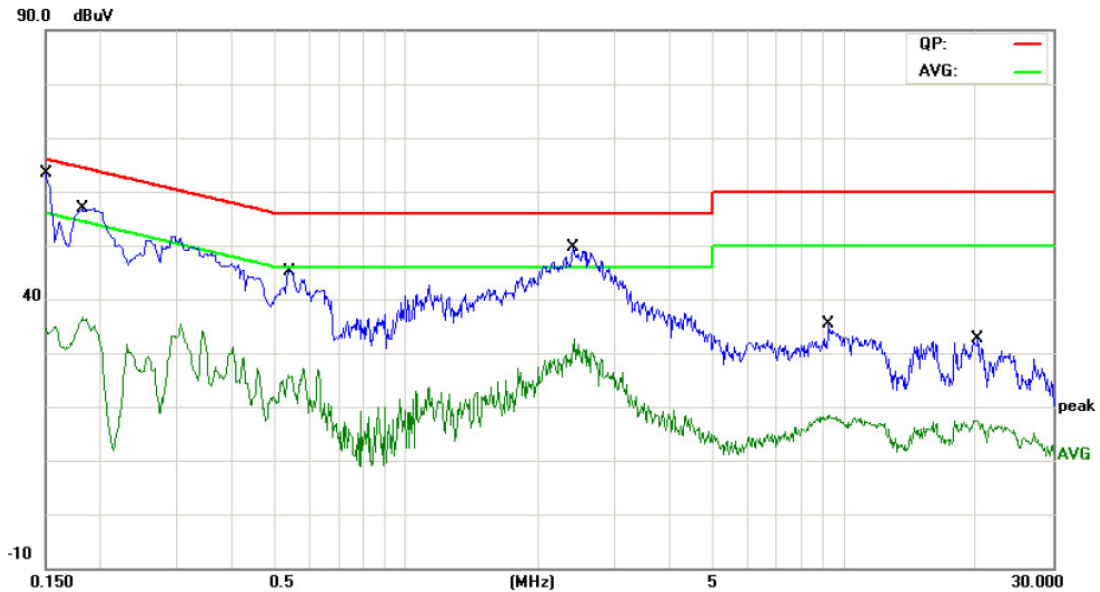

No.	Mk.	Freq.	Reading Level	Correct Factor	Measurement	Limit	Over	Detector
		MHz	dBuV	dB	dBuV	dBuV	dB	
1	*	0.1499	53.13	10.12	63.25	66.00	-2.75	QP
2		0.1499	24.83	10.12	34.95	56.00	-21.05	AVG
3		0.1819	46.71	10.12	56.83	64.39	-7.56	QP
4		0.1819	26.44	10.12	36.56	54.39	-17.83	AVG
5		0.5349	35.24	10.02	45.26	56.00	-10.74	QP
6		0.5349	15.93	10.02	25.95	46.00	-20.05	AVG
7		2.4020	39.64	10.06	49.70	56.00	-6.30	QP
8		2.4020	22.57	10.06	32.63	46.00	-13.37	AVG
9		9.1819	25.15	10.13	35.28	60.00	-24.72	QP
10		9.1819	8.37	10.13	18.50	50.00	-31.50	AVG
11		20.1220	22.61	10.06	32.67	60.00	-27.33	QP
12		20.1220	7.43	10.06	17.49	50.00	-32.51	AVG

\*:Maximum data    x:Over limit    !:over margin

**Emission Level= Read Level+ Correct Factor**

## 5. Radiated Emission Test

### 5.1 Test Standard and Limit

5.1.1 Test Standard  
FCC Part 15.209

5.1.2 Test Limit

**Radiated Emission Limits (9kHz~1000MHz)**

Frequency (MHz)	Field Strength (microvolt/meter)	Measurement Distance (meters)
0.009~0.490	2400/F(KHz)	300
0.490~1.705	24000/F(KHz)	30
1.705~30.0	30	30
30~88	100	3
88~216	150	3
216~960	200	3
Above 960	500	3

**Radiated Emission Limit (Above 1000MHz)**

Frequency (MHz)	Class A (dBuV/m)(at 3 M)		Class B (dBuV/m)(at 3 M)	
	Peak	Average	Peak	Average
Above 1000	80	60	74	54

**Note:**

- (1) The tighter limit applies at the band edges.
- (2) Emission Level(dBuV/m)=20log Emission Level(uV/m)

### 5.2 Test Setup

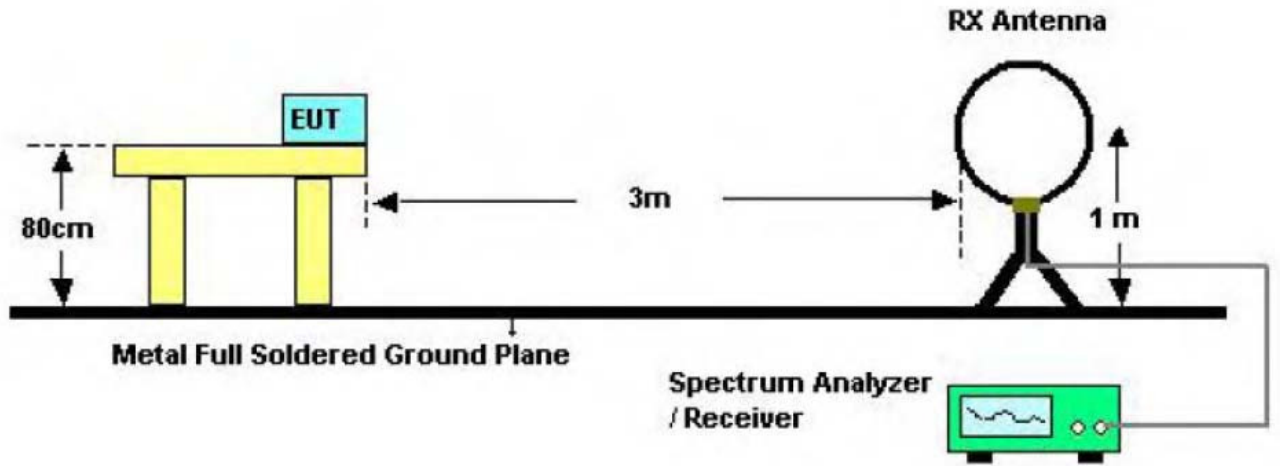

### Below 30MHz Test Setup

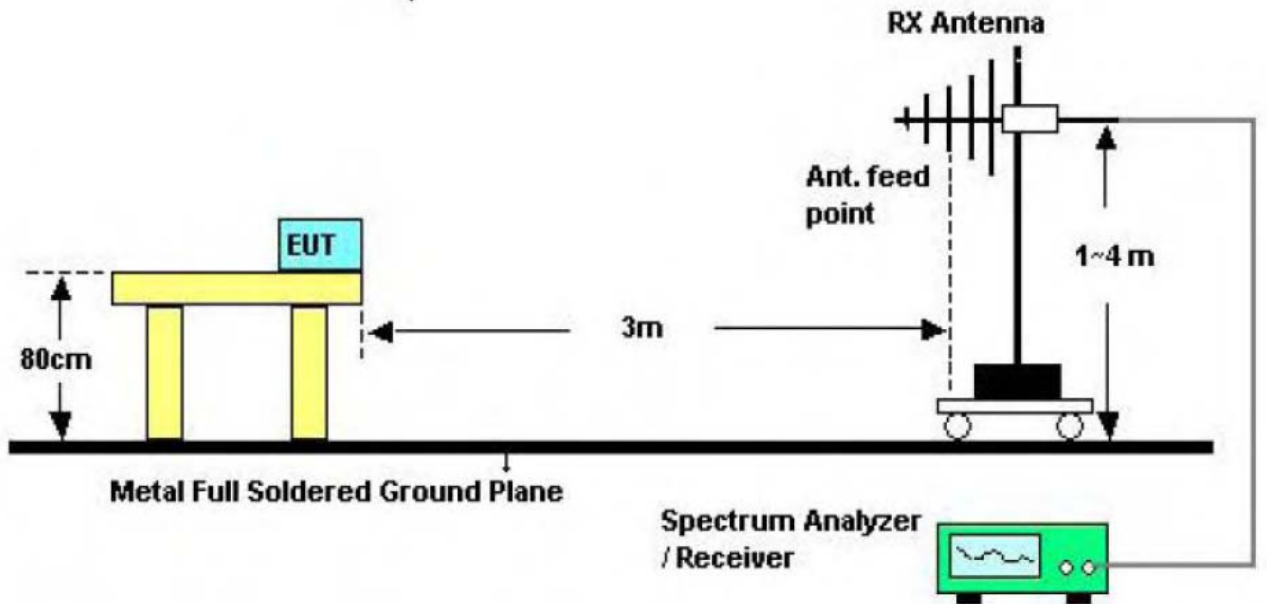

### Below 1000MHz Test Setup

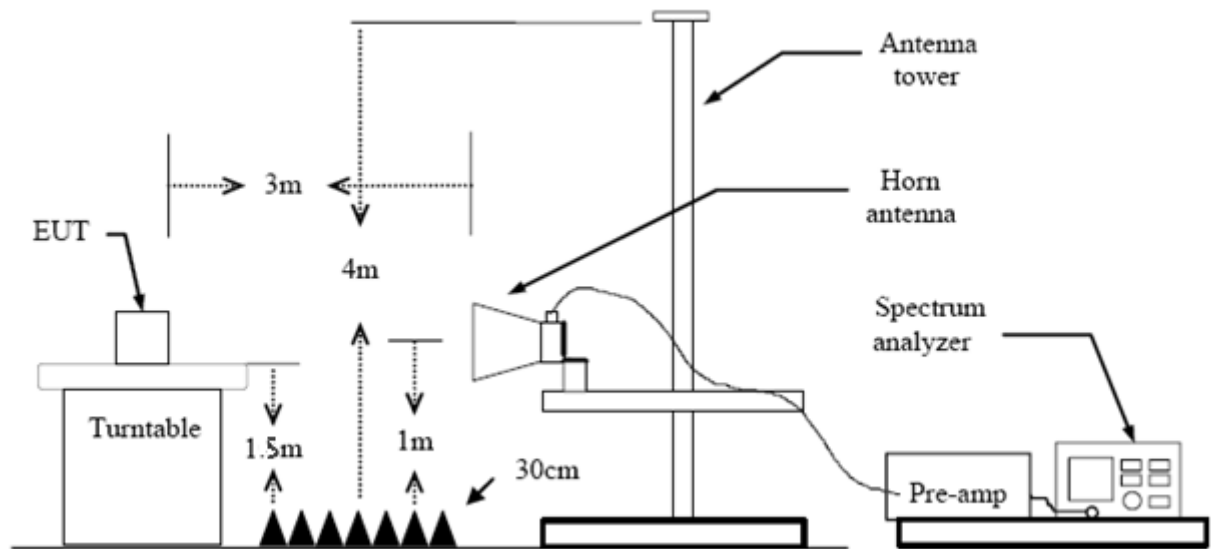

Above 1GHz Test Setup

### 5.3 Test Procedure

- (1) Measurements at frequency above 1GHz. The EUT was placed on a rotating 1.5m high above the ground. RF absorbers covered the ground plane with a minimum area of 3.0m by 3.0m between the EUT and measurement receiver antenna. The RF absorber shall not exceed 30cm in high above the conducting floor. The table was rotated 360 degrees to determine the position of the highest radiation.
- (2) The Test antenna shall vary between 1m and 4m, Both Horizontal and Vertical antenna are set to make measurement.
- (3) The initial step in collecting conducted emission data is a spectrum analyzer peak detector mode pre-scanning the measurement frequency range. Significant peaks are then marked and then Quasi Peak detector mode re-measured.
- (4) If the Peak Mode measured value compliance with and lower than Quasi Peak Mode Limit Bellow 1 GHz, the EUT shall be deemed to meet QP Limits and then no additional QP Mode measurement performed. But the Peak Value and average value both need to comply with applicable limit above 1 GHz.
- (5) Testing frequency range below 1GHz the measuring instrument use VBW=120 kHz with Quasi-peak detection.
- (6) Testing frequency range above 1GHz the measuring instrument use RBW=1 MHz and VBW=3 MHz with Peak Detector for Peak Values, and use RBW=1 MHz and VBW=10 Hz with Peak Detector for Average Values.
- (7) For the actual test configuration, please see the test setup photo.

### 5.4 EUT Operating Condition

The Equipment Under Test was set to Continual Transmitting in maximum power.

## 5.5 Test Data

Remark: During testing above 1GHz the measuring instrument use RBW=1 MHz and VBW=3 MHz with Peak Detector for Peak Values, and use RBW=1 MHz and VBW=10 Hz with Peak Detector for Average Values.

Test data please refer the following pages.

<b>EUT:</b>	Action camera	<b>Model:</b>	9028
<b>Temperature:</b>	25 °C	<b>Relative Humidity:</b>	55%
<b>Test Voltage:</b>	DC 3.7V		
<b>Ant. Pol.</b>	Horizontal		
<b>Test Mode:</b>	TX B Mode 2412MHz		
<b>Remark:</b>	Only worse case is reported		

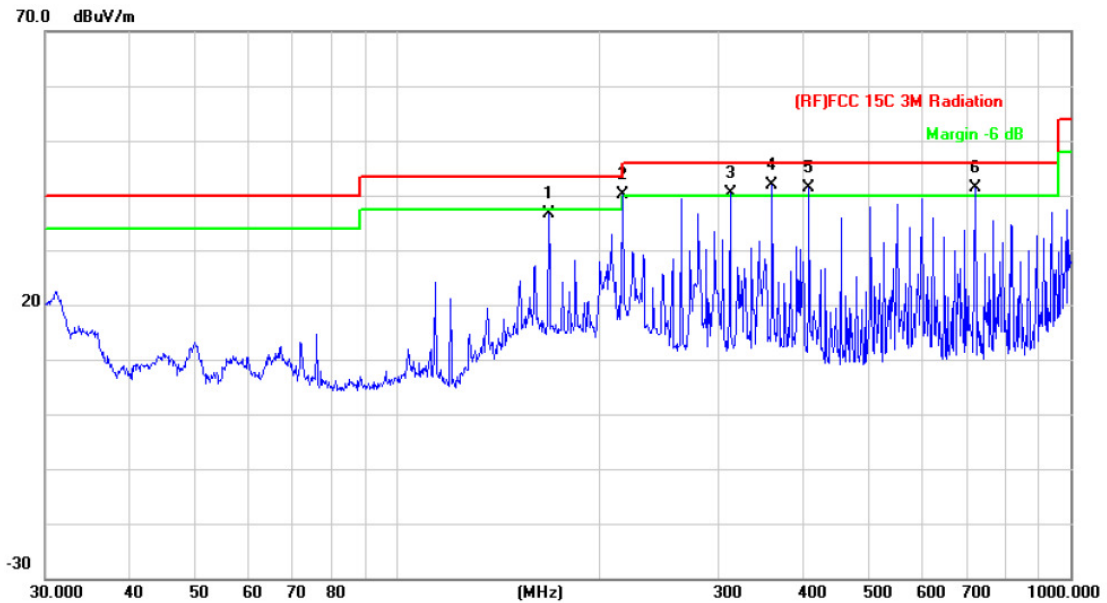

No.	Mk.	Freq. MHz	Reading Level dBuV	Correct Factor dB/m	Measure- ment dBuV/m	Limit dBuV/m	Over dB	Detector
1		167.8240	57.66	-21.04	36.62	43.50	-6.88	peak
2	!	216.0240	59.95	-19.70	40.25	46.00	-5.75	peak
3	!	312.1792	57.00	-16.63	40.37	46.00	-5.63	peak
4	*	360.4476	56.35	-14.55	41.80	46.00	-4.20	peak
5	!	408.9460	54.19	-12.84	41.35	46.00	-4.65	peak
6	!	721.7259	48.51	-7.10	41.41	46.00	-4.59	peak

\*:Maximum data    x:Over limit    !:over margin

**Emission Level= Read Level+ Correct Factor**

<b>EUT:</b>	Action camera	<b>Model:</b>	9028
<b>Temperature:</b>	25 °C	<b>Relative Humidity:</b>	55%
<b>Test Voltage:</b>	DC 3.7V		
<b>Ant. Pol.</b>	Vertical		
<b>Test Mode:</b>	TX B Mode 2412MHz		
<b>Remark:</b>	Only worse case is reported		

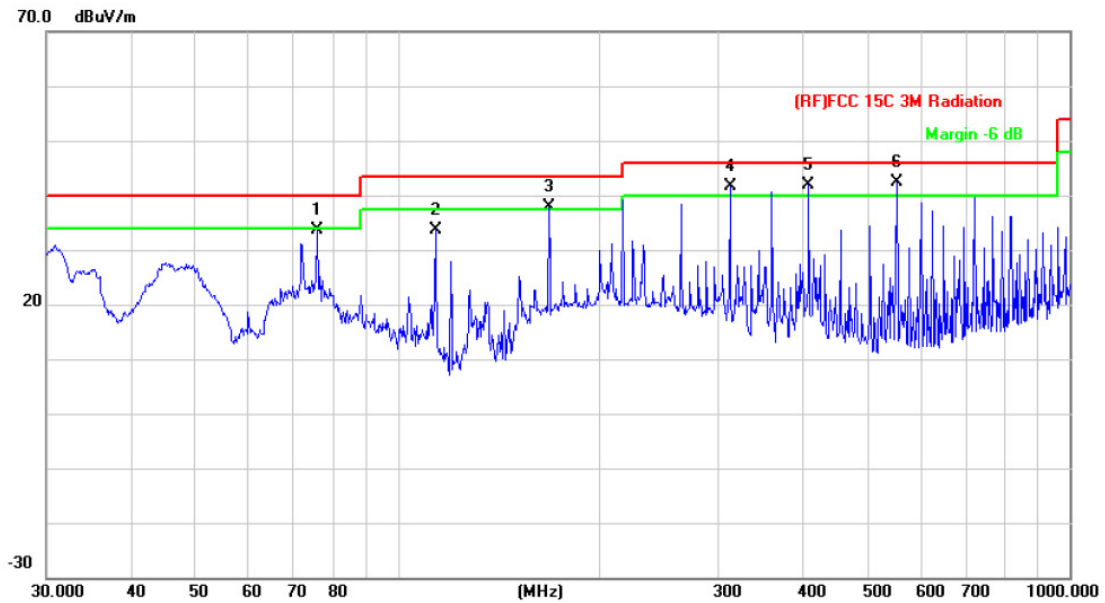

No.	Mk.	Freq. MHz	Reading Level dBuV	Correct Factor dB/m	Measure- ment dBuV/m	Limit dBuV/m	Over dB	Detector
1		75.9770	56.96	-23.42	33.54	40.00	-6.46	peak
2		113.7142	55.84	-22.11	33.73	43.50	-9.77	peak
3	!	167.8240	58.99	-21.04	37.95	43.50	-5.55	peak
4	!	312.1792	58.32	-16.63	41.69	46.00	-4.31	peak
5	!	408.9460	54.81	-12.84	41.97	46.00	-4.03	peak
6	*	552.8831	52.56	-10.13	42.43	46.00	-3.57	peak

\*:Maximum data x:Over limit !:over margin

**Emission Level= Read Level+ Correct Factor**

<b>EUT:</b>	Action camera	<b>Model:</b>	9028
<b>Temperature:</b>	25 °C	<b>Relative Humidity:</b>	55%
<b>Test Voltage:</b>	DC 3.7V		
<b>Ant. Pol.</b>	Horizontal		
<b>Test Mode:</b>	TX B Mode 2437MHz		
<b>Remark:</b>	Only worse case is reported		

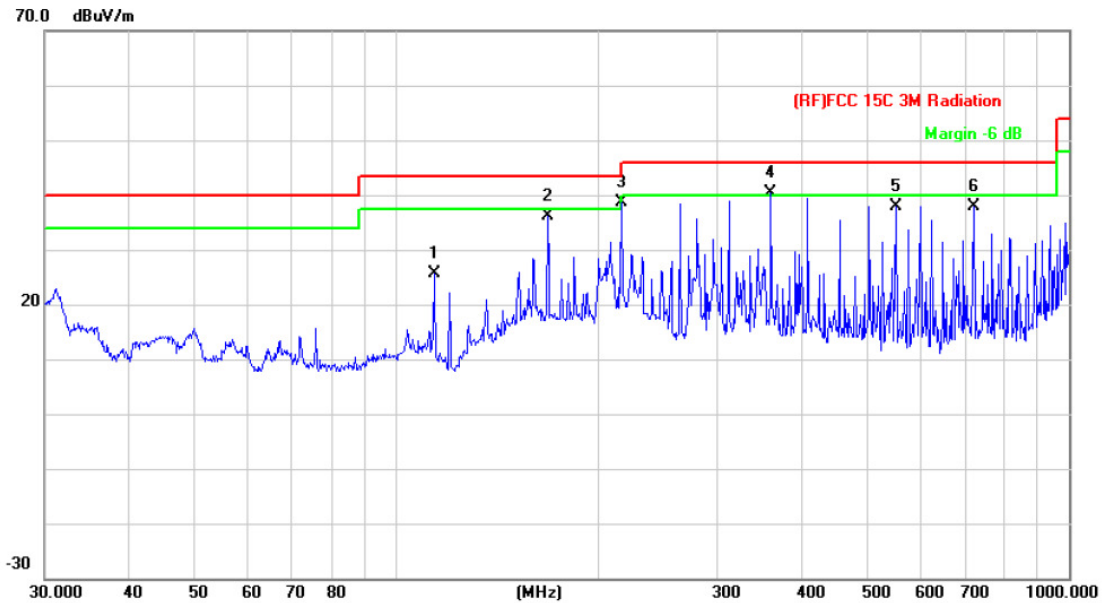

No.	Mk.	Freq. MHz	Reading Level dBuV	Correct Factor dB/m	Measure- ment dBuV/m	Limit dBuV/m	Over dB	Detector
1		113.7142	47.66	-22.11	25.55	43.50	-17.95	peak
2		167.8240	57.16	-21.04	36.12	43.50	-7.38	peak
3		216.0240	58.45	-19.70	38.75	46.00	-7.25	peak
4	*	360.4476	54.85	-14.55	40.30	46.00	-5.70	peak
5		552.8831	48.12	-10.13	37.99	46.00	-8.01	peak
6		721.7259	45.01	-7.10	37.91	46.00	-8.09	peak

\*:Maximum data x:Over limit !:over margin

**Emission Level= Read Level+ Correct Factor**

<b>EUT:</b>	Action camera	<b>Model:</b>	9028
<b>Temperature:</b>	25 °C	<b>Relative Humidity:</b>	55%
<b>Test Voltage:</b>	DC 3.7V		
<b>Ant. Pol.</b>	Vertical		
<b>Test Mode:</b>	TX B Mode 2437MHz		
<b>Remark:</b>	Only worse case is reported		

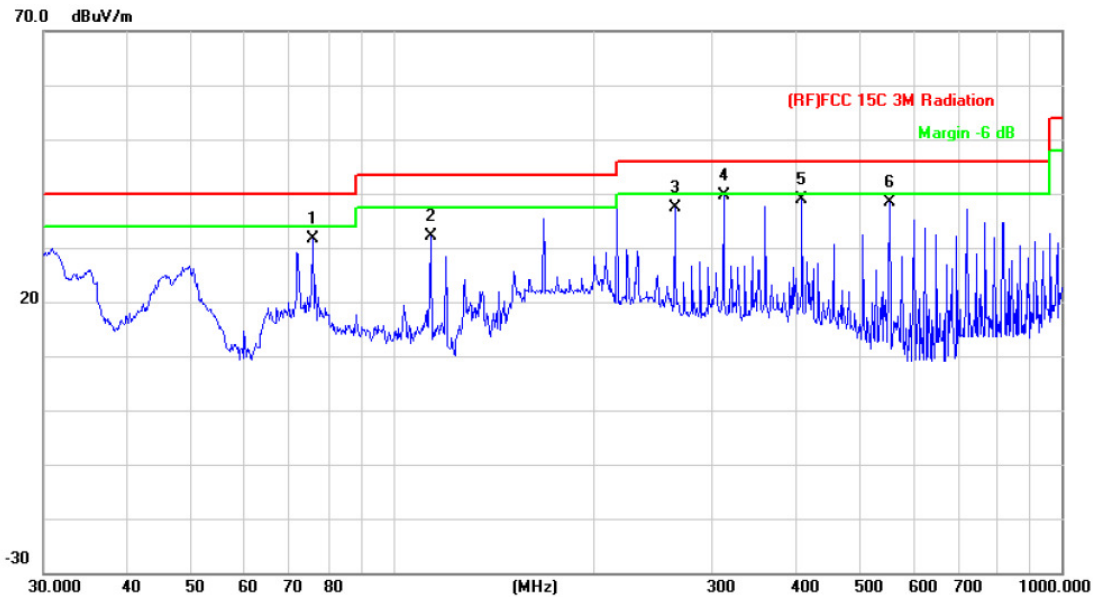

No.	Mk.	Freq. MHz	Reading Level dBuV	Correct Factor dB/m	Measure- ment dBuV/m	Limit dBuV/m	Over dB	Detector
1		75.9770	54.96	-23.42	31.54	40.00	-8.46	peak
2		113.7142	54.34	-22.11	32.23	43.50	-11.27	peak
3		263.8190	55.22	-17.82	37.40	46.00	-8.60	peak
4	*	312.1792	56.32	-16.63	39.69	46.00	-6.31	peak
5		408.9460	51.81	-12.84	38.97	46.00	-7.03	peak
6		552.8831	48.56	-10.13	38.43	46.00	-7.57	peak

\*:Maximum data    x:Over limit    !:over margin

**Emission Level= Read Level+ Correct Factor**

<b>EUT:</b>	Action camera	<b>Model:</b>	9028
<b>Temperature:</b>	25 °C	<b>Relative Humidity:</b>	55%
<b>Test Voltage:</b>	DC 3.7V		
<b>Ant. Pol.</b>	Horizontal		
<b>Test Mode:</b>	TX B Mode 2462MHz		
<b>Remark:</b>	Only worse case is reported		

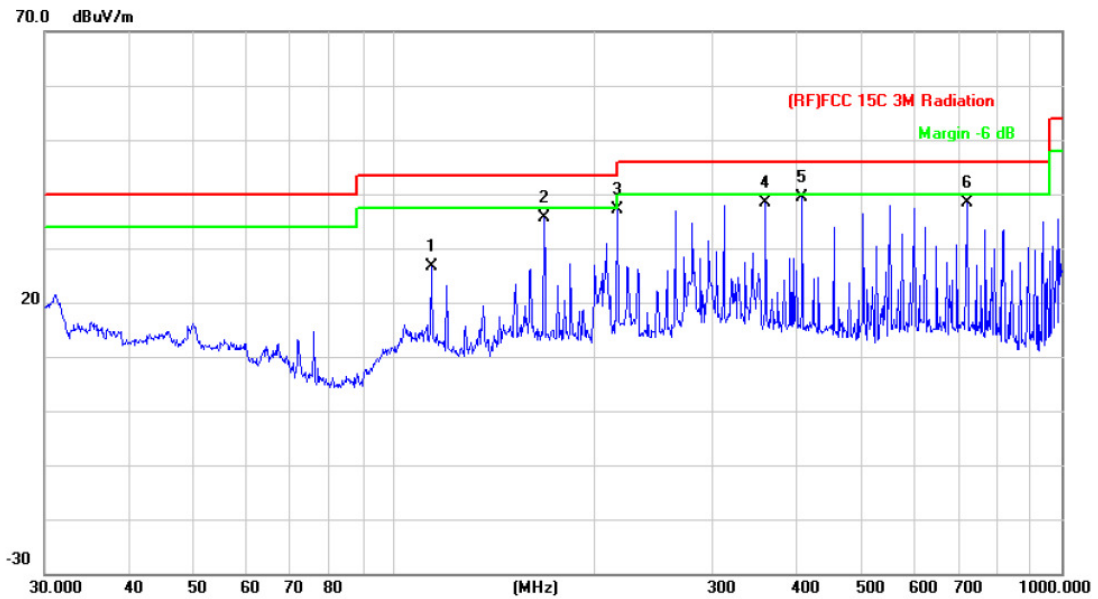

No.	Mk.	Freq. MHz	Reading Level dBuV	Correct Factor dB/m	Measure- ment dBuV/m	Limit dBuV/m	Over dB	Detector
1		113.7142	48.66	-22.11	26.55	43.50	-16.95	peak
2		167.8240	56.66	-21.04	35.62	43.50	-7.88	peak
3		216.0240	56.95	-19.70	37.25	46.00	-8.75	peak
4		360.4476	52.85	-14.55	38.30	46.00	-7.70	peak
5	*	408.9460	52.19	-12.84	39.35	46.00	-6.65	peak
6		721.7259	45.51	-7.10	38.41	46.00	-7.59	peak

\*:Maximum data    x:Over limit    !:over margin

**Emission Level= Read Level+ Correct Factor**

<b>EUT:</b>	Action camera	<b>Model:</b>	9028
<b>Temperature:</b>	25 °C	<b>Relative Humidity:</b>	55%
<b>Test Voltage:</b>	DC 3.7V		
<b>Ant. Pol.</b>	Vertical		
<b>Test Mode:</b>	TX B Mode 2462MHz		
<b>Remark:</b>	Only worse case is reported		

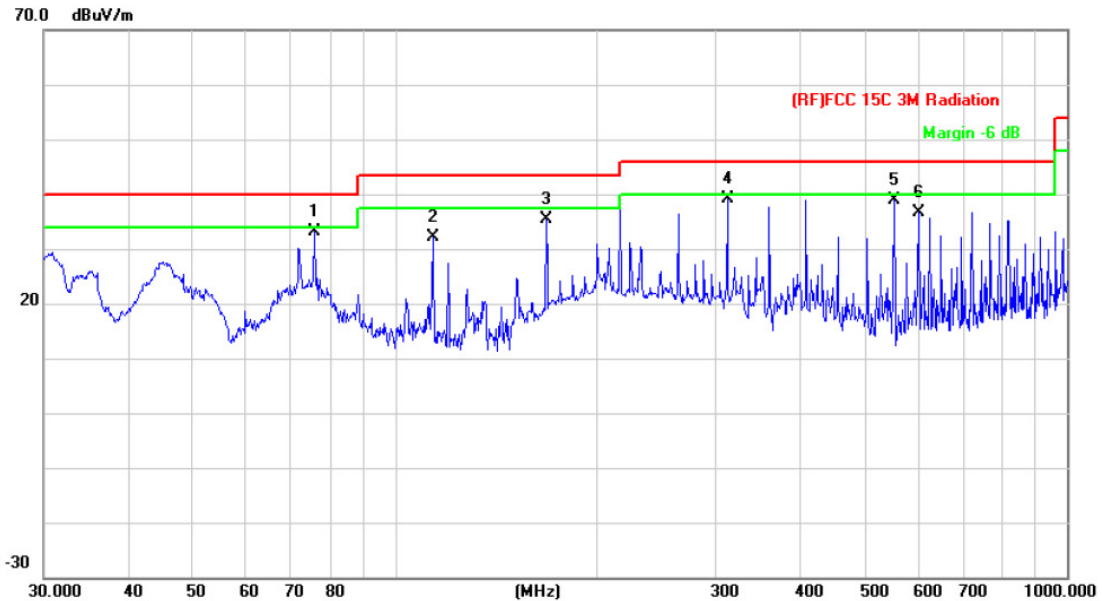

No.	Mk.	Freq.	Reading Level	Correct Factor	Measurement	Limit	Over	
		MHz	dBuV	dB/m	dBuV/m	dBuV/m	dB	Detector
1		75.9770	56.46	-23.42	33.04	40.00	-6.96	peak
2		113.7142	54.34	-22.11	32.23	43.50	-11.27	peak
3		167.8240	56.49	-21.04	35.45	43.50	-8.05	peak
4	*	312.1792	55.82	-16.63	39.19	46.00	-6.81	peak
5		552.8831	49.06	-10.13	38.93	46.00	-7.07	peak
6		601.4265	46.03	-9.41	36.62	46.00	-9.38	peak

\*:Maximum data    x:Over limit    !:over margin

**Emission Level= Read Level+ Correct Factor**

<b>EUT:</b>	Action camera	<b>Model:</b>	9028
<b>Temperature:</b>	25 °C	<b>Relative Humidity:</b>	55%
<b>Test Voltage:</b>	DC 3.7V		
<b>Ant. Pol.</b>	Horizontal		
<b>Test Mode:</b>	TX B Mode 2412MHz		
<b>Remark:</b>	No report for the emission which more than 10 dB below the prescribed limit.		

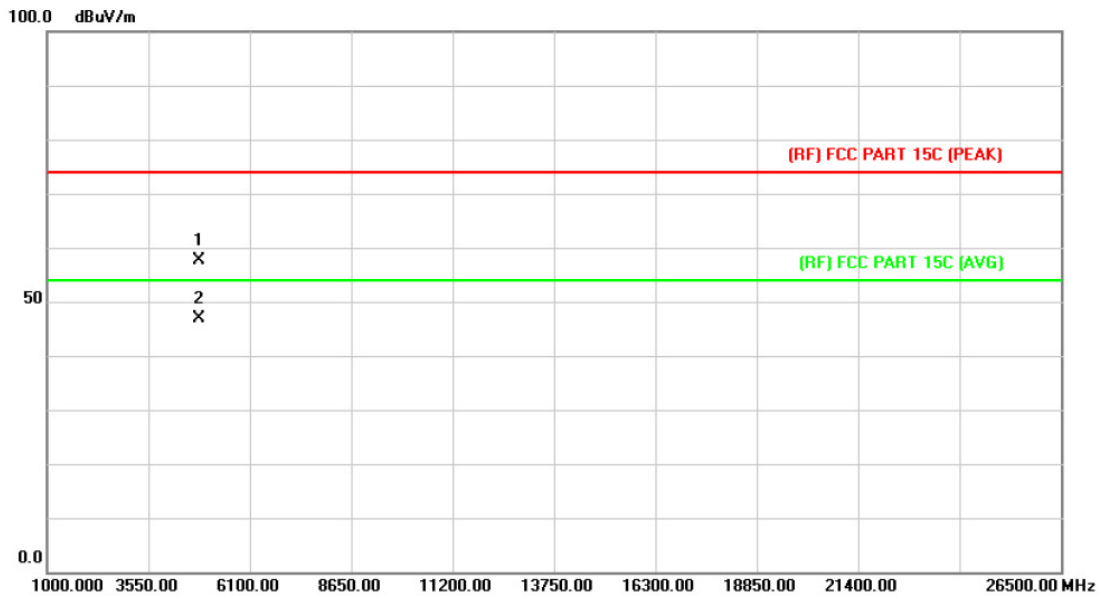

No.	Mk.	Freq.	Reading Level	Correct Factor	Measurement	Limit	Over	Detector
		MHz	dBuV	dB/m	dBuV/m	dBuV/m	dB	
1		4823.997	44.12	13.56	57.68	74.00	-16.32	peak
2	*	4824.120	33.31	13.56	46.87	54.00	-7.13	AVG

Emission Level= Read Level+ Correct Factor

<b>EUT:</b>	Action camera	<b>Model:</b>	9028
<b>Temperature:</b>	25 °C	<b>Relative Humidity:</b>	55%
<b>Test Voltage:</b>	DC 3.7V		
<b>Ant. Pol.</b>	Vertical		
<b>Test Mode:</b>	TX B Mode 2412MHz		
<b>Remark:</b>	No report for the emission which more than 10 dB below the prescribed limit.		

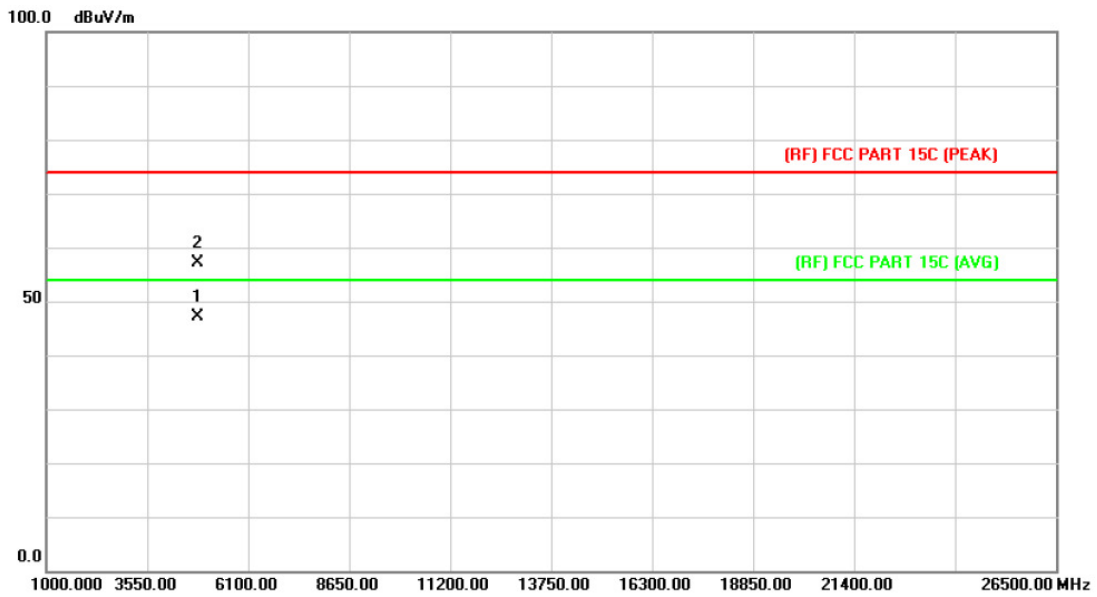

No.	Mk.	Freq.	Reading Level	Correct Factor	Measurement	Limit	Over	Detector
		MHz	dBuV	dB/m	dBuV/m	dBuV/m	dB	
1	*	4823.897	33.50	13.56	47.06	54.00	-6.94	AVG
2		4824.652	43.66	13.56	57.22	74.00	-16.78	peak

Emission Level= Read Level+ Correct Factor

<b>EUT:</b>	Action camera	<b>Model:</b>	9028
<b>Temperature:</b>	25 °C	<b>Relative Humidity:</b>	55%
<b>Test Voltage:</b>	DC 3.7V		
<b>Ant. Pol.</b>	Horizontal		
<b>Test Mode:</b>	TX B Mode 2437MHz		
<b>Remark:</b>	No report for the emission which more than 10 dB below the prescribed limit.		

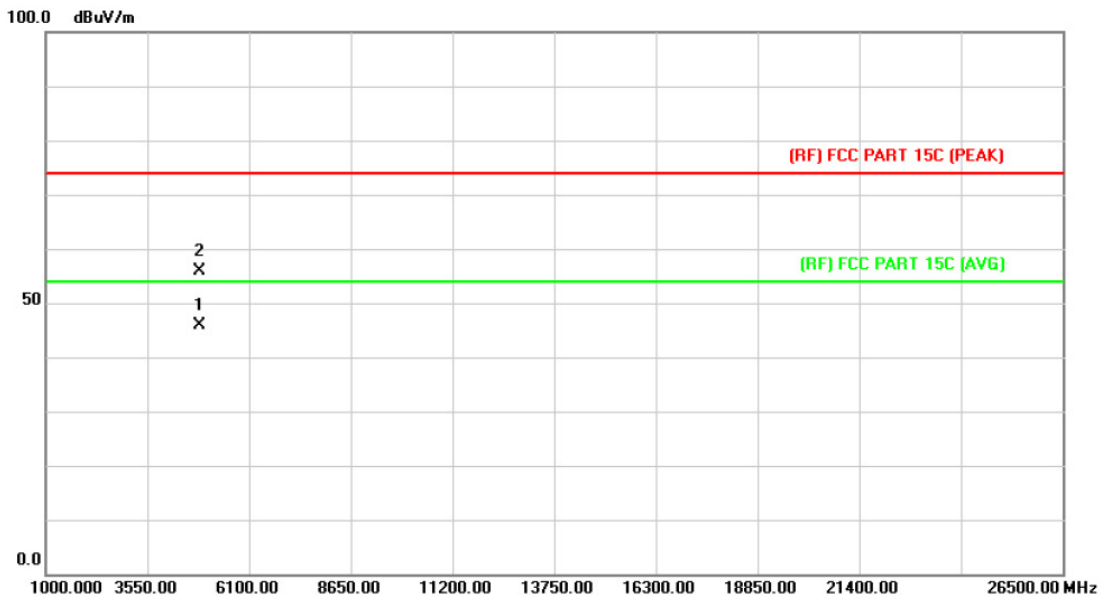

No.	Mk.	Freq.	Reading Level	Correct Factor	Measurement	Limit	Over	Detector
		MHz	dBuV	dB/m	dBuV/m	dBuV/m	dB	
1	*	4873.984	32.12	13.86	45.98	54.00	-8.02	AVG
2		4874.612	42.12	13.86	55.98	74.00	-18.02	peak

Emission Level= Read Level+ Correct Factor

<b>EUT:</b>	Action camera	<b>Model:</b>	9028
<b>Temperature:</b>	25 °C	<b>Relative Humidity:</b>	55%
<b>Test Voltage:</b>	DC 3.7V		
<b>Ant. Pol.</b>	Vertical		
<b>Test Mode:</b>	TX B Mode 2437MHz		
<b>Remark:</b>	No report for the emission which more than 10 dB below the prescribed limit.		

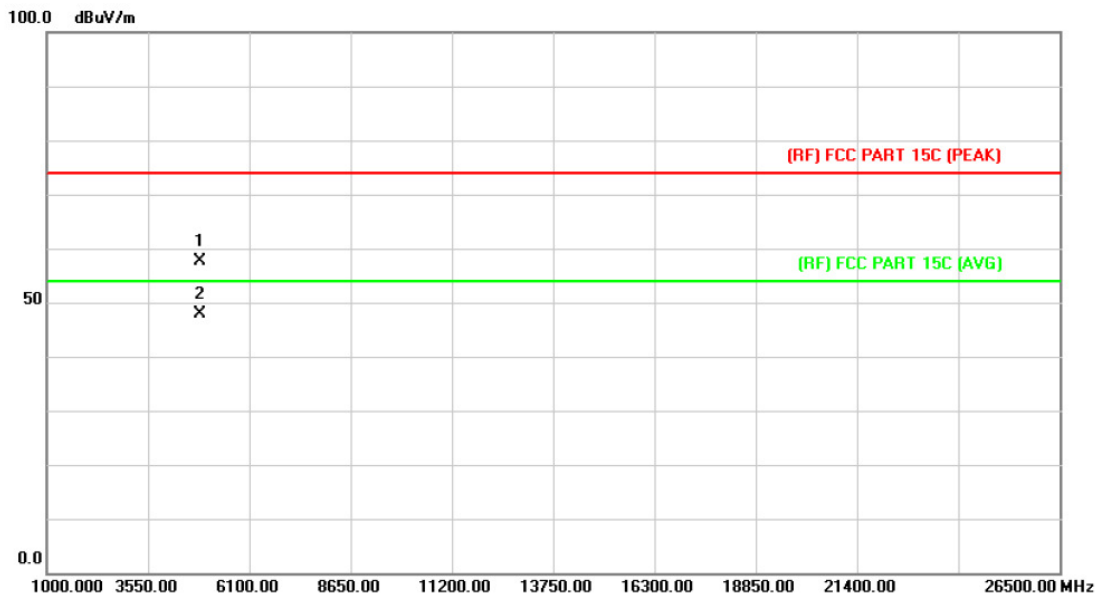

No.	Mk.	Freq.	Reading Level	Correct Factor	Measurement	Limit	Over	
		MHz	dBuV	dB/m	dBuV/m	dBuV/m	dB	Detector
1		4873.584	43.83	13.86	57.69	74.00	-16.31	peak
2	*	4874.672	34.01	13.86	47.87	54.00	-6.13	AVG

Emission Level= Read Level+ Correct Factor

<b>EUT:</b>	Action camera	<b>Model:</b>	9028
<b>Temperature:</b>	25 °C	<b>Relative Humidity:</b>	55%
<b>Test Voltage:</b>	DC 3.7V		
<b>Ant. Pol.</b>	Horizontal		
<b>Test Mode:</b>	TX B Mode 2462MHz		
<b>Remark:</b>	No report for the emission which more than 10 dB below the prescribed limit.		

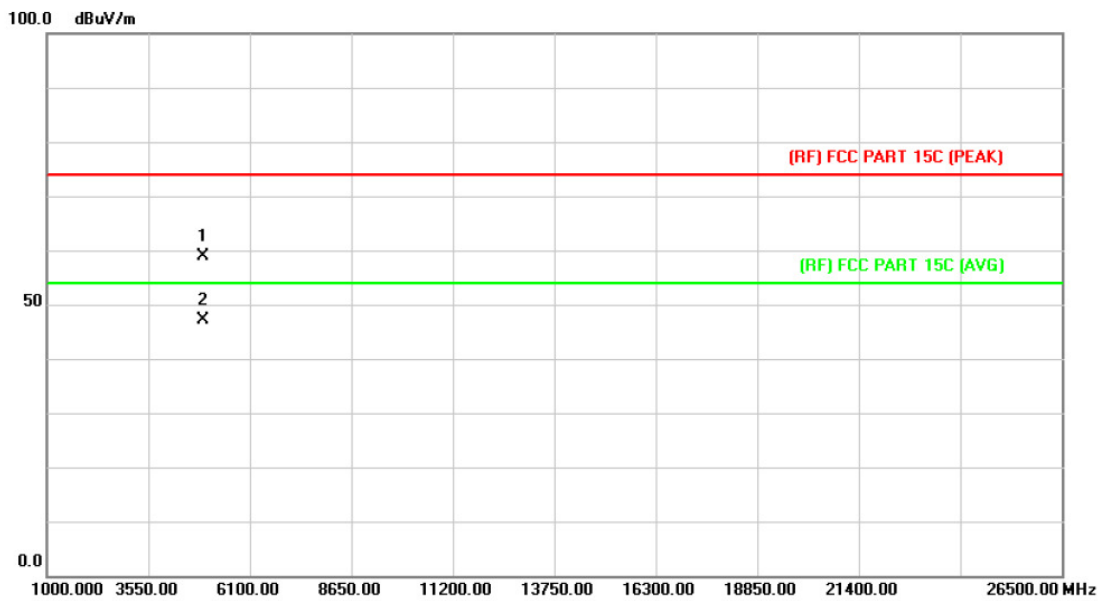

No.	Mk.	Freq.	Reading Level	Correct Factor	Measurement	Limit	Over	Detector
		MHz	dBuV	dB/m	dBuV/m	dBuV/m	dB	
1		4924.674	44.82	14.15	58.97	74.00	-15.03	peak
2	*	4924.674	32.87	14.15	47.02	54.00	-6.98	AVG

Emission Level= Read Level+ Correct Factor

<b>EUT:</b>	Action camera	<b>Model:</b>	9028
<b>Temperature:</b>	25 °C	<b>Relative Humidity:</b>	55%
<b>Test Voltage:</b>	DC 3.7V		
<b>Ant. Pol.</b>	Vertical		
<b>Test Mode:</b>	TX B Mode 2462MHz		
<b>Remark:</b>	No report for the emission which more than 10 dB below the prescribed limit.		

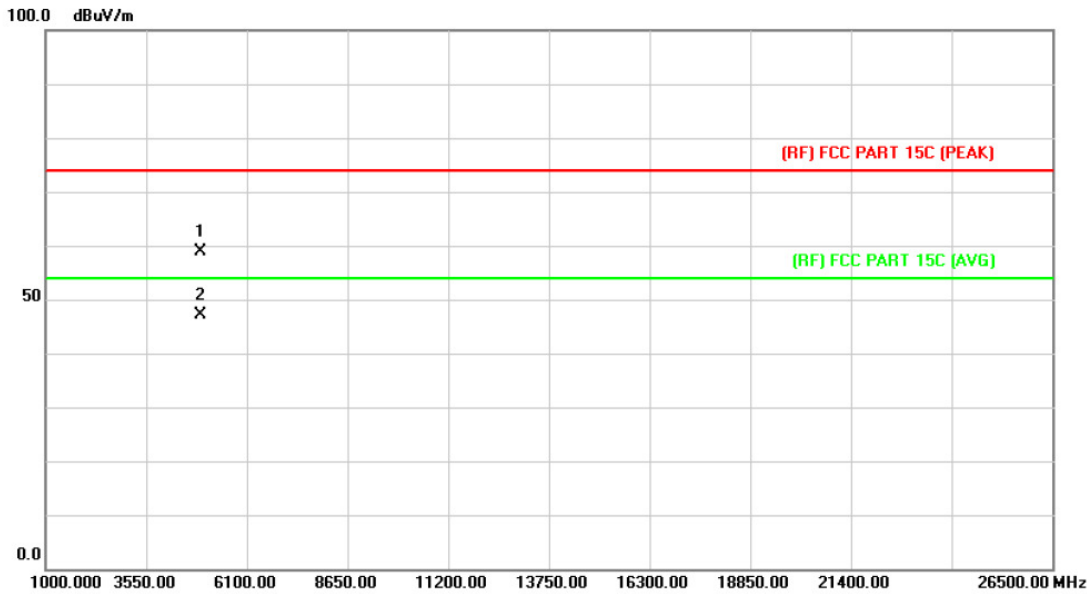

No.	Mk.	Freq.	Reading Level	Correct Factor	Measurement	Limit	Over	Detector
		MHz	dBuV	dB/m	dBuV/m	dBuV/m	dB	
1		4923.687	44.83	14.15	58.98	74.00	-15.02	peak
2	*	4924.367	33.06	14.15	47.21	54.00	-6.79	AVG

Emission Level= Read Level+ Correct Factor

<b>EUT:</b>	Action camera	<b>Model:</b>	9028
<b>Temperature:</b>	25 °C	<b>Relative Humidity:</b>	55%
<b>Test Voltage:</b>	DC 3.7V		
<b>Ant. Pol.</b>	Horizontal		
<b>Test Mode:</b>	TX G Mode 2412MHz		
<b>Remark:</b>	No report for the emission which more than 10 dB below the prescribed limit.		

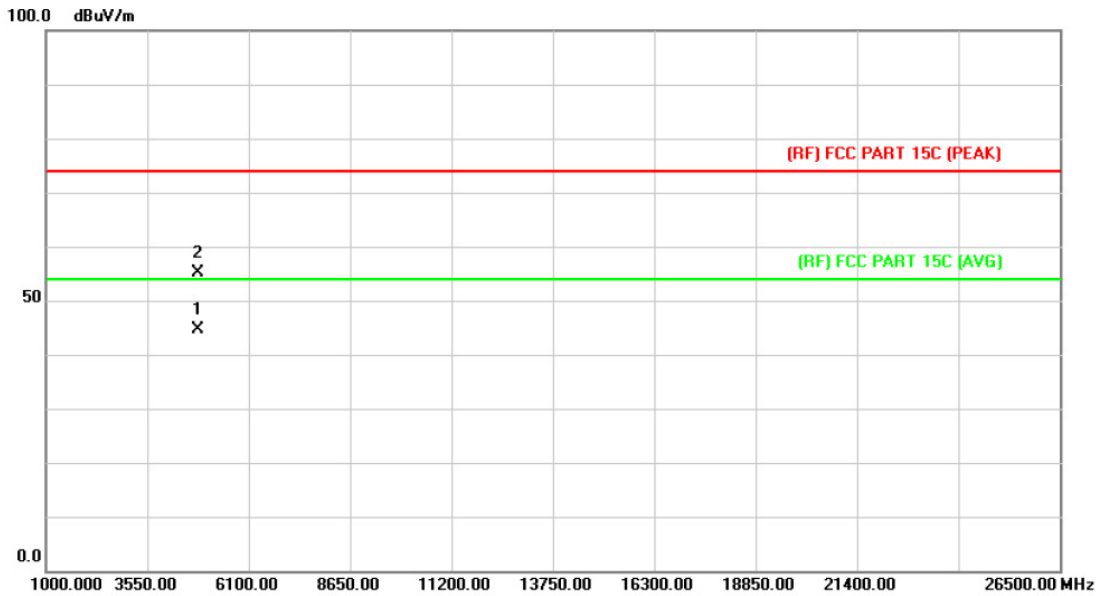

No.	Mk.	Freq. MHz	Reading Level dBuV	Correct Factor dB/m	Measure- ment dBuV/m	Limit dBuV/m	Over dB	Detector
1	*	4823.687	31.11	13.56	44.67	54.00	-9.33	AVG
2		4824.556	41.52	13.56	55.08	74.00	-18.92	peak

Emission Level= Read Level+ Correct Factor

<b>EUT:</b>	Action camera	<b>Model:</b>	9028
<b>Temperature:</b>	25 °C	<b>Relative Humidity:</b>	55%
<b>Test Voltage:</b>	DC 3.7V		
<b>Ant. Pol.</b>	Vertical		
<b>Test Mode:</b>	TX G Mode 2412MHz		
<b>Remark:</b>	No report for the emission which more than 10 dB below the prescribed limit.		

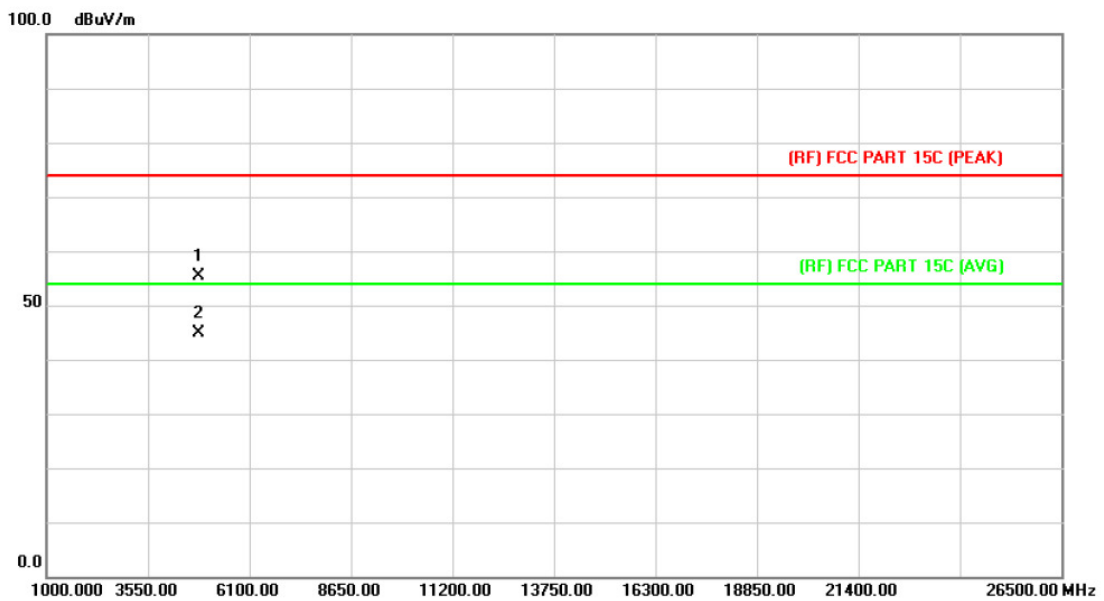

No.	Mk.	Freq. MHz	Reading Level dBuV	Correct Factor dB/m	Measure- ment dBuV/m	Limit dBuV/m	Over dB	Detector
1		4823.654	41.90	13.56	55.46	74.00	-18.54	peak
2	*	4824.622	31.21	13.56	44.77	54.00	-9.23	AVG

Emission Level= Read Level+ Correct Factor

<b>EUT:</b>	Action camera	<b>Model:</b>	9028
<b>Temperature:</b>	25 °C	<b>Relative Humidity:</b>	55%
<b>Test Voltage:</b>	DC 3.7V		
<b>Ant. Pol.</b>	Horizontal		
<b>Test Mode:</b>	TX G Mode 2437MHz		
<b>Remark:</b>	No report for the emission which more than 10 dB below the prescribed limit.		

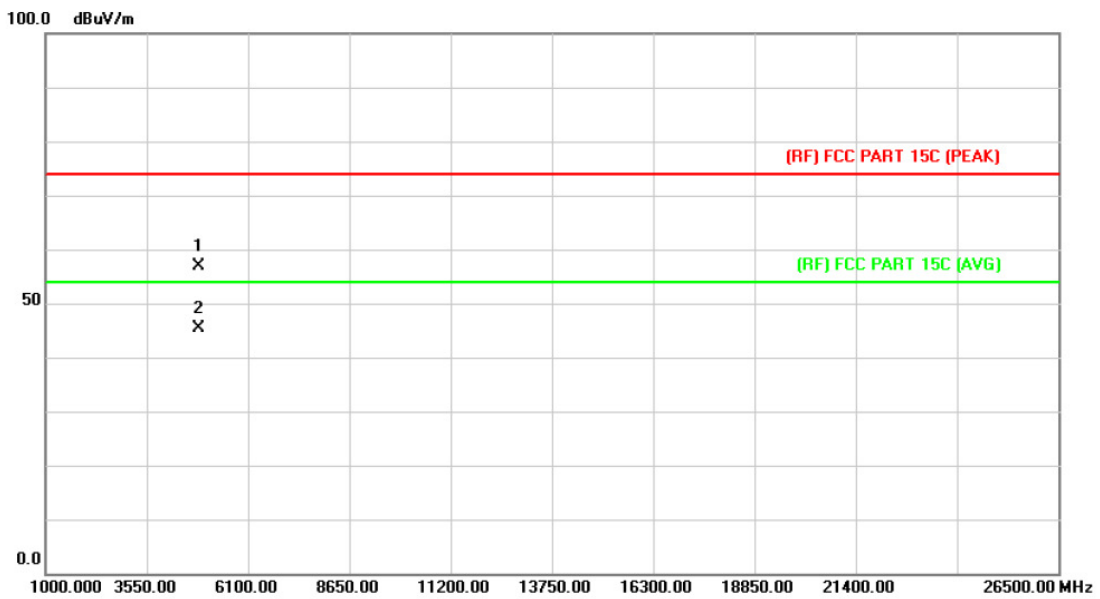

No.	Mk.	Freq. MHz	Reading Level dBuV	Correct Factor dB/m	Measure- ment dBuV/m	Limit dBuV/m	Over dB	Detector
1		4873.654	43.01	13.86	56.87	74.00	-17.13	peak
2	*	4874.032	31.51	13.86	45.37	54.00	-8.63	AVG

Emission Level= Read Level+ Correct Factor

<b>EUT:</b>	Action camera	<b>Model:</b>	9028
<b>Temperature:</b>	25 °C	<b>Relative Humidity:</b>	55%
<b>Test Voltage:</b>	DC 3.7V		
<b>Ant. Pol.</b>	Vertical		
<b>Test Mode:</b>	TX G Mode 2437MHz		
<b>Remark:</b>	No report for the emission which more than 10 dB below the prescribed limit.		

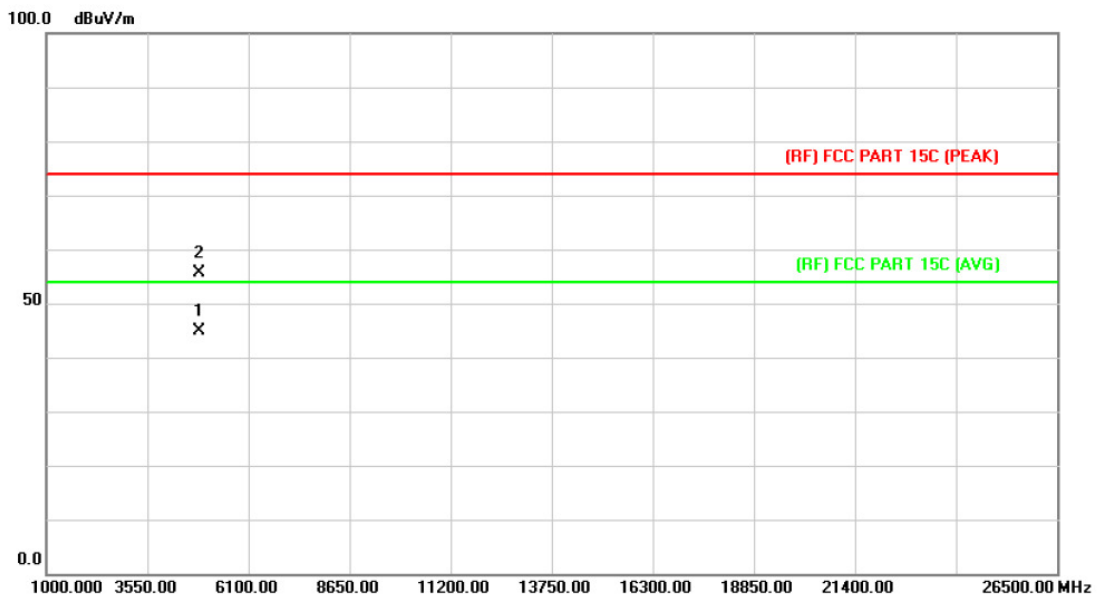

No.	Mk.	Freq.	Reading Level	Correct Factor	Measurement	Limit	Over	Detector
		MHz	dBuV	dB/m	dBuV/m	dBuV/m	dB	
1	*	4873.610	31.11	13.86	44.97	54.00	-9.03	AVG
2		4874.364	41.81	13.86	55.67	74.00	-18.33	peak

Emission Level= Read Level+ Correct Factor

<b>EUT:</b>	Action camera	<b>Model:</b>	9028
<b>Temperature:</b>	25 °C	<b>Relative Humidity:</b>	55%
<b>Test Voltage:</b>	DC 3.7V		
<b>Ant. Pol.</b>	Horizontal		
<b>Test Mode:</b>	TX G Mode 2462MHz		
<b>Remark:</b>	No report for the emission which more than 10 dB below the prescribed limit.		

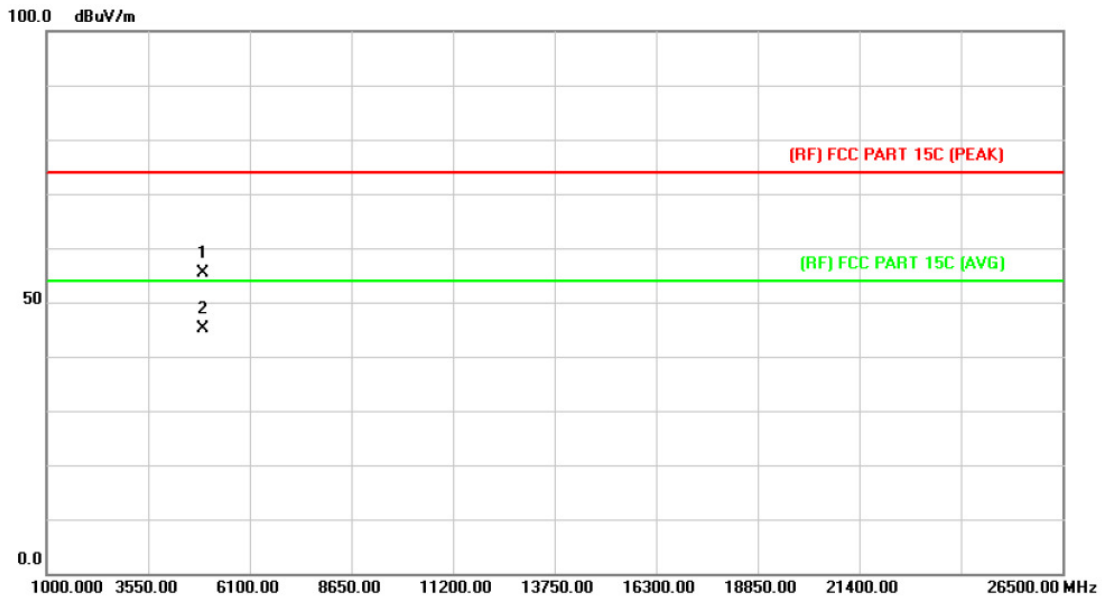

No.	Mk.	Freq.	Reading Level	Correct Factor	Measurement	Limit	Over	Detector
		MHz	dBuV	dB/m	dBuV/m	dBuV/m	dB	
1		4923.608	41.34	14.15	55.49	74.00	-18.51	peak
2	*	4923.987	30.93	14.15	45.08	54.00	-8.92	AVG

Emission Level= Read Level+ Correct Factor

<b>EUT:</b>	Action camera	<b>Model:</b>	9028
<b>Temperature:</b>	25 °C	<b>Relative Humidity:</b>	55%
<b>Test Voltage:</b>	DC 3.7V		
<b>Ant. Pol.</b>	Vertical		
<b>Test Mode:</b>	TX G Mode 2462MHz		
<b>Remark:</b>	No report for the emission which more than 10 dB below the prescribed limit.		

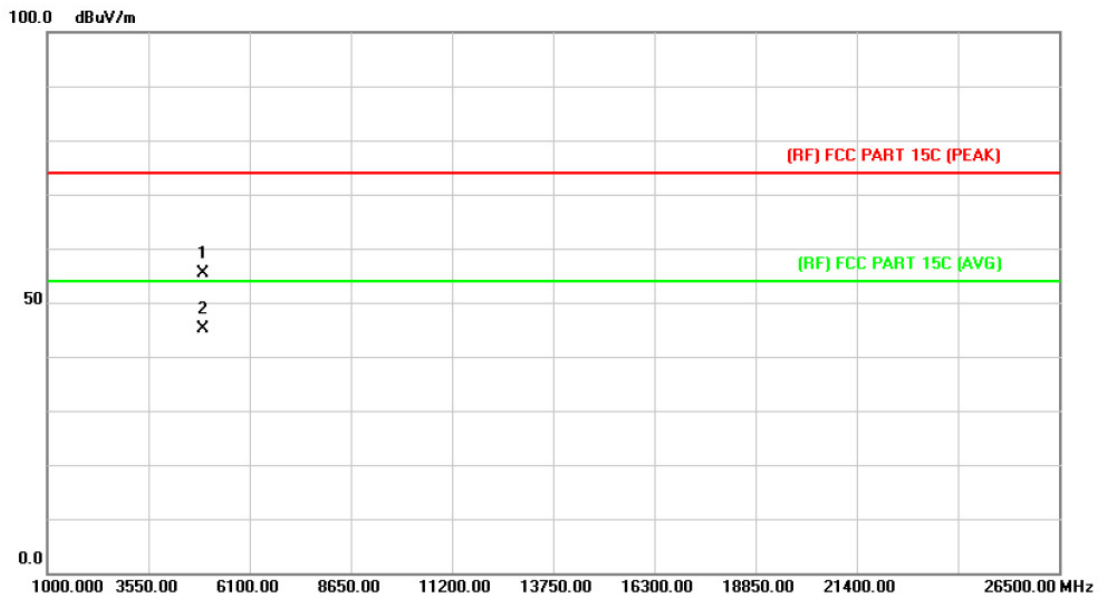

No.	Mk.	Freq.	Reading Level	Correct Factor	Measurement	Limit	Over	Detector
		MHz	dBuV	dB/m	dBuV/m	dBuV/m	dB	
1		4923.574	41.19	14.15	55.34	74.00	-18.66	peak
2	*	4923.621	30.89	14.15	45.04	54.00	-8.96	AVG

Emission Level= Read Level+ Correct Factor

<b>EUT:</b>	Action camera	<b>Model:</b>	9028
<b>Temperature:</b>	25 °C	<b>Relative Humidity:</b>	55%
<b>Test Voltage:</b>	DC 3.7V		
<b>Ant. Pol.</b>	Horizontal		
<b>Test Mode:</b>	TX N(HT20) Mode 2412MHz		
<b>Remark:</b>	No report for the emission which more than 10 dB below the prescribed limit.		

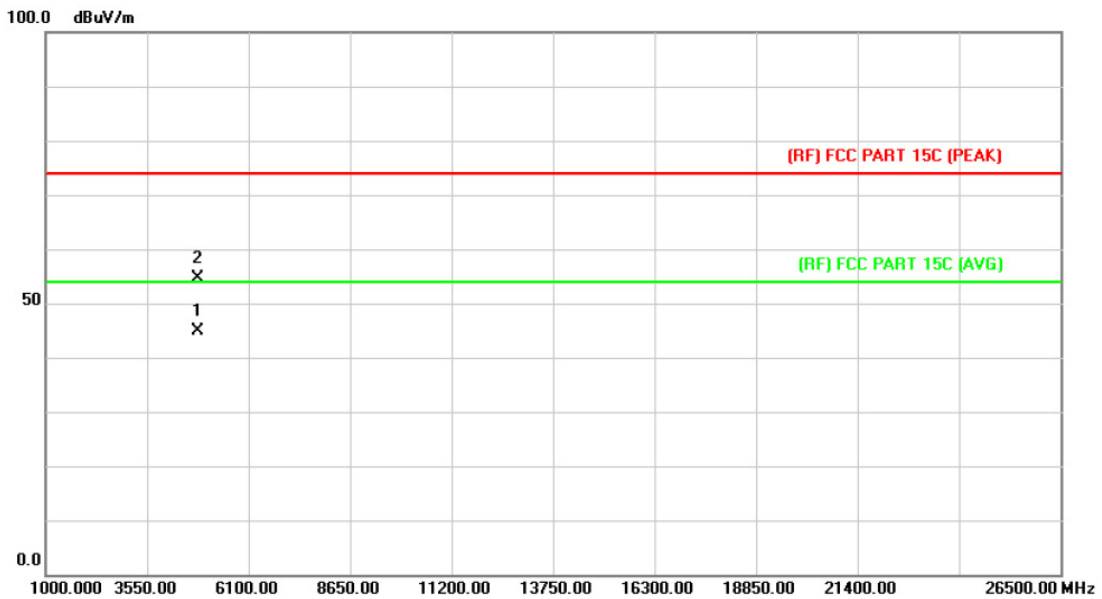

No.	Mk.	Freq.	Reading Level	Correct Factor	Measurement	Limit	Over	Detector
		MHz	dBuV	dB/m	dBuV/m	dBuV/m	dB	
1	*	4824.341	31.42	13.56	44.98	54.00	-9.02	AVG
2		4824.351	41.11	13.56	54.67	74.00	-19.33	peak

Emission Level= Read Level+ Correct Factor

<b>EUT:</b>	Action camera	<b>Model:</b>	9028
<b>Temperature:</b>	25 °C	<b>Relative Humidity:</b>	55%
<b>Test Voltage:</b>	DC 3.7V		
<b>Ant. Pol.</b>	Vertical		
<b>Test Mode:</b>	TX N(HT20) Mode 2412MHz		
<b>Remark:</b>	No report for the emission which more than 10 dB below the prescribed limit.		

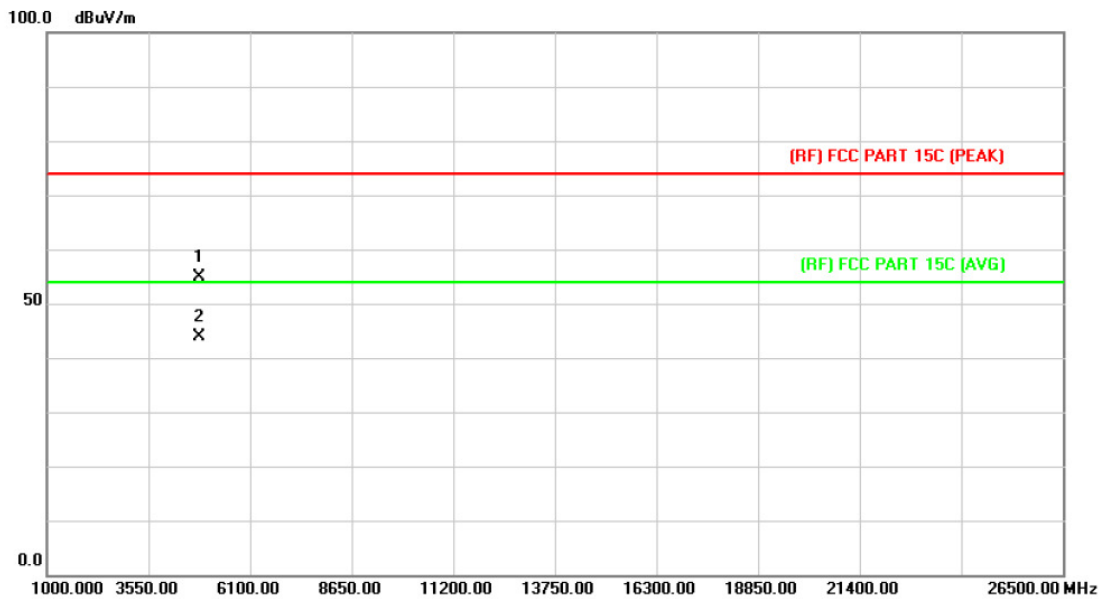

No.	Mk.	Freq.	Reading Level	Correct Factor	Measurement	Limit	Over	Detector
		MHz	dBuV	dB/m	dBuV/m	dBuV/m	dB	
1		4823.684	41.43	13.56	54.99	74.00	-19.01	peak
2	*	4824.671	30.41	13.56	43.97	54.00	-10.03	AVG

Emission Level= Read Level+ Correct Factor

<b>EUT:</b>	Action camera	<b>Model:</b>	9028
<b>Temperature:</b>	25 °C	<b>Relative Humidity:</b>	55%
<b>Test Voltage:</b>	DC 3.7V		
<b>Ant. Pol.</b>	Horizontal		
<b>Test Mode:</b>	TX N(HT20) Mode 2437MHz		
<b>Remark:</b>	No report for the emission which more than 10 dB below the prescribed limit.		

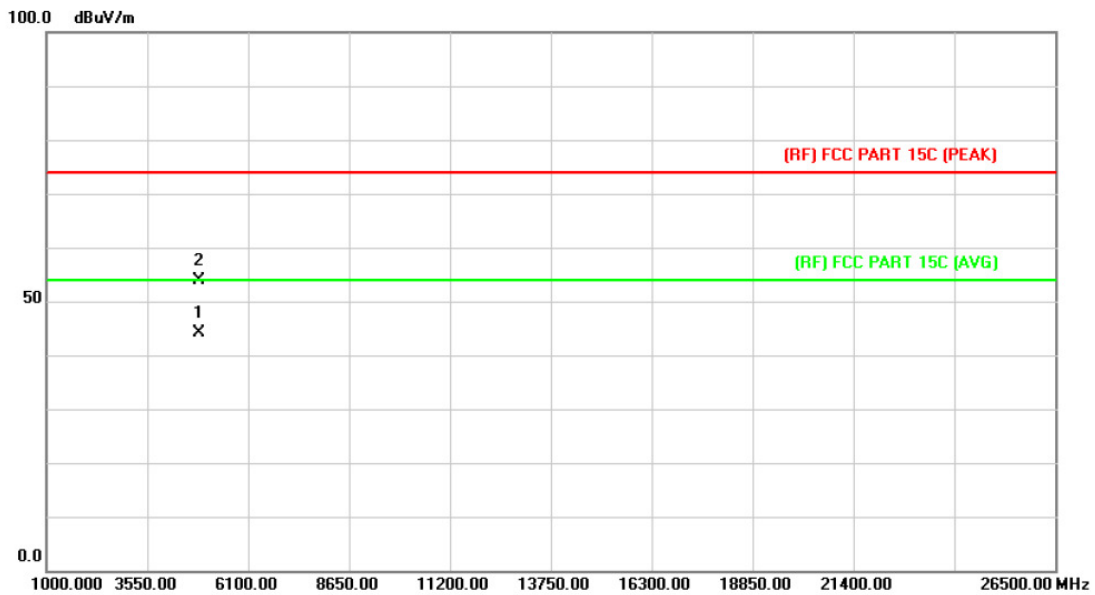

No.	Mk.	Freq.	Reading Level	Correct Factor	Measurement	Limit	Over	Detector
		MHz	dBuV	dB/m	dBuV/m	dBuV/m	dB	
1	*	4873.608	30.35	13.86	44.21	54.00	-9.79	AVG
2		4874.084	40.13	13.86	53.99	74.00	-20.01	peak

Emission Level= Read Level+ Correct Factor

<b>EUT:</b>	Action camera	<b>Model:</b>	9028
<b>Temperature:</b>	25 °C	<b>Relative Humidity:</b>	55%
<b>Test Voltage:</b>	DC 3.7V		
<b>Ant. Pol.</b>	Vertical		
<b>Test Mode:</b>	TX N(HT20) Mode 2437MHz		
<b>Remark:</b>	No report for the emission which more than 10 dB below the prescribed limit.		

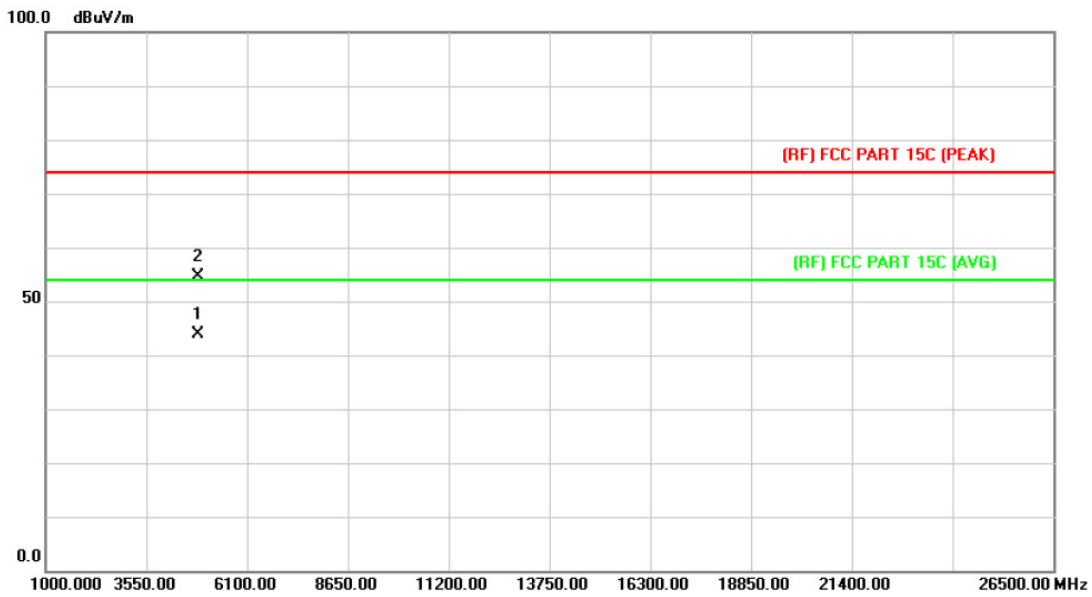

No.	Mk.	Freq. MHz	Reading Level dBuV	Correct Factor dB/m	Measure- ment dBuV/m	Limit dBuV/m	Over dB	Detector
1	*	4873.985	30.01	13.86	43.87	54.00	-10.13	AVG
2		4874.025	40.76	13.86	54.62	74.00	-19.38	peak

Emission Level= Read Level+ Correct Factor

<b>EUT:</b>	Action camera	<b>Model:</b>	9028
<b>Temperature:</b>	25 °C	<b>Relative Humidity:</b>	55%
<b>Test Voltage:</b>	DC 3.7V		
<b>Ant. Pol.</b>	Horizontal		
<b>Test Mode:</b>	TX N(HT20) Mode 2462MHz		
<b>Remark:</b>	No report for the emission which more than 10 dB below the prescribed limit.		

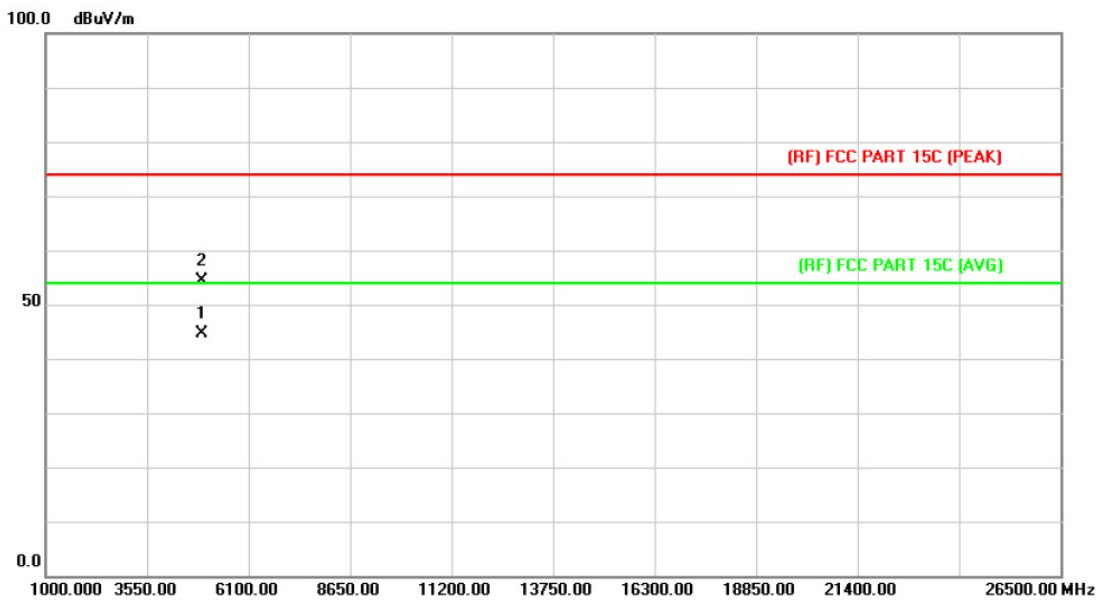

No.	Mk.	Freq.	Reading Level	Correct Factor	Measurement	Limit	Over	Detector
		MHz	dBuV	dB/m	dBuV/m	dBuV/m	dB	
1	*	4923.854	30.44	14.15	44.59	54.00	-9.41	AVG
2		4924.314	40.22	14.15	54.37	74.00	-19.63	peak

Emission Level= Read Level+ Correct Factor

<b>EUT:</b>	Action camera	<b>Model:</b>	9028
<b>Temperature:</b>	25 °C	<b>Relative Humidity:</b>	55%
<b>Test Voltage:</b>	DC 3.7V		
<b>Ant. Pol.</b>	Vertical		
<b>Test Mode:</b>	TX N(HT20) Mode 2462MHz		
<b>Remark:</b>	No report for the emission which more than 10 dB below the prescribed limit.		

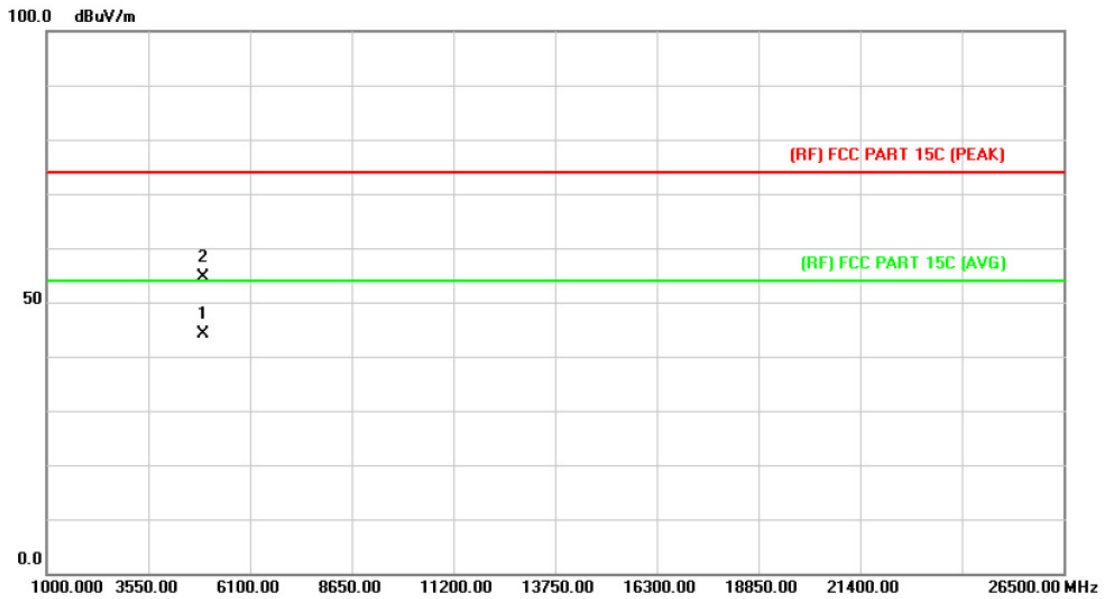

No.	Mk.	Freq. MHz	Reading Level dBuV	Correct Factor dB/m	Measure- ment dBuV/m	Limit dBuV/m	Over dB	Detector
1	*	4923.874	29.91	14.15	44.06	54.00	-9.94	AVG
2		4924.084	40.53	14.15	54.68	74.00	-19.32	peak

Emission Level= Read Level+ Correct Factor

<b>EUT:</b>	Action camera	<b>Model:</b>	9028
<b>Temperature:</b>	25 °C	<b>Relative Humidity:</b>	55%
<b>Test Voltage:</b>	DC 3.7V		
<b>Ant. Pol.</b>	Horizontal		
<b>Test Mode:</b>	TX N(HT40) Mode 2422MHz		
<b>Remark:</b>	No report for the emission which more than 10 dB below the prescribed limit.		

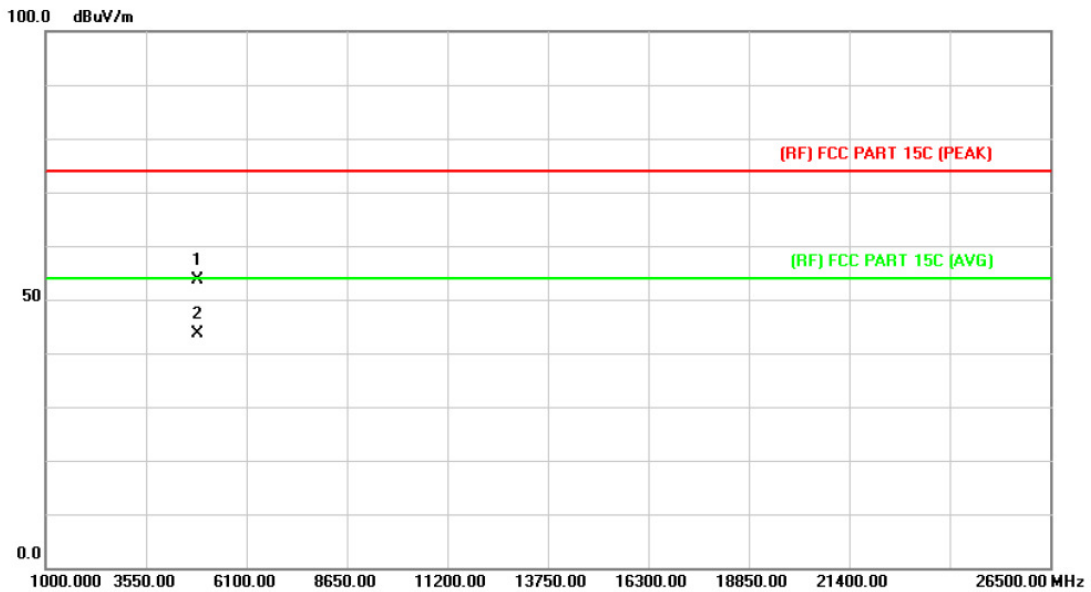

No.	Mk.	Freq.	Reading Level	Correct Factor	Measurement	Limit	Over	
		MHz	dBuV	dB/m	dBuV/m	dBuV/m	dB	Detector
1		4844.054	40.00	13.68	53.68	74.00	-20.32	peak
2	*	4844.321	29.90	13.68	43.58	54.00	-10.42	AVG

Emission Level= Read Level+ Correct Factor

<b>EUT:</b>	Action camera	<b>Model:</b>	9028
<b>Temperature:</b>	25 °C	<b>Relative Humidity:</b>	55%
<b>Test Voltage:</b>	DC 3.7V		
<b>Ant. Pol.</b>	Vertical		
<b>Test Mode:</b>	TX N(HT40) Mode 2422MHz		
<b>Remark:</b>	No report for the emission which more than 10 dB below the prescribed limit.		

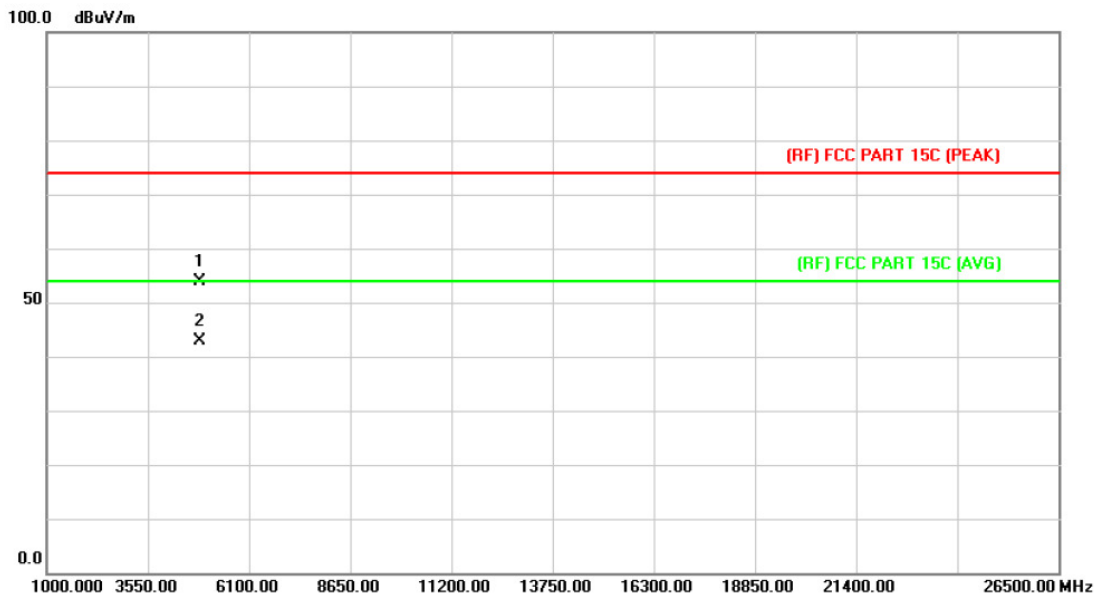

No.	Mk.	Freq.	Reading Level	Correct Factor	Measurement	Limit	Over	Detector
		MHz	dBuV	dB/m	dBuV/m	dBuV/m	dB	
1		4843.956	40.19	13.68	53.87	74.00	-20.13	peak
2	*	4844.041	29.30	13.68	42.98	54.00	-11.02	AVG

Emission Level= Read Level+ Correct Factor

Emission Level= Read Level+ Correct Factor

<b>EUT:</b>	Action camera	<b>Model:</b>	9028
<b>Temperature:</b>	25 °C	<b>Relative Humidity:</b>	55%
<b>Test Voltage:</b>	DC 3.7V		
<b>Ant. Pol.</b>	Horizontal		
<b>Test Mode:</b>	TX N(HT40) Mode 2437MHz		
<b>Remark:</b>	No report for the emission which more than 10 dB below the prescribed limit.		

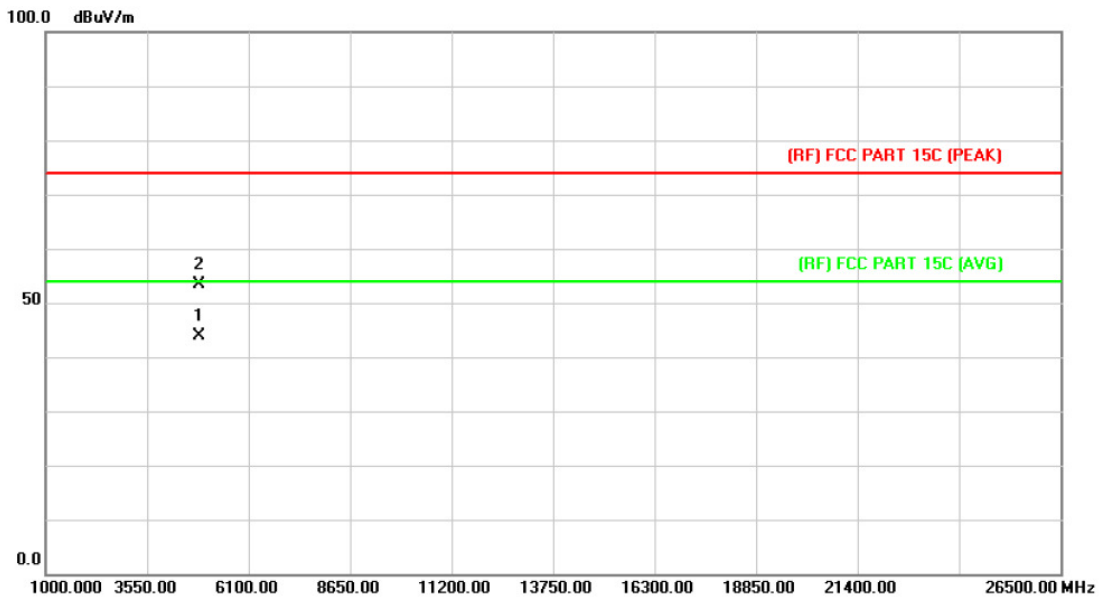

No.	Mk.	Freq.	Reading Level	Correct Factor	Measurement	Limit	Over	Detector
		MHz	dBuV	dB/m	dBuV/m	dBuV/m	dB	
1	*	4873.645	30.02	13.86	43.88	54.00	-10.12	AVG
2		4873.691	39.59	13.86	53.45	74.00	-20.55	peak

Emission Level= Read Level+ Correct Factor

<b>EUT:</b>	Action camera	<b>Model:</b>	9028
<b>Temperature:</b>	25 °C	<b>Relative Humidity:</b>	55%
<b>Test Voltage:</b>	DC 3.7V		
<b>Ant. Pol.</b>	Vertical		
<b>Test Mode:</b>	TX N(HT40) Mode 2437MHz		
<b>Remark:</b>	No report for the emission which more than 10 dB below the prescribed limit.		

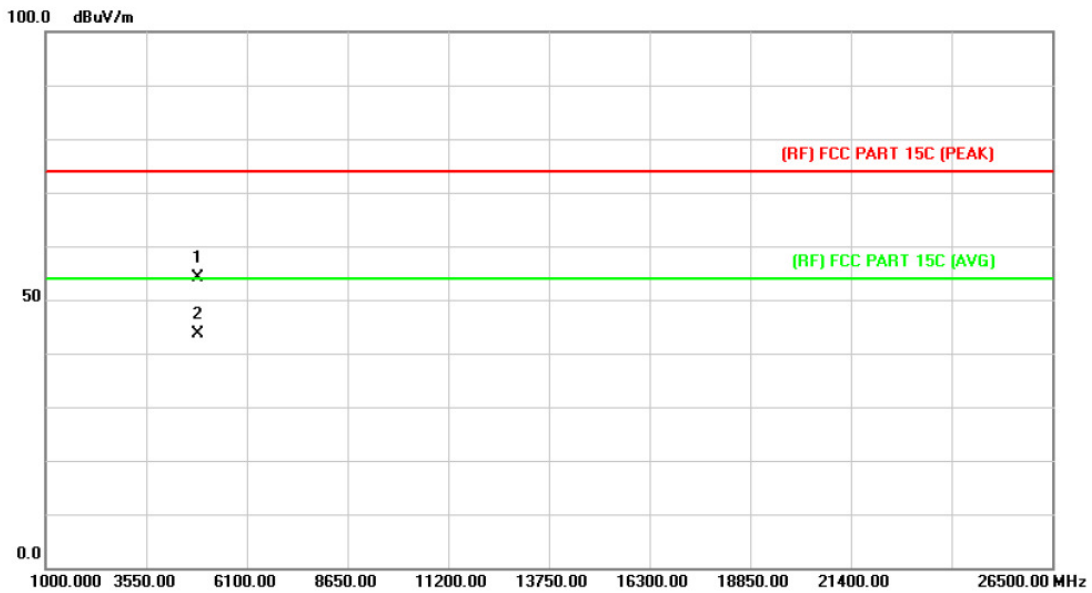

No.	Mk.	Freq.	Reading Level	Correct Factor	Measurement	Limit	Over	Detector
		MHz	dBuV	dB/m	dBuV/m	dBuV/m	dB	
1		4873.984	40.16	13.86	54.02	74.00	-19.98	peak
2	*	4874.521	29.71	13.86	43.57	54.00	-10.43	AVG

Emission Level= Read Level+ Correct Factor

<b>EUT:</b>	Action camera	<b>Model:</b>	9028
<b>Temperature:</b>	25 °C	<b>Relative Humidity:</b>	55%
<b>Test Voltage:</b>	DC 3.7V		
<b>Ant. Pol.</b>	Horizontal		
<b>Test Mode:</b>	TX N(HT40) Mode 2452MHz		
<b>Remark:</b>	No report for the emission which more than 10 dB below the prescribed limit.		

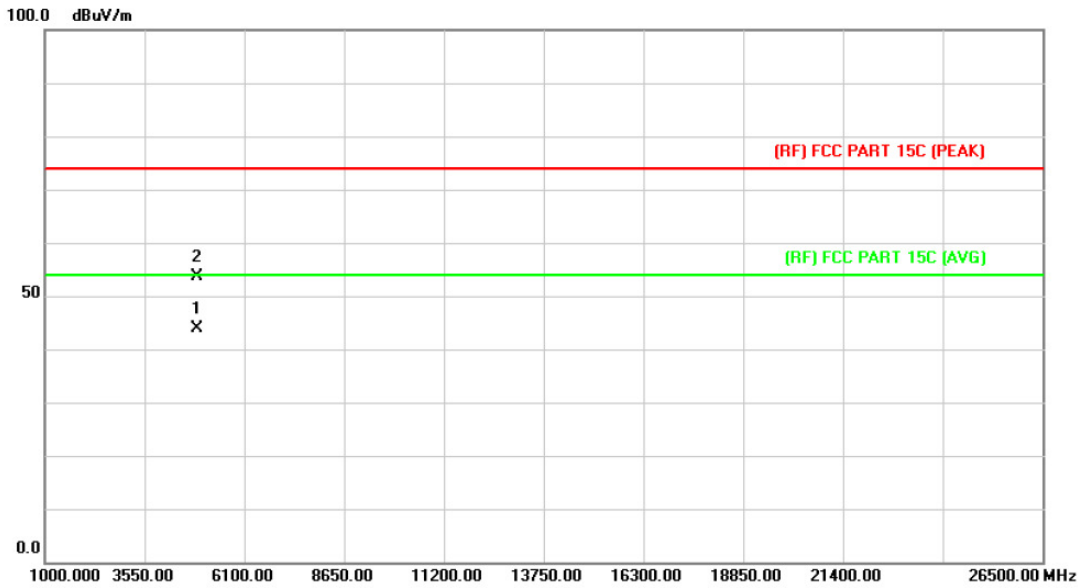

No.	Mk.	Freq.	Reading Level	Correct Factor	Measurement	Limit	Over	Detector
		MHz	dBuV	dB/m	dBuV/m	dBuV/m	dB	
1	*	4903.574	29.84	14.03	43.87	54.00	-10.13	AVG
2		4904.751	39.56	14.03	53.59	74.00	-20.41	peak

Emission Level= Read Level+ Correct Factor

<b>EUT:</b>	Action camera	<b>Model:</b>	9028
<b>Temperature:</b>	25 °C	<b>Relative Humidity:</b>	55%
<b>Test Voltage:</b>	DC 3.7V		
<b>Ant. Pol.</b>	Vertical		
<b>Test Mode:</b>	TX N(HT40) Mode 2452MHz		
<b>Remark:</b>	No report for the emission which more than 10 dB below the prescribed limit.		

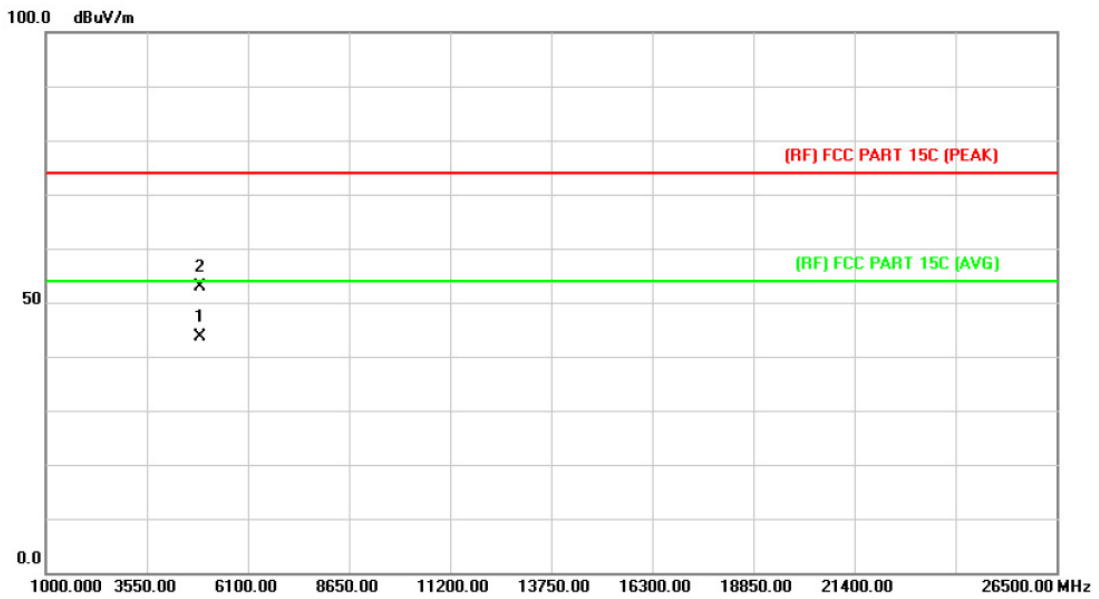

No.	Mk.	Freq.	Reading Level	Correct Factor	Measurement	Limit	Over	Detector
		MHz	dBuV	dB/m	dBuV/m	dBuV/m	dB	
1	*	4903.841	29.65	14.03	43.68	54.00	-10.32	AVG
2		4904.795	38.93	14.03	52.96	74.00	-21.04	peak

Emission Level= Read Level+ Correct Factor

## 6. Restricted Bands Requirement

### 6.1 Test Standard and Limit

#### 6.1.1 Test Standard

FCC Part 15.209 FCC Part 15.205

#### 6.1.2 Test Limit

Restricted Frequency Band (MHz)	Class B (dBuV/m)(at 3 M)	
	Peak	Average
2310 ~2390	74	54
2483.5 ~2500	74	54

### 6.2 Test Setup

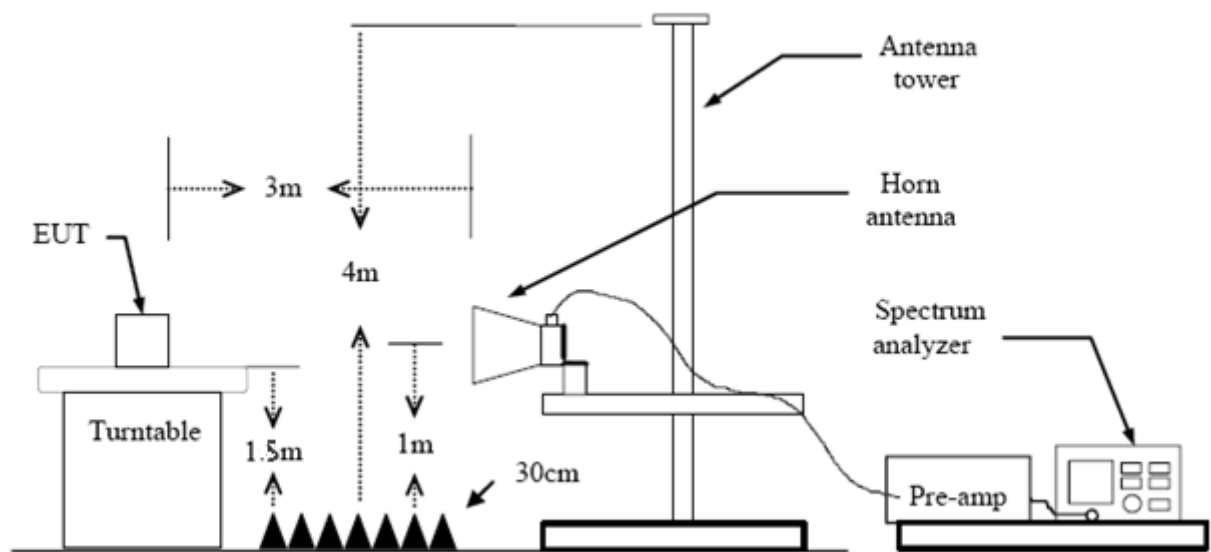

### 6.3 Test Procedure

- (1) The measuring distance of 3m shall be used for measurements at frequency up to 1GHz and above 1 GHz. The EUT was placed on a rotating 0.8m high above ground, the table was rotated 360 degrees to determine the position of the highest radiation.
- (2) Measurements at frequency above 1GHz. The EUT was placed on a rotating 1.5m high above the ground. RF absorbers covered the ground plane with a minimum area of 3.0m by 3.0m between the EUT and measurement receiver antenna. The RF absorber shall not exceed 30cm in high above the conducting floor. The table was rotated 360 degrees to determine the position of the highest radiation.
- (3) The Test antenna shall vary between 1m and 4m, Both Horizontal and Vertical antenna are set to make measurement.

- (4) The initial step in collecting conducted emission data is a spectrum analyzer peak detector mode pre-scanning the measurement frequency range. Significant peaks are then marked and then Quasi Peak detector mode re-measured.
- (5) If the Peak Mode measured value compliance with and lower than Quasi Peak Mode Limit Bellow 1 GHz, the EUT shall be deemed to meet QP Limits and then no additional QP Mode measurement performed. But the Peak Value and average value both need to comply with applicable limit above 1 GHz.
- (6) Testing frequency range below 1GHz the measuring instrument use VBW=120 kHz with Quasi-peak detection.
- (7) Testing frequency range above 1GHz the measuring instrument use RBW=1 MHz and VBW=3 MHz with Peak Detector for Peak Values, and use RBW=1 MHz and VBW=10 Hz with Peak Detector for Average Values.
- (8) For the actual test configuration, please see the test setup photo.

#### 6.4 EUT Operating Condition

The Equipment Under Test was set to Continual Transmitting in maximum power.

#### 6.5 Test Data

Please see the next page.

**(1) Radiation Test**

<b>EUT:</b>	Action camera	<b>Model:</b>	9028
<b>Temperature:</b>	25 °C	<b>Relative Humidity:</b>	55%
<b>Test Voltage:</b>	DC 3.7V		
<b>Ant. Pol.</b>	Horizontal		
<b>Test Mode:</b>	TX B Mode 2412MHz		
<b>Remark:</b>	N/A		

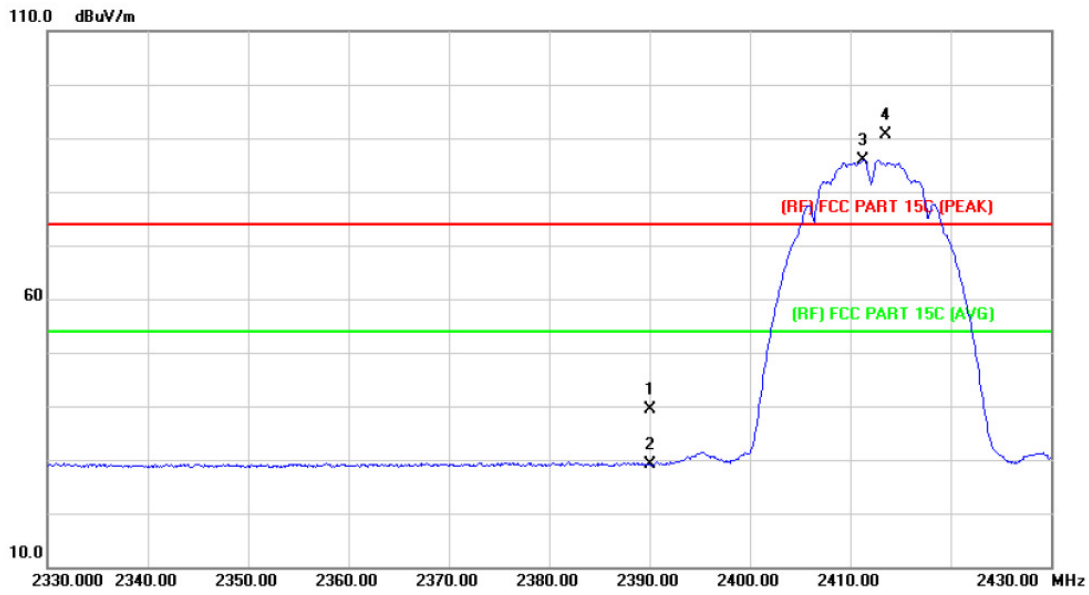

No.	Mk.	Freq. MHz	Reading Level dBuV	Correct Factor dB/m	Measure- ment dBuV/m	Limit dBuV/m	Over dB	Detector
1		2390.000	38.69	0.77	39.46	74.00	-34.54	peak
2		2390.000	28.38	0.77	29.15	54.00	-24.85	AVG
3	*	2411.300	85.05	0.86	85.91	Fundamental Frequency		AVG
4	X	2413.500	89.77	0.86	90.63	Fundamental Frequency		peak

Emission Level= Read Level+ Correct Factor

<b>EUT:</b>	Action camera	<b>Model:</b>	9028
<b>Temperature:</b>	25 °C	<b>Relative Humidity:</b>	55%
<b>Test Voltage:</b>	DC 3.7V		
<b>Ant. Pol.</b>	Vertical		
<b>Test Mode:</b>	TX B Mode 2412MHz		
<b>Remark:</b>	N/A		

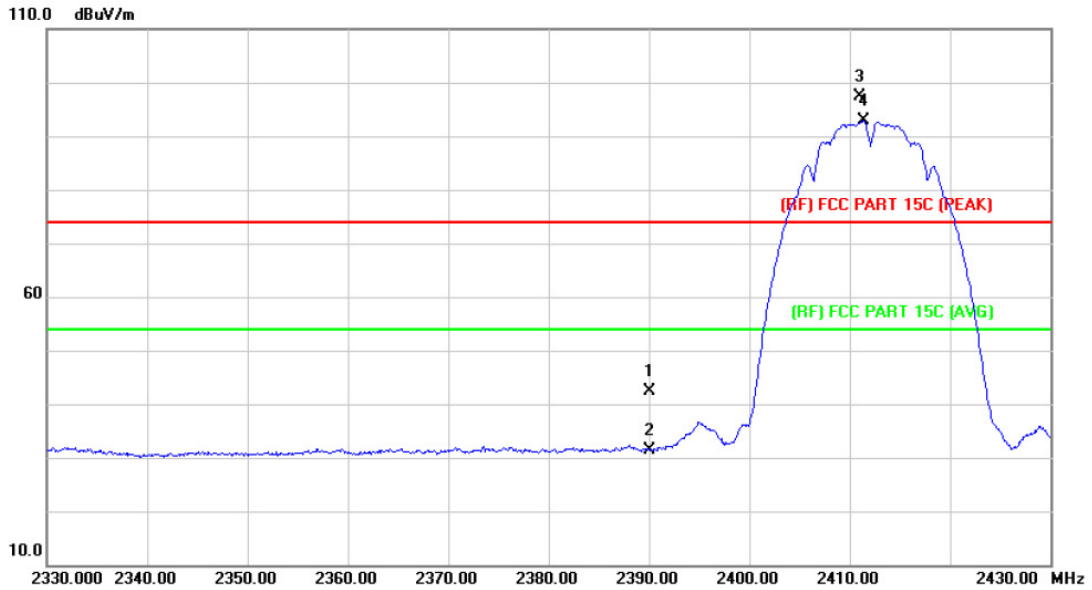

No.	Mk.	Freq.	Reading Level	Correct Factor	Measurement	Limit	Over	Detector
		MHz	dBuV	dB/m	dBuV/m	dBuV/m	dB	
1		2390.000	41.49	0.77	42.26	74.00	-31.74	peak
2		2390.000	30.57	0.77	31.34	54.00	-22.66	AVG
3	X	2411.000	96.59	0.86	97.45	Fundamental Frequency		peak
4	*	2411.400	91.93	0.86	92.79	Fundamental Frequency		AVG

Emission Level= Read Level+ Correct Factor

<b>EUT:</b>	Action camera	<b>Model:</b>	9028
<b>Temperature:</b>	25 °C	<b>Relative Humidity:</b>	55%
<b>Test Voltage:</b>	DC 3.7V		
<b>Ant. Pol.</b>	Horizontal		
<b>Test Mode:</b>	TX B Mode 2462MHz		
<b>Remark:</b>	N/A		

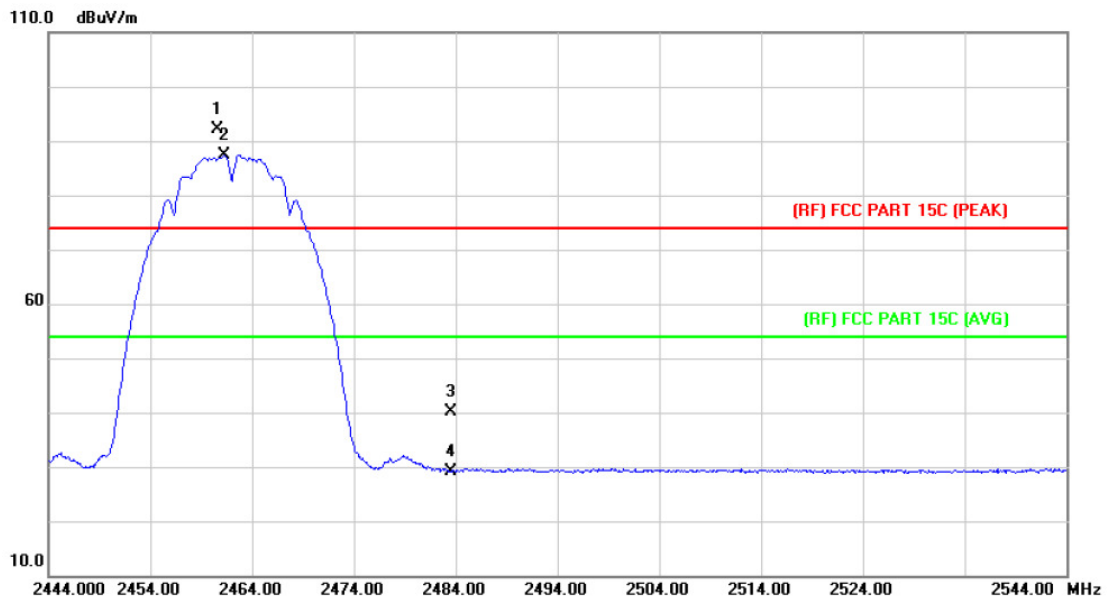

No.	Mk.	Freq. MHz	Reading Level dBuV	Correct Factor dB/m	Measure- ment dBuV/m	Limit dBuV/m	Over dB	Detector
1	X	2460.600	91.00	1.06	92.06	Fundamental Frequency		peak
2	*	2461.300	86.33	1.07	87.40	Fundamental Frequency		AVG
3		2483.500	39.07	1.17	40.24	74.00	-33.76	peak
4		2483.500	27.91	1.17	29.08	54.00	-24.92	AVG

Emission Level= Read Level+ Correct Factor

<b>EUT:</b>	Action camera	<b>Model:</b>	9028
<b>Temperature:</b>	25 °C	<b>Relative Humidity:</b>	55%
<b>Test Voltage:</b>	DC 3.7V		
<b>Ant. Pol.</b>	Vertical		
<b>Test Mode:</b>	TX B Mode 2462MHz		
<b>Remark:</b>	N/A		

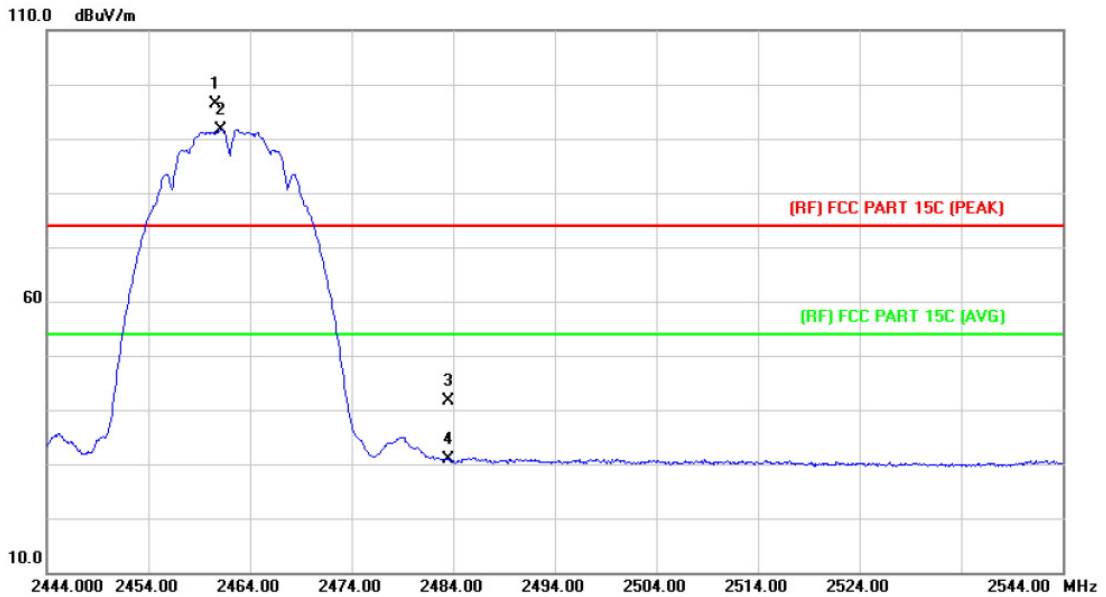

No.	Mk.	Freq. MHz	Reading Level dBuV	Correct Factor dB/m	Measure- ment dBuV/m	Limit dBuV/m	Over dB	Detector
1	X	2460.600	95.35	1.06	96.41	Fundamental Frequency		peak
2	*	2461.200	90.65	1.07	91.72	Fundamental Frequency		AVG
3		2483.500	40.36	1.17	41.53	74.00	-32.47	peak
4		2483.500	29.78	1.17	30.95	54.00	-23.05	AVG

Emission Level= Read Level+ Correct Factor

<b>EUT:</b>	Action camera	<b>Model:</b>	9028
<b>Temperature:</b>	25 °C	<b>Relative Humidity:</b>	55%
<b>Test Voltage:</b>	DC 3.7V		
<b>Ant. Pol.</b>	Horizontal		
<b>Test Mode:</b>	TX G Mode 2412MHz		
<b>Remark:</b>	N/A		

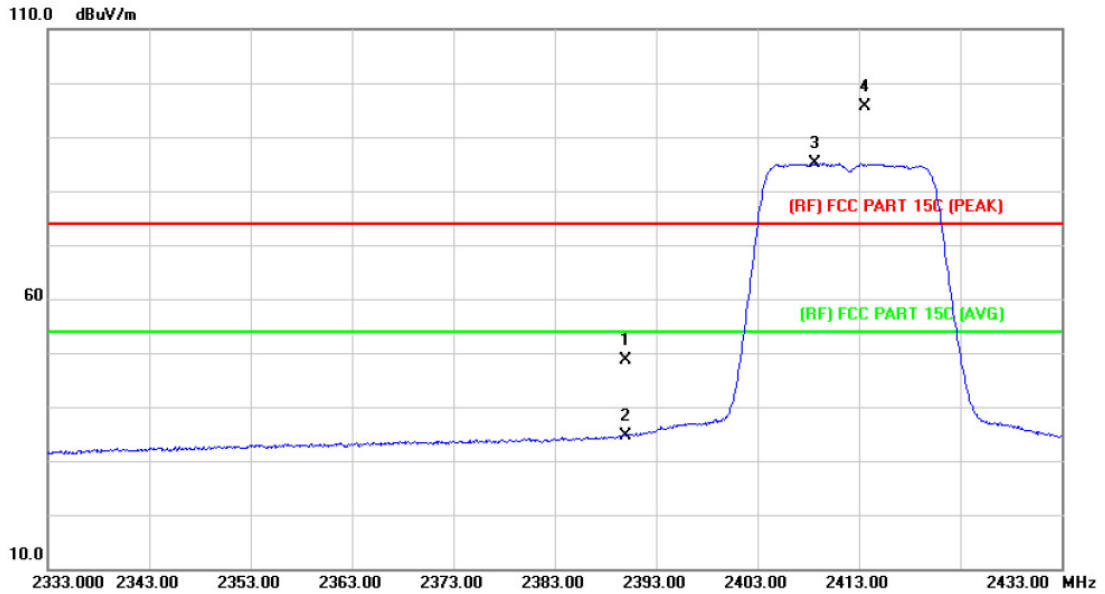

No.	Mk.	Freq. MHz	Reading Level dBuV	Correct Factor dB/m	Measure- ment dBuV/m	Limit dBuV/m	Over dB	Detector
1		2390.000	47.83	0.77	48.60	74.00	-25.40	peak
2		2390.000	33.84	0.77	34.61	54.00	-19.39	AVG
3	*	2408.700	84.33	0.85	85.18	Fundamental Frequency		AVG
4	X	2413.600	94.67	0.86	95.53	Fundamental Frequency		peak

Emission Level= Read Level+ Correct Factor

<b>EUT:</b>	Action camera	<b>Model:</b>	9028
<b>Temperature:</b>	25 °C	<b>Relative Humidity:</b>	55%
<b>Test Voltage:</b>	DC 3.7V		
<b>Ant. Pol.</b>	Vertical		
<b>Test Mode:</b>	TX G Mode 2412MHz		
<b>Remark:</b>	N/A		

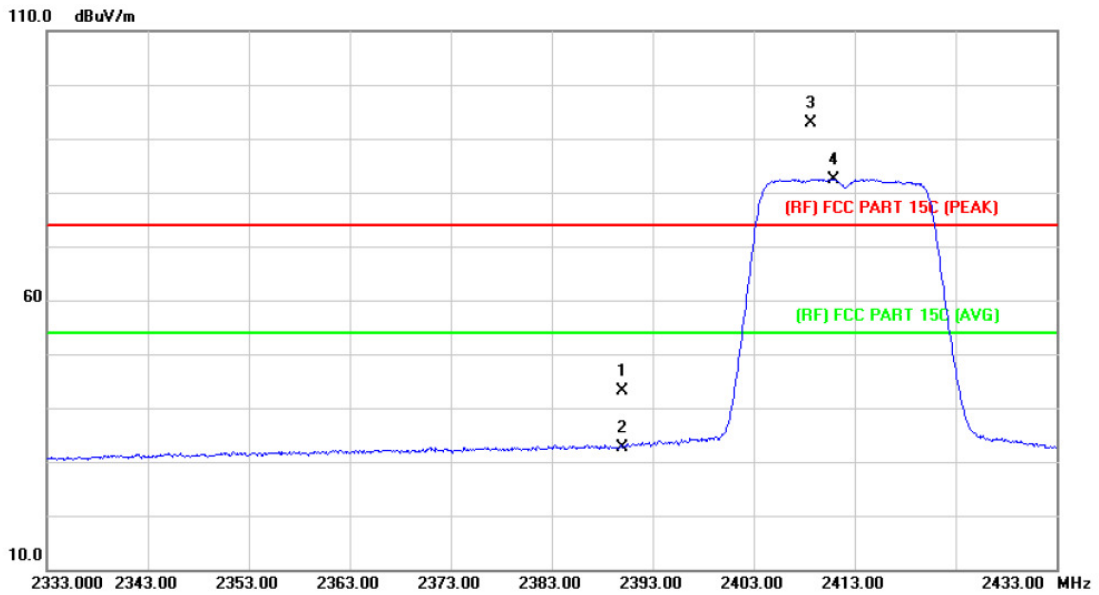

No.	Mk.	Freq.	Reading Level	Correct Factor	Measurement	Limit	Over	Detector
		MHz	dBuV	dB/m	dBuV/m	dBuV/m	dB	
1		2390.000	42.36	0.77	43.13	74.00	-30.87	peak
2		2390.000	31.94	0.77	32.71	54.00	-21.29	AVG
3	X	2408.700	92.01	0.85	92.86	Fundamental Frequency		peak
4	*	2410.900	81.61	0.86	82.47	Fundamental Frequency		AVG

Emission Level= Read Level+ Correct Factor

<b>EUT:</b>	Action camera	<b>Model:</b>	9028
<b>Temperature:</b>	25 °C	<b>Relative Humidity:</b>	55%
<b>Test Voltage:</b>	DC 3.7V		
<b>Ant. Pol.</b>	Horizontal		
<b>Test Mode:</b>	TX G Mode 2462MHz		
<b>Remark:</b>	N/A		

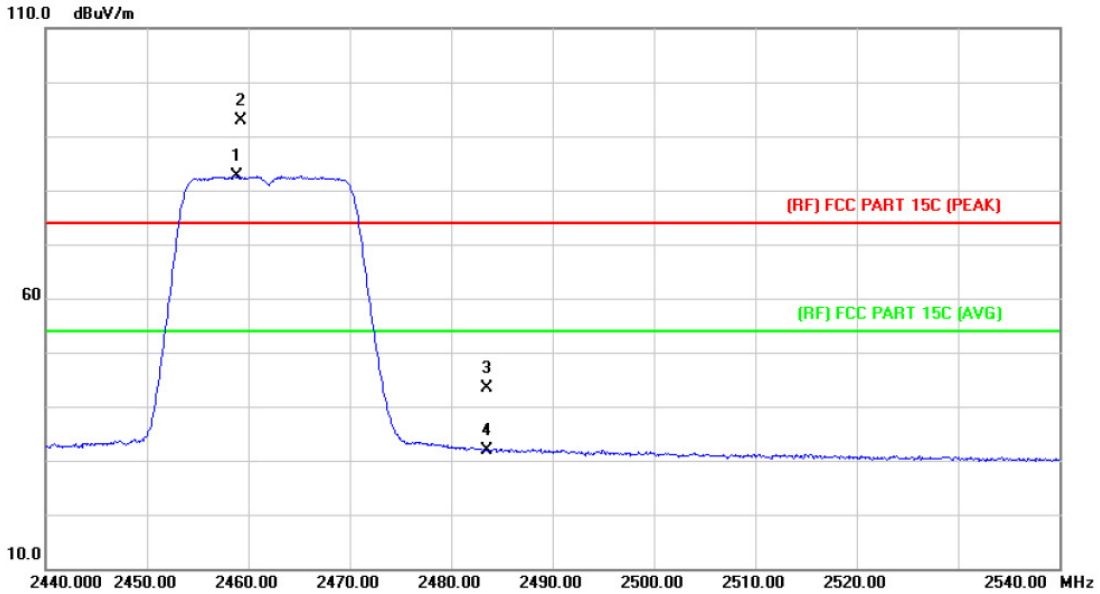

No.	Mk.	Freq. MHz	Reading Level dBuV	Correct Factor dB/m	Measure- ment dBuV/m	Limit dBuV/m	Over dB	Detector
1	*	2458.800	81.53	1.06	82.59	Fundamental Frequency		AVG
2	X	2459.300	91.70	1.06	92.76	Fundamental Frequency		peak
3		2483.500	42.20	1.17	43.37	74.00	-30.63	peak
4		2483.500	30.77	1.17	31.94	54.00	-22.06	AVG

Emission Level= Read Level+ Correct Factor

<b>EUT:</b>	Action camera	<b>Model:</b>	9028
<b>Temperature:</b>	25 °C	<b>Relative Humidity:</b>	55%
<b>Test Voltage:</b>	DC 3.7V		
<b>Ant. Pol.</b>	Vertical		
<b>Test Mode:</b>	TX G Mode 2462MHz		
<b>Remark:</b>	N/A		

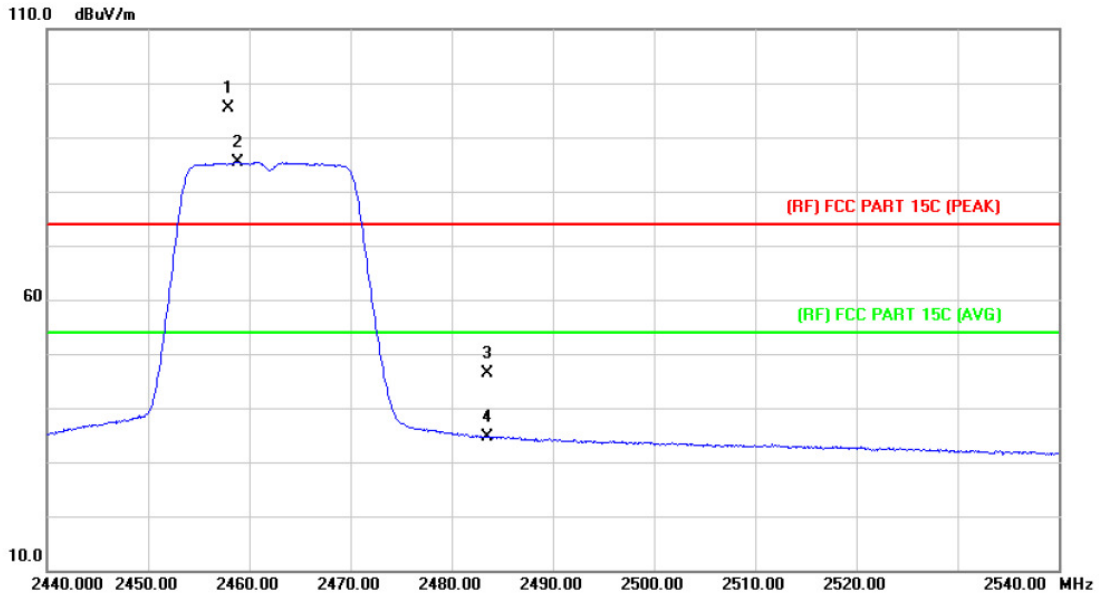

No.	Mk.	Freq. MHz	Reading Level dBuV	Correct Factor dB/m	Measure- ment dBuV/m	Limit dBuV/m	Over dB	Detector
1	X	2457.900	94.35	1.06	95.41	Fundamental Frequency		peak
2	*	2458.800	84.38	1.06	85.44	Fundamental Frequency		AVG
3		2483.500	45.28	1.17	46.45	74.00	-27.55	peak
4		2483.500	33.57	1.17	34.74	54.00	-19.26	AVG

Emission Level= Read Level+ Correct Factor

<b>EUT:</b>	Action camera	<b>Model:</b>	9028
<b>Temperature:</b>	25 °C	<b>Relative Humidity:</b>	55%
<b>Test Voltage:</b>	DC 3.7V		
<b>Ant. Pol.</b>	Horizontal		
<b>Test Mode:</b>	TX N(HT20) Mode 2412MHz		
<b>Remark:</b>	N/A		

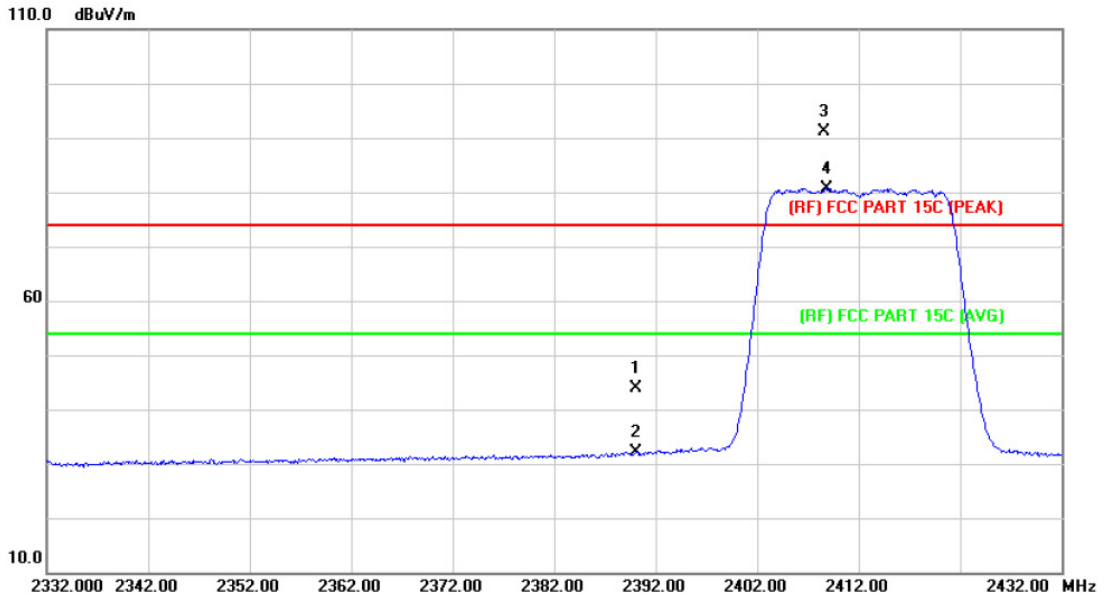

No.	Mk.	Freq. MHz	Reading Level dBuV	Correct Factor dB/m	Measure- ment dBuV/m	Limit dBuV/m	Over dB	Detector
1		2390.000	43.19	0.77	43.96	74.00	-30.04	peak
2		2390.000	31.26	0.77	32.03	54.00	-21.97	AVG
3	X	2408.600	90.24	0.85	91.09	Fundamental Frequency		peak
4	*	2408.900	79.90	0.85	80.75	Fundamental Frequency		AVG

Emission Level= Read Level+ Correct Factor

<b>EUT:</b>	Action camera	<b>Model:</b>	9028
<b>Temperature:</b>	25 °C	<b>Relative Humidity:</b>	55%
<b>Test Voltage:</b>	DC 3.7V		
<b>Ant. Pol.</b>	Vertical		
<b>Test Mode:</b>	TX N(HT20) Mode 2412MHz		
<b>Remark:</b>	N/A		

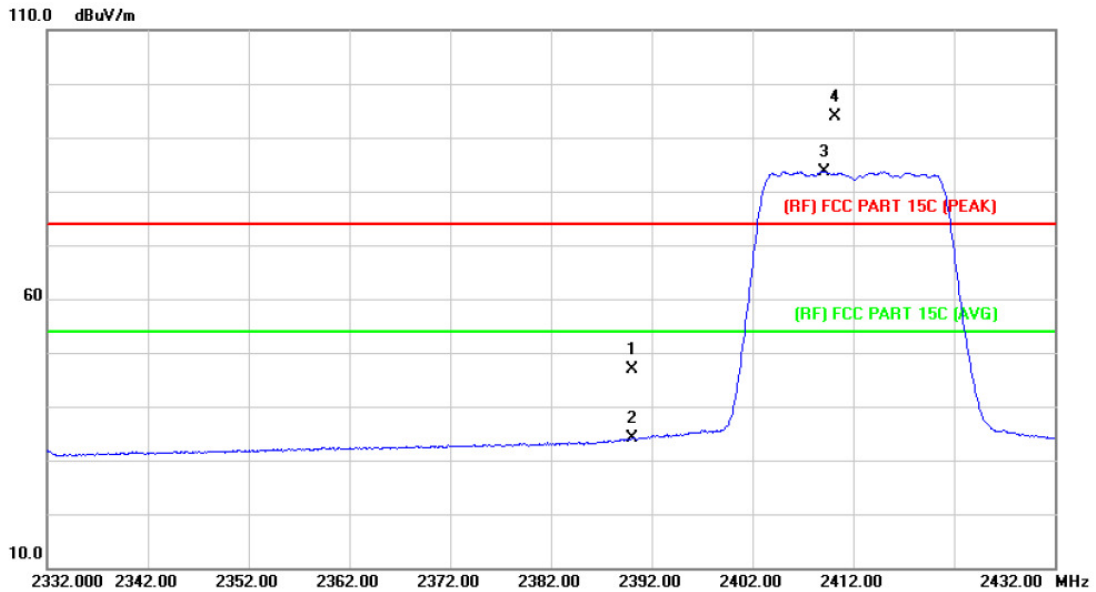

No.	Mk.	Freq. MHz	Reading Level dBuV	Correct Factor dB/m	Measure- ment dBuV/m	Limit dBuV/m	Over dB	Detector
1		2390.000	46.10	0.77	46.87	74.00	-27.13	peak
2		2390.000	33.36	0.77	34.13	54.00	-19.87	AVG
3	*	2409.100	82.85	0.85	83.70	Fundamental Frequency		AVG
4	X	2410.200	93.14	0.85	93.99	Fundamental Frequency		peak

Emission Level= Read Level+ Correct Factor

<b>EUT:</b>	Action camera	<b>Model:</b>	9028
<b>Temperature:</b>	25 °C	<b>Relative Humidity:</b>	55%
<b>Test Voltage:</b>	DC 3.7V		
<b>Ant. Pol.</b>	Horizontal		
<b>Test Mode:</b>	TX N(HT20) Mode 2462MHz		
<b>Remark:</b>	N/A		

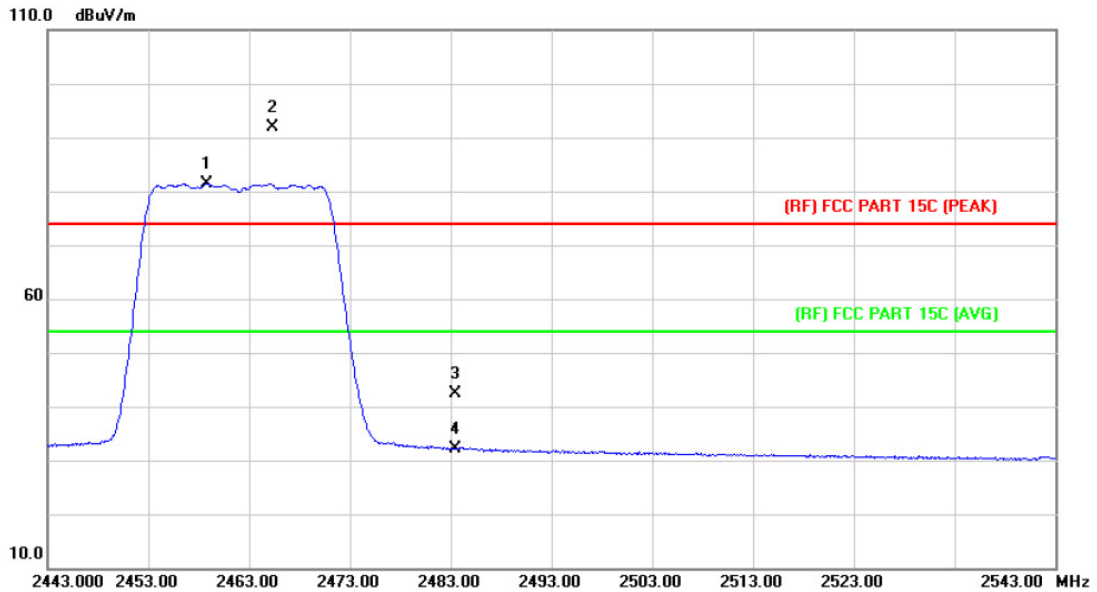

No.	Mk.	Freq. MHz	Reading Level dBuV	Correct Factor dB/m	Measure- ment dBuV/m	Limit dBuV/m	Over dB	Detector
1	*	2458.800	80.27	1.06	81.33	Fundamental Frequency		AVG
2	X	2465.300	90.79	1.09	91.88	Fundamental Frequency		peak
3		2483.500	41.28	1.17	42.45	74.00	-31.55	peak
4		2483.500	30.92	1.17	32.09	54.00	-21.91	AVG

Emission Level= Read Level+ Correct Factor

<b>EUT:</b>	Action camera	<b>Model:</b>	9028
<b>Temperature:</b>	25 °C	<b>Relative Humidity:</b>	55%
<b>Test Voltage:</b>	DC 3.7V		
<b>Ant. Pol.</b>	Vertical		
<b>Test Mode:</b>	TX N(HT20) Mode 2462MHz		
<b>Remark:</b>	N/A		

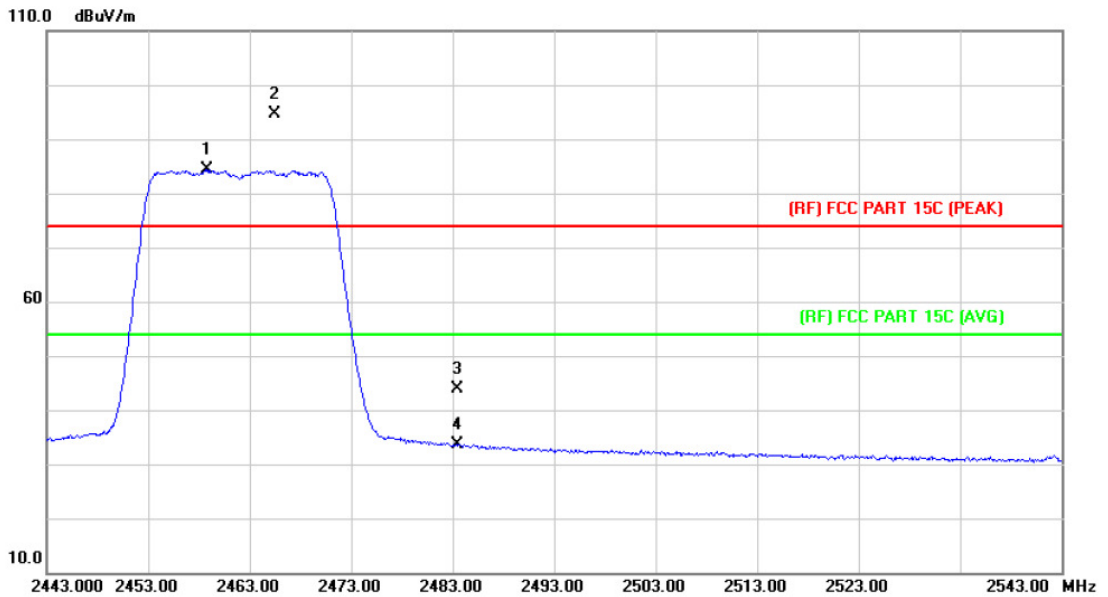

No.	Mk.	Freq. MHz	Reading Level dBuV	Correct Factor dB/m	Measure- ment dBuV/m	Limit dBuV/m	Over dB	Detector
1	*	2458.800	83.29	1.06	84.35	Fundamental Frequency		AVG
2	X	2465.500	93.48	1.09	94.57	Fundamental Frequency		peak
3		2483.500	42.77	1.17	43.94	74.00	-30.06	peak
4		2483.500	32.46	1.17	33.63	54.00	-20.37	AVG

Emission Level= Read Level+ Correct Factor

<b>EUT:</b>	Action camera	<b>Model:</b>	9028
<b>Temperature:</b>	25 °C	<b>Relative Humidity:</b>	55%
<b>Test Voltage:</b>	DC 3.7V		
<b>Ant. Pol.</b>	Horizontal		
<b>Test Mode:</b>	TX N(HT40) Mode 2422MHz		
<b>Remark:</b>	N/A		

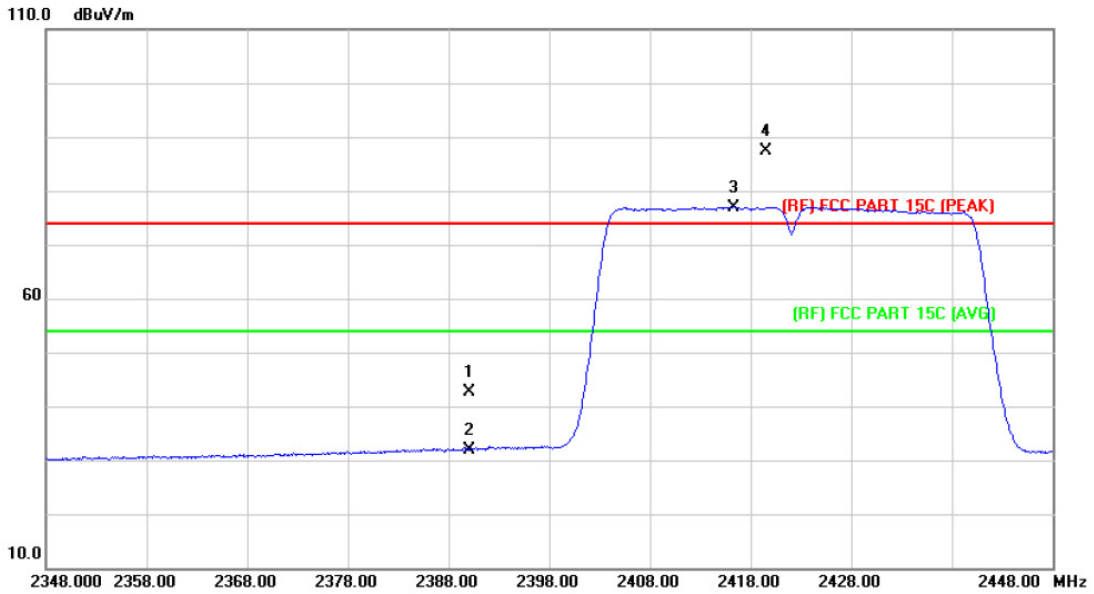

No.	Mk.	Freq. MHz	Reading Level dBuV	Correct Factor dB/m	Measure- ment dBuV/m	Limit dBuV/m	Over dB	Detector
1		2390.000	41.78	0.77	42.55	74.00	-31.45	peak
2		2390.000	31.19	0.77	31.96	54.00	-22.04	AVG
3	*	2416.300	76.12	0.88	77.00	Fundamental Frequency		AVG
4	X	2419.600	86.44	0.89	87.33	Fundamental Frequency		peak

Emission Level= Read Level+ Correct Factor

<b>EUT:</b>	Action camera	<b>Model:</b>	9028
<b>Temperature:</b>	25 °C	<b>Relative Humidity:</b>	55%
<b>Test Voltage:</b>	DC 3.7V		
<b>Ant. Pol.</b>	Vertical		
<b>Test Mode:</b>	TX N(HT40) Mode 2422MHz		
<b>Remark:</b>	N/A		

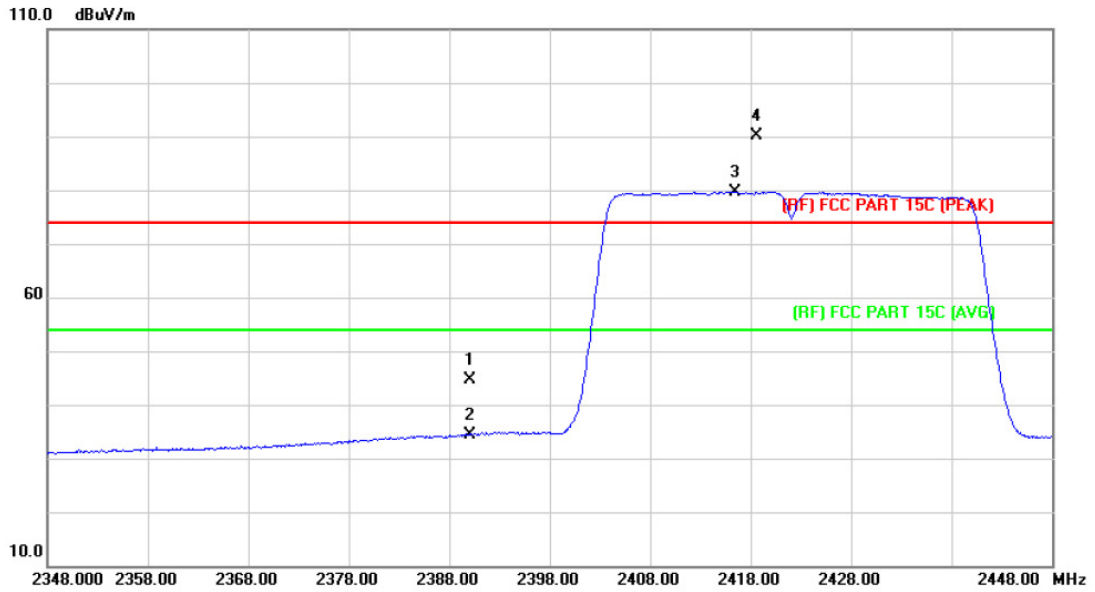

No.	Mk.	Freq. MHz	Reading Level dBuV	Correct Factor dB/m	Measure- ment dBuV/m	Limit dBuV/m	Over dB	Detector
1		2390.000	43.95	0.77	44.72	Fundamental Frequency		peak
2		2390.000	33.63	0.77	34.40	Fundamental Frequency		AVG
3	*	2416.400	78.77	0.88	79.65	54.00	25.65	AVG
4	X	2418.600	89.16	0.89	90.05	74.00	16.05	peak

Emission Level= Read Level+ Correct Factor

<b>EUT:</b>	Action camera	<b>Model:</b>	9028
<b>Temperature:</b>	25 °C	<b>Relative Humidity:</b>	55%
<b>Test Voltage:</b>	DC 3.7V		
<b>Ant. Pol.</b>	Horizontal		
<b>Test Mode:</b>	TX N(HT40) Mode 2452MHz		
<b>Remark:</b>	N/A		

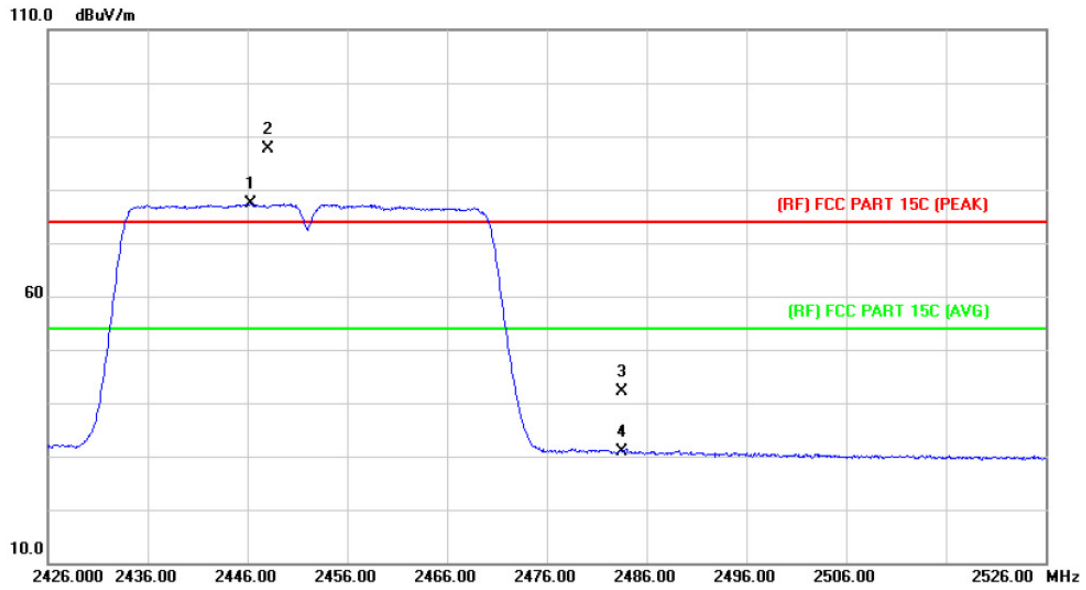

No.	Mk.	Freq. MHz	Reading Level dBuV	Correct Factor dB/m	Measure- ment dBuV/m	Limit dBuV/m	Over dB	Detector
1	*	2446.300	76.31	1.01	77.32	Fundamental Frequency		AVG
2	X	2448.000	86.53	1.02	87.55	Fundamental Frequency		peak
3		2483.500	41.07	1.17	42.24	74.00	-31.76	peak
4		2483.500	29.75	1.17	30.92	54.00	-23.08	AVG

Emission Level= Read Level+ Correct Factor

<b>EUT:</b>	Action camera	<b>Model:</b>	9028
<b>Temperature:</b>	25 °C	<b>Relative Humidity:</b>	55%
<b>Test Voltage:</b>	DC 3.7V		
<b>Ant. Pol.</b>	Vertical		
<b>Test Mode:</b>	TX N(HT40) Mode 2452MHz		
<b>Remark:</b>	N/A		

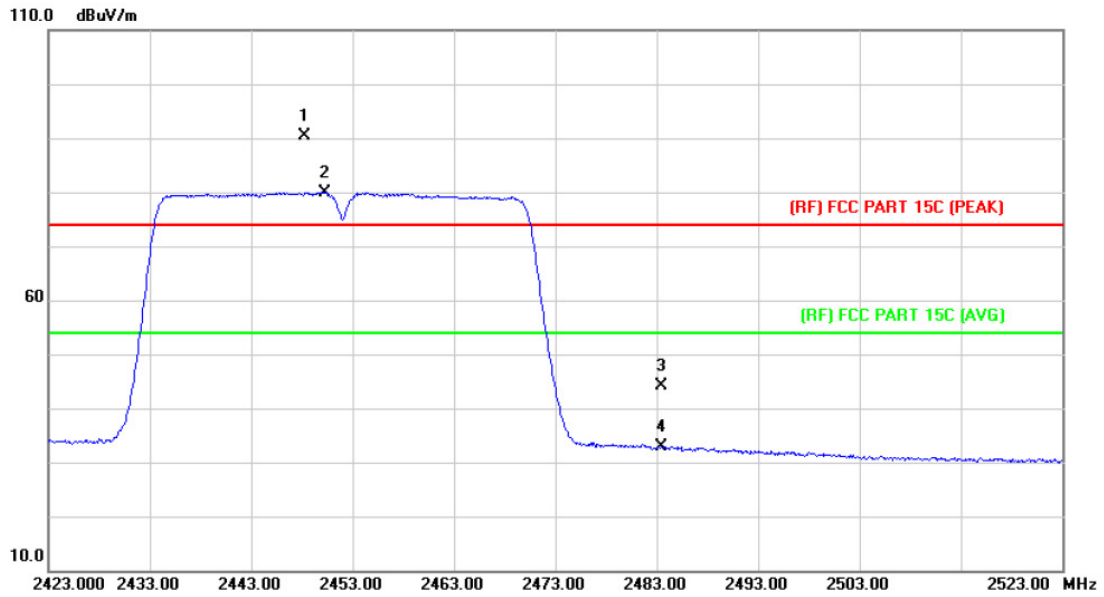

No.	Mk.	Freq. MHz	Reading Level dBuV	Correct Factor dB/m	Measure- ment dBuV/m	Limit dBuV/m	Over dB	Detector
1	X	2448.300	89.34	1.02	90.36	Fundamental Frequency		peak
2	*	2450.300	78.92	1.02	79.94	Fundamental Frequency		AVG
3		2483.500	42.91	1.17	44.08	74.00	-29.92	peak
4		2483.500	31.62	1.17	32.79	54.00	-21.21	AVG

Emission Level= Read Level+ Correct Factor

**(2) Conducted Test**

<b>EUT:</b>	Action camera	<b>Model:</b>	9028
<b>Temperature:</b>	25 °C	<b>Relative Humidity:</b>	55%
<b>Test Voltage:</b>	DC 3.7V		
<b>Test Mode:</b>	TX B Mode 2412MHz / TX B Mode 2462MHz		
<b>Remark:</b>	The EUT is programed in continuously transmitting mode		

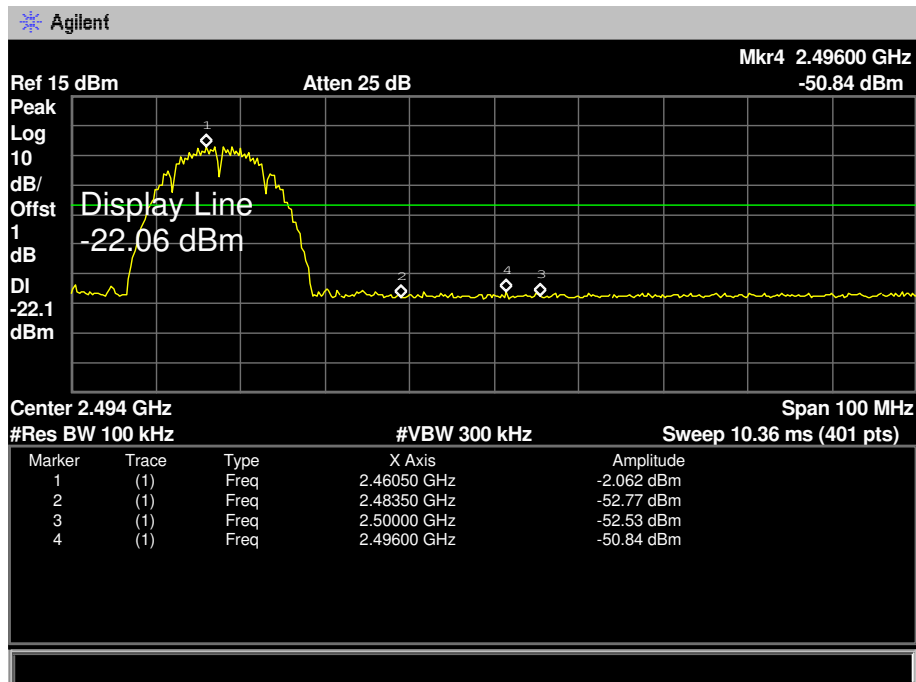
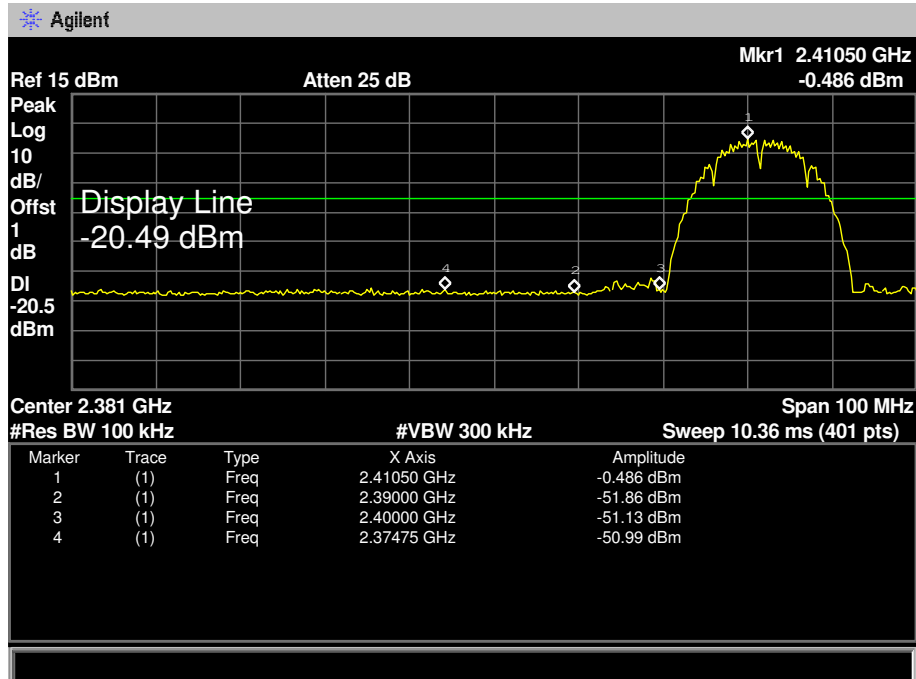

<b>EUT:</b>	Action camera	<b>Model:</b>	9028
<b>Temperature:</b>	25 °C	<b>Relative Humidity:</b>	55%
<b>Test Voltage:</b>	DC 3.7V		
<b>Test Mode:</b>	TX G Mode 2412MHz / TX G Mode 2462MHz		
<b>Remark:</b>	The EUT is programed in continuously transmitting mode		

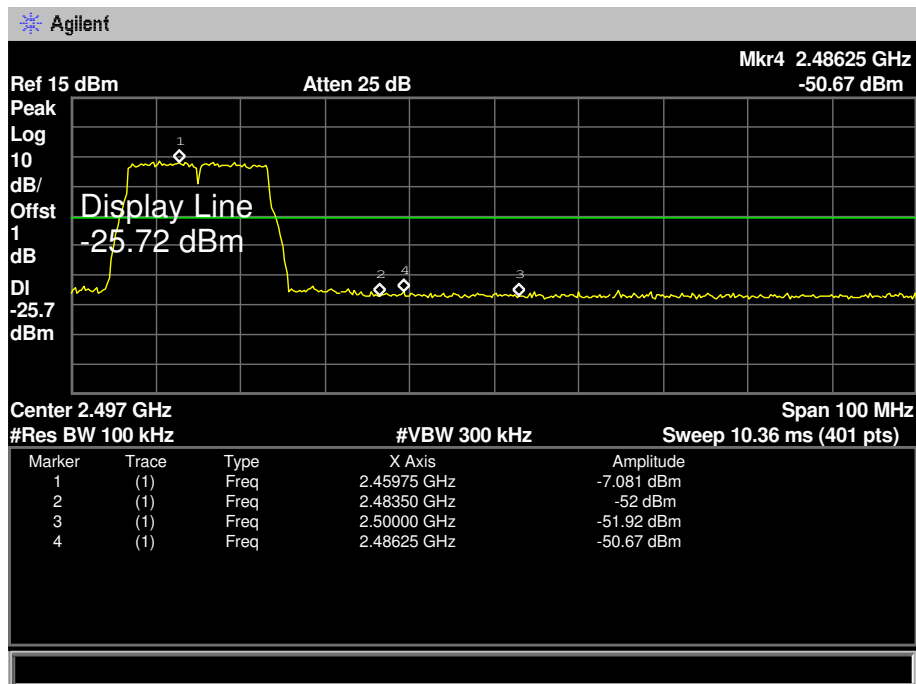
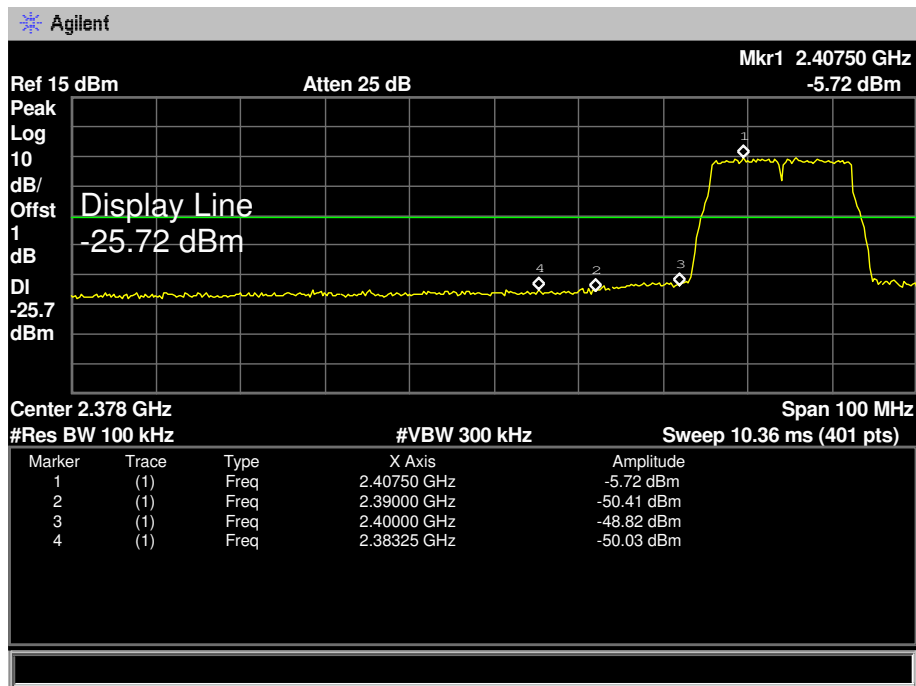

<b>EUT:</b>	Action camera	<b>Model:</b>	9028
<b>Temperature:</b>	25 °C	<b>Relative Humidity:</b>	55%
<b>Test Voltage:</b>	DC 3.7V		
<b>Test Mode:</b>	TX N(HT20) Mode 2412MHz / TX N(HT20) Mode 2462MHz		
<b>Remark:</b>	The EUT is programed in continuously transmitting mode		

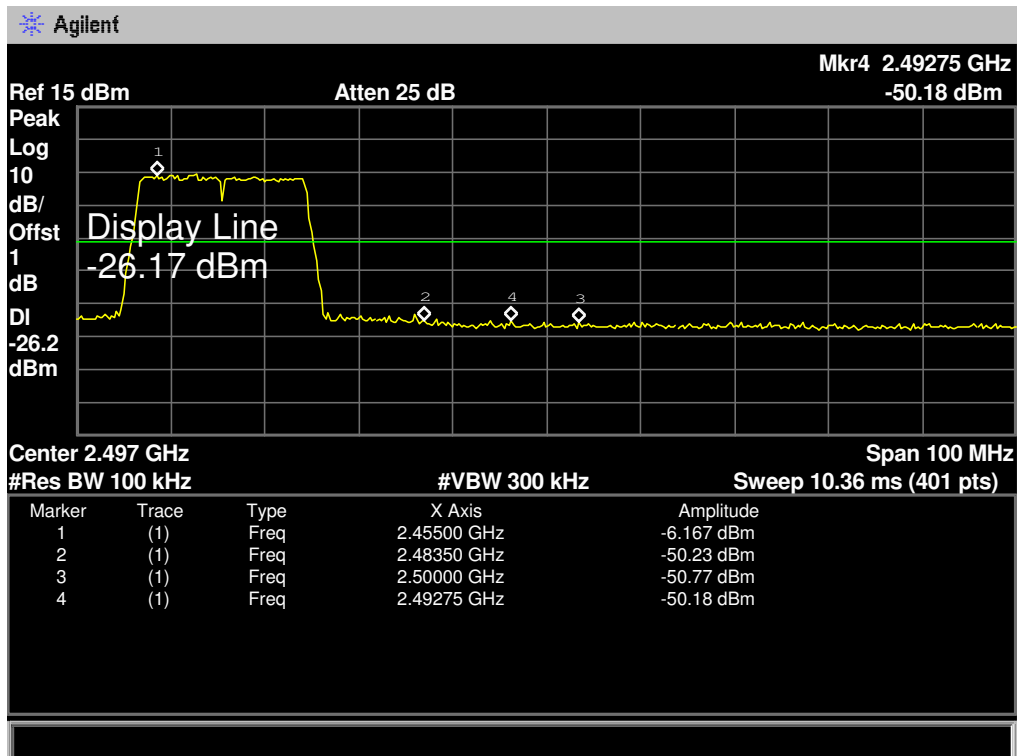
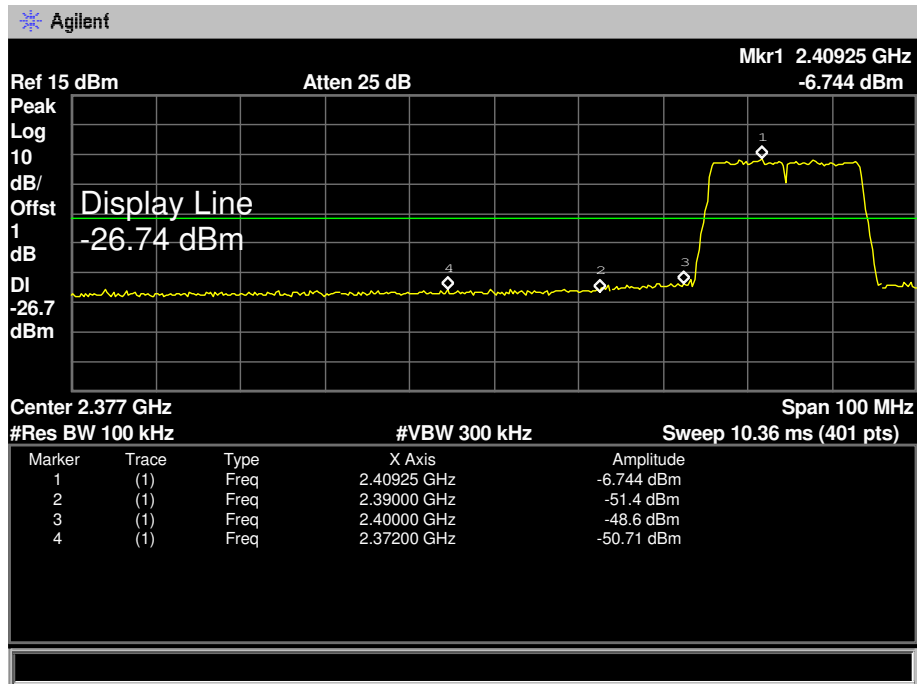

<b>EUT:</b>	Action camera	<b>Model:</b>	9028
<b>Temperature:</b>	25 °C	<b>Relative Humidity:</b>	55%
<b>Test Voltage:</b>	DC 3.7V		
<b>Test Mode:</b>	TX N(HT40) Mode 2422MHz / TX N(HT40) Mode 2452MHz		
<b>Remark:</b>	The EUT is programed in continuously transmitting mode		

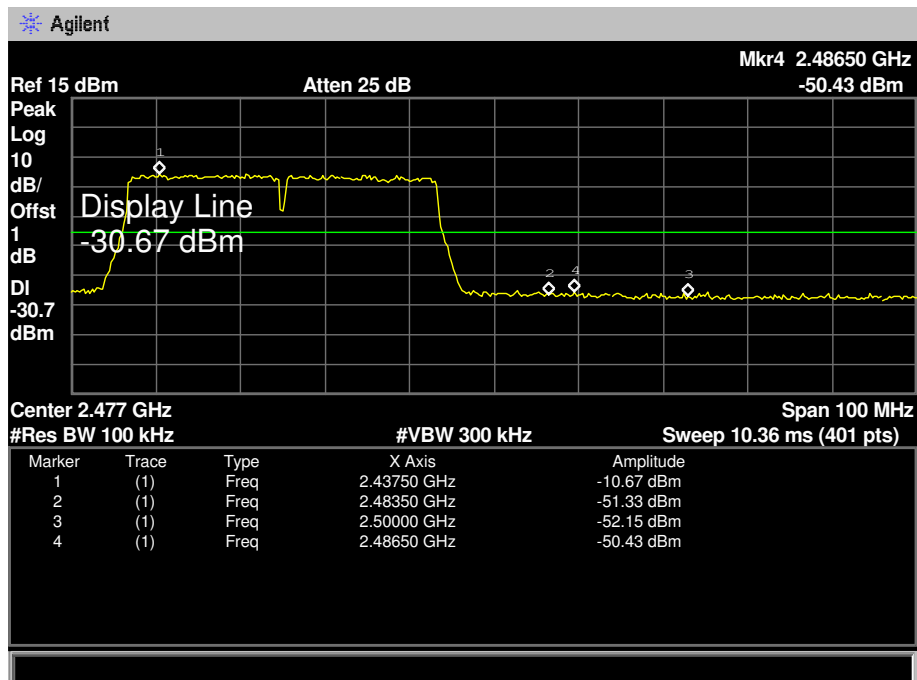
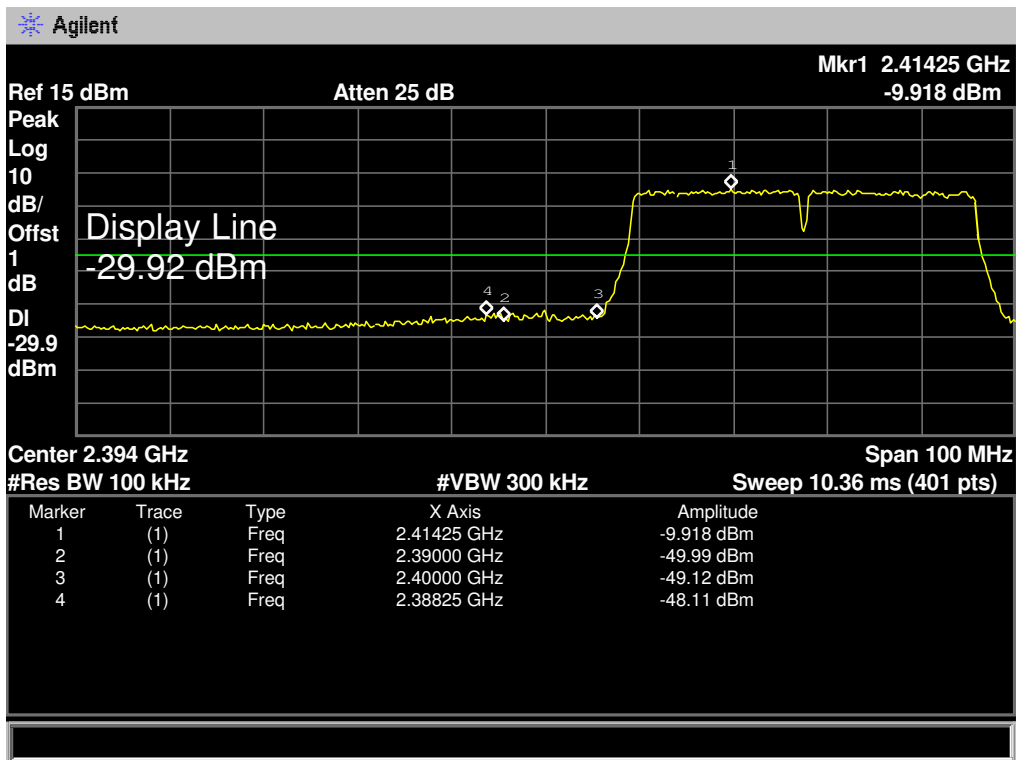

## 7. Bandwidth Test

### 7.1 Test Standard and Limit

#### 7.1.1 Test Standard

FCC Part 15.247 (a)(2)

#### 7.1.2 Test Limit

FCC Part 15 Subpart C(15.247)/RSS-210		
Test Item	Limit	Frequency Range(MHz)
Bandwidth	$\geq 500$ KHz (6dB bandwidth)	2400~2483.5

### 7.2 Test Setup

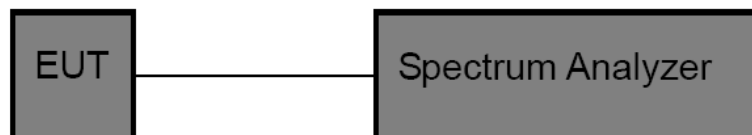

### 7.3 Test Procedure

- (1) The EUT was directly connected to the spectrum analyzer and antenna output port as show in the block diagram above.
- (2) The bandwidth is measured at an amplitude level reduced 6dB from the reference level. The reference level is the level of the highest amplitude signal observed from the transmitter at the fundamental frequency. Once the reference level is established, the equipment is conditioned with typical modulating signal to produce the worst –case (i.e the widest) bandwidth.
- (3) Measure the channel separation the spectrum analyzer was set to Resolution Bandwidth:100 kHz, and Video Bandwidth:300 kHz, Detector: Peak, Sweep Time set auto.

### 7.4 EUT Operating Condition

The EUT was set to continuously transmitting in each mode and low, middle and high channel for the test.

7.5 Test Data

<b>EUT:</b>	Action camera	<b>Model:</b>	9028
<b>Temperature:</b>	25 °C	<b>Relative Humidity:</b>	55%
<b>Test Voltage:</b>	DC 3.7V		
<b>Test Mode:</b>	TX 802.11B Mode		
<b>Channel frequency (MHz)</b>	<b>6dB Bandwidth (MHz)</b>	<b>99% Bandwidth (MHz)</b>	<b>Limit (MHz)</b>
2412	10.019	12.8941	>=0.5
2437	10.043	12.8316	
2462	9.1200	12.7439	
<b>802.11B Mode</b>			
<b>2412 MHz</b>			

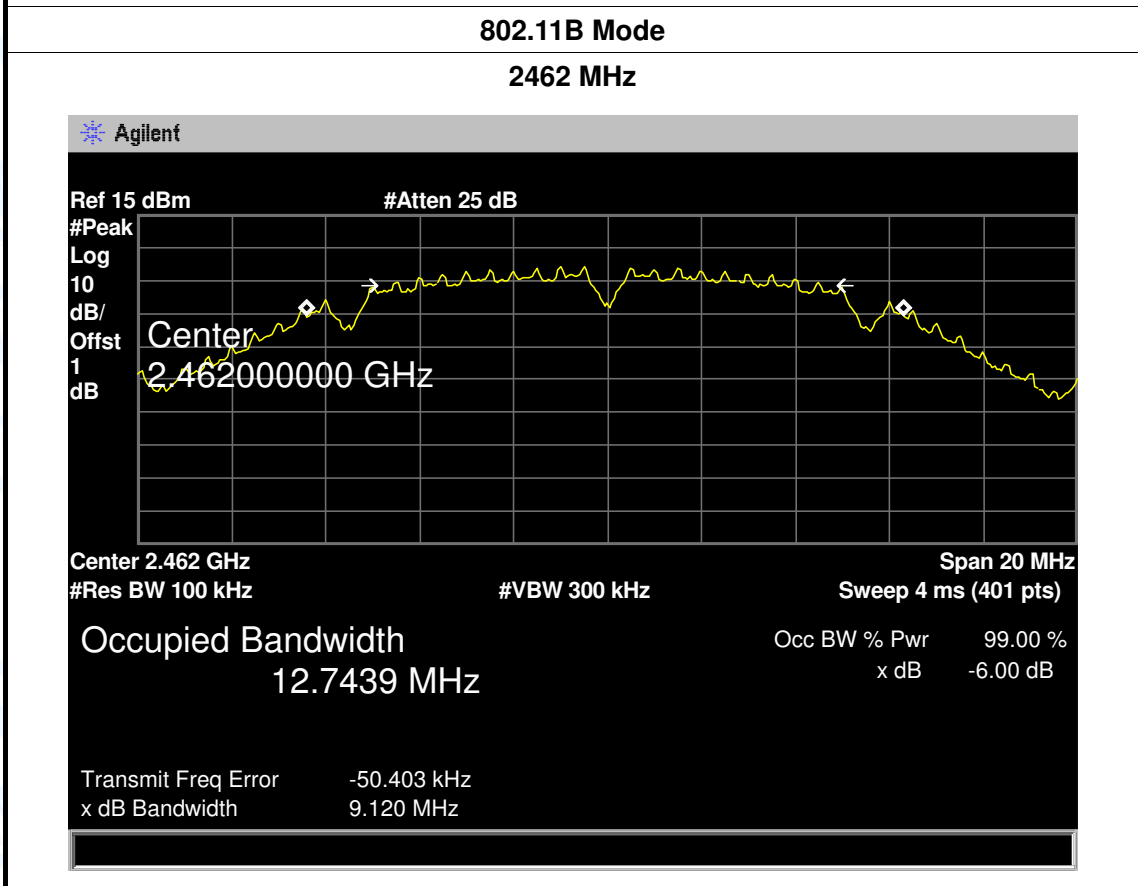
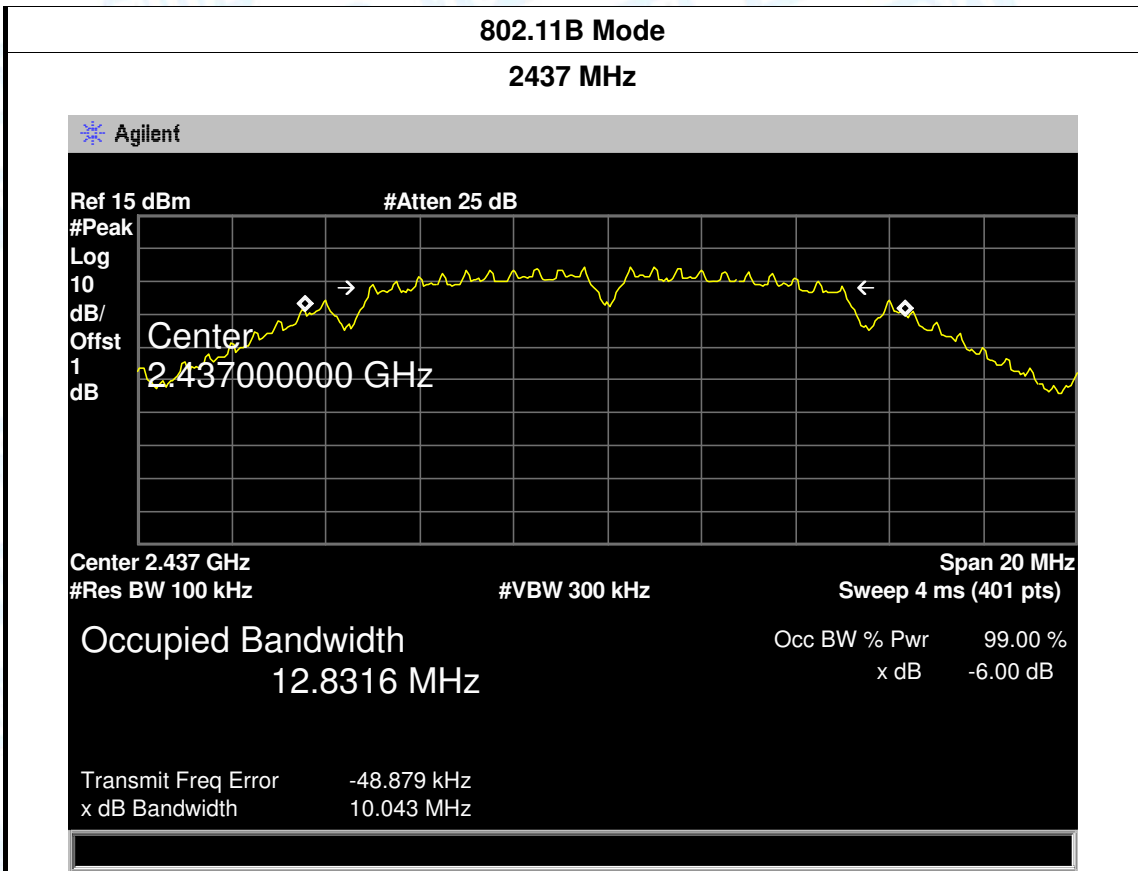

<b>EUT:</b>	Action camera	<b>Model:</b>	9028
<b>Temperature:</b>	25 °C	<b>Relative Humidity:</b>	55%
<b>Test Voltage:</b>	DC 3.7V		
<b>Test Mode:</b>	TX 802.11G Mode		
<b>Channel frequency (MHz)</b>	<b>6dB Bandwidth (MHz)</b>	<b>99% Bandwidth (MHz)</b>	<b>Limit (MHz)</b>
2412	15.083	16.3551	>=0.5
2437	14.852	16.3588	
2462	15.836	16.3434	
<b>802.11G Mode</b>			
<b>2412 MHz</b>			
<p>Agilent</p> <p>Ref 15 dBm #Atten 25 dB</p> <p>#Peak Log 10 dB/Offst 1 dB</p> <p>Center 2.412000000 GHz</p> <p>Center 2.412 GHz #Res BW 100 kHz #VBW 300 kHz Span 20 MHz Sweep 4 ms (401 pts)</p> <p>Occupied Bandwidth 16.3551 MHz Occ BW % Pwr 99.00% x dB -6.00 dB</p> <p>Transmit Freq Error -10.707 kHz x dB Bandwidth 15.083 MHz</p>			

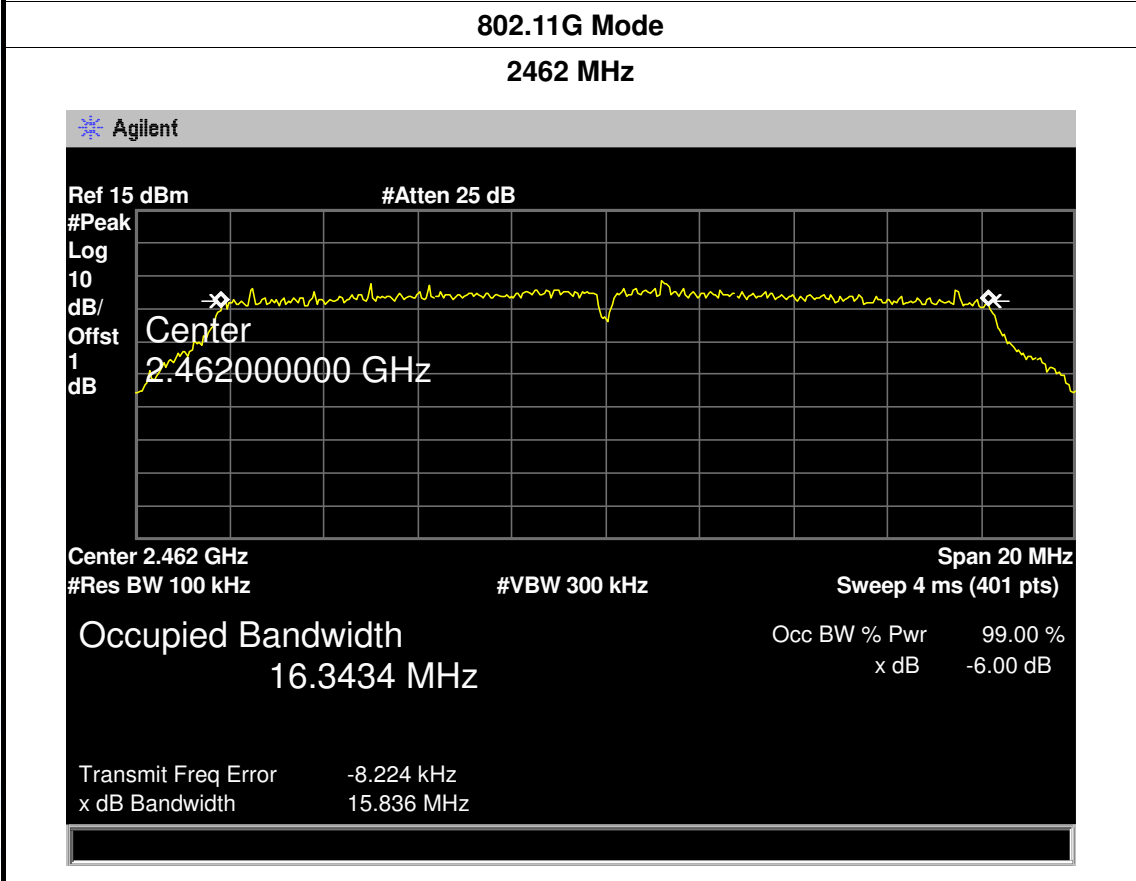
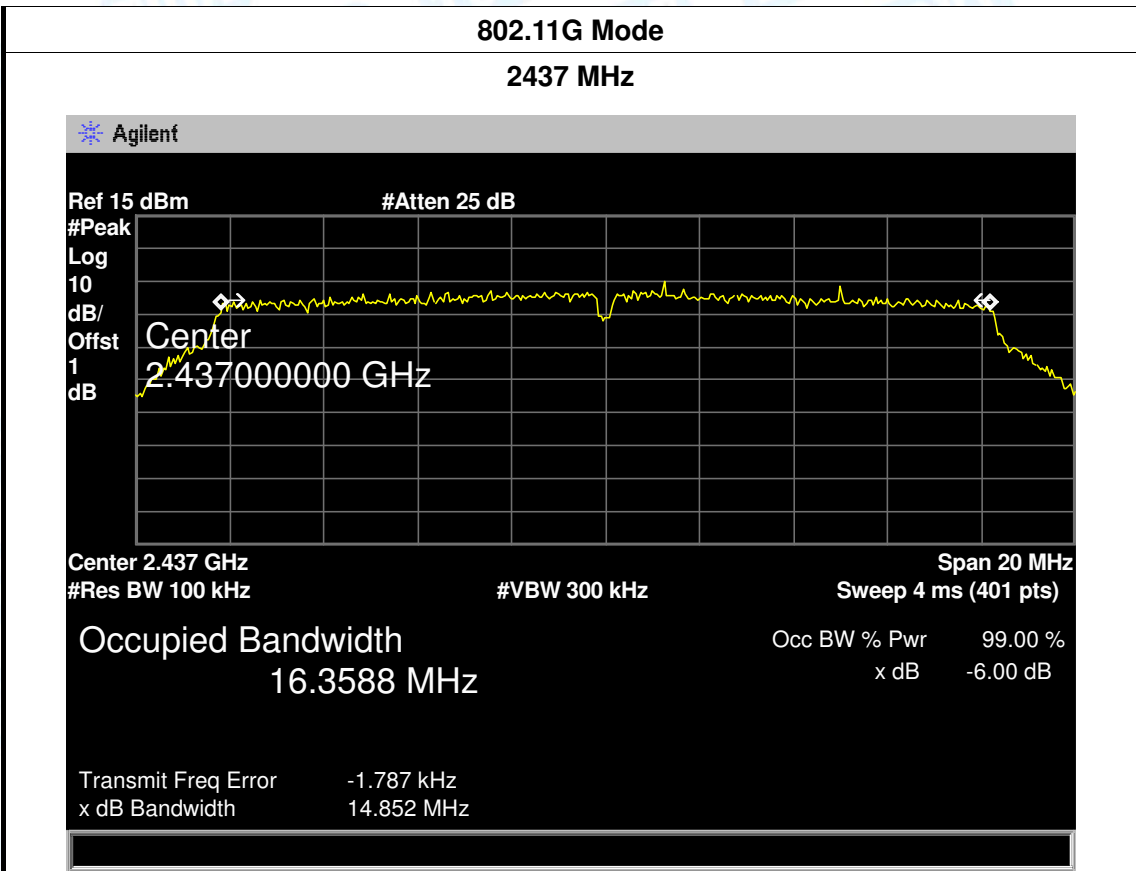

<b>EUT:</b>	Action camera	<b>Model:</b>	9028
<b>Temperature:</b>	25 °C	<b>Relative Humidity:</b>	55%
<b>Test Voltage:</b>	DC 3.7V		
<b>Test Mode:</b>	TX 802.11N(HT20) Mode		
<b>Channel frequency (MHz)</b>	<b>6dB Bandwidth (MHz)</b>	<b>99% Bandwidth (MHz)</b>	<b>Limit (MHz)</b>
2412	17.377	17.5215	>=0.5
2437	17.005	17.4929	
2462	17.317	17.4893	
<b>802.11N(HT20) Mode</b>			
<b>2412 MHz</b>			
<p>Agilent</p> <p>Ref 15 dBm #Atten 25 dB</p> <p>#Peak Log 10 dB/Offst 1 dB</p> <p>Center 2.412000000 GHz</p> <p>Center 2.412 GHz #Res BW 100 kHz #VBW 300 kHz Span 20 MHz Sweep 4 ms (401 pts)</p> <p><b>Occupied Bandwidth 17.5215 MHz</b></p> <p>Occ BW % Pwr 99.00 % x dB -6.00 dB</p> <p>Transmit Freq Error 2.025 kHz x dB Bandwidth 17.377 MHz</p>			

**802.11N(HT20) Mode**

**2437 MHz**

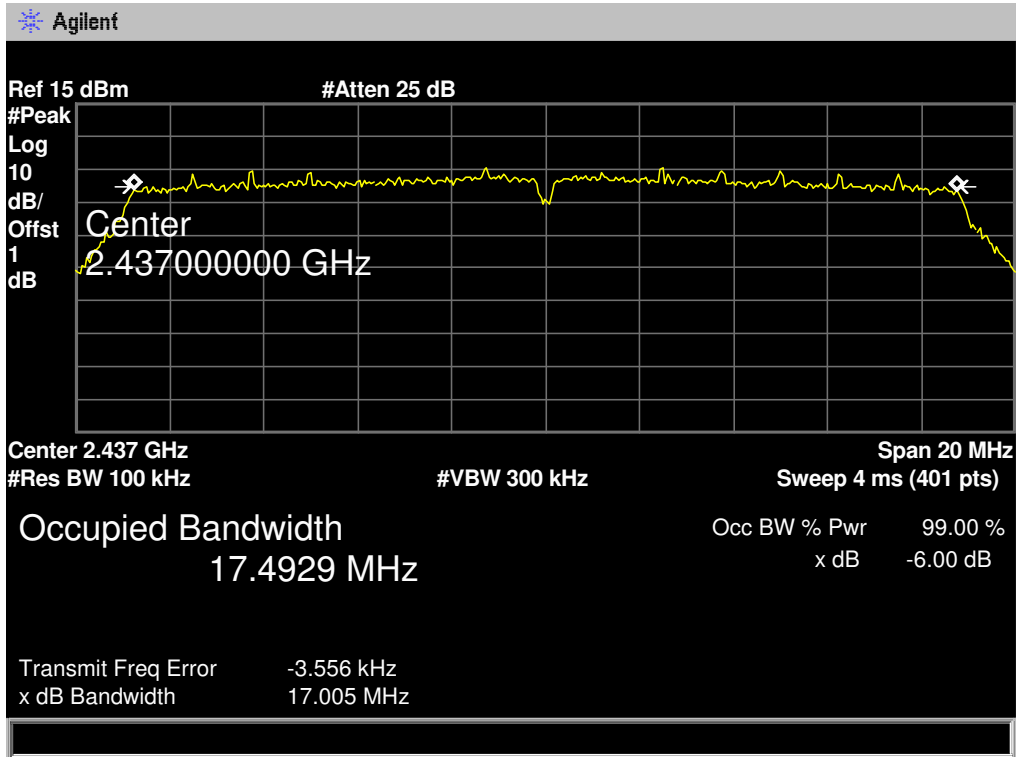

**802.11N(HT20) Mode**

**2462 MHz**

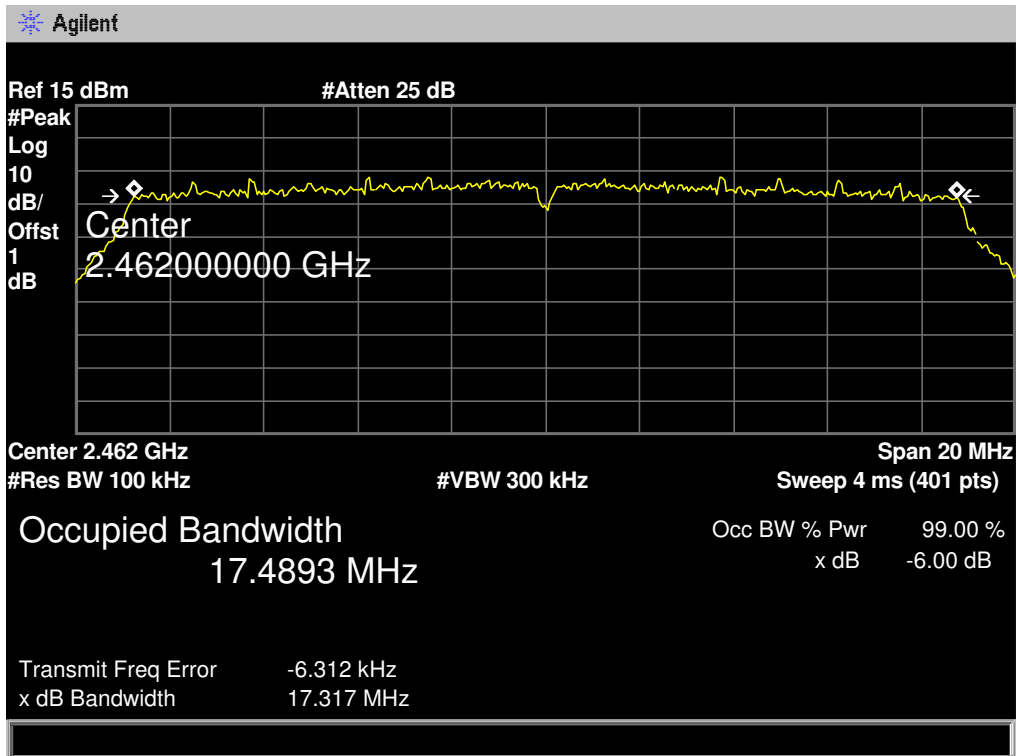

<b>EUT:</b>	Action camera	<b>Model:</b>	9028
<b>Temperature:</b>	25 °C	<b>Relative Humidity:</b>	55%
<b>Test Voltage:</b>	DC 3.7V		
<b>Test Mode:</b>	TX 802.11N(HT40) Mode		
<b>Channel frequency (MHz)</b>	<b>6dB Bandwidth (MHz)</b>	<b>99% Bandwidth (MHz)</b>	<b>Limit (MHz)</b>
2422	35.203	35.6900	≥0.5
2437	35.199	35.6514	
2452	35.169	35.7334	

**802.11N(HT40) Mode**

**2422 MHz**

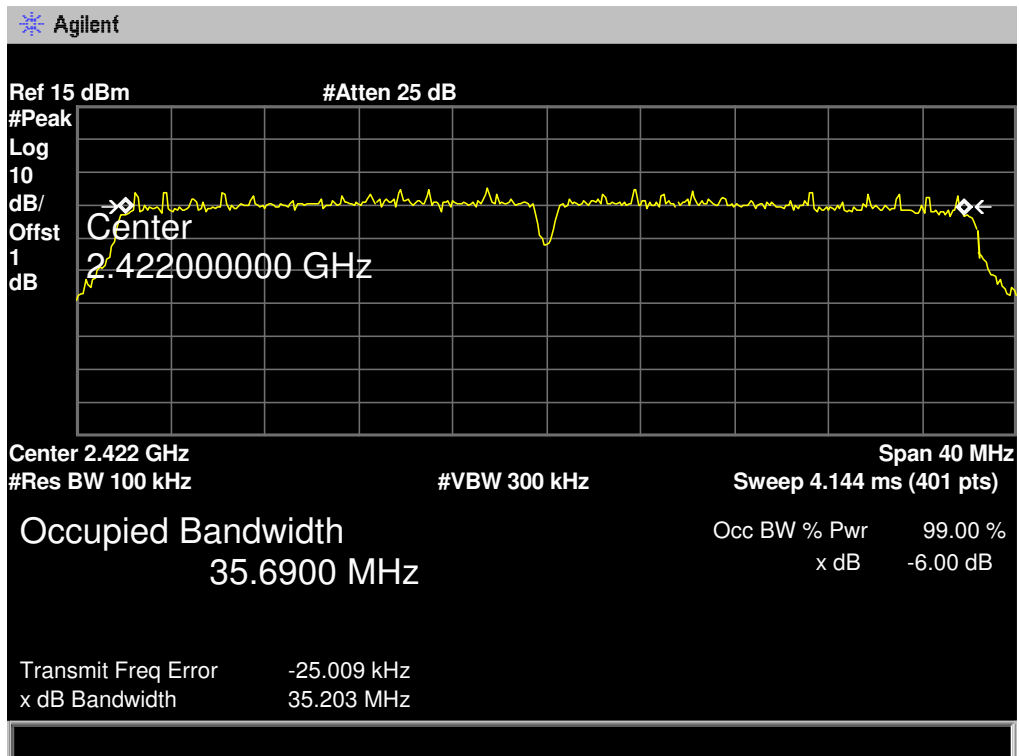

802.11N(HT40) Mode

2437 MHz

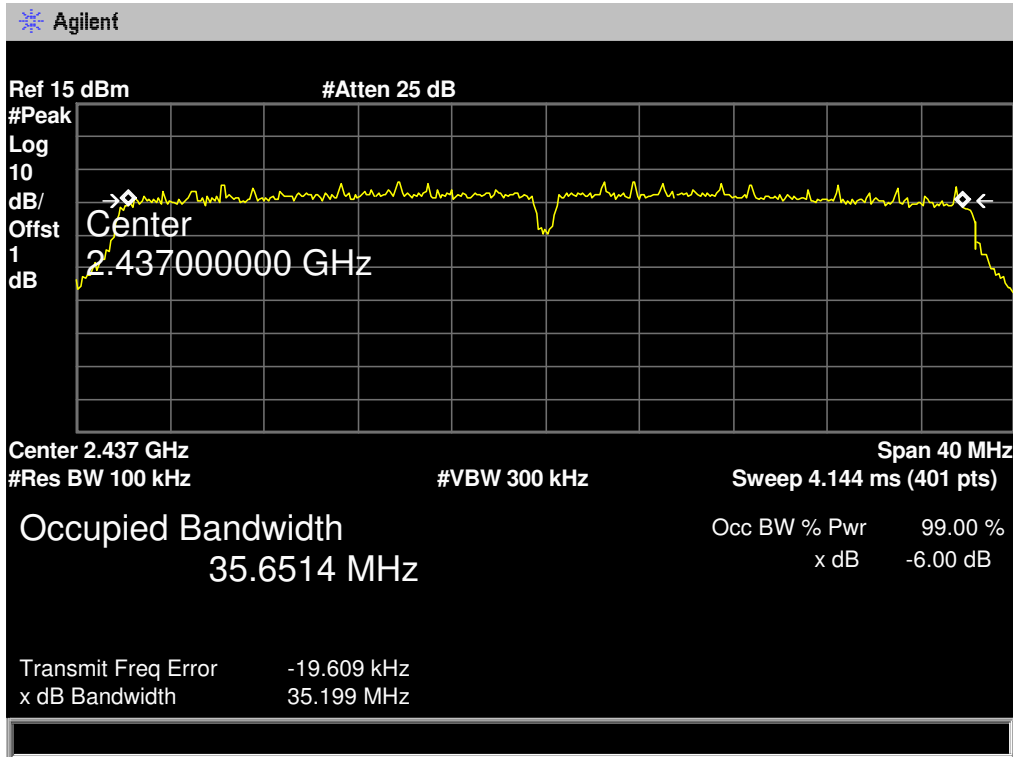

802.11N(HT40) Mode

2452 MHz

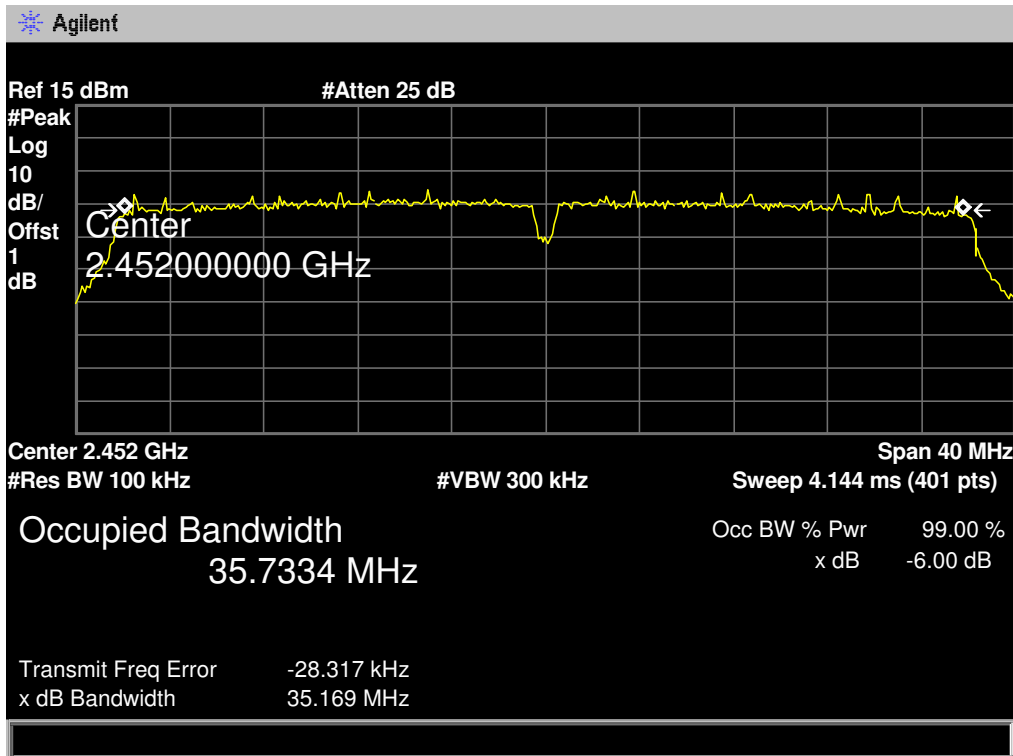

## 8. Peak Output Power Test

### 8.1 Test Standard and Limit

- 8.1.1 Test Standard  
FCC Part 15.247 (b)
- 8.1.2 Test Limit

FCC Part 15 Subpart C(15.247)/RSS-210		
Test Item	Limit	Frequency Range(MHz)
Peak Output Power	1 Watt or 30 dBm	2400~2483.5

### 8.2 Test Setup

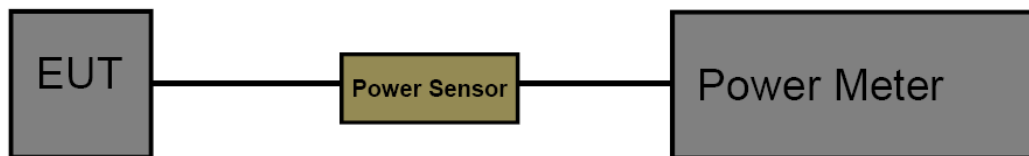

### 8.3 Test Procedure

The measurement is according to section 9.1.2 of KDB 558074 D01 DTS Meas Guidance v03r05.

The EUT was connected to RF power meter via a broadband power sensor as show the block above. The power sensor video bandwidth is greater than or equal to the DTS bandwidth of the equipment.

### 8.4 EUT Operating Condition

The EUT was set to continuously transmitting in the max power during the test.

8.5 Test Data

<b>EUT:</b>	Action camera	<b>Model Name :</b>	9028
<b>Temperature:</b>	25 °C	<b>Relative Humidity:</b>	55%
<b>Test Voltage:</b>	DC 3.7V		
Mode	Channel frequency (MHz)	Test Result (dBm)	Limit (dBm)
802.11b	2412	9.27	30
	2437	9.25	
	2462	9.19	
802.11g	2412	9.18	
	2437	9.14	
	2462	9.09	
802.11n (HT20)	2412	9.04	
	2437	9.08	
	2462	9.01	
802.11n (HT40)	2422	8.98	
	2437	9.00	
	2452	9.06	
<b>Result: PASS</b>			

Duty Cycle		
Mode	Channel frequency (MHz)	Test Result
802.11b	2412	>98%
	2437	
	2462	
802.11g	2412	
	2437	
	2462	
802.11n (HT20)	2412	
	2437	
	2462	
802.11n (HT40)	2422	
	2437	
	2452	
Please see below plots		

802.11 B Mode 2412 MHz

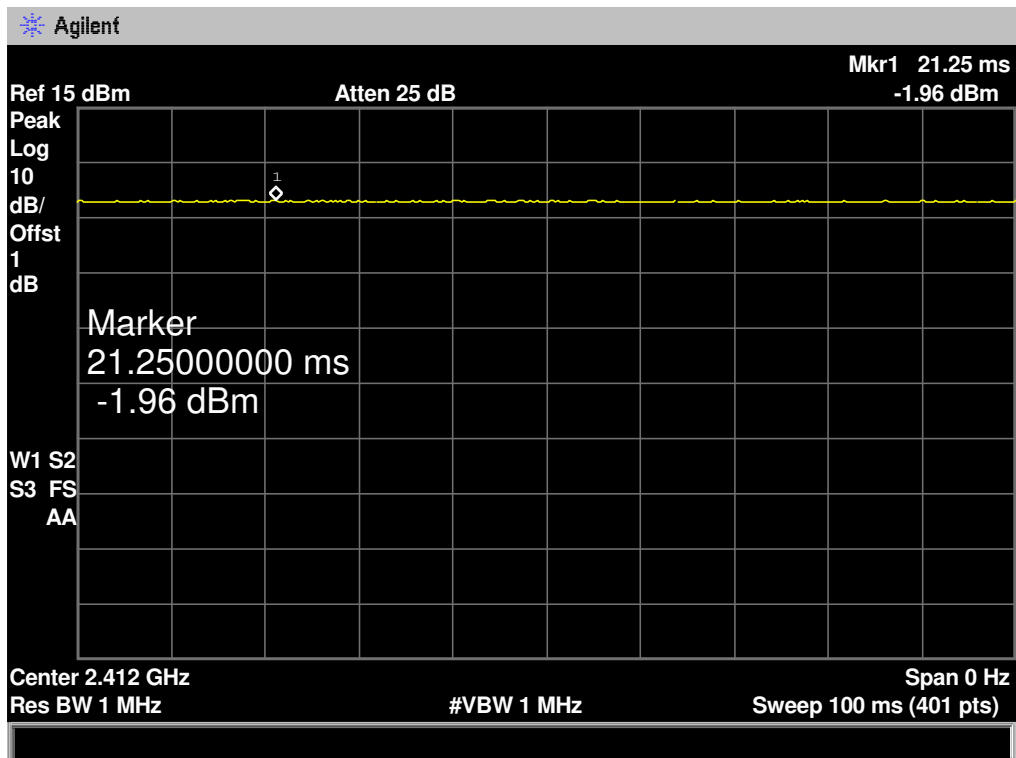

802.11 G Mode 2412 MHz

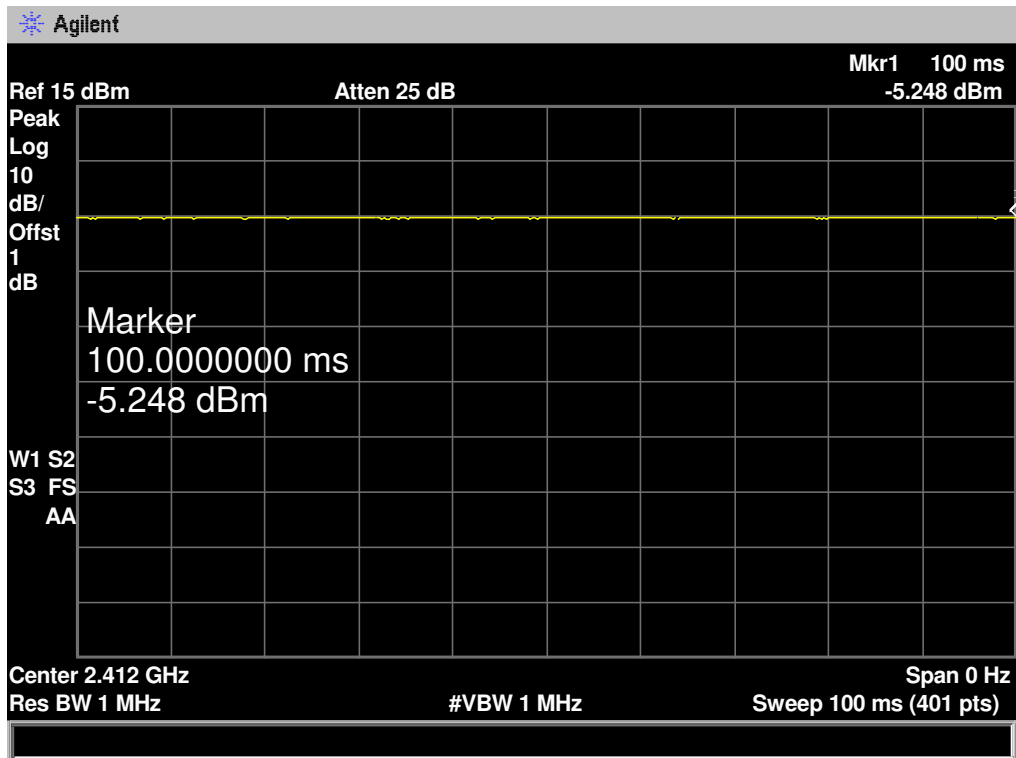

802.11 N(HT20) Mode 2412 MHz

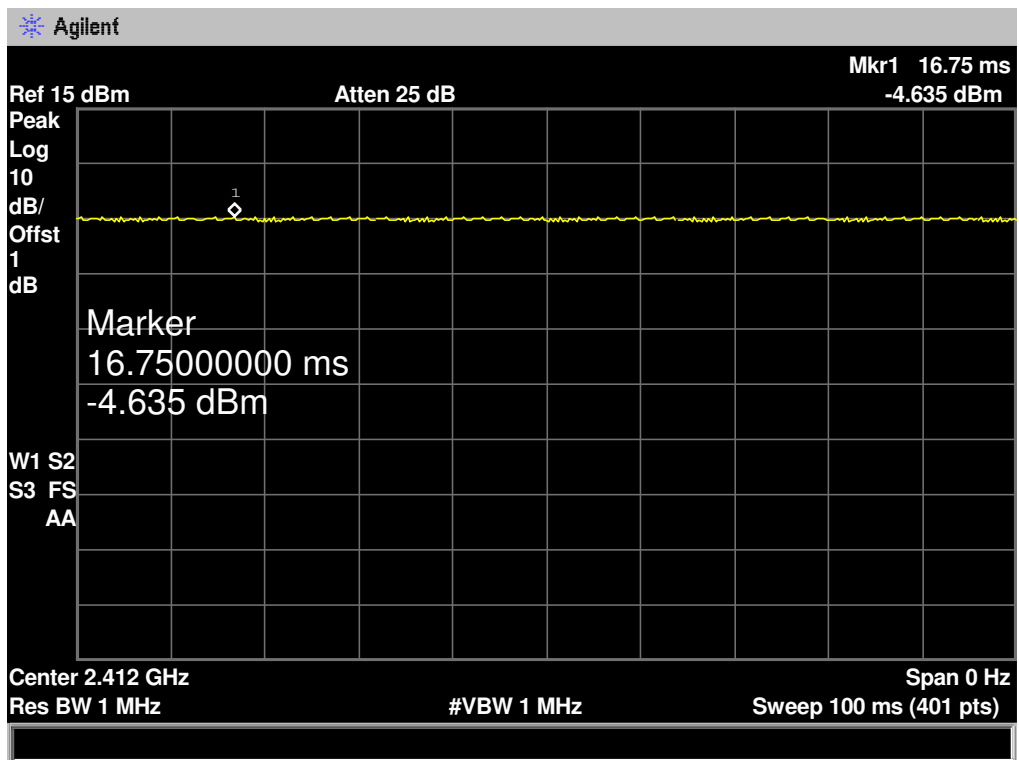

802.11 N(HT40) Mode 2422 MHz

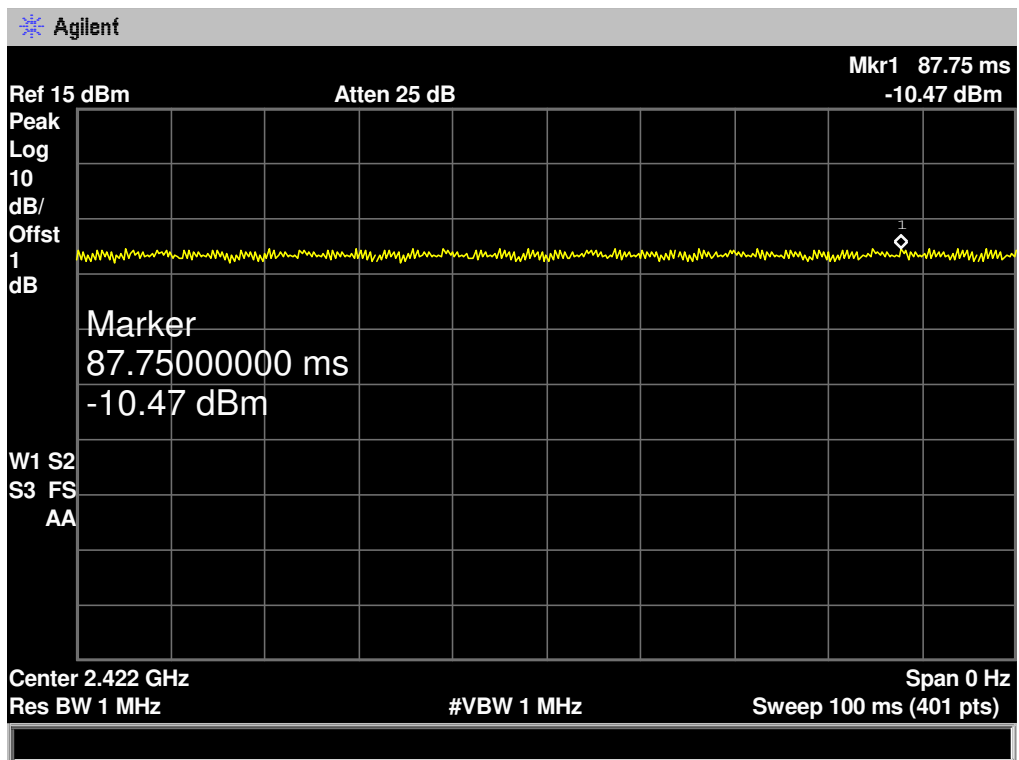

## 9. Power Spectral Density Test

### 9.1 Test Standard and Limit

- 9.1.1 Test Standard  
FCC Part 15.247 (e)
- 9.1.2 Test Limit

FCC Part 15 Subpart C(15.247)		
Test Item	Limit	Frequency Range(MHz)
Power Spectral Density	8dBm(in any 3 kHz)	2400~2483.5

### 9.2 Test Setup

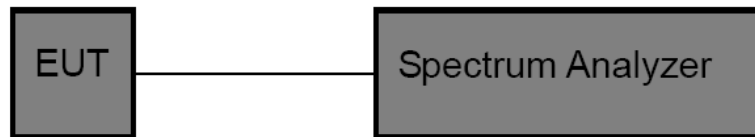

### 9.3 Test Procedure

The EUT was directly connected to the Spectrum Analyzer and antenna output port as show in the block diagram above. The measurement according to section 10.2 of KDB 558074 D01 DTS Meas Guidance v03r05.

- (1) The EUT was directly connected to the spectrum analyzer and antenna output port as show in the block diagram above.
- (2) Set analyser center frequency to DTS channel center frequency.
- (3) Set the span to 1.5 times the DTS bandwidth.
- (4) Set the RBW to: 3 kHz
- (5) Set the VBW to: 10 kHz
- (6) Detector: peak
- (7) Sweep time: auto
- (8) Allow trace to fully stabilize. Then use the peak marker function to determine the maximum amplitude level.

### 9.4 EUT Operating Condition

The EUT was set to continuously transmitting in each mode and low, middle and high channel for the test.

9.5 Test Data

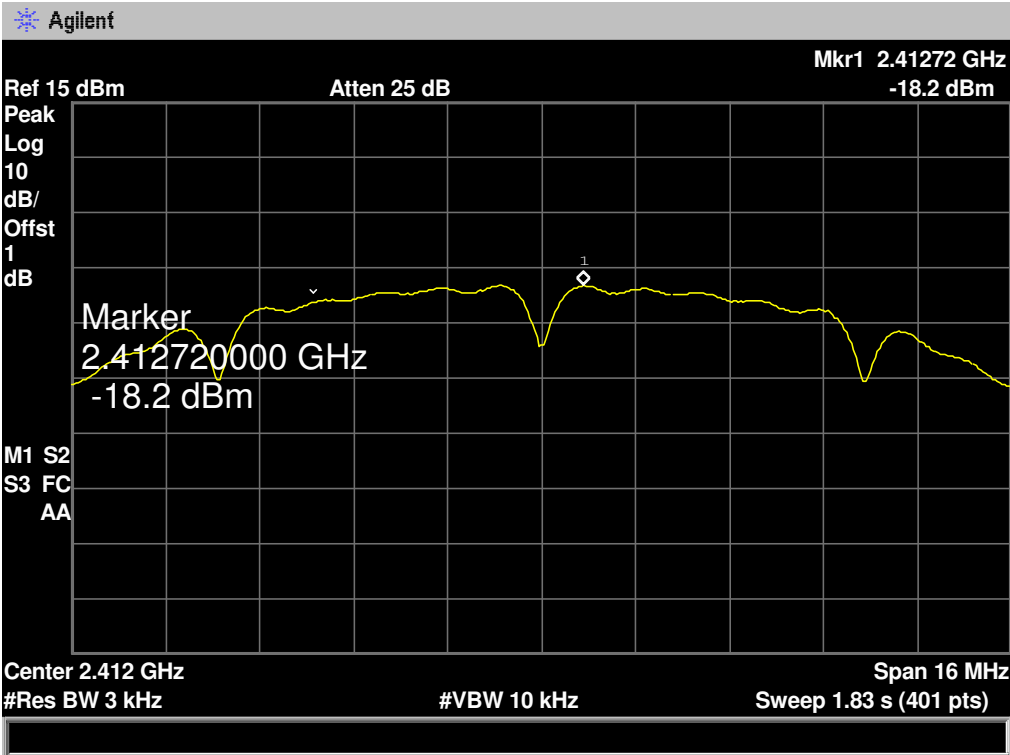
<b>EUT:</b>	Action camera	<b>Model:</b>	9028
<b>Temperature:</b>	25 °C	<b>Relative Humidity:</b>	55%
<b>Test Voltage:</b>	DC 3.7V		
<b>Test Mode:</b>	TX 802.11B Mode		
<b>Channel Frequency (MHz)</b>	<b>Power Density (3 kHz/dBm)</b>	<b>Limit (dBm)</b>	
2412	-18.20	<b>8</b>	
2437	-19.00		
2462	-18.05		
<b>802.11B Mode</b>			
<b>2412 MHz</b>			
			

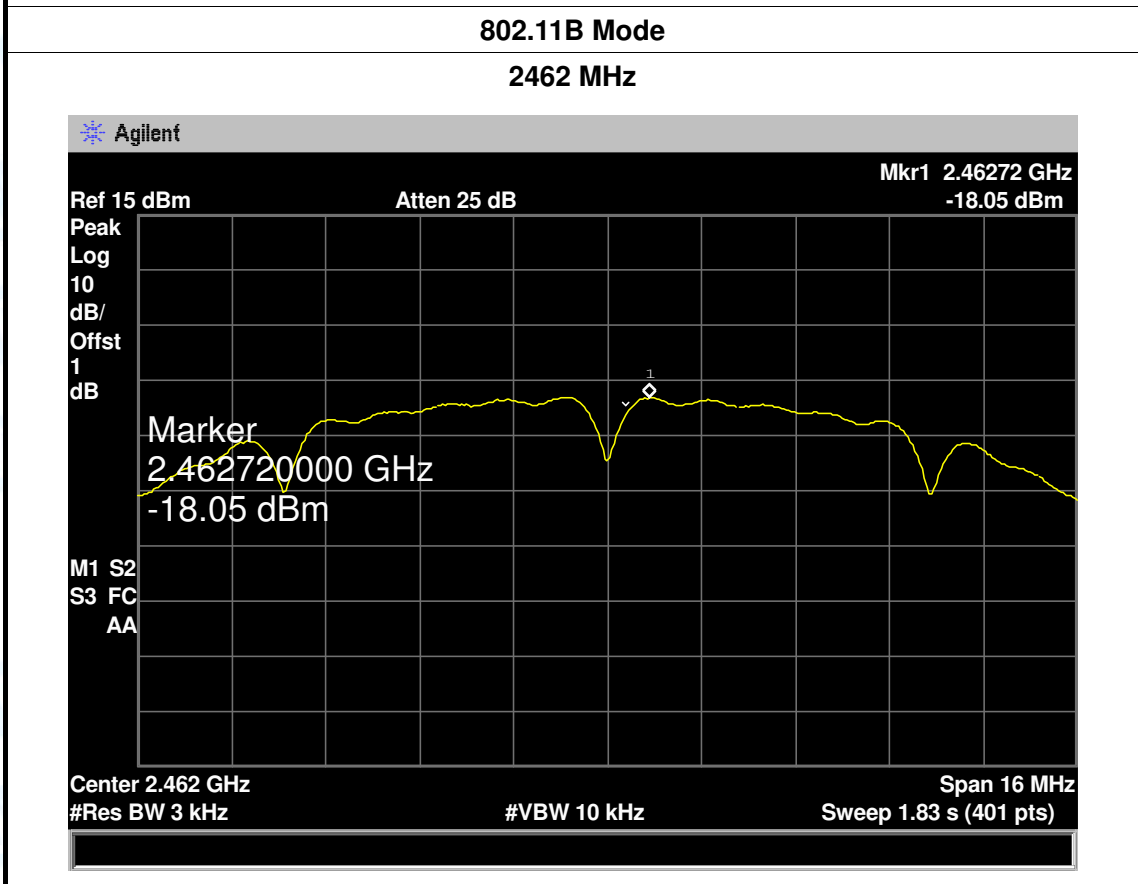
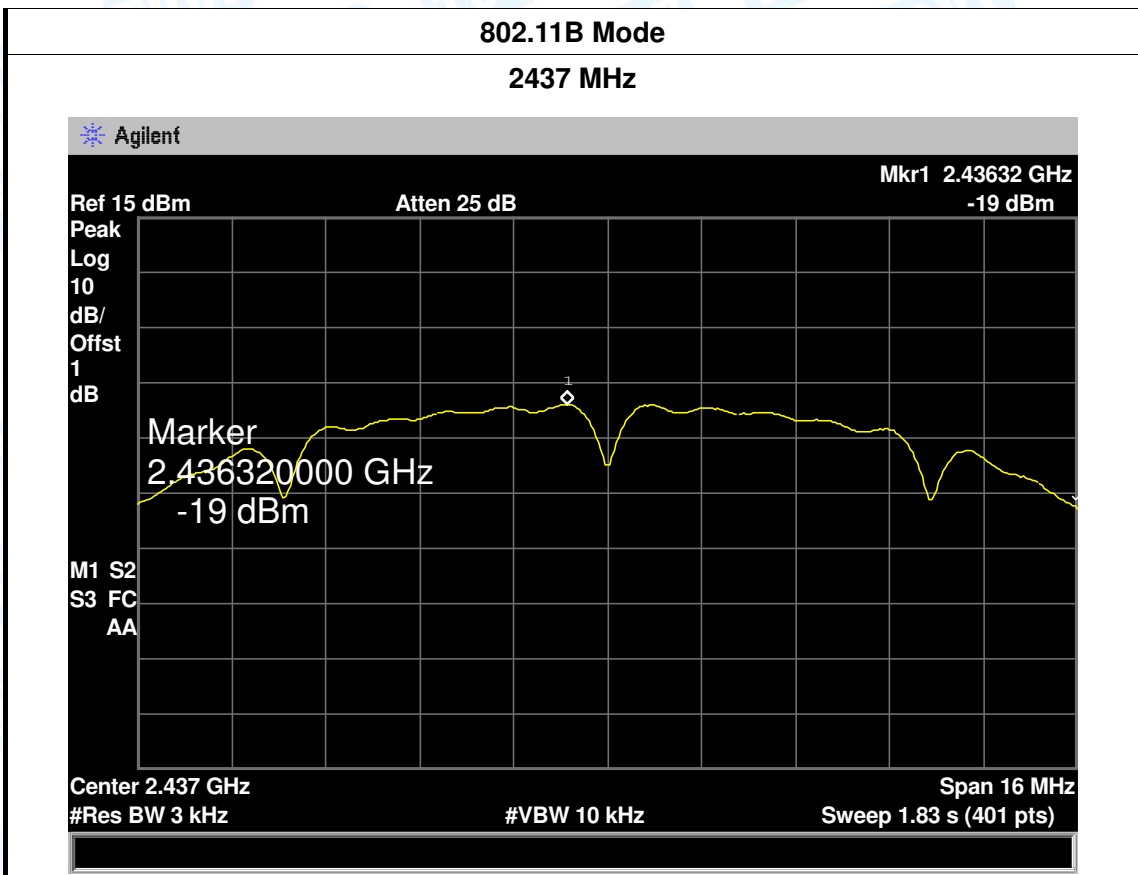

<b>EUT:</b>	Action camera	<b>Model:</b>	9028
<b>Temperature:</b>	25 °C	<b>Temperature:</b>	25 °C
<b>Test Voltage:</b>	DC 3.7V		
<b>Test Mode:</b>	TX 802.11G Mode		
<b>Channel Frequency (MHz)</b>	<b>Power Density (3 kHz/dBm)</b>	<b>Limit (dBm)</b>	
2412	-20.52	<b>8</b>	
2437	-20.46		
2462	-20.91		
<b>802.11G Mode</b>			
<b>2412 MHz</b>			

The screenshot shows an Agilent spectrum analyzer interface. The main display is a grid with a yellow signal trace. A marker is placed on the trace at 2.408880000 GHz, with a power density of -20.52 dBm. The reference level is 15 dBm and the attenuation is 25 dB. The center frequency is 2.412 GHz, the resolution bandwidth is 3 kHz, and the span is 24 MHz. The sweep time is 2.745 s with 401 points.

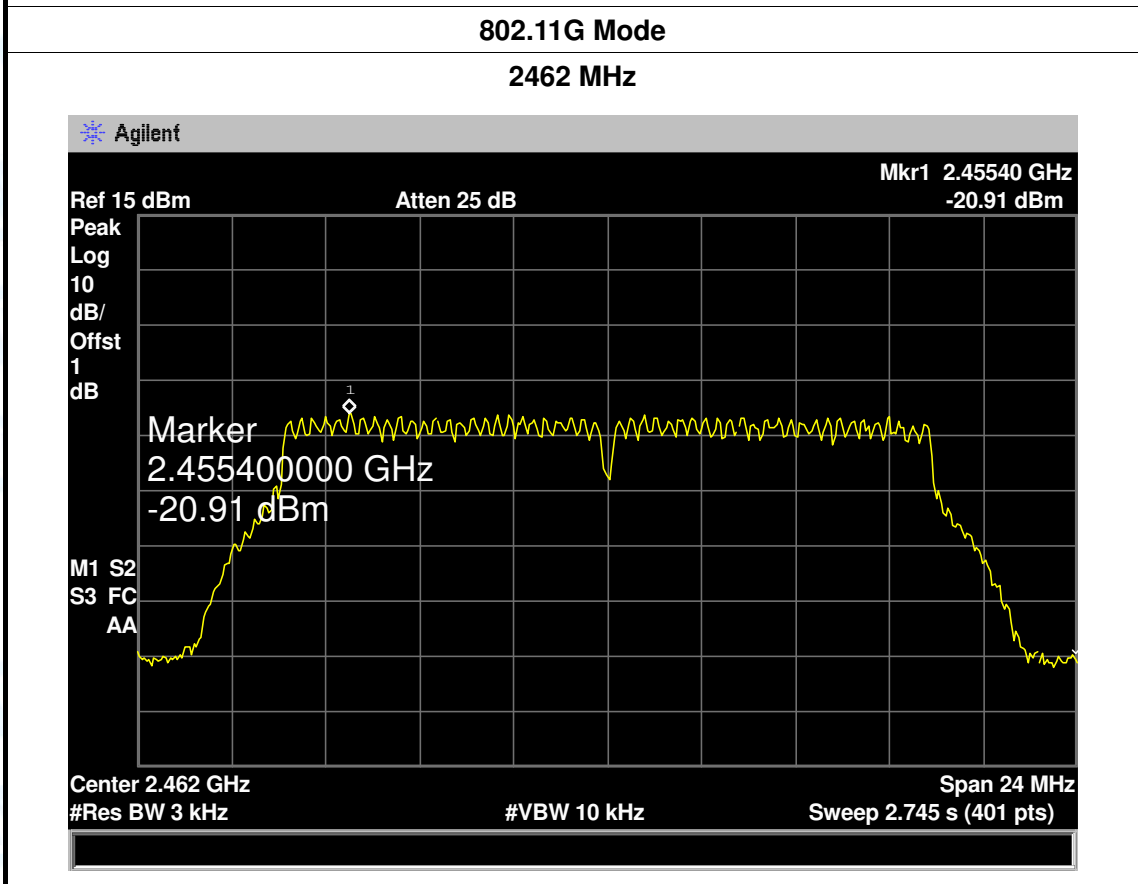
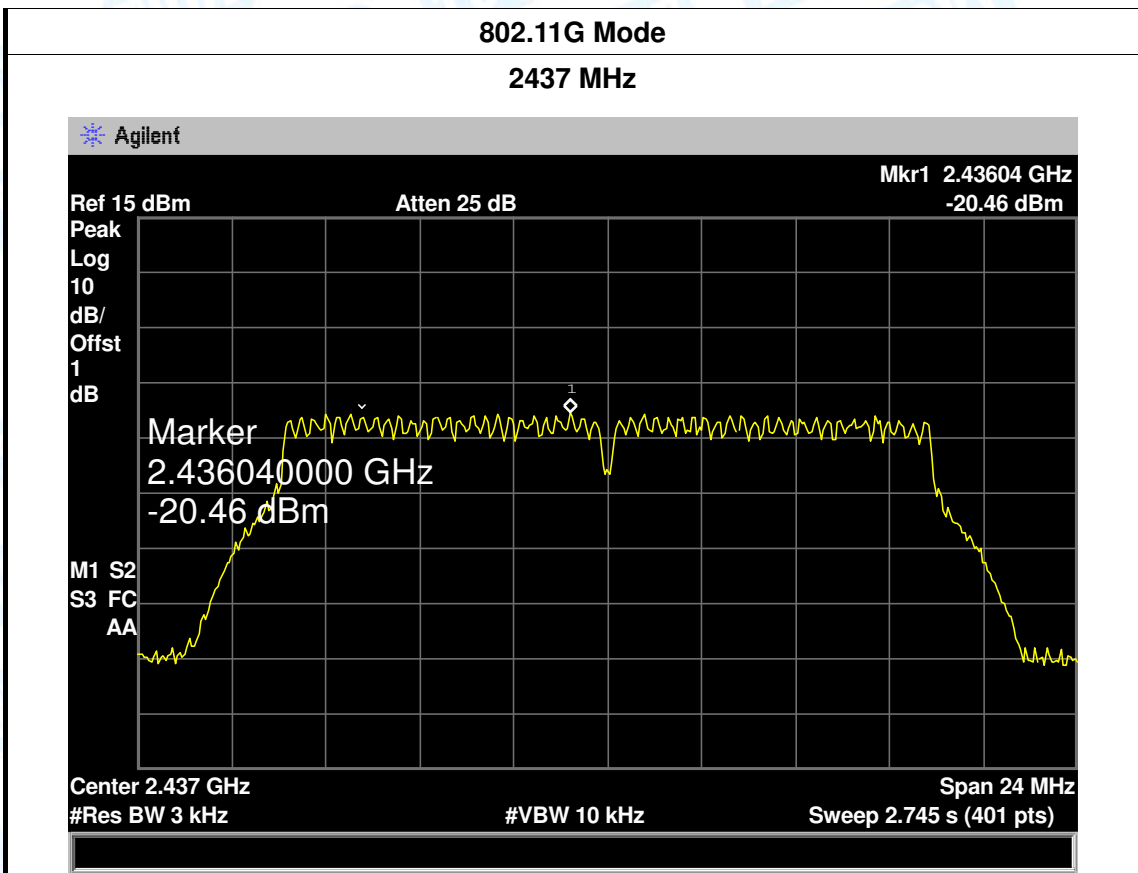

<b>EUT:</b>	Action camera	<b>Model:</b>	9028
<b>Temperature:</b>	25 °C	<b>Temperature:</b>	25 °C
<b>Test Voltage:</b>	DC 3.7V		
<b>Test Mode:</b>	TX 802.11N(HT20) Mode		
<b>Channel Frequency (MHz)</b>	<b>Power Density (3 kHz/dBm)</b>	<b>Limit (dBm)</b>	
2412	-21.99	<b>8</b>	
2437	-22.01		
2462	-22.52		

**802.11N(HT20) Mode**

**2412 MHz**

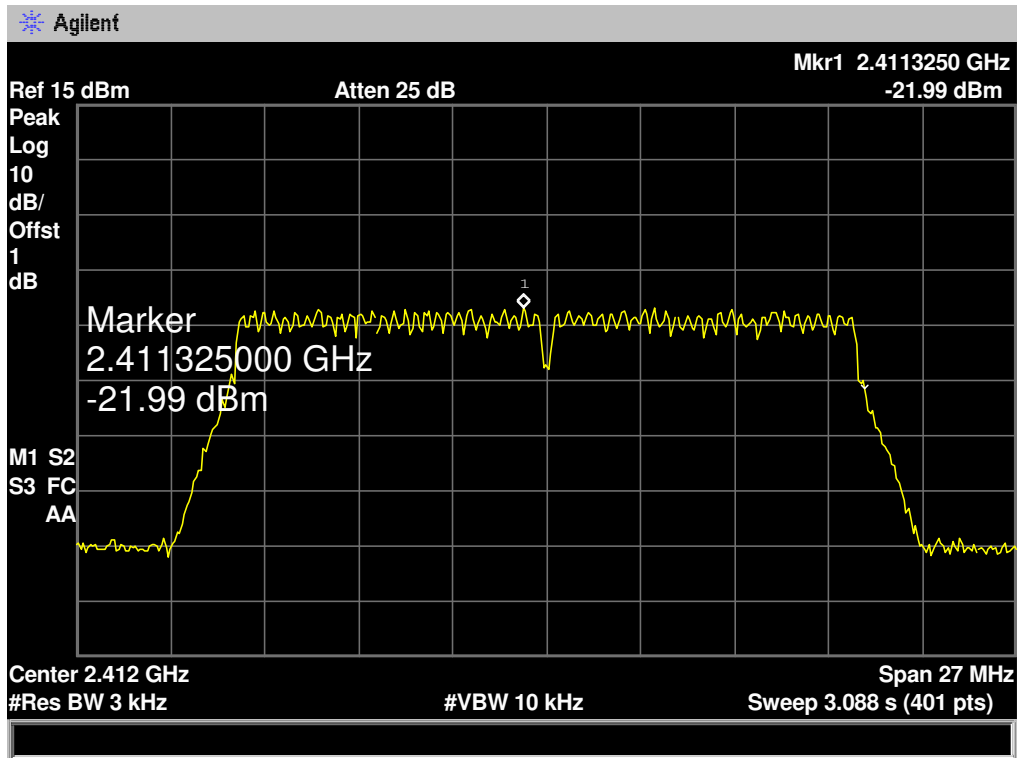

802.11N(HT20) Mode

2437 MHz

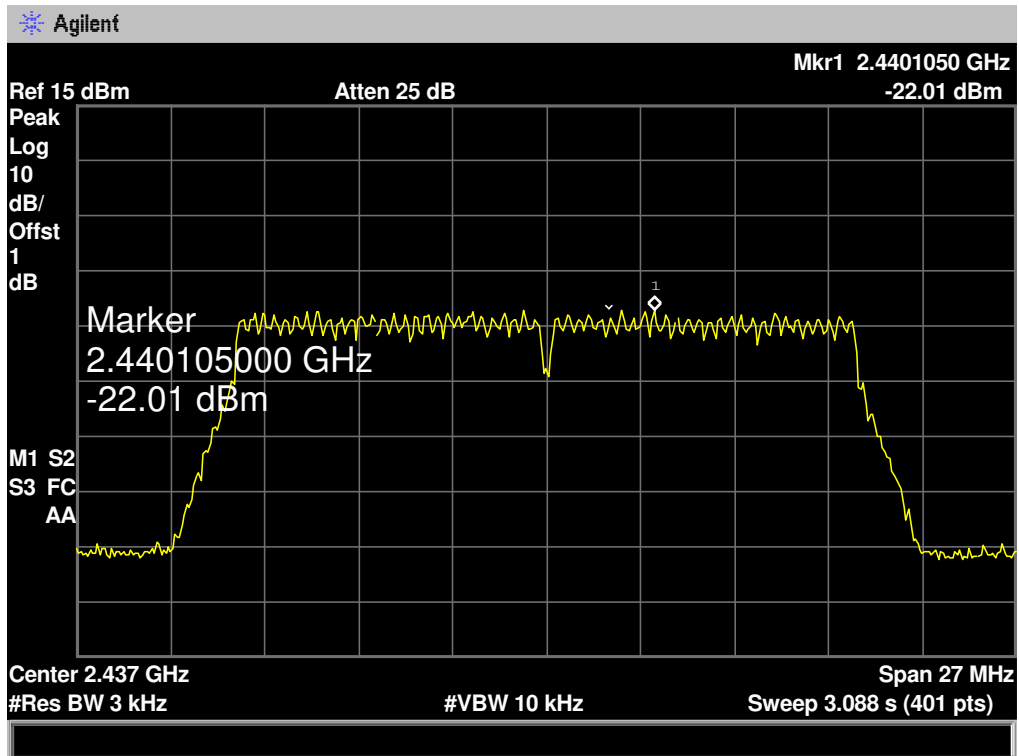

802.11N(HT20) Mode

2462 MHz

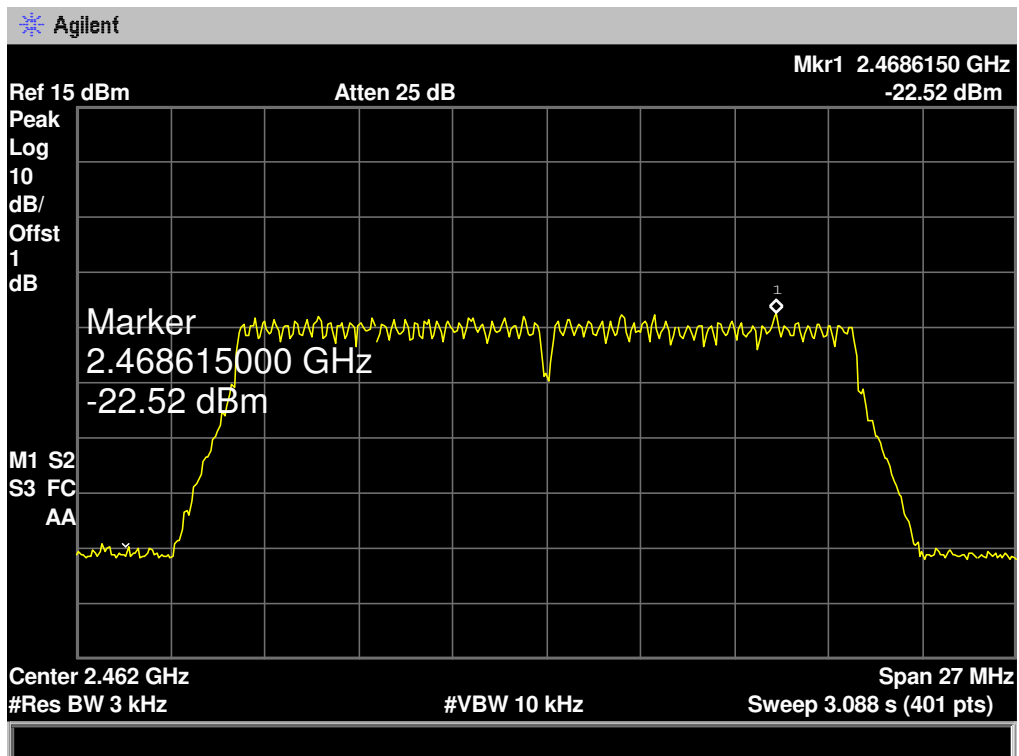

<b>EUT:</b>	Action camera	<b>Model:</b>	9028
<b>Temperature:</b>	25 °C	<b>Temperature:</b>	25 °C
<b>Test Voltage:</b>	DC 3.7V		
<b>Test Mode:</b>	TX 802.11N(HT40) Mode		
<b>Channel Frequency (MHz)</b>	<b>Power Density (3 kHz/dBm)</b>	<b>Limit (dBm)</b>	
2422	-25.32	<b>8</b>	
2437	-24.76		
2452	-25.83		

**802.11N(HT40) Mode**

**2422 MHz**

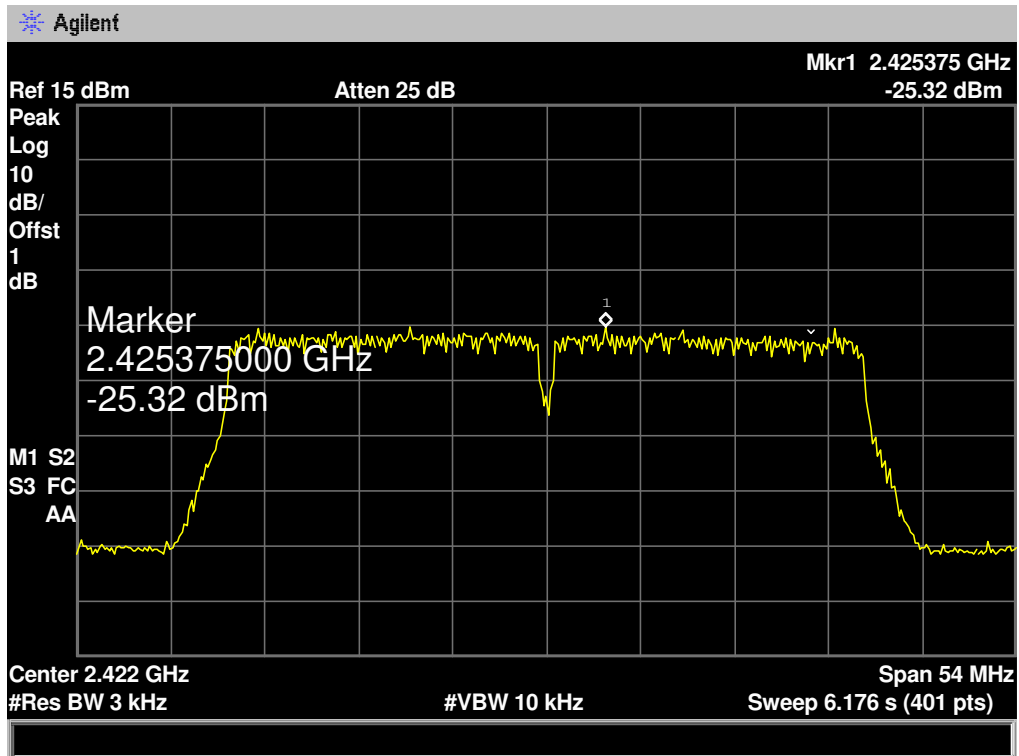

802.11N(HT40) Mode

2437 MHz

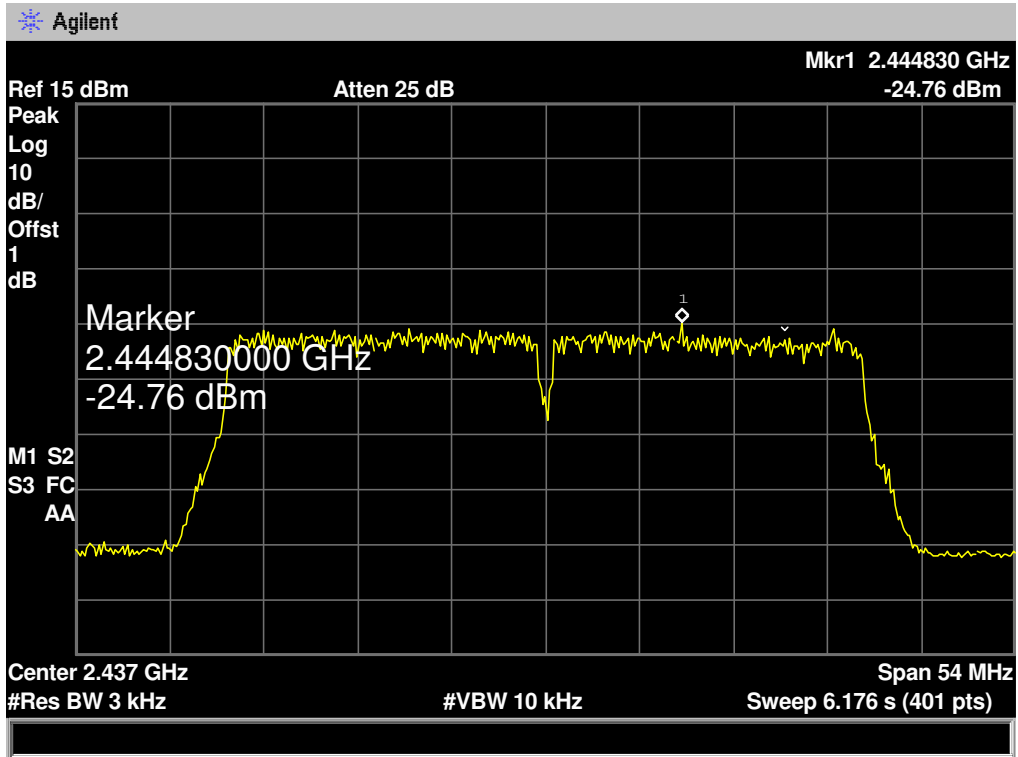

802.11N(HT40) Mode

2452 MHz

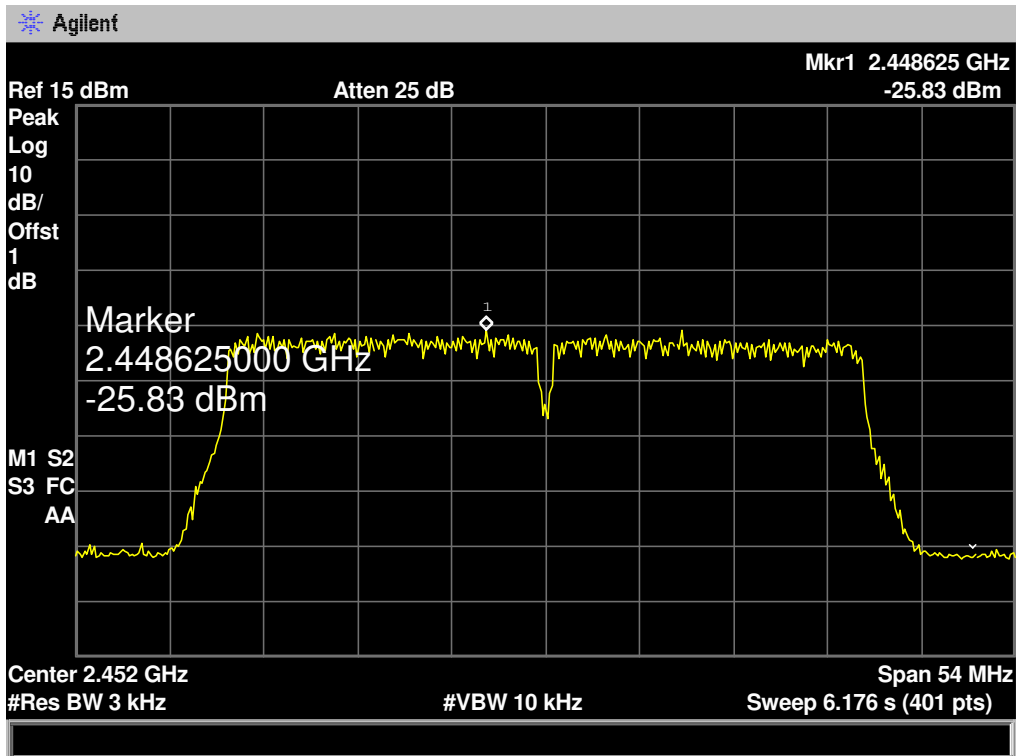

## 10. Antenna Requirement

### 10.1 Standard Requirement

#### 10.1.1 Standard

FCC Part 15.203

#### 10.1.2 Requirement

An intentional radiator shall be designed to ensure that no antenna other than that furnished by the responsible party shall be used with the device. The use of a permanently attached antenna or of an antenna that uses a unique coupling to the intentional radiator shall be considered sufficient to comply with the provisions of this Section. The manufacturer may design the unit so that a broken antenna can be replaced by the user, but the use of a standard antenna jack or electrical connector is prohibited.

### 10.2 Antenna Connected Construction

The directional gains of the antenna used for transmitting is 0.44 dBi, and the antenna de-signed with permanent attachment and no consideration of replacement. Please see the EUT photo for details.

#### Result

The EUT antenna is a PCB Antenna. It complies with the standard requirement.

Antenna Type
<input checked="" type="checkbox"/> Permanent attached antenna
<input type="checkbox"/> Unique connector antenna
<input type="checkbox"/> Professional installation antenna

-----End of report-----