

TEST REPORT

Product Name : Car Head Up Display
Brand Name : N/A
Model : M2
Series Model : M2S, G20, X1, X3, G19, G5, M23, M22, G3, G18,G9, P25, M7, M8, M11
Applicant : **Shenzhen Wins Novelty Co.,Ltd**
Address : 2F, BLDG 30, Chen tian Industrial Area, Xi Xiang Street, Bao an District, Shenzhen, China
Manufacturer : **Shenzhen Wins Novelty Co.,Ltd**
Address : 2F, BLDG 30, Chen tian Industrial Area, Xi Xiang Street, Bao an District, Shenzhen, China
Standard(s) : FCC CFR Title 47 Part 15 Subpart B
FCC ID : 2BLYN-M2
Date of Receipt : Oct. 15, 2024
Date of Test : Oct. 15, 2024 ~ Oct. 24, 2024
Issued Date : Oct. 25, 2024

Issued By: **Guangdong Asia Hongke Test Technology Limited**
B1/F, Building 11, Junfeng Industrial Park, Chongqing Road, Heping Community, Fuhai Street,
Bao'an District, Shenzhen, Guangdong, China
Tel.: +86 0755-230967639 Fax.: +86 0755-230967639

Reviewed by: Leon Yi
Leon.yi

Approved by: Sean She
Sean She



Note: This device has been tested and found to comply with the standard(s) listed, this test report merely corresponds to the test sample. It is not permitted to copy extracts of these test result without the written permission of the test laboratory. This report shall not be reproduced except in full, without the written approval of Guangdong Asia Hongke Test Technology Limited. If there is a need to alter or revise this document, the right belongs to Guangdong Asia Hongke Test Technology Limited, and it should give a prior written notice of the revision document. This test report must not be used by the client to claim product endorsement.

Report Revise Record

Report Version	Issued Date	Notes
M1	Oct. 25, 2024	Initial Release

Contents

1	TEST SUMMARY.....	4
1.1	TEST STANDARDS	4
1.2	TEST SUMMARY	4
1.3	TEST FACILITY	5
1.4	MEASUREMENT UNCERTAINTY	5
2	GENGENERAL INFORMATION	6
2.1	ENVIRONMENTAL CONDITIONS	6
2.2	GENERAL DESCRIPTION OF EUT	6
2.3	DESCRIPTION OF TEST MODES	6
2.4	SPECIAL ACCESSORIES	7
2.5	EQUIPMENT LIST FOR THE TEST	7
3	TEST CONDITIONS AND RESULTS	8
3.1	CONDUCTED EMISSION	8
3.2	RADIATED EMISSION	11
4	TEST SETUP PHOTOGRAPHS OF EUT	15
5	EXTERNAL PHOTOGRAPHS OF EUT	16
6	INTERNAL PHOTOGRAPHS OF EUT	16

1 TEST SUMMARY

1.1 Test Standards

The tests were performed according to following standards:

[47 CFR FCC Part 15 Subpart B](#) - Unintentional Radiators

[ANSI C63.4: 2014](#) – American National Standard for Methods of Measurement of Radio-Noise Emissions from Low-Voltage Electrical and Electronic Equipment in the Range of 9 kHz to 40GHz

1.2 Test Summary

Test Item	Section in CFR 47	Test Result
AC Power Line Conducted Emission	FCC Part 15 B (Section15.107)	PASS
Electric Field Radiated Emissions	FCC Part 15 B (Section15.109)	PASS

1.3 Test Facility

Test Laboratory:

Guangdong Asia Hongke Test Technology Limited

B1/F, Building 11, Junfeng Industrial Park, Chongqing Road, Heping Community, Fuhai Street, Bao'an District, Shenzhen, Guangdong, China

The test facility is recognized, certified or accredited by the following organizations:

FCC-Registration No.: 251906 Designation Number: CN1376

Guangdong Asia Hongke Test Technology Limited has been registered and fully described in a report filed with the (FCC) Federal Communications Commission. The acceptance letter from the FCC is maintained in our files.

IC —Registration No.: 31737 CAB identifier: CN0165

The 3m Semi-anechoic chamber of Guangdong Asia Hongke Test Technology Limited has been registered by Certification and Engineering Bureau of Industry Canada for radio equipment testing with Registration No.: 31737

A2LA-Lab Cert. No.: 7133.01

Guangdong Asia Hongke Test Technology Limited has been accredited by A2LA for technical competence in the field of electrical testing, and proved to be in compliance with ISO/IEC 17025: 2017 General Requirements for the Competence of Testing and Calibration Laboratories and any additional program requirements in the identified field of testing.

1.4 Measurement uncertainty

The data and results referenced in this document are true and accurate. The reader is cautioned that there may be errors within the calibration limits of the equipment and facilities. The measurement uncertainty was calculated for all measurements listed in this test report according to CISPR 16 - 4 “Specification for radio disturbance and immunity measuring apparatus and methods – Part 4: Uncertainty in EMC Measurements” and is documented in the Guangdong Asia Hongke Test Technology Limited’s quality system according to DIN EN ISO/IEC 17025. Furthermore, component and process variability of devices similar to that tested may result in additional deviation. The manufacturer has the sole responsibility of continued compliance of the device.

Hereafter the best measurement capability for Asia Hongke laboratory is reported:

Test	Measurement Uncertainty	Notes
Power Line Conducted Emission	150KHz~30MHz ±1.20 dB	(1)
Radiated Emission	9KHz~30Hz ±3.10dB	(1)
Radiated Emission	9KHz~1GHz ±3.75dB	(1)
Radiated Emission	1GHz~18GHz ±3.88 dB	(1)
Radiated Emission	18GHz~40GHz ±3.88dB	(1)
RF power, conducted	30MHz~6GHz ±0.16dB	(1)
RF power density, conducted	±0.24dB	(1)
Spurious emissions, conducted	±0.21dB	(1)
Temperature	±1°C	(1)
Humidity	±3%	(1)
DC and low frequency voltages	±1.5%	(1)
Time	±2%	(1)
Duty cycle	±2%	(1)

The report uncertainty of measurement $y \pm U$, where expanded uncertainty U is based on a standard uncertainty Multiplied by a coverage factor of $k=2$, providing a level of confidence of approximately 95%

2 GENGGENERAL INFORMATION

2.1 Environmental conditions

During the measurement the environmental conditions were within the listed ranges:

Normal Temperature:	25°C
Relative Humidity:	55 %
Air Pressure:	101 kPa

2.2 General Description of EUT

Product Name:	Car Head Up Display
Model/Type reference:	M2
Serial Model:	M2S, G20, X1, X3, G19, G5, M23, M22, G3, G18,G9, P25, M7, M8, M11
Power Supply:	DC 3.7V
Adapter information:	N/A
Hardware Version:	N/A
Software Version:	N/A
I/O ports:	/

2.3 Description of Test Modes

The device, according to the function of the EUT, select the following operating modes for testing.

Test Modes:	
Mode 1	Working mode
Mode 2	Idle

Note:

1. Pre-testing on all test modes, only the worst case mode was recorded in this report.
2. After the pre-testing, the following test modes were found to be the worst mode for the corresponding test items and recorded in the report

Test item	Test mode (Worse case operation mode)
EMI	Test mode 1

2.4 Special Accessories

Follow auxiliary equipment(s) test with EUT that provided by the manufacturer or laboratory is listed as follow:

Description	Manufacturer	Model	Serial No.	Provided by	Other
Adapter	HNT	HNT-QC530	/	Test lab	/
/	/	/	/	/	/
/	/	/	/	/	/
/	/	/	/	/	/

2.5 Equipment List for the Test

<input checked="" type="checkbox"/> Radiation Emission Test Equipment (AiT 966 chamber)						
Item	Test Equipment	Manufacturer	Model No.	Serial No.	Last Cal.	Cal.Due
1	EMI Measuring Receiver	R&S	ESR	101160	2024.09.08	2025.09.07
2	Low Noise Pre Amplifier	Tsj	MLA-10K01-B01-27	1205323	2024.09.08	2025.09.07
3	TRILOG Super Broadband test Antenna	SCHWARZBECK	VULB9160	9160-3207	2024.09.08	2025.09.07
4	50Ω Coaxial Switch	Anritsu	MP59B	6200264416	2024.09.08	2025.09.07
5	Spectrum Analyzer	R&S	FSV40	101470	2024.09.08	2025.09.07
6	Low Noise Pre Amplifier	Tsj	MLA-0120-A02-34	2648A04738	2024.09.08	2025.09.07
7	Broadband Horn Antenna	Schwarzbeck	BBHA 9120D	452	2024.09.08	2025.09.07
8	Filter	MICRO-TRONICS	BRM50702-02	16	2024.09.08	2025.09.07
9	Filter	MICRO-TRONICS	BRC50703-02	17	2024.09.08	2025.09.07
10	Filter	MICRO-TRONICS	BRC50705-02	18	2024.09.08	2025.09.07

<input checked="" type="checkbox"/> Conducted Emission Test Equipment (AiT shielded room)						
Item	Test Equipment	Manufacturer	Model No.	Serial No.	Last Cal.	Cal.Due
1	EMI Test Receiver	R&S	ESCI	100124	2024.09.08	2025.09.07
2	LISN	Kyoritsu	KNW-242	8-837-4	2024.09.08	2025.09.07
3	LISN	R&S	ESH3-Z2	0357.8810.54101161-S2	2024.09.08	2025.09.07
4	50Ω Coaxial Switch	Anritsu	MP59B	6200264417	2024.09.08	2025.09.07
5	Low Noise Pre Amplifier	Tsj	MLA-0120-A02-34	2648A04738	2024-09-08	2025-09-07
6	Broadband Horn Antenna	SCHWARZBECK	BBHA 9120D	452	2024-08-29	2025-08-28

3 TEST CONDITIONS AND RESULTS

3.1 Conducted Emission

LIMIT

For unintentional device, according to § 15.107(a) Line Conducted Emission Limits is as following :

FREQUENCY (MHz)	☐ Class A (dBuV)		☒ Class B (dBuV)	
	Quasi-peak	Average	Quasi-peak	Average
0.15 -0.5	79.00	66.00	66 - 56 *	56 - 46 *
0.50 -5.0	73.00	60.00	56.00	46.00
5.0 -30.0	73.00	60.00	60.00	50.00

TEST PROCEDURE

- a) The equipment was set up as per the test configuration to simulate typical actual usage per the user’s manual. The EUT is a tabletop system; a wooden table with a height of 0.8 meters is used and is placed on the ground plane as per ANSI C63.4-2014.
- b) Support equipment, if needed, was placed as per ANSI C63.4-2014.
- c) All I/O cables were positioned to simulate typical actual usage as per ANSI C63.4-2014.
- d) The EUT received AC120V/60Hz power through a Line Impedance Stabilization Network (LISN) which supplied power source and was grounded to the ground plane.
- e) All support equipments received AC power from a second LISN, if any.
- f) The EUT test program was started. Emissions were measured on each current carrying line of the EUT using a spectrum Analyzer / Receiver connected to the LISN powering the EUT. The LISN has two monitoring points: Line 1 (Hot Side) and Line 2 (Neutral Side). Two scans were taken: one with Line 1 connected to Analyzer / Receiver and Line 2 connected to a 50 ohm load; the second scan had Line 1 connected to a 50 ohm load and Line 2 connected to the Analyzer / Receiver.
- g) Analyzer / Receiver scanned from 150 KHz to 30MHz for emissions in each of the test modes.
- h) During the above scans, the emissions were maximized by cable manipulation.

TEST SETUP

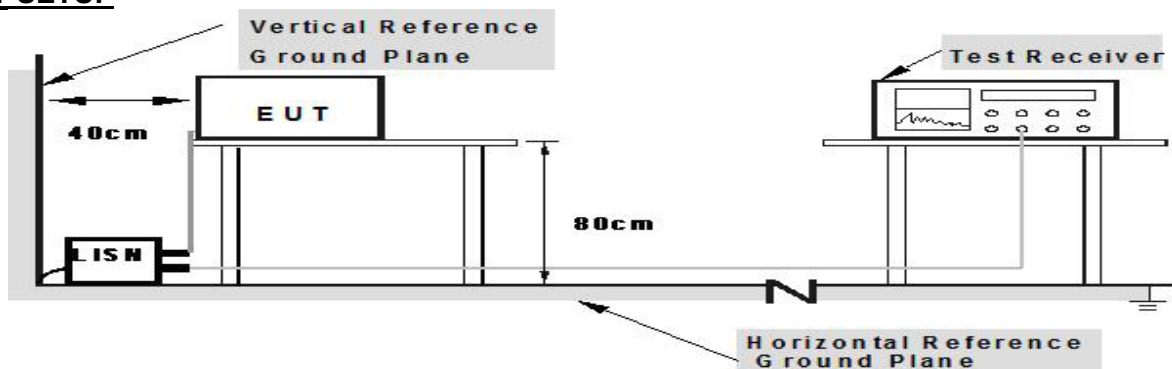

**Note: 1. Support units were connected to second LISN.
 2. Both of LISNs (AMN) are 80 cm from EUT and at least 80 from other units and other metal planes**

TEST RESULTS

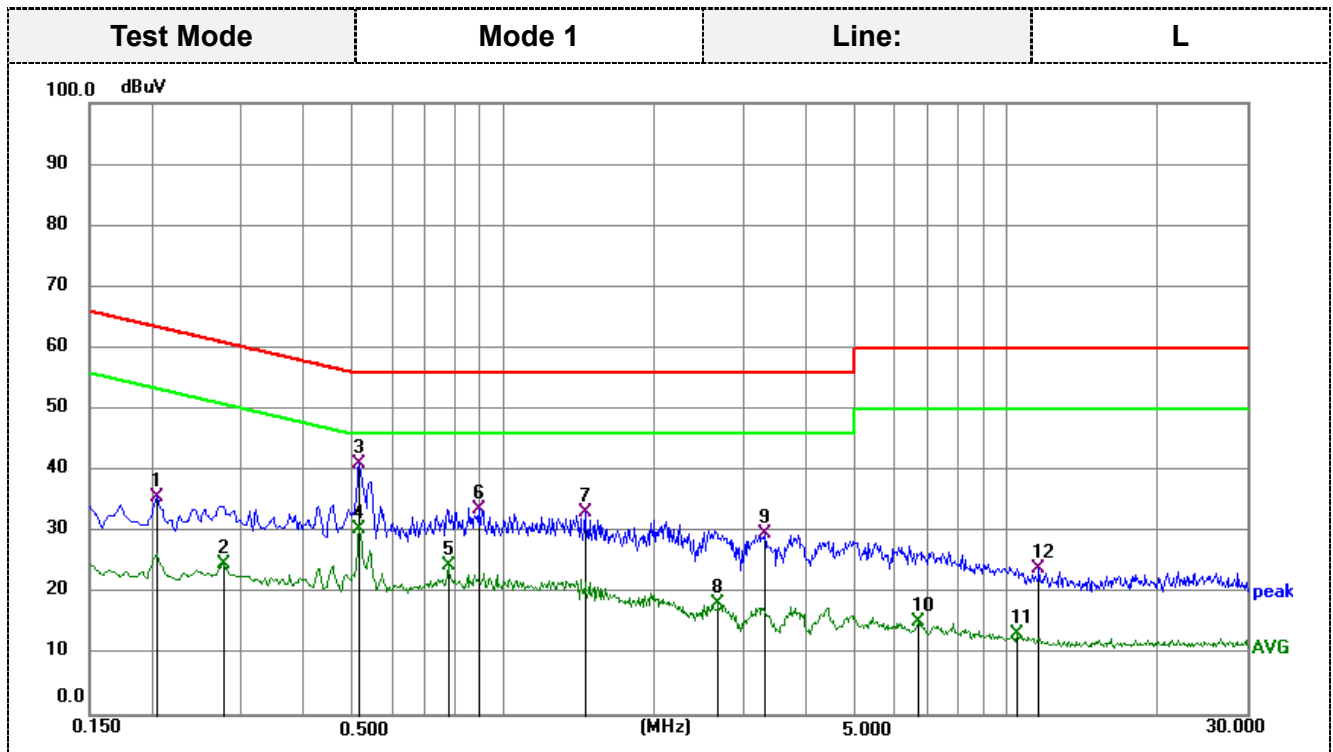

Remark: Correct Factor = Insertion loss of LISN + Cable loss + Insertion loss of Pulse Limiter;
 Measurement Result = Reading Level + Correct Factor;
 Margin = Measurement Result - Limit

No.	Frequency (MHz)	Reading (dBuV)	Correct (dB)	Result (dBuV)	Limit (dBuV)	Margin (dB)	Remark
1	0.2040	25.02	10.70	35.72	63.45	-27.73	QP
2	0.2760	14.07	10.70	24.77	50.94	-26.17	AVG
3	0.5144	30.41	10.69	41.10	56.00	-14.90	QP
4	0.5144	19.61	10.69	30.30	46.00	-15.70	AVG
5	0.7754	13.81	10.67	24.48	46.00	-21.52	AVG
6	0.8924	23.03	10.65	33.68	56.00	-22.32	QP
7	1.4550	22.39	10.70	33.09	56.00	-22.91	QP
8	2.6700	7.34	10.80	18.14	46.00	-27.86	AVG
9	3.3044	18.66	10.89	29.55	56.00	-26.45	QP
10	6.6840	4.19	11.03	15.22	50.00	-34.78	AVG
11	10.4550	2.24	11.09	13.33	50.00	-36.67	AVG
12	11.5620	12.59	11.24	23.83	60.00	-36.17	QP

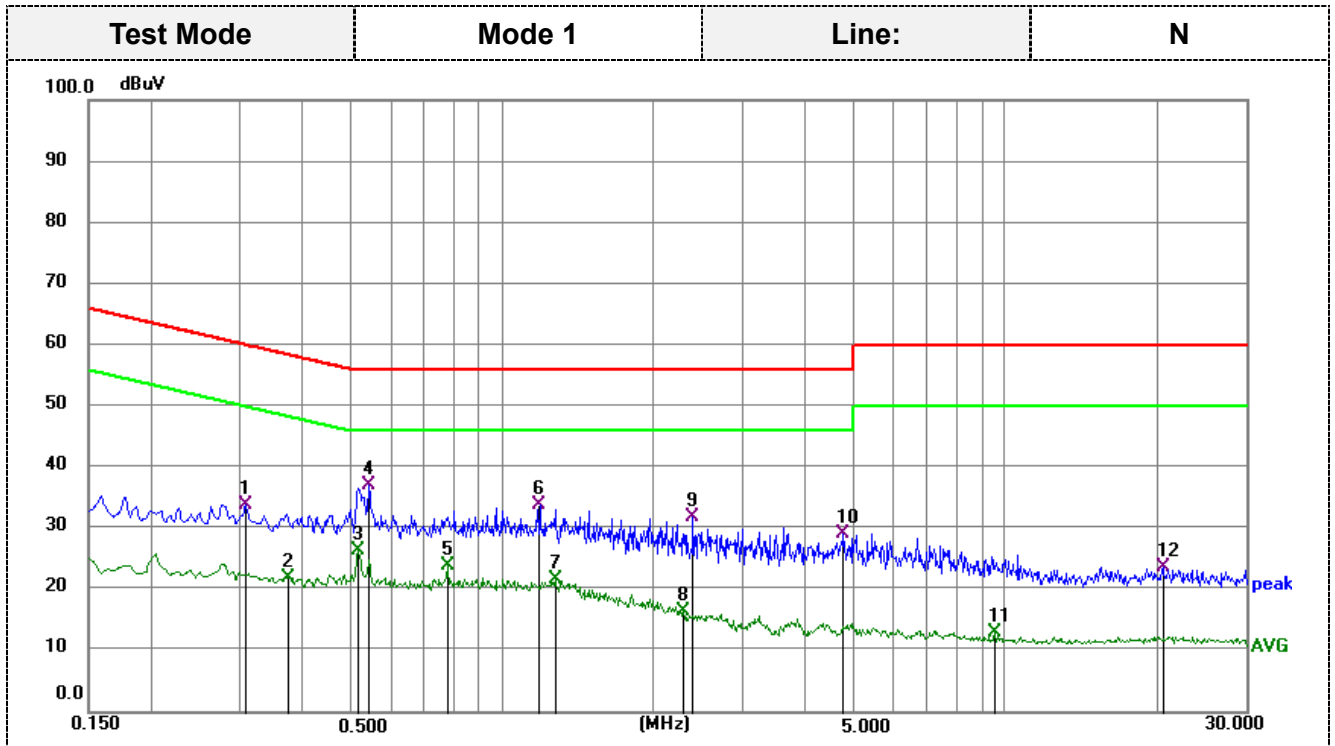

Remark: Correct Factor = Insertion loss of LISN + Cable loss + Insertion loss of Pulse Limiter;
 Measurement Result = Reading Level + Correct Factor;

Margin = Measurement Result- Limit

No.	Frequency (MHz)	Reading (dBuV)	Correct (dB)	Result (dBuV)	Limit (dBuV)	Margin (dB)	Remark
1	0.3075	23.21	10.69	33.90	60.04	-26.14	QP
2	0.3750	11.31	10.69	22.00	48.39	-26.39	AVG
3	0.5144	15.74	10.69	26.43	46.00	-19.57	AVG
4	0.5415	26.32	10.68	37.00	56.00	-19.00	QP
5	0.7755	13.36	10.66	24.02	46.00	-21.98	AVG
6	1.1849	23.32	10.66	33.98	56.00	-22.02	QP
7	1.2705	10.99	10.67	21.66	46.00	-24.34	AVG
8	2.2965	5.77	10.78	16.55	46.00	-29.45	AVG
9	2.3865	21.12	10.78	31.90	56.00	-24.10	QP
10	4.7490	18.13	11.01	29.14	56.00	-26.86	QP
11	9.5145	2.03	10.94	12.97	50.00	-37.03	AVG
12	20.5035	12.03	11.66	23.69	60.00	-36.31	QP

3.2 Radiated Emission

LIMITS

LIMITS OF RADIATED EMISSION MEASUREMENT (Below 1000MHz)

FREQUENCY (MHz)	<input type="checkbox"/> Class A (at 10m)	<input checked="" type="checkbox"/> Class B (at 3m)
	dBuV/m	
30 ~ 88	39.0	40.0
88 ~ 216	43.5	43.5
216 ~ 960	46.5	46.0
Above 960	49.5	54.0

LIMITS OF RADIATED EMISSION MEASUREMENT (Above 1000MHz)

FREQUENCY (MHz)	Class A (at 3m) dBuV/m		Class B (at 3m) dBuV/m	
	Peak	Avg	Peak	Avg
Above 1000	80	60	74	54

Notes:

- 1) The limit for radiated test was performed according to as following:
CISPR 22/ FCC PART 15B /ICES-003.
- 2) The tighter limit applies at the band edges.
- 3) Emission level (dBuV/m)=20log Emission level (uV/m).

TEST PROCEDURE

- a) The measuring distance of at 10 m shall be used for measurements at frequency up to 1GHz. For frequencies above 1GHz, any suitable measuring distance may be used.
- b) The EUT was placed on the top of a rotating table 0.8 meters above the ground at a 10 meter open area test site. The table was rotated 360 degrees to determine the position of the highest radiation.
- c) The height of the equipment or of the substitution antenna shall be 0.8 m; the height of the test antenna shall vary between 1 m to 4 m. Both horizontal and vertical polarizations of the antenna are set to make the measurement.
- d) The initial step in collecting conducted emission data is a spectrum analyzer peak detector mode pre-scanning the measurement frequency range. Significant peaks are then marked and then Quasi Peak detector mode re-measured, above 1G Average detector mode will be instead.
- e) If the Peak Mode measured value compliance with and lower than Quasi Peak Mode Limit, the EUT shall be deemed to meet QP (AV) Limits and then no additional QP Mode measurement performed.
- f) For the actual test configuration, please refer to the related Item –EUT Test Photos.

TEST SETUP

(A) Radiated Emission Test Set-Up Frequency Below 1 GHz

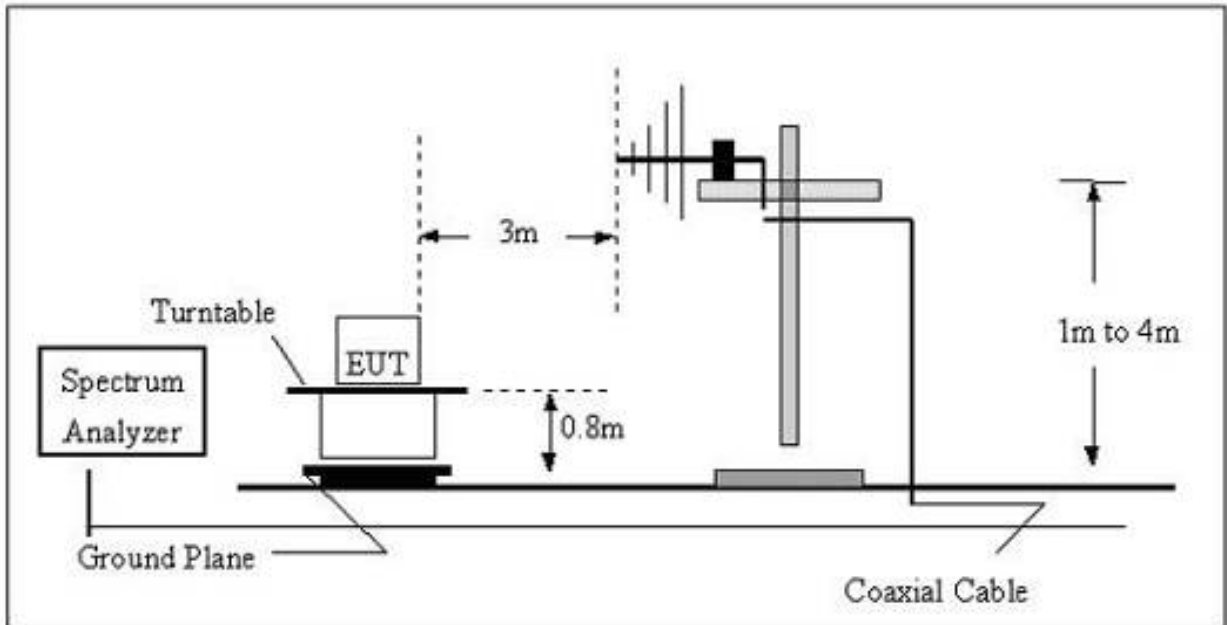

(B) Radiated Emission Test Set-Up Frequency Above 1GHz

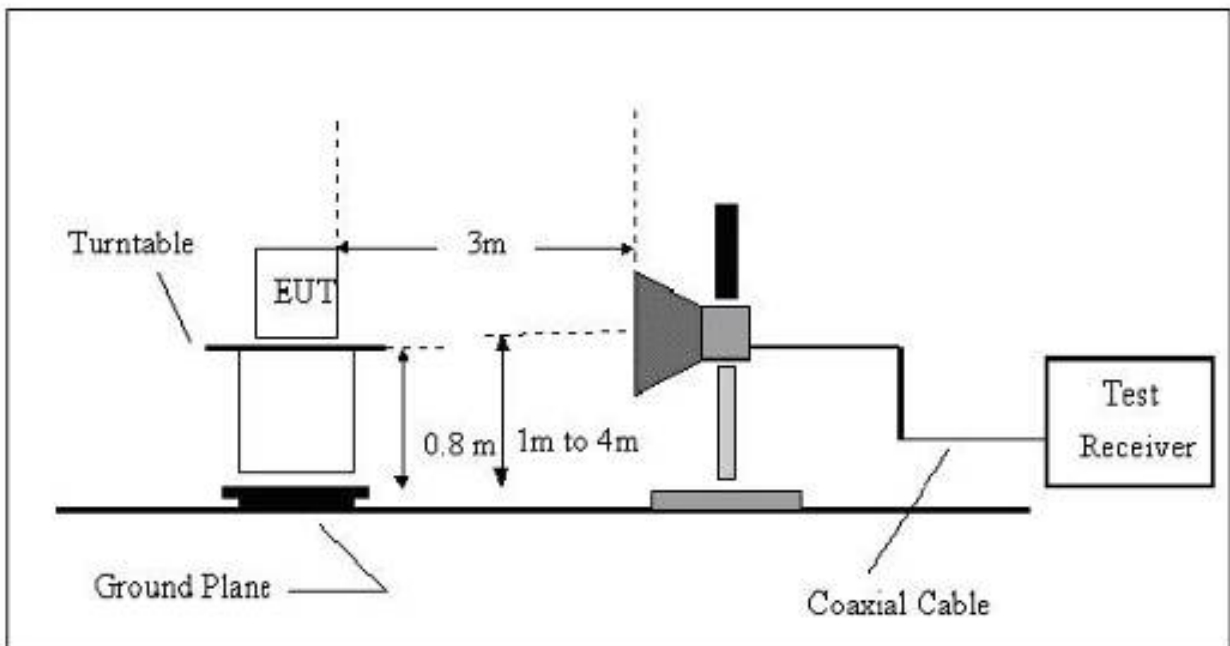

For 30MHz-1GHz

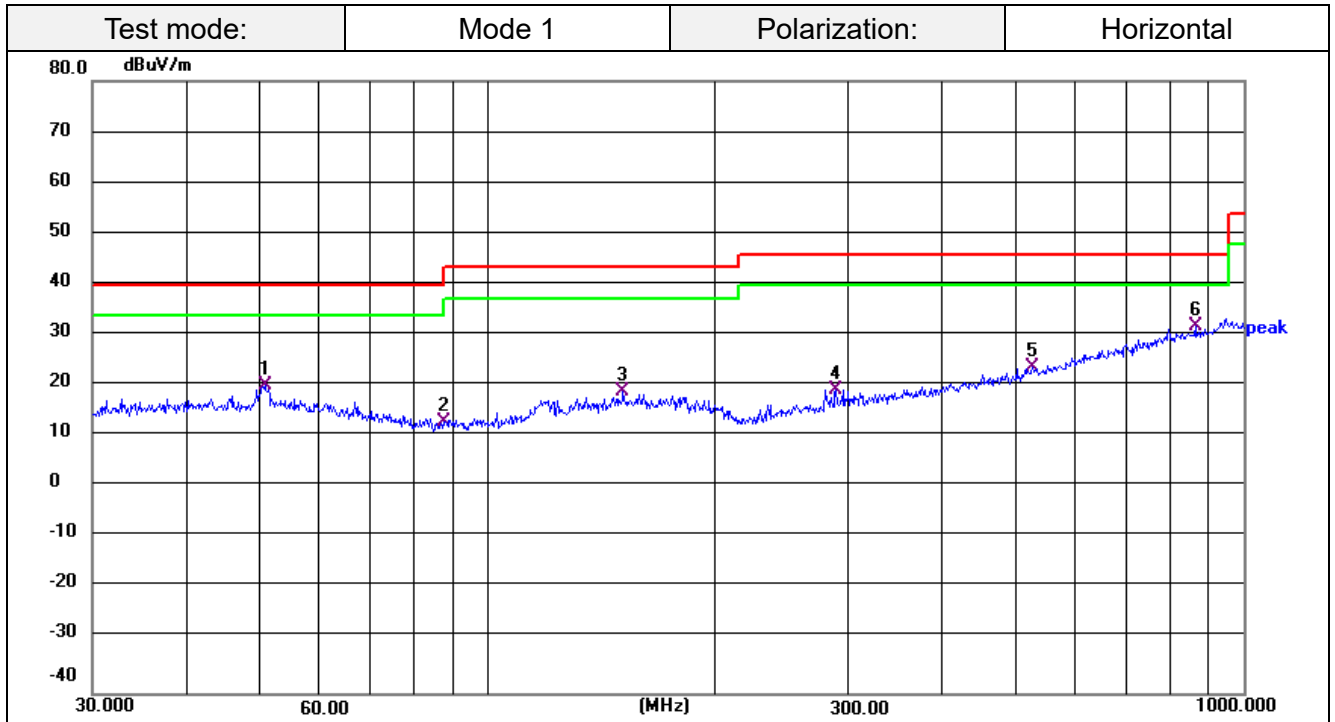

Remark:

Emission Level = Reading + Factor;
 Factor = Antenna Factor + Cable Loss – Pre-amplifier;
 Margin= Emission Level - Limit.

No.	Frequency (MHz)	Reading (dBuV)	Factor (dB/m)	Level (dBuV/m)	Limit (dBuV/m)	Margin (dB)	Det.
1	50.7637	37.06	-16.65	20.41	40.00	-19.59	QP
2	87.4177	34.18	-20.98	13.20	40.00	-26.80	QP
3	151.0666	35.65	-16.51	19.14	43.50	-24.36	QP
4	289.0021	36.93	-17.26	19.67	46.00	-26.33	QP
5	526.3967	35.94	-11.93	24.01	46.00	-21.99	QP
6 *	863.0562	37.29	-5.26	32.03	46.00	-13.97	QP

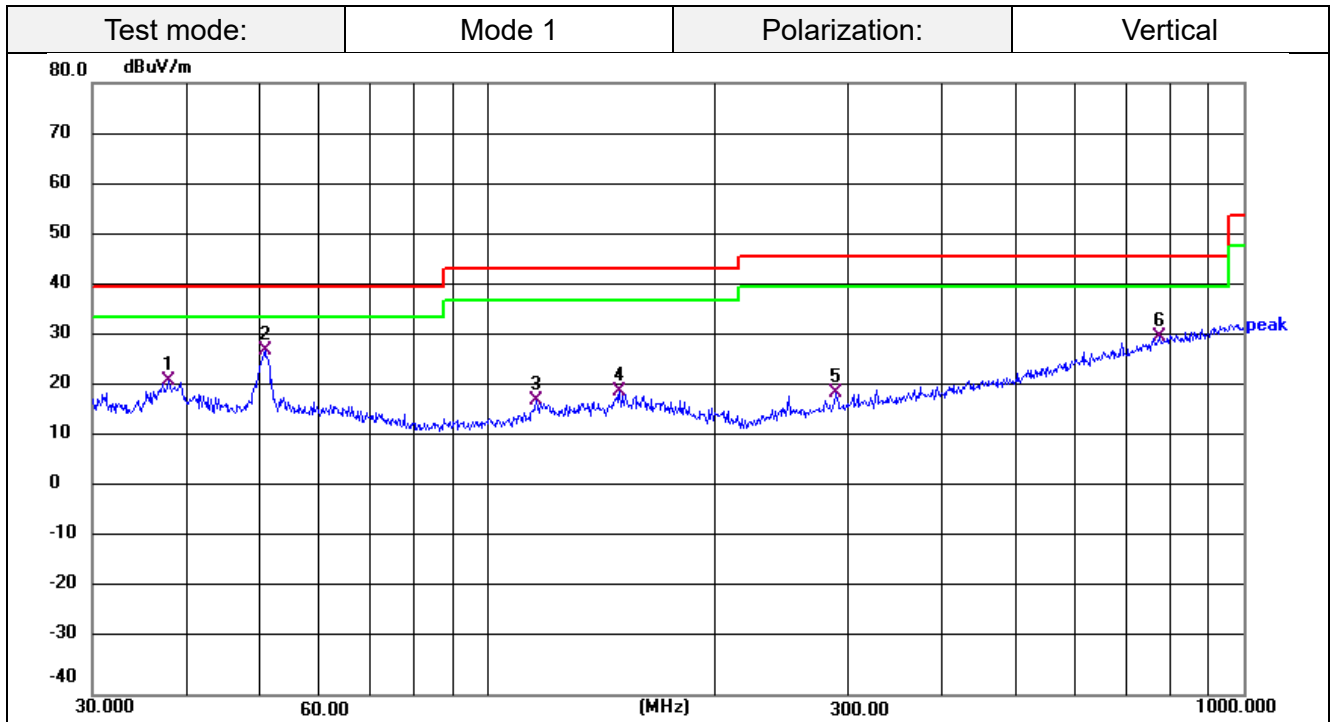

Remark:

Emission Level = Reading + Factor;
 Factor = Antenna Factor + Cable Loss – Pre-amplifier;
 Margin= Emission Level - Limit.

No.	Frequency (MHz)	Reading (dBuV)	Factor (dB/m)	Level (dBuV/m)	Limit (dBuV/m)	Margin (dB)	Det.
1	37.9450	38.41	-16.75	21.66	40.00	-18.34	QP
2 *	50.7637	44.36	-16.65	27.71	40.00	-12.29	QP
3	116.1321	36.61	-18.81	17.80	43.50	-25.70	QP
4	149.4857	36.15	-16.55	19.60	43.50	-23.90	QP
5	289.0021	36.63	-17.26	19.37	46.00	-26.63	QP
6	774.1584	36.72	-6.45	30.27	46.00	-15.73	QP

4 Test Setup Photographs of EUT

Conducted Emission



Radiated Emission 30MHz-1GHZ

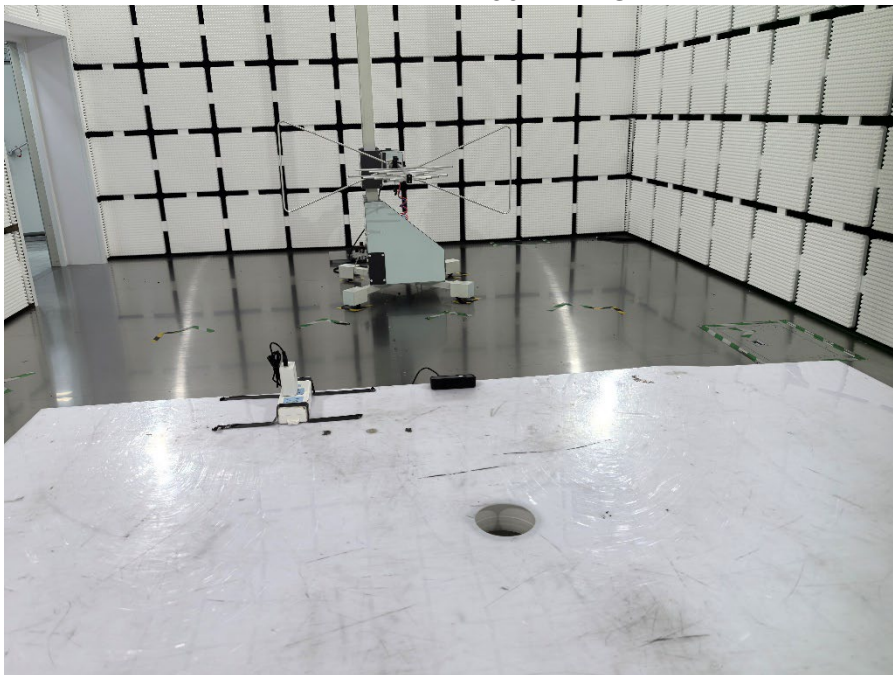

5 External Photographs of EUT

Please refer to separated files for External Photos of the EUT.

6 Internal Photographs of EUT

Please refer to separated files for Internal Photos of the EUT.

******* End of Report *******