



FCC TEST REPORT

FCC ID:2BLPF-Q1PL

Report Number..... : ZKT-241029L14074E-1

Date of Test..... : Sept. 25, 2024, 2024 to Nov. 08, 2024

Date of issue..... : Nov. 08, 2024

Test Result..... : PASS

Testing Laboratory..... : Shenzhen ZKT Technology Co., Ltd.

Address : 1/F, No. 101, Building B, No. 6, Tangwei Community Industrial Avenue, Fuhai Street, Bao'an District, Shenzhen, China

Applicant's name : HUIZHOU SHENSHENG TONG ELECTRONICS CO., LTD.

Address : Room 04, 17th Floor, Unit 2, Building 15, Yuhu Guandi, No.190 Longhai Third Road, Daya Bay West District, Huizhou

Manufacturer's name : HUIZHOU SHENSHENG TONG ELECTRONICS CO., LTD.

Address : Room 04, 17th Floor, Unit 2, Building 15, Yuhu Guandi, No.190 Longhai Third Road, Daya Bay West District, Huizhou

Test specification:

Standard..... : FCC Part 15 Subpart E 15.407
KDB789033 D02 General U-NII Test Procedures New Rules v02r01

Test procedure..... : ANSI C63.10:2013

Non-standard test method : N/A

This device described above has been tested by ZKT, and the test results show that the equipment under test (EUT) is in compliance with the IC requirements. And it is applicable only to the tested sample identified in the report.

This report shall not be reproduced except in full, without the written approval of ZKT, this document may be altered or revised by ZKT, personal only, and shall be noted in the revision of the document.

Product name..... : AI BOX

Trademark : /

Model/Type reference..... : Q1PL, Q1B, Q1BS, Q1BC, Q1BM, Q1BG, Q1BZ, Q1Y, Q1A, Q1F, Q1J, Q1H, Q2K, Q2P, Q2X, Q1L, Q2Y, Q2F, Q3X, Q3H, Q3K, Q2P, Q2M

Model Difference : Q1PL is tested model, other models are derivative models .The models are identical in circuit, only different on the model names. So the test data of Q1PLcan represent the remaining models.

Ratings..... : Input: Type-C DC 5V



Testing procedure and testing location:

Testing Laboratory.....: **Shenzhen ZKT Technology Co., Ltd.**

Address.....: 1/F, No. 101, Building B, No. 6, Tangwei Community Industrial Avenue, Fuhai Street, Bao'an District, Shenzhen, China

Tested by (name + signature).....: Alen He

Reviewer (name + signature).....: Joe Liu

Approved (name + signature).....: Lake Xie



Table of Contents	Page
1. VERSION	6
2.SUMMARY OF TEST RESULTS	7
2.1 TEST FACILITY	8
2.2 MEASUREMENT UNCERTAINTY	8
3. GENERAL INFORMATION	9
3.1 GENERAL DESCRIPTION OF EUT	9
3.3 BLOCK DIGRAM SHOWING THE CONFIGURATION OF SYSTEM TESTED	12
3.4 DESCRIPTION OF SUPPORT UNITS(CONDUCTED MODE)	12
3.5 EQUIPMENTS LIST FOR ALL TEST ITEMS	13
4.EMC EMISSION TEST	15
4.1 CONDUCTED EMISSION MEASUREMENT	15
4.1.1 POWER LINE CONDUCTED EMISSION Limits	15
4.1.2 TEST PROCEDURE	15
4.1.3 DEVIATION FROM TEST STANDARD	15
4.1.4 TEST SETUP	16
4.1.5 EUT OPERATING CONDITIONS	16
4.1.6 TEST RESULTS	17
4.2 RADIATED EMISSION MEASUREMENT	19
4.2.1 APPLICABLE STANDARD	19
4.2.2 CONFORMANCE LIMIT	19
4.2.3 MEASURING INSTRUMENTS	20
4.2.4 TEST CONFIGURATION	21
4.2.5 TEST PROCEDURE	22
5.POWER SPECTRAL DENSITY TEST	31
5.1 APPLIED PROCEDURES / LIMIT	31
5.2 TEST PROCEDURE	32
5.3 DEVIATION FROM STANDARD	32
5.4 TEST SETUP	32
5.5 EUT OPERATION CONDITIONS	32
5.6 TEST RESULTS	33
6. 26DB & 6DB &99% EMISSION BANDWIDTH	34
6.1 APPLIED PROCEDURES / LIMIT	34
6.2 TEST PROCEDURE	34
6.3 EUT OPERATION CONDITIONS	35
6.4 TEST RESULTS	35
7.MAXIMUM CONDUCTED OUTPUT POWER	36
7.1 PLIED PROCEDURES / LIMIT	36



Table of Contents	Page
7.2 TEST PROCEDURE	37
7.3 DEVIATION FROM STANDARD	37
7.4 TEST SETUP	38
7.5 EUT OPERATION CONDITIONS	38
7.6 TEST RESULTS	38
8.OUT OF BAND EMISSIONS	39
8.1 APPLICABLE STANDARD	39
8.2 TEST PROCEDURE	40
8.3 DEVIATION FROM STANDARD	40
8.4 TEST SETUP	40
8.5 EUT OPERATION CONDITIONS	40
8.6 TEST RESULTS	40
9.SPURIOUS RF CONDUCTED EMISSIONS	41
9.1 CONFORMANCE LIMIT	41
9.3 TEST SETUP	41
9.4 TEST PROCEDURE	41
9.5 TEST RESULTS	42
10.FREQUENCY STABILITY MEASUREMENT	43
10.1 LIMIT	43
10.2 TEST PROCEDURES	43
10.3 TEST SETUP LAYOUT	43
10.4 EUT OPERATION DURING TEST	44
10.5 TEST RESULTS	44
11. CHANNEL MOVE TIME, CHANNEL CLOSING TRANSMISSION TIME	45
11.1LIMIT	45
11.2 TEST SETUP LAYOUT	45
11.3TEST PROCEDURE	45
11.4TEST RESULTS	45
12. NON-OCCUPANCY PERIOD TEST	46
12.1LIMIT	46
12.2TEST SETUP LAYOUT	46
13. DFS DETECTION THRESHOLDS	47
13.1LIMIT	47



Table of Contents	Page
13.2 TEST SETUP LAYOUT	47
13.3 TEST RESULTS	47
14. ANTENNA REQUIREMENT	48
15. APPENDIX A. FOR 5G WIFI RF TEST DATA	49
16. TEST SETUP PHOTO	116
17. EUT CONSTRUCTIONAL DETAILS	116



1. VERSION

Report No.	Version	Description	Approved
ZKT-241029L14074E-1	Rev.01	Initial issue of report	Nov. 08, 2024



2.SUMMARY OF TEST RESULTS

Test procedures according to the technical standards:

FCC Part15 (15.407) , Subpart E			
Standard Section	Test Item	Judgment	Remark
15.209(a), 15.407 (b)(1) 15.407 (b)(8)	Spurious Radiated Emissions	PASS	
15.207	Conducted Emission	PASS	
15.407 (a)	26 dB and 99% Emission Bandwidth	PASS	
15.407 (a)(1)	Maximum Conducted Output Power	PASS	
15.407(b)(1)	Band Edge	PASS	
15.407 (a)(1)	Power Spectral Density	PASS	
15.407(b)	Spurious Emissions at Antenna Terminals	PASS	
15.203	Antenna Requirement	PASS	
15.407 (g)	Frequency Stability	PASS	
15.407 (c)	Automatically Discontinue Transmission	NOTE(2)	
15.407(h)(2)(iii)	Channel Move Time, Channel Closing Transmission Time	N/A	
15.407(h)(2)(iv)	Non-Occupancy Period Test	N/A	
KDB 905462 D02, Clause 5.2 Table 3	DFS Detection Thresholds	N/A	

NOTE:

(1) "N/A" denotes test is not applicable in this Test Report

(2)The product meets the requirements of 15.407 (C) standard

Operation in the absence of information to the transmit:

While the EUT is not transmitting any information, the EUT can automatically discontinue transmission and become standby mode for power saving. The EUT can detect the controlling signal of ASK message transmitting from remote device and verify whether it shall resend or discontinue transmission. (manufacturer declare)



2.1 TEST FACILITY

Shenzhen ZKT Technology Co., Ltd.

Add. : 1/F, No. 101, Building B, No. 6, Tangwei Community Industrial Avenue, Fuhai Street, Bao'an District, Shenzhen, China

FCC Test Firm Registration Number: 692225

Designation Number: CN1299

IC Registered No.: 27033

2.2 MEASUREMENT UNCERTAINTY

The reported uncertainty of measurement $y \pm U$, where expanded uncertainty U is based on a standard uncertainty multiplied by a coverage factor of $k=2$, providing a level of confidence of approximately 95%.

No.	Item	Uncertainty
1	3m chamber Radiated spurious emission(30MHz-1GHz)	U=4.3dB
2	3m chamber Radiated spurious emission(1GHz-18GHz)	U=4.5dB
3	3m chamber Radiated spurious emission(18GHz-40GHz)	U=3.34dB
4	Conducted Adjacent channel power	U=1.38dB
5	All emissions radiated(9k-30MHz)	U=4.68dB
6	Conducted output power uncertainty Above 1G	U=1.576dB
7	Conducted output power uncertainty below 1G	U=1.28dB
8	humidity uncertainty	U=5.3%
9	Temperature uncertainty	U=0.59°C
10	Radiated disturbance(30MHz-1000MHz)	U=4.8dB
11	Radiated disturbance(1GHz-6GHz)	U=4.9dB
12	Radiated disturbance(1GHz-18GHz)	U=5.0dB
13	Occupied Bandwidth	U=4.96dB
14	RF Power Density	U=0.77dB



3. GENERAL INFORMATION

3.1 GENERAL DESCRIPTION OF EUT

Product Name:	AI BOX	
Test Model No.:	Q1PL, Q1PL-1	
Product Description	IEEE 802.11 WLAN Mode Supported	<input checked="" type="checkbox"/> 802.11a/n/ac (20MHz channel bandwidth) <input checked="" type="checkbox"/> 802.11n/ac (40MHz channel bandwidth) <input checked="" type="checkbox"/> 802.11ac(80MHz channel bandwidth)
	Data Rate	802.11a: 6,9,12,18,24,36,48,54Mbps; 802.11n/ac(HT20/HT40):MCS0-MCS7; 802.11ac(VHT80):NSS1, MCS0-MCS9
	Modulation	OFDM with BPSK/QPSK/16QAM/64QAM/256QAM for 802.11a/n/ac;
	Operating Frequency Range	<input checked="" type="checkbox"/> 5180-5240MHz for 802.11a/n(HT20)/ac20; 5190-5230MHz for 802.11n(HT40)/ac40; 5210MHz for 802.11 ac80; <input type="checkbox"/> 5260-5320MHz for 802.11a/n(HT20)/ac20; 5270-5310MHz for 802.11n(HT40)/ac40; 5290MHz for 802.11 ac80; <input type="checkbox"/> 5500-5700MHz for 802.11a/n(HT20)/ac20; 5510-5670MHz for 802.11n(HT40)/ac40; 5530-5690MHz for 802.11 ac80; <input type="checkbox"/> 5745-5825 MHz for802.11a/n(HT20)/ac20; 5755-5795 MHz for 802.11a/n(HT40)/ac40; 5775MHz for 802.11 ac80;
	Number of Channels	<input checked="" type="checkbox"/> 4 channels for 802.11a/n20/ac20 in the 5180-5240MHz band ; 2 channels for 802.11 n40/ac40 in the 5190-5230 MHz band ; 1 channels for 802.11 ac80 in the 5210MHz band ; <input type="checkbox"/> 4 channels for 802.11a/n20/ac20 in the 5260-5320MHz band ; 2 channels for 802.11 n40/ac40 in the 5270-5310 MHz band ; 1 channels for 802.11 ac80 in the 5290MHz band ; <input type="checkbox"/> 11 channels for 802.11a/n20/ac20 in the 5500-5700MHz band ; 5 channels for 802.11 n40/ac40 in the 5510-5670 MHz band ; 3 channels for 802.11 ac80 in the 5530-5690MHz band ; <input type="checkbox"/> 5 channels for 802.11a/n20/ac20 in the 5745-5825MHz band ; 2 channels for 802.11 n40/ac40 in the 5755-5795 MHz band ; 1 channels for 802.11 ac80 in the 5775MHz band ;
Channel List	Please refer to the Note 2.	
Antenna Type and Antenna gain:	PCB Antenna, ANT: 3.48dBi	
Worst Case:	5.2G WIFI 802.11a	
Power supply:	Input: Type-C DC 5V	

Note:

For a more detailed features description, please refer to the manufacturer's specifications or the User's Manual.



802.11a/n/ac(20MHz) Frequency Channel							
Channel	Frequency (MHz)	Channel	Frequency (MHz)	Channel	Frequency (MHz)	Channel	Frequency (MHz)
36	5180	40	5200	44	5220	48	5240

802.11n(40MHz) Frequency Channel							
802.11n /ac(40MHz)Frequency Channel							
Channel	Frequency (MHz)	Channel	Frequency (MHz)	Channel	Frequency (MHz)	Channel	Frequency (MHz)
38	5190	46	5230				

802.11ac(80MHz) Frequency Channel	
Channel	Frequency (MHz)
42	5210



3.2 DESCRIPTION OF TEST MODES

Transmitting mode	Keep the EUT in continuously transmitting mode
Remark: During the test, the test voltage was tuned from 85% to 115% of the nominal rated supply voltage, and found that the worst case was under the nominal rated supply condition. So the report just shows that condition's data.	

Pretest Mode	Description
Mode 1	802.11a / n20/ac 20/ CH36/ CH40/ CH48
Mode 2	802.11n 40/ac40 CH38/ CH46
Mode 3	802.11 ac80 CH42

For Radiated Emission	
Final Test Mode	Description
Mode 1	802.11a / n20/ac 20/ CH36/ CH40/ CH48
Mode 2	802.11n 40/ac40 CH38/ CH46
Mode 3	802.11 ac80 CH42

Note:

(1) The measurements are performed at all Bit Rate of Transmitter, the worst data was reported.



3.3 BLOCK DIGRAM SHOWING THE CONFIGURATION OF SYSTEM TESTED

Conducted Emission

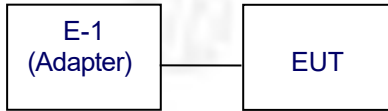

Radiated Emission

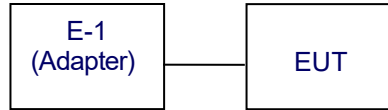

3.4 DESCRIPTION OF SUPPORT UNITS(CONDUCTED MODE)

The EUT has been tested as an independent unit together with other necessary accessories or support units. The following support units or accessories were used to form a representative test configuration during the tests.

Item	Equipment	Mfr/Brand	Model/Type No.	Series No.	Note
E-1	Adapter	/	KN-CA018005	/	EUT

Item	Shielded Type	Ferrite Core	Length	Note

Note:

- (1) The support equipment was authorized by Declaration of Confirmation.
- (2) For detachable type I/O cable should be specified the length in cm in 『Length』 column.



3.5 EQUIPMENTS LIST FOR ALL TEST ITEMS

Radiation Test equipment

Item	Equipment	Manufacturer	Type No.	Serial No.	Firmware Version	Last calibration	Calibrated until
1	Spectrum Analyzer (9kHz-26.5GHz)	KEYSIGHT	9020A	MY55370835	A.17.05	Nov. 02, 2023	Nov. 01, 2024
2	Spectrum Analyzer (10kHz-39.9GHz)	R&S	FSV40-N	100363	1.71 SP2	Nov. 02, 2023	Nov. 01, 2024
3	EMI Test Receiver (9kHz-7GHz)	R&S	ESCI7	100969	4.32	Nov. 02, 2023	Nov. 01, 2024
4	Bilog Antenna (30MHz-1500MHz)	Schwarzbeck	VULB9168	N/A	N/A	Nov. 13, 2023	Nov. 12, 2024
5	Horn Antenna (1GHz-18GHz)	Agilent	AH-118	071145	N/A	Nov. 13, 2023	Nov. 12, 2024
6	Horn Antenna (15GHz-40GHz)	A.H.System	SAS-574	588	N/A	Nov. 13, 2023	Nov. 12, 2024
7	Loop Antenna	TESEQ	HLA6121	58357	N/A	Nov. 16, 2023	Nov. 15, 2024
8	Amplifier (30-1000MHz)	EM Electronics	EM330 Amplifier	60747	N/A	Nov. 02, 2023	Nov. 01, 2024
9	Amplifier (1GHz-26.5GHz)	HuiPu	8449B	3008A00315	N/A	Nov. 02, 2023	Nov. 01, 2024
10	Amplifier (500MHz-40GHz)	QuanJuDa	DLE-161	097	N/A	Nov. 02, 2023	Nov. 01, 2024
11	Test Cable	N/A	R-01	N/A	N/A	Nov. 02, 2023	Nov. 01, 2024
12	Test Cable	N/A	R-02	N/A	N/A	Nov. 02, 2023	Nov. 01, 2024
13	Test Cable	N/A	R-03	N/A	N/A	Nov. 02, 2023	Nov. 01, 2024
14	Test Cable	N/A	RF-01	N/A	N/A	Nov. 02, 2023	Nov. 01, 2024
15	Test Cable	N/A	RF-02	N/A	N/A	Nov. 02, 2023	Nov. 01, 2024
16	Test Cable	N/A	RF-03	N/A	N/A	Nov. 02, 2023	Nov. 01, 2024
17	ESG Signal Generator	Agilent	E4421B	N/A	B.03.84	Nov. 02, 2023	Nov. 01, 2024
18	Signal Generator	Agilent	N5182A	N/A	A.01.87	Nov. 02, 2023	Nov. 01, 2024
19	Magnetic Field Probe Tester	Narda	ELT-400	0-0344	N/A	Nov. 16, 2023	Nov. 15, 2024
20	Wideband Radio Communication Test	R&S	CMW500	106504	V 3.7.22	Nov. 02, 2023	Nov. 01, 2024
21	MWRF Power Meter Test system	MW	MW100-RF CB	N/A	N/A	Nov. 02, 2023	Nov. 01, 2024
22	D.C. Power Supply	LongWei	TPR-6405D	N/A	N/A	\	\
23	EMC Software	Frad	EZ-EMC	Ver.EMC-CO N 3A1.1	N/A	\	\
24	RF Software	MW	MTS8310	V2.0.0.0	N/A	\	\
25	Turntable	MF	MF-7802BS	N/A	N/A	\	\
26	Antenna tower	MF	MF-7802BS	N/A	N/A	\	\



Conduction Test equipment

Item	Kind of Equipment	Manufacturer	Type No.	Serial No.	Firmware Version	Last calibration	Calibrated until
1	LISN	R&S	ENV216	101471	N/A	Nov. 14, 2023	Nov. 13, 2024
2	LISN	CYBERTEK	EM5040A	E1850400149	N/A	Nov. 02, 2023	Nov. 01, 2024
3	Test Cable	N/A	C-01	N/A	N/A	Nov. 02, 2023	Nov. 01, 2024
4	Test Cable	N/A	C-02	N/A	N/A	Nov. 02, 2023	Nov. 01, 2024
5	Test Cable	N/A	C-03	N/A	N/A	Nov. 02, 2023	Nov. 01, 2024
6	EMI Test Receiver	R&S	ESCI3	101393	4.42 SP3	Nov. 02, 2023	Nov. 01, 2024
7	Triple-Loop Antenna	N/A	RF300	N/A	N/A	Nov. 02, 2023	Nov. 01, 2024
8	Absorbing Clamp	DZ	ZN23201	15034	N/A	Nov. 07, 2023	Nov. 06, 2024
9	EMC Software	Frad	EZ-EMC	Ver.EMC-CON 3A1.1	N/A	\	\



4.EMC EMISSION TEST

4.1 CONDUCTED EMISSION MEASUREMENT

Test Requirement:	FCC Part15 C Section 15.207, RSS-Gen 8.8
Test Method:	ANSI C63.10:2013
Test Frequency Range:	150KHz to 30MHz
Receiver setup:	RBW=9KHz, VBW=30KHz, Sweep time=auto

4.1.1 POWER LINE CONDUCTED EMISSION Limits

FREQUENCY (MHz)	Limit (dBuV)		Standard
	Quasi-peak	Average	
0.15 -0.5	66 - 56 *	56 - 46 *	FCC
0.50 -5.0	56.00	46.00	FCC
5.0 -30.0	60.00	50.00	FCC

Note:

(1) *Decreases with the logarithm of the frequency.

4.1.2 TEST PROCEDURE

- a. The EUT was placed 0.8 meters from the horizontal ground plane with EUT being connected to the power mains through a line impedance stabilization network (LISN). All other support equipments powered from additional LISN(s). The LISN provide 50 Ohm/ 50uH of coupling impedance for the measuring instrument.
- b. Interconnecting cables that hang closer than 40 cm to the ground plane shall be folded back and forth in the center forming a bundle 30 to 40 cm long.
- c. I/O cables that are not connected to a peripheral shall be bundled in the center. The end of the cable may be terminated, if required, using the correct terminating impedance. The overall length shall not exceed 1 m.
- d. LISN at least 80 cm from nearest part of EUT chassis.
- e. For the actual test configuration, please refer to the related Item –EUT Test Photos.

4.1.3 DEVIATION FROM TEST STANDARD

No deviation



4.1.4 TEST SETUP

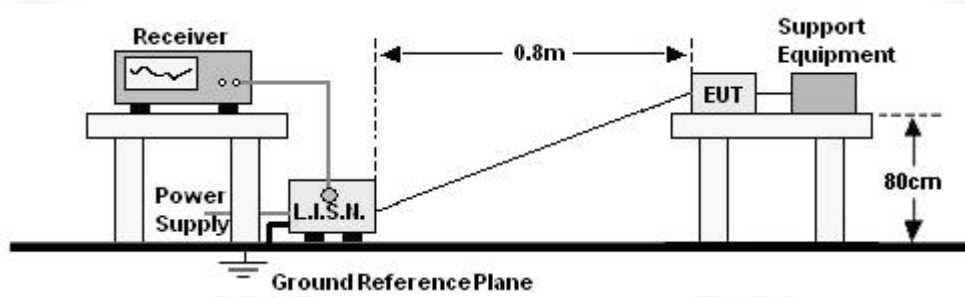

4.1.5 EUT OPERATING CONDITIONS

The EUT was configured for testing in a typical fashion (as a customer would normally use it). The EUT has been programmed to continuously transmit during test. This operating condition was tested and used to collect the included data.



4.1.6 TEST RESULTS

Temperature:	24.3°C	Relative Humidity :	50%
Pressure:	101kPa	Phase :	L
Test Voltage:	AC 120V/60Hz		

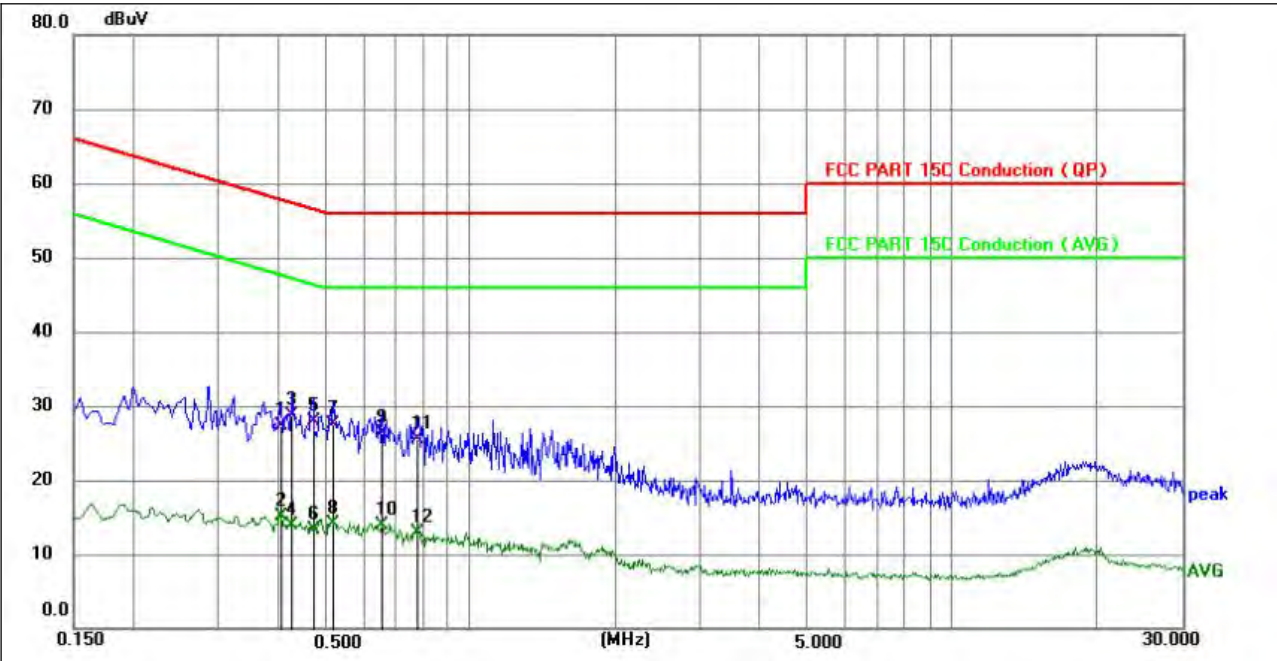

No.	Frequency (MHz)	Reading (dBuV)	Factor (dB)	Level (dBuV)	Limit (dBuV)	Margin (dB)	Detector	P/F	Remark
1	0.4020	17.27	9.98	27.25	57.81	-30.56	QP	P	
2	0.4020	5.20	9.98	15.18	47.81	-32.63	AVG	P	
3	0.4244	18.64	9.99	28.63	57.36	-28.73	QP	P	
4	0.4244	3.96	9.99	13.95	47.36	-33.41	AVG	P	
5 *	0.4694	17.95	10.00	27.95	56.52	-28.57	QP	P	
6	0.4694	3.26	10.00	13.26	46.52	-33.26	AVG	P	
7	0.5190	17.39	10.02	27.41	56.00	-28.59	QP	P	
8	0.5190	4.16	10.02	14.18	46.00	-31.82	AVG	P	
9	0.6540	16.30	10.03	26.33	56.00	-29.67	QP	P	
10	0.6540	3.78	10.03	13.81	46.00	-32.19	AVG	P	
11	0.7799	15.37	10.04	25.41	56.00	-30.59	QP	P	
12	0.7799	2.88	10.04	12.92	46.00	-33.08	AVG	P	

Notes:

- 1.An initial pre-scan was performed on the line and neutral lines with peak detector.
- 2.Quasi-Peak and Average measurement were performed at the frequencies with maximized peak emission.
- 3.Measurement Level = Reading level + Correct Factor
- 4.All mode have been tested,The worst mode is 5.2G 802.11a 5180MHz is recorded.



Temperature:	24.3°C	Relative Humidity :	50%
Pressure:	101kPa	Phase :	N
Test Voltage:	AC 120V/60Hz		

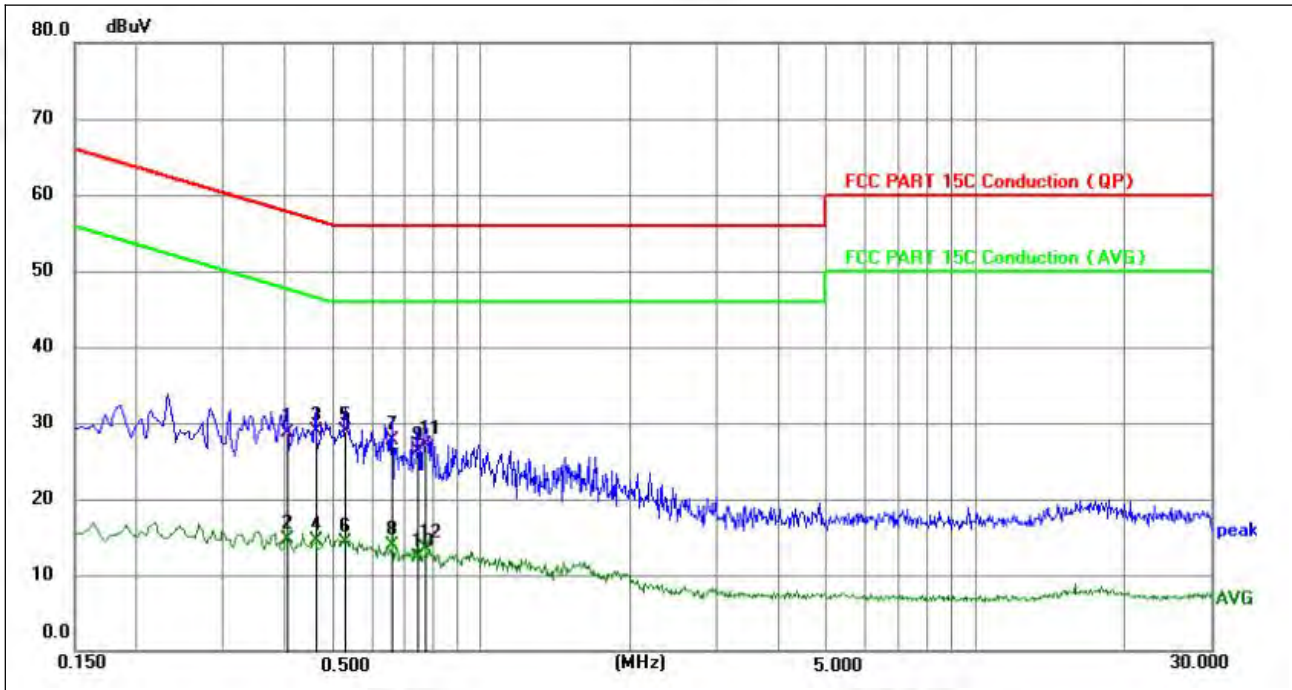

No.	Frequency (MHz)	Reading (dBuV)	Factor (dB)	Level (dBuV)	Limit (dBuV)	Margin (dB)	Detector	P/F	Remark
1	0.4020	18.74	9.98	28.72	57.81	-29.09	QP	P	
2	0.4020	4.82	9.98	14.80	47.81	-33.01	AVG	P	
3	0.4605	18.93	10.01	28.94	56.68	-27.74	QP	P	
4	0.4605	4.50	10.01	14.51	46.68	-32.17	AVG	P	
5 *	0.5280	18.82	10.02	28.84	56.00	-27.16	QP	P	
6	0.5280	4.23	10.02	14.25	46.00	-31.75	AVG	P	
7	0.6584	17.77	10.03	27.80	56.00	-28.20	QP	P	
8	0.6584	3.84	10.03	13.87	46.00	-32.13	AVG	P	
9	0.7440	16.28	10.04	26.32	56.00	-29.68	QP	P	
10	0.7440	2.27	10.04	12.31	46.00	-33.69	AVG	P	
11	0.7710	17.11	10.04	27.15	56.00	-28.85	QP	P	
12	0.7710	3.47	10.04	13.51	46.00	-32.49	AVG	P	

Notes:

- 1.An initial pre-scan was performed on the line and neutral lines with peak detector.
- 2.Quasi-Peak and Average measurement were performed at the frequencies with maximized peak emission.
- 3.Measurement Level = Reading level + Correct Factor
- 4.All mode have been tested,The worst mode is 5.2G 802.11a 5180MHz is recorded.



4.2 RADIATED EMISSION MEASUREMENT

4.2.1 APPLICABLE STANDARD

According to FCC Part 15.407(d) and 15.209, RSS-247 6.2.1.2, RSS-Gen

4.2.2 CONFORMANCE LIMIT

According to FCC Part 15.407(b)(7): radiated emissions which fall in the restricted bands, as defined in §15.205(a), must also comply with the radiated emission limits specified in §15.209(a) (see §15.205(c)).

According to FCC Part 15.205, Restricted bands

MHz	MHz	MHz	GHz
0.090-0.110	16.42-16.423	399.9-410	4.5-5.15
10.495-0.505	16.69475-16.69525	608-614	5.35-5.46
2.1735-2.1905	16.80425-16.80475	960-1240	7.25-7.75
4.125-4.128	25.5-25.67	1300-1427	8.025-8.5
4.17725-4.17775	37.5-38.25	1435-1626.5	9.0-9.2
4.20725-4.20775	73-74.6	1645.5-1646.5	9.3-9.5
6.215-6.218	74.8-75.2	1660-1710	10.6-12.7
6.26775-6.26825	123-138	2200-2300	14.47-14.5
8.291-8.294	149.9-150.05	2310-2390	15.35-16.2
8.362-8.366	156.52475-156.52525	2483.5-2500	17.7-21.4
8.37625-8.38675	156.7-156.9	2690-2900	22.01-23.12
8.41425-8.41475	162.0125-167.17	3260-3267	23.6-24.0
12.29-12.293	167.72-173.2	3332-3339	31.2-31.8
12.51975-12.52025	240-285	3345.8-3358	36.43-36.5
12.57675-12.57725	322-335.4	3600-4400	(2)
13.36-13.41			

RSS-Gen 8.10 Restricted frequency bands

MHz	MHz	MHz	GHz
0.090 - 0.110	13.36 - 13.41	960 - 1427	9.0 - 9.2
0.495 - 0.505	16.42 - 16.423	1435 - 1626.5	9.3 - 9.5
2.1735 - 2.1905	16.69475 - 16.69525	1645.5 - 1646.5	10.6 - 12.7
3.020 - 3.026	16.80425 - 16.80475	1660 - 1710	13.25 - 13.4
4.125 - 4.128	25.5 - 25.67	1718.8 - 1722.2	14.47 - 14.5
4.17725 - 4.17775	37.5 - 38.25	2200 - 2300	15.35 - 16.2
4.20725 - 4.20775	73 - 74.6	2310 - 2390	17.7 - 21.4
5.677 - 5.683	74.8 - 75.2	2483.5 - 2500	22.01 - 23.12
6.215 - 6.218	108 - 138	2655 - 2900	23.6 - 24.0
6.26775 - 6.26825	149.9 - 150.05	3260 - 3267	31.2 - 31.8
6.31175 - 6.31225	156.52475-156.52525	3332 - 3339	36.43 - 36.5
8.291 - 8.294	156.7 - 156.9	3345.8 - 3358	Above 38.6
8.362 - 8.366	162.0125 - 167.17	3500 - 4400	
8.37625 - 8.38675	167.72 - 173.2	4500 - 5150	
8.41425 - 8.41475	240 - 285	5350 - 5460	
12.29 - 12.293	322 - 335.4	7250 - 7750	
12.51975 - 12.52025	399.9 - 410	8025 - 8500	
12.57675 - 12.57725	608 - 614		



Limits of Radiated Emission Measurement(Above 1000MHz)

Frequency(MHz)	Class B (dBuV/m) (at 3M)	
	PEAK	AVERAGE
Above 1000	74	54

Remark :1. Emission level in dBuV/m=20 log (uV/m)

2. Measurement was performed at an antenna to the closed point of EUT distance of meters.

3. Distance extrapolation factor =40log(Specific distance/ test distance)(dB);

Limit line=Specific limits(dBuV) + distance extrapolation factor.

Limits of unwanted emission out of the restricted bands

Frequency (MHz)	EIRP Limits (dBm)	Equivalent Field Strength at 3m (dBuV/m)
5150~5250	-27	68.2
5250~5350	-27	68.2
5470~5725	-27	68.2
5725~5850	-27(Note 2)	68.2
	10(Note 2)	105.2
	15.6(Note 2)	110.8
	27(Note 2)	122.2

NOTE:

1, The following formula is used to convert the equipment isotropic radiated power (eirp) to field strength:

$$E = \frac{1000000\sqrt{30P}}{3} \text{ uV/m, where P is the eirp (Watts)}$$

2, According to FCC 16-24, All emissions shall be limited to a level of -27 dBm/MHz at 75 MHz or more above or below the band edge increasing linearly to 10 dBm/MHz at 25 MHz above or below the band edge, and from 25MHz above or below the band edge increasing linearly to a level of 15.6 dBm/MHz at 5 MHz above or below the band edge, and from 5 MHz above or below the band edge increasing linearly to a level of 27dBm/MHz at the band edge.

According to RSS-Gen§8.9: In any 100 kHz bandwidth outside the frequency band in which the spread spectrum or digitally modulated device is operating, the RF power that is produced shall be at least 20 dB below that in the 100 kHz bandwidth within the band that contains the highest level of the desired power, based on either an RF conducted or a radiated measurement, provided that the transmitter demonstrates compliance with the peak conducted power limits. If the transmitter complies with the conducted power limits based on the use of root-mean-square averaging over a time interval, as permitted under Section 5.4(4), the attenuation required shall be 30 dB instead of 20 dB. Attenuation below the general field

strength limits specified in RSS-Gen Issue 5 is not required.

In case the emission fall within the restricted band specified on RSS-Gen Issue 5, then the RSS-Gen Issue 5 limit in the table below has to be followed.

Frequency (MHz)	Distance (Meters)	Radiated (dBuV/m)	Radiated (uV/m)
0.009-0.49	3	20log(2400/F(KHz))+40log(300/3)	2400/F(KHz)
0.49-1.705	3	20log(24000/F(KHz))+ 40log(30/3)	24000/F(KHz)
1.705-30	3	20log(30)+ 40log(30/3)	30
30-88	3	40.0	100
88-216	3	43.5	150
216-960	3	46.0	200
Above 960	3	54.0	500

4.2.3 MEASURING INSTRUMENTS

The Measuring equipment is listed in the section 6.3 of this test report.



4.2.4 TEST CONFIGURATION

1. For radiated emissions below 30MHz

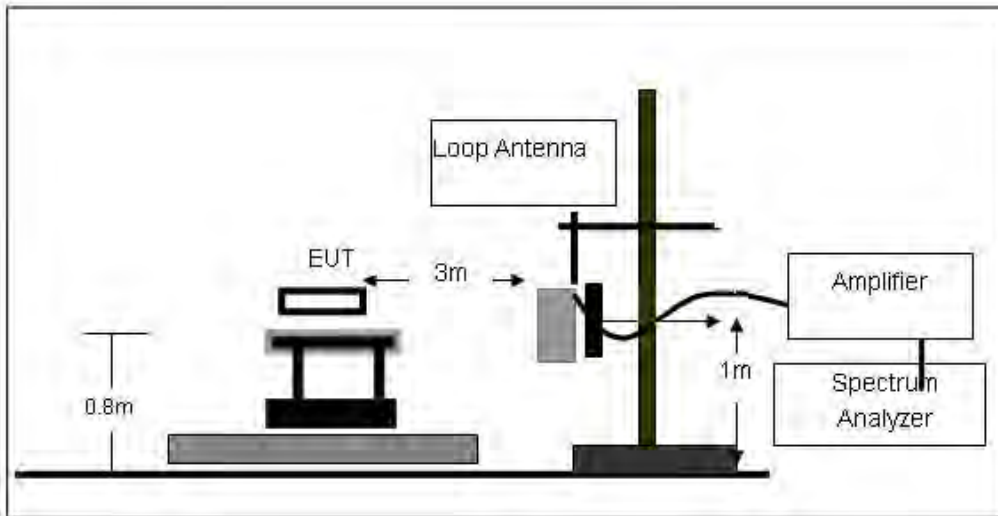

2. For radiated emissions from 30MHz to 1000MHz

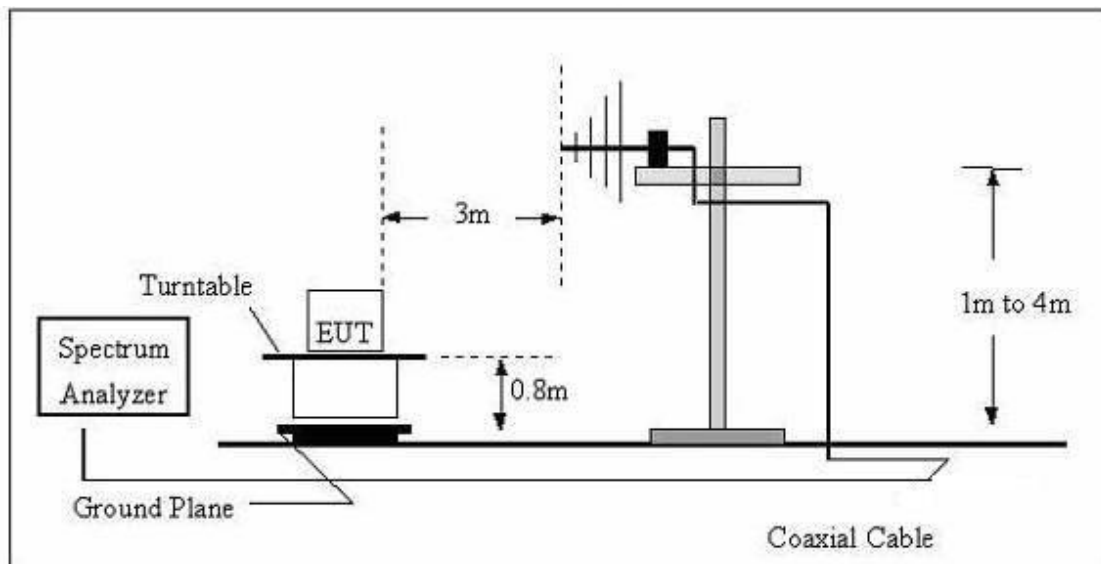

3. Radiated Emission Test-Up Frequency Above 1GHz

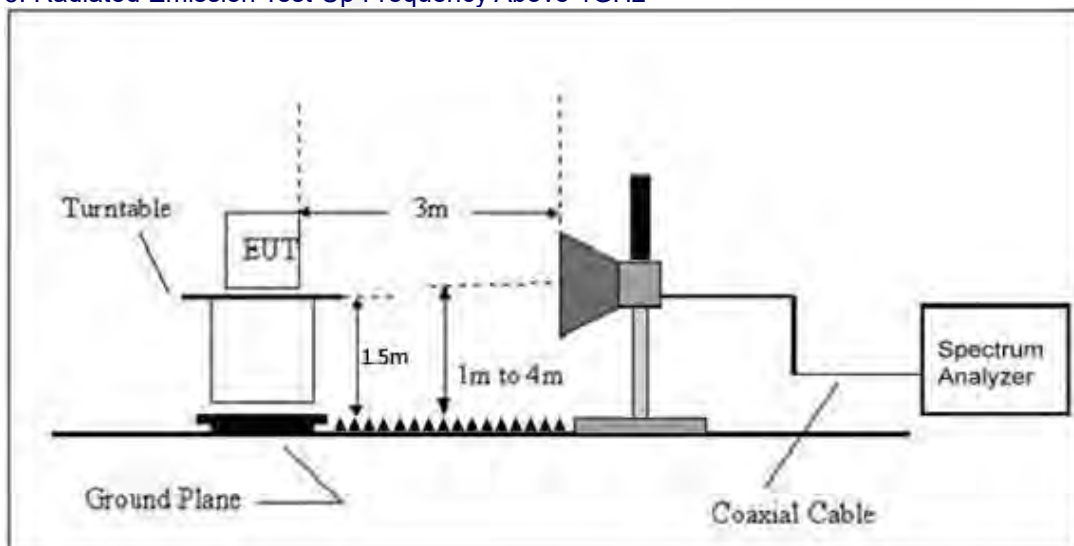



4.2.5 TEST PROCEDURE

The test site semi-anechoic chamber has met the requirement of NSA tolerance 4 dB according to the standards: ANSI C63.10-2013. The test distance is 3m. The setup is according to the requirements in Section 13.1.4.1 of ANSI C63.10-2013 and CAN/CSA-CEI/IEC CISPR 22.

This test is required for any spurious emission that falls in a Restricted Band, as defined in Section 15.205. It must be performed with the highest gain of each type of antenna proposed for use with the EUT.

Use the following spectrum analyzer settings:

Spectrum Parameter	Setting
Attenuation	Auto
Start Frequency	1000 MHz
Stop Frequency	10th carrier harmonic
RB / VB (emission in restricted band)	1 MHz / 1 MHz for Peak, 1 MHz / 10Hz for Average

Receiver Parameter	Setting
Attenuation	Auto
Start ~ Stop Frequency	9kHz~150kHz / RB 200Hz for QP
Start ~ Stop Frequency	150kHz~30MHz / RB 9kHz for QP
Start ~ Stop Frequency	30MHz~1000MHz / RB 120kHz for QP

- The measuring distance of at 3 m shall be used for measurements at frequency up to 1GHz. For frequencies above 1GHz, any suitable measuring distance may be used.
- The EUT was placed on the top of a rotating table 0.8 m for below 1GHz and 1.5m for above 1GHz the ground at a 3 meter. The table was rotated 360 degrees to determine the position of the highest radiation.
- The height of the equipment or of the substitution antenna shall be 0.8 m for below 1GHz and 1.5m for above 1GHz; the height of the test antenna shall vary between 1 m to 4 m. Both horizontal and vertical polarizations of the antenna are set to make the measurement.
- The initial step in collecting conducted emission data is a spectrum analyzer peak detector mode pre-scanning the measurement frequency range. Significant peaks are then marked and then Quasi Peak detector mode re-measured.
- If the Peak Mode measured value compliance with and lower than Quasi Peak Mode Limit, the EUT shall be deemed to meet QP Limits and then no additional QP Mode measurement performed.
- For the actual test configuration, please refer to the related Item –EUT Test Photos.

Note:

Both horizontal and vertical antenna polarities were tested and performed pretest to three orthogonal axis. The worst case emissions were reported

During the radiated emission test, the Spectrum Analyzer was set with the following configurations:

Frequency Band (MHz)	Function	Resolution bandwidth	Video Bandwidth
30 to 1000	QP	120 kHz	300 kHz
Above 1000	Peak	1 MHz	1 MHz
	Average	1 MHz	10 Hz

Note: for the frequency ranges below 30 MHz, a narrower RBW is used for these ranges but the measured value should add a RBW correction factor (RBWCF) where $RBWCF [dB] = 10 \cdot \lg(100 [kHz]/\text{narrower RBW [kHz]})$, the narrower RBW is 1 kHz and RBWCF is 20 dB for the frequency 9 kHz to 150 kHz, and the narrower RBW is 10 kHz and RBWCF is 10 dB for the frequency 150 kHz to 30 MHz.

4.2.6 TEST RESULT(Between 9KHz – 30MHz)

The emission from 9 kHz to 30MHz was pre-tested and found the result was 20dB lower than the limit, and according to 15.31(o) & RSS-Gen 6.13, the test result no need to reported.



Between 30MHz – 1GHz

Temperature:	25.2°C	Relative Humidity:	50%
Pressure:	1010kPa	Polarization:	Horizontal
Test Voltage:	AC 120V/60Hz		

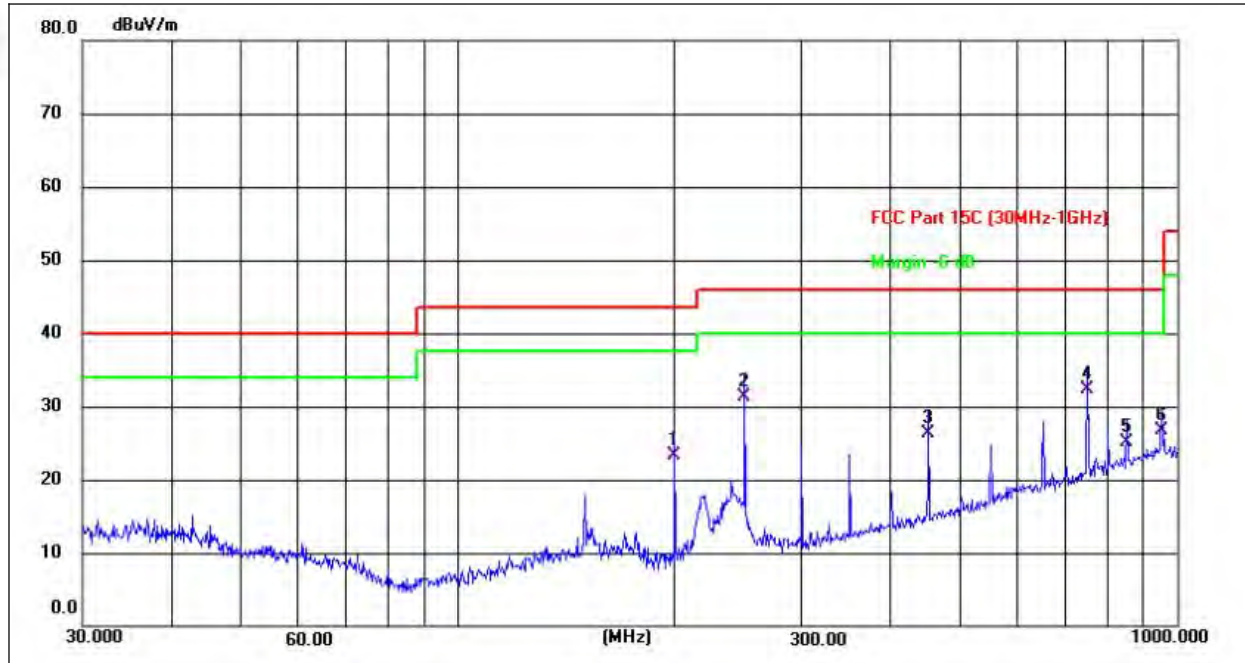

No.	Frequency (MHz)	Reading (dBuV)	Factor (dB/m)	Level (dBuV/m)	Limit (dBuV/m)	Margin (dB)	Detector
1	199.9855	41.53	-18.19	23.34	43.50	-20.16	QP
2	250.3011	47.28	-15.95	31.33	46.00	-14.67	QP
3	451.1350	37.26	-10.90	26.36	46.00	-19.64	QP
4 *	750.1082	37.24	-4.99	32.25	46.00	-13.75	QP
5	851.0353	28.39	-3.35	25.04	46.00	-20.96	QP
6	952.0937	28.83	-2.12	26.71	46.00	-19.29	QP



Temperature:	25.2°C	Relative Humidity:	50%
Pressure:	1010kPa	Polarization:	Vertical
Test Voltage:	AC 120V/60Hz		

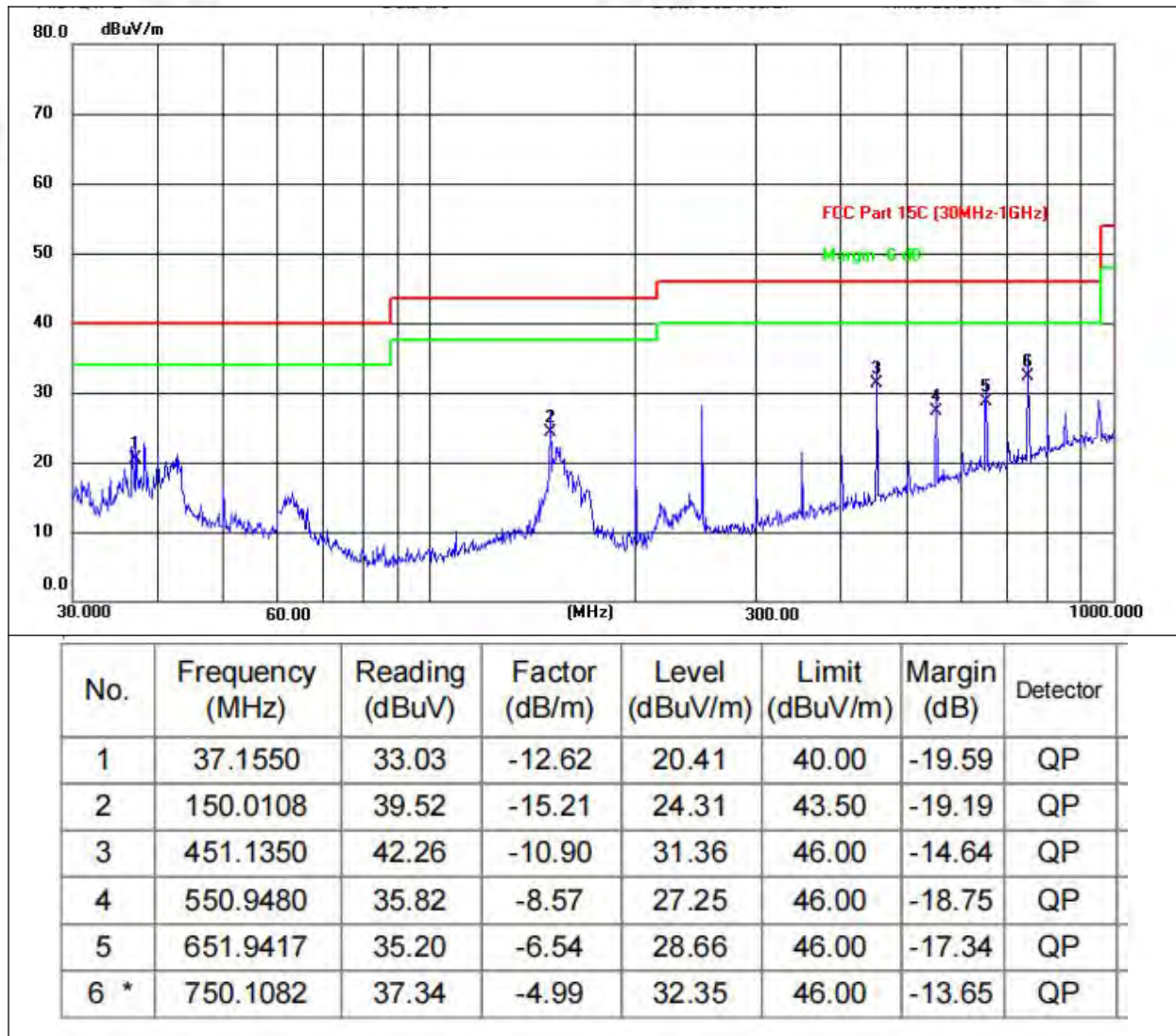

Remarks:

- 1.Final Level =Receiver Read level + Antenna Factor + Cable Loss – Preamplifier Factor
- 2.The emission levels of other frequencies are very lower than the limit and not show in test report.
- 3.All mode have been tested,The worst mode is 5.2G 802.11a 5180MHz is recorded.



Between 1GHz – 40GHz

Temperature :	24.2°C	Relative Humidity:	54%
Pressure :	1010 hPa	Test Voltage :	AC 120V/60Hz

802.11a

Polar (H/V)	Frequency	Meter Reading	Pre-amplifier	Cable Loss	Antenna Factor	Emission Level	Limits	Margin	Detect or Type
	(MHz)	(dBuV)	(dB)	(dB)	(dB)	(dBuV/m)	(dBuV/m)	(dB)	
5180MHz									
H	15540.0	56.59	30.55	5.77	24.66	56.47	74	-17.53	PK
H	15540.0	43.52	30.55	5.77	24.66	43.4	54	-10.6	AV
V	15540.0	57.49	30.33	6.32	24.55	58.03	74	-15.97	PK
V	15540.0	41.43	30.33	6.32	24.55	41.97	54	-12.03	AV
5200MHz									
H	15600.0	55.47	30.55	5.77	24.66	55.35	74	-18.65	PK
H	15600.0	44.17	30.55	5.77	24.66	44.05	54	-9.95	AV
V	15600.0	58.98	30.33	6.32	24.55	59.52	74	-14.48	PK
V	15600.0	42.46	30.33	6.32	24.55	43	54	-11	AV
5240MHz									
H	15720.0	56.7	30.55	5.77	24.66	56.58	74	-17.42	PK
H	15720.0	41.05	30.55	5.77	24.66	40.93	54	-13.07	AV
V	15720.0	57.72	30.33	6.32	24.55	58.26	74	-15.74	PK
V	15720.0	41.85	30.33	6.32	24.55	42.39	54	-11.61	AV

802.11n20

Polar (H/V)	Frequency	Meter Reading	Pre-amplifier	Cable Loss	Antenna Factor	Emission Level	Limits	Margin	Detect or Type
	(MHz)	(dBuV)	(dB)	(dB)	(dB)	(dBuV/m)	(dBuV/m)	(dB)	
5180MHz									
H	15540.0	59.31	30.55	5.77	24.66	59.19	74	-14.81	PK
H	15540.0	44.66	30.55	5.77	24.66	44.54	54	-9.46	AV
V	15540.0	55.99	30.33	6.32	24.55	56.53	74	-17.47	PK
V	15540.0	44.91	30.33	6.32	24.55	45.45	54	-8.55	AV
5200MHz									
H	15600.0	57.4	30.55	5.77	24.66	57.28	74	-16.72	PK
H	15600.0	44.56	30.55	5.77	24.66	44.44	54	-9.56	AV
V	15600.0	56.32	30.33	6.32	24.55	56.86	74	-17.14	PK
V	15600.0	44.81	30.33	6.32	24.55	45.35	54	-8.65	AV
5240MHz									
H	15720.0	57.08	30.55	5.77	24.66	56.96	74	-17.04	PK
H	15720.0	41.01	30.55	5.77	24.66	40.89	54	-13.11	AV
V	15720.0	57.01	30.33	6.32	24.55	57.55	74	-16.45	PK
V	15720.0	44.79	30.33	6.32	24.55	45.33	54	-8.67	AV



802.11ac20

Polar (H/V)	Frequency	Meter Reading	Pre-amplifier	Cable Loss	Antenna Factor	Emission Level	Limits	Margin	Detect or Type
	(MHz)	(dBuV)	(dB)	(dB)	(dB)	(dBuV/m)	(dBuV/m)	(dB)	
5180MHz									
H	15540.0	55.79	30.55	5.77	24.66	55.67	74	-18.33	PK
H	15540.0	42.62	30.55	5.77	24.66	42.5	54	-11.5	AV
V	15540.0	55.18	30.33	6.32	24.55	55.72	74	-18.28	PK
V	15540.0	44.16	30.33	6.32	24.55	44.7	54	-9.3	AV
5200MHz									
H	15600.0	57.06	30.55	5.77	24.66	56.94	74	-17.06	PK
H	15600.0	45	30.55	5.77	24.66	44.88	54	-9.12	AV
V	15600.0	57.08	30.33	6.32	24.55	57.62	74	-16.38	PK
V	15600.0	44.16	30.33	6.32	24.55	44.7	54	-9.3	AV
5240MHz									
H	15720.0	56.39	30.55	5.77	24.66	56.27	74	-17.73	PK
H	15720.0	41.23	30.55	5.77	24.66	41.11	54	-12.89	AV
V	15720.0	57.12	30.33	6.32	24.55	57.66	74	-16.34	PK
V	15720.0	41.59	30.33	6.32	24.55	42.13	54	-11.87	AV

802.11n40

Polar (H/V)	Frequency	Meter Reading	Pre-amplifier	Cable Loss	Antenna Factor	Emission Level	Limits	Margin	Detect or Type
	(MHz)	(dBuV)	(dB)	(dB)	(dB)	(dBuV/m)	(dBuV/m)	(dB)	
5190MHz									
H	15570.0	56.95	30.55	5.77	24.66	56.83	74	-17.17	PK
H	15570.0	43.82	30.55	5.77	24.66	43.7	54	-10.3	AV
V	15570.0	57.04	30.33	6.32	24.55	57.58	74	-16.42	PK
V	15570.0	44.95	30.33	6.32	24.55	45.49	54	-8.51	AV
5230MHz									
H	15690.0	57.96	30.55	5.77	24.66	57.84	74	-16.16	PK
H	15690.0	43.68	30.55	5.77	24.66	43.56	54	-10.44	AV
V	15690.0	57.18	30.33	6.32	24.55	57.72	74	-16.28	PK
V	15690.0	42.1	30.33	6.32	24.55	42.64	54	-11.36	AV

802.11ac40

Polar (H/V)	Frequency	Meter Reading	Pre-amplifier	Cable Loss	Antenna Factor	Emission Level	Limits	Margin	Detect or Type
	(MHz)	(dBuV)	(dB)	(dB)	(dB)	(dBuV/m)	(dBuV/m)	(dB)	
5190MHz									
H	15570.0	59.26	30.55	5.77	24.66	59.14	74	-14.86	PK
H	15570.0	41.92	30.55	5.77	24.66	41.8	54	-12.2	AV
V	15570.0	56.03	30.33	6.32	24.55	56.57	74	-17.43	PK
V	15570.0	41.82	30.33	6.32	24.55	42.36	54	-11.64	AV
5230MHz									
H	15690.0	59.5	30.55	5.77	24.66	59.38	74	-14.62	PK
H	15690.0	41.51	30.55	5.77	24.66	41.39	54	-12.61	AV
V	15690.0	57	30.33	6.32	24.55	57.54	74	-16.46	PK
V	15690.0	41.77	30.33	6.32	24.55	42.31	54	-11.69	AV



802.11ac80

Polar (H/V)	Frequency	Meter Reading	Pre-ampl ifier	Cable Loss	Antenna Factor	Emission Level	Limits	Margin	Detect or Type
	(MHz)	(dBuV)	(dB)	(dB)	(dB)	(dBuV/m)	(dBuV/ m)	(dB)	
5210MHz									
H	15630.0	55.01	30.55	5.77	24.66	54.89	74	-19.11	PK
H	15630.0	41.43	30.55	5.77	24.66	41.31	54	-12.69	AV
V	15630.0	56.17	30.33	6.32	24.55	56.71	74	-17.29	PK
V	15630.0	42.89	30.33	6.32	24.55	43.43	54	-10.57	AV

Remark:

1. Emission Level = Meter Reading + Antenna Factor + Cable Loss – Pre-amplifier,
Margin= Emission Level - Limit
2. If peak below the average limit, the average emission was no test.
3. The amplitude of spurious emissions which are attenuated by more than 20dB below the permissible value has no need to be reported.
4. All the modes have been tested and recorded worst mode in the report.



RADIATED Band EMISSION MEASUREMENT

	Polar (H/V)	Frequency (MHz)	Meter Reading (dBuV)	Pre-amplifier (dB)	Cable Loss (dB)	Antenna Factor (dB/m)	Emission level (dBuV/m)	Limit (dBuV/m)	Margin (dB)	Detector Type	Result
802.11a	Low Channel 5180MHz										
	H	5141.5	60.05	30.22	4.85	23.98	58.66	74.00	-15.34	PK	PASS
	H	5141.5	47.95	30.22	4.85	23.98	46.56	54.00	-7.44	AV	PASS
	H	5150	61.70	30.22	4.85	23.98	60.31	74.00	-13.69	PK	PASS
	H	5150	46.68	30.22	4.85	23.98	45.29	54.00	-8.71	AV	PASS
	V	5141.5	61.05	30.22	4.85	23.98	59.66	74.00	-14.34	PK	PASS
	V	5141.5	46.75	30.22	4.85	23.98	45.36	54.00	-8.64	AV	PASS
	V	5150	60.22	30.22	4.85	23.98	58.83	74.00	-15.17	PK	PASS
	V	5150	48.83	30.22	4.85	23.98	47.44	54.00	-6.56	AV	PASS
	High Channel 5240MHz										
	H	5350	61.00	30.22	4.85	23.98	59.61	74.00	-14.39	PK	PASS
	H	5350	48.98	30.22	4.85	23.98	47.59	54.00	-6.41	AV	PASS
	H	5410	62.54	30.22	4.85	23.98	61.15	74.00	-12.85	PK	PASS
	H	5410	47.40	30.22	4.85	23.98	46.01	54.00	-7.99	AV	PASS
	V	5350	61.64	30.22	4.85	23.98	60.25	74.00	-13.75	PK	PASS
	V	5350	47.49	30.22	4.85	23.98	46.10	54.00	-7.90	AV	PASS
V	5410	59.28	30.22	4.85	23.98	57.89	74.00	-16.11	PK	PASS	
V	5410	47.30	30.22	4.85	23.98	45.91	54.00	-8.09	AV	PASS	
802.11n20	Low Channel 5180MHz										
	H	5141.5	62.01	30.22	4.85	23.98	60.62	74.00	-13.38	PK	PASS
	H	5141.5	46.41	30.22	4.85	23.98	45.02	54.00	-8.98	AV	PASS
	H	5150	59.29	30.22	4.85	23.98	57.90	74.00	-16.10	PK	PASS
	H	5150	46.39	30.22	4.85	23.98	45.00	54.00	-9.00	AV	PASS
	V	5141.5	61.91	30.22	4.85	23.98	60.52	74.00	-13.48	PK	PASS
	V	5141.5	46.61	30.22	4.85	23.98	45.22	54.00	-8.78	AV	PASS
	V	5150	59.78	30.22	4.85	23.98	58.39	74.00	-15.61	PK	PASS
	V	5150	48.62	30.22	4.85	23.98	47.23	54.00	-6.77	AV	PASS
	High Channel 5240MHz										
	H	5350	59.31	30.22	4.85	23.98	57.92	74.00	-16.08	PK	PASS
	H	5350	46.24	30.22	4.85	23.98	44.85	54.00	-9.15	AV	PASS
	H	5410	60.73	30.22	4.85	23.98	59.34	74.00	-14.66	PK	PASS
	H	5410	47.98	30.22	4.85	23.98	46.59	54.00	-7.41	AV	PASS
	V	5350	61.81	30.22	4.85	23.98	60.42	74.00	-13.58	PK	PASS
	V	5350	47.35	30.22	4.85	23.98	45.96	54.00	-8.04	AV	PASS
V	5410	61.09	30.22	4.85	23.98	59.70	74.00	-14.30	PK	PASS	
V	5410	48.99	30.22	4.85	23.98	47.60	54.00	-6.40	AV	PASS	



	Polar (H/V)	Frequency (MHz)	Meter Reading (dBuV)	Pre-amplifier (dB)	Cable Loss (dB)	Antenna Factor (dB/m)	Emission level (dBuV/m)	Limit (dBuV/m)	Margin (dB)	Detector Type	Result
802.11 n40	Low Channel 5190MHz										
	H	5148.8	62.68	30.22	4.85	23.98	61.29	74.00	-12.71	PK	PASS
	H	5148.8	46.78	30.22	4.85	23.98	45.39	54.00	-8.61	AV	PASS
	H	5150	62.90	30.22	4.85	23.98	61.51	74.00	-12.49	PK	PASS
	H	5150	47.35	30.22	4.85	23.98	45.96	54.00	-8.04	AV	PASS
	V	5148.8	60.13	30.22	4.85	23.98	58.74	74.00	-15.26	PK	PASS
	V	5148.8	48.31	30.22	4.85	23.98	46.92	54.00	-7.08	AV	PASS
	V	5150	59.76	30.22	4.85	23.98	58.37	74.00	-15.63	PK	PASS
	V	5150	48.44	30.22	4.85	23.98	47.05	54.00	-6.95	AV	PASS
	High Channel 5230MHz										
	H	5350.0	62.72	30.22	4.85	23.98	61.33	74.00	-12.67	PK	PASS
	H	5350.0	48.81	30.22	4.85	23.98	47.42	54.00	-6.58	AV	PASS
	H	5353.4	61.02	30.22	4.85	23.98	59.63	74.00	-14.37	PK	PASS
	H	5353.4	46.74	30.22	4.85	23.98	45.35	54.00	-8.65	AV	PASS
	V	5350.0	61.72	30.22	4.85	23.98	60.33	74.00	-13.67	PK	PASS
	V	5350.0	47.85	30.22	4.85	23.98	46.46	54.00	-7.54	AV	PASS
V	5353.4	60.21	30.22	4.85	23.98	58.82	74.00	-15.18	PK	PASS	
V	5353.4	47.16	30.22	4.85	23.98	45.77	54.00	-8.23	AV	PASS	
802.11 ac20	Low Channel 5180MHz										
	H	5141.5	60.77	30.22	4.85	23.98	59.38	74.00	-14.62	PK	PASS
	H	5141.5	48.04	30.22	4.85	23.98	46.65	54.00	-7.35	AV	PASS
	H	5150	59.20	30.22	4.85	23.98	57.81	74.00	-16.19	PK	PASS
	H	5150	48.40	30.22	4.85	23.98	47.01	54.00	-6.99	AV	PASS
	V	5141.5	62.72	30.22	4.85	23.98	61.33	74.00	-12.67	PK	PASS
	V	5141.5	46.75	30.22	4.85	23.98	45.36	54.00	-8.64	AV	PASS
	V	5150	61.57	30.22	4.85	23.98	60.18	74.00	-13.82	PK	PASS
	V	5150	46.25	30.22	4.85	23.98	44.86	54.00	-9.14	AV	PASS
	High Channel 5240MHz										
	H	5350	60.98	30.22	4.85	23.98	59.59	74.00	-14.41	PK	PASS
	H	5350	46.16	30.22	4.85	23.98	44.77	54.00	-9.23	AV	PASS
	H	5410	60.58	30.22	4.85	23.98	59.19	74.00	-14.81	PK	PASS
	H	5410	48.16	30.22	4.85	23.98	46.77	54.00	-7.23	AV	PASS
	V	5350	62.24	30.22	4.85	23.98	60.85	74.00	-13.15	PK	PASS
	V	5350	48.44	30.22	4.85	23.98	47.05	54.00	-6.95	AV	PASS
V	5410	61.83	30.22	4.85	23.98	60.44	74.00	-13.56	PK	PASS	
V	5410	48.34	30.22	4.85	23.98	46.95	54.00	-7.05	AV	PASS	



	Polar (H/V)	Frequency (MHz)	Meter Reading (dBuV)	Pre-amplifier (dB)	Cable Loss (dB)	Antenna Factor (dB/m)	Emission level (dBuV/m)	Limit (dBuV/m)	Margin(dB)	Detector Type	Result
802.11 ac40	Low Channel 5190MHz										
	H	5148.8	62.56	30.22	4.85	23.98	61.17	74.00	-12.83	PK	PASS
	H	5148.8	47.46	30.22	4.85	23.98	46.07	54.00	-7.93	AV	PASS
	H	5150	59.50	30.22	4.85	23.98	58.11	74.00	-15.89	PK	PASS
	H	5150	46.47	30.22	4.85	23.98	45.08	54.00	-8.92	AV	PASS
	V	5148.8	59.38	30.22	4.85	23.98	57.99	74.00	-16.01	PK	PASS
	V	5148.8	46.54	30.22	4.85	23.98	45.15	54.00	-8.85	AV	PASS
	V	5150	61.51	30.22	4.85	23.98	60.12	74.00	-13.88	PK	PASS
	V	5150	46.02	30.22	4.85	23.98	44.63	54.00	-9.37	AV	PASS
	High Channel 5230MHz										
	H	5350.0	60.66	30.22	4.85	23.98	59.27	74.00	-14.73	PK	PASS
	H	5350.0	48.59	30.22	4.85	23.98	47.20	54.00	-6.80	AV	PASS
	H	5353.4	62.60	30.22	4.85	23.98	61.21	74.00	-12.79	PK	PASS
	H	5353.4	48.57	30.22	4.85	23.98	47.18	54.00	-6.82	AV	PASS
	V	5350.0	59.17	30.22	4.85	23.98	57.78	74.00	-16.22	PK	PASS
	V	5350.0	48.48	30.22	4.85	23.98	47.09	54.00	-6.91	AV	PASS
V	5353.4	62.36	30.22	4.85	23.98	60.97	74.00	-13.03	PK	PASS	
V	5353.4	48.35	30.22	4.85	23.98	46.96	54.00	-7.04	AV	PASS	
	Polar (H/V)	Frequency (MHz)	Meter Reading (dBuV)	Pre-amplifier (dB)	Cable Loss (dB)	Antenna Factor (dB/m)	Emission level (dBuV/m)	Limit (dBuV/m)	Margin(dB)	Detector Type	Result
802.11 ac80	5210MHz										
	H	5123.0	61.20	30.22	4.85	23.98	59.81	74.00	-14.19	PK	PASS
	H	5123.0	48.71	30.22	4.85	23.98	47.32	54.00	-6.68	AV	PASS
	H	5150.0	60.16	30.22	4.85	23.98	58.77	74.00	-15.23	PK	PASS
	H	5150.0	46.83	30.22	4.85	23.98	45.44	54.00	-8.56	AV	PASS
	V	5150.0	60.32	30.22	4.85	23.98	58.93	74.00	-15.07	PK	PASS
	V	5150.0	47.10	30.22	4.85	23.98	45.71	54.00	-8.29	AV	PASS
	V	5150.0	60.23	30.22	4.85	23.98	58.84	74.00	-15.16	PK	PASS
V	5150.0	46.83	30.22	4.85	23.98	45.44	54.00	-8.56	AV	PASS	



5. POWER SPECTRAL DENSITY TEST

5.1 APPLIED PROCEDURES / LIMIT

According to FCC §15.407(a)

Power limits:

(1) For the band 5.15-5.25 GHz.

(i) For an outdoor access point operating in the band 5.15-5.25 GHz, the maximum power spectral density shall not exceed 17 dBm in any 1 megahertz band. If transmitting antennas of directional gain greater than 6 dBi are used, both the maximum conducted output power and the maximum power spectral density shall be reduced by the amount in dB that the directional gain of the antenna exceeds 6 dBi. The maximum e.i.r.p. at any elevation angle above 30 degrees as measured from the horizon must not exceed 125 mW (21 dBm).

(ii) For an indoor access point operating in the band 5.15-5.25 GHz, the maximum power spectral density shall not exceed 17 dBm in any 1 megahertz band. If transmitting antennas of directional gain greater than 6 dBi are used, both the maximum conducted output power and the maximum power spectral density shall be reduced by the amount in dB that the directional gain of the antenna exceeds 6 dBi.

(iii) For fixed point-to-point access points operating in the band 5.15-5.25 GHz, the maximum power spectral density shall not exceed 17 dBm in any 1 megahertz band. Fixed point-to-point U-NII devices may employ antennas with directional gain up to 23 dBi without any corresponding reduction in the maximum conducted output power or maximum power spectral density. For fixed point-to-point transmitters that employ a directional antenna gain greater than 23 dBi, a 1 dB reduction in maximum conducted output power and maximum power spectral density is required for each 1 dB of antenna gain in excess of 23 dBi. Fixed, point-to-point operations exclude the use of point-to-multipoint systems, omnidirectional applications, and multiple collocated transmitters transmitting the same information. The operator of the U-NII device, or if the equipment is professionally installed, the installer, is responsible for ensuring that systems employing high gain directional antennas are used exclusively for fixed, point-to-point operations.

(iv) For client devices in the 5.15-5.25 GHz band, the maximum power spectral density shall not exceed 11 dBm in any 1 megahertz band. If transmitting antennas of directional gain greater than 6 dBi are used, both the maximum conducted output power and the maximum power spectral density shall be reduced by the amount in dB that the directional gain of the antenna exceeds 6 dBi.



5.2 TEST PROCEDURE

For devices operating in the bands 5.15-5.25 GHz, 5.25-5.35 GHz, and 5.47-5.725 GHz, the above procedures make use of 1 MHz RBW to satisfy directly the 1 MHz reference bandwidth specified in § 15.407(a)(5). For devices operating in the band 5.725-5.85 GHz, the rules specify a measurement bandwidth of 500 kHz. Many spectrum analyzers do not have 500 kHz RBW, thus a narrower RBW may need to be used. The rules permit the use of a RBWs less than 1 MHz, or 500 kHz, “provided that the measured power is integrated over the full reference bandwidth” to show the total power over the specified measurement bandwidth (i.e., 1 MHz, or 500 kHz). If measurements are performed using a reduced resolution bandwidth (< 1 MHz, or <500 kHz) and integrated over 1 MHz, or 500 KHz bandwidth, the following adjustments to the procedures apply:

- a) Set $RBW \geq 1/T$, where T is defined in section II.B.I.a).
- b) Set $VBW \geq 3 RBW$.
- c) If measurement bandwidth of Maximum PSD is specified in 500 kHz, add $10\log(500\text{kHz}/RBW)$ to the measured result, whereas $RBW (< 500 \text{ KHz})$ is the reduced resolution bandwidth of the spectrum analyzer set during measurement.
- d) If measurement bandwidth of Maximum PSD is specified in 1 MHz, add $10\log(1\text{MHz}/RBW)$ to the measured result, whereas $RBW (< 1 \text{ MHz})$ is the reduced resolution bandwidth of spectrum analyzer set during measurement.
- e) Care must be taken to ensure that the measurements are performed during a period of continuous transmission or are corrected upward for duty cycle.

Note: As a practical matter, it is recommended to use reduced RBW of 100 KHz for the sections 5.c) and 5.d) above, since $RBW=100 \text{ KHZ}$ is available on nearly all spectrum analyzers.

5.3 DEVIATION FROM STANDARD

No deviation.

5.4 TEST SETUP



5.5 EUT OPERATION CONDITIONS

The EUT tested system was configured as the statements of 2.1 Unless otherwise a special operating condition is specified in the follows during the testing.



5.6 TEST RESULTS

Temperature :	24.2°C	Relative Humidity:	53%
Pressure :	1010 hPa	Test Voltage :	AC 120V/60Hz
Test Mode :	TX		
Test result:	Please refer to the Appendix A.5 for 5G WIFI RF Test Data.		



6. 26DB & 6DB &99% EMISSION BANDWIDTH

6.1 APPLIED PROCEDURES / LIMIT

The maximum power spectral density is measured as a conducted emission by direct connection of a calibrated test instrument to the equipment under test. If the device cannot be connected directly, alternative techniques acceptable to the Commission may be used. Measurements in the 5.725-5.85 GHz band, the minimum bandwidth 6 dB bandwidth of U-NII devices shall be at least 500KHz. Measurements in the 5.15-5.25 GHz, 5.25-5.35 GHz, and the 5.47-5.725 GHz bands are made over a bandwidth of 1 MHz or the 26 dB emission bandwidth of the device, whichever is less. A narrower resolution bandwidth can be used, provided that the measured power is integrated over the full reference bandwidth.

6.2 TEST PROCEDURE

- a) Set RBW = 1 % to 5 % of the OBW .
- b) Set the VBW = 3 · RBW
- c) Detector = Peak.
- d) Trace mode = max hold.
- e) Measure the maximum width of the emission that is constrained by the frequencies associated with the two outermost amplitude points (upper and lower frequencies) that are attenuated by -26 dB relative to the maximum level measured in the fundamental emission.

The following procedure shall be used for measuring (99 %) power bandwidth:

1. Set center frequency to the nominal EUT channel center frequency.
2. Set span = 1.5 times to 5.0 times the OBW.
3. Set RBW = 1 % to 5 % of the OBW
4. Set VBW $\geq 3 \cdot$ RBW
5. Video averaging is not permitted. Where practical, a sample detection and single sweep mode shall be used. Otherwise, peak detection and max hold mode (until the trace stabilizes) shall be used.
6. Use the 99 % power bandwidth function of the instrument (if available).
7. If the instrument does not have a 99 % power bandwidth function, the trace data points are recovered and directly summed in power units. The recovered amplitude data points, beginning at the lowest frequency, are placed in a running sum until 0.5 % of the total is reached; that frequency is recorded as the lower frequency. The process is repeated until 99.5 % of the total is reached; that frequency is recorded as the upper frequency. The 99% occupied bandwidth is the difference between these two frequencies.





6.3 EUT OPERATION CONDITIONS

The EUT tested system was configured as the statements of 2.4 Unless otherwise a special operating condition is specified in the follows during the testing.

6.4 TEST RESULTS

Temperature :	24.2°C	Relative Humidity:	53%
Pressure :	1010 hPa	Test Voltage :	AC 120V/60Hz
Test Mode :	TX		
Test result:	-26dB Bandwidth	Please refer to the Appendix A.3 for 5G WIFI RF Test Data.	
	99% Bandwidth	Please refer to the Appendix A.4 for 5G WIFI RF Test Data.	



7. MAXIMUM CONDUCTED OUTPUT POWER

7.1 PLIED PROCEDURES / LIMIT

According to FCC §15.407,
The maximum conducted output power should not exceed:

Frequency Band(MHz)	Limit
5150~5250	250mW
5725~5850	1W

For an outdoor access point operating in the band 5.15-5.25 GHz, the maximum conducted output power over the frequency band of operation shall not exceed 1 W provided the maximum antenna gain does not exceed 6 dBi.

If transmitting antennas of directional gain greater than 6 dBi are used, the maximum conducted output power shall be reduced by the amount in dB that the directional gain of the antenna exceeds 6 dBi. The maximum e.i.r.p. at any elevation angle above 30 degrees as measured from the horizon must not exceed 125 mW (21 dBm).

For an indoor access point operating in the band 5.15-5.25 GHz, the maximum conducted output power over the frequency band of operation shall not exceed 1 W provided the maximum antenna gain does not exceed 6 dBi.

If transmitting antennas of directional gain greater than 6 dBi are used, the maximum conducted output power shall be reduced by the amount in dB that the directional gain of the antenna exceeds 6 dBi.

For fixed point-to-point access points operating in the band 5.15-5.25 GHz, the maximum conducted output power over the frequency band of operation shall not exceed 1 W.

Fixed point-to-point U-NII devices may employ antennas with directional gain up to 23 dBi without any corresponding reduction in the maximum conducted output power.

For fixed point-to-point transmitters that employ a directional antenna gain greater than 23 dBi, a 1 dB reduction in maximum conducted output power is required for each 1 dB of antenna gain in excess of 23 dBi. Fixed, point-to-point operations exclude the use of point-to-multipoint systems, omnidirectional applications, and multiple collocated transmitters transmitting the same information. The operator of the U-NII device, or if the equipment is professionally installed, the installer, is responsible for ensuring that systems employing high gain directional antennas are used exclusively for fixed, point-to-point operations.

For client devices in the 5.15-5.25 GHz band, the maximum conducted output power over the frequency band of operation shall not exceed 250 mW provided the maximum antenna gain does not exceed 6 dBi.

If transmitting antennas of directional gain greater than 6 dBi are used, the maximum conducted output power shall be reduced by the amount in dB that the directional gain of the antenna exceeds 6 dBi.

For the 5.25-5.35 GHz and 5.47-5.725 GHz bands, the maximum conducted output power over the frequency bands of operation shall not exceed the lesser of 250 mW or 11 dBm + 10 log B, where B is the 26 dB emission bandwidth in megahertz.

If transmitting antennas of directional gain greater than 6 dBi are used, the maximum conducted output power shall be reduced by the amount in dB that the directional gain of the antenna exceeds 6 dBi.

For the band 5.725-5.850 GHz, the maximum conducted output power over the frequency band of operation shall not exceed 1 W.

If transmitting antennas of directional gain greater than 6 dBi are used, the maximum conducted output power shall be reduced by the amount in dB that the directional gain of the antenna exceeds 6 dBi.

However, fixed point-to-point U-NII devices operating in this band may employ transmitting antennas with directional gain greater than 6 dBi without any corresponding reduction in transmitter conducted power. Fixed, point-to-point operations exclude the use of point-to-multipoint systems, omnidirectional applications, and multiple collocated transmitters transmitting the same information. The operator of the U-NII device, or if the equipment is professionally installed, the installer, is responsible for ensuring that systems employing high gain directional antennas are used exclusively for fixed, point-to-point operations.



7.2 TEST PROCEDURE

The EUT was directly connected to the Spectrum Analyzer

1. Device Configuration

If possible, configure or modify the operation of the EUT so that it transmits continuously at its maximum power control level (see section II.B.).

a) The intent is to test at 100 percent duty cycle; however a small reduction in duty cycle (to no lower than 98 percent) is permitted if required by the EUT for amplitude control purposes. Manufacturers are expected to provide software to the test lab to permit such continuous operation.

b) If continuous transmission (or at least 98 percent duty cycle) cannot be achieved due to hardware limitations (e.g., overheating), the EUT shall be operated at its maximum power control level with the transmit duration as long as possible and the duty cycle as high as possible.

2. Measurement using a Spectrum Analyzer or EMI Receiver (SA)

Measurement of maximum conducted output power using a spectrum analyzer requires integrating the spectrum across a frequency span that encompasses, at a minimum, either the EBW or the 99-percent occupied bandwidth of the signal.¹ However, the EBW must be used to determine bandwidth dependent limits on maximum conducted output power in accordance with § 15.407(a).

a) The test method shall be selected as follows: (i) Method SA-1 or SA-1 Alternative (averaging with the EUT transmitting at full power throughout each sweep) shall be applied if either of the following conditions can be satisfied:

- The EUT transmits continuously (or with a duty cycle ≥ 98 percent).
- Sweep triggering or gating can be implemented in a way that the device transmits at the maximum power control level throughout the duration of each of the instrument sweeps to be averaged. This condition can generally be achieved by triggering the instrument's sweep if the duration of the sweep (with the analyzer configured as in Method SA-1, below) is equal to or shorter than the duration T of each transmission from the EUT and if those transmissions exhibit full power throughout their durations.

(ii) Method SA-2 or SA-2 Alternative (averaging across on and off times of the EUT transmissions, followed by duty cycle correction) shall be applied if the conditions of (i) cannot be achieved and the transmissions exhibit a constant duty cycle during the measurement duration. Duty cycle will be considered to be constant if variations are less than ± 2 percent.

(iii) Method SA-3 (RMS detection with max hold) or SA-3 Alternative (reduced VBW with max hold) shall be applied if the conditions of (i) and (ii) cannot be achieved.

b) Method SA-1 (trace averaging with the EUT transmitting at full power throughout each sweep): (i) Set span to encompass the entire emission bandwidth (EBW) (or, alternatively, the entire 99% occupied bandwidth) of the signal.

(ii) Set RBW = 1 MHz.

(iii) Set VBW ≥ 3 MHz.

(iv) Number of points in sweep ≥ 2 Span / RBW. (This ensures that bin-to-bin spacing is \leq RBW/2, so that narrowband signals are not lost between frequency bins.)

(v) Sweep time = auto.

(vi) Detector = RMS (i.e., power averaging), if available. Otherwise, use sample detector mode.

(vii) If transmit duty cycle < 98 percent, use a video trigger with the trigger level set to enable triggering only on full power pulses. Transmitter must operate at maximum power control level for the entire duration of every sweep. If the EUT transmits continuously (i.e., with no off intervals) or at duty cycle ≥ 98 percent, and if each transmission is entirely at the maximum power control level, then the trigger shall be set to "free run".

(viii) Trace average at least 100 traces in power averaging (i.e., RMS) mode.

(ix) Compute power by integrating the spectrum across the EBW (or, alternatively, the entire 99% occupied bandwidth) of the signal using the instrument's band power measurement function with band limits set equal to the EBW (or occupied bandwidth) band edges. If the instrument does not have a band power function, sum the spectrum

7.3 DEVIATION FROM STANDARD

No deviation.



7.4 TEST SETUP

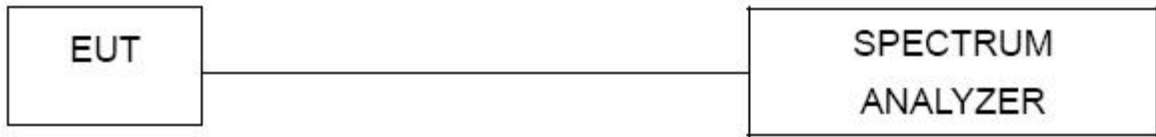

7.5 EUT OPERATION CONDITIONS

The EUT tested system was configured as the statements of 2.4 Unless otherwise a special operating condition is specified in the follows during the testing.

7.6 TEST RESULTS

Temperature :	24.2°C	Relative Humidity:	53%
Pressure :	1010 hPa	Test Voltage :	AC 120V/60Hz
Test Mode :	TX		
Test result:	Please refer to the Appendix A.2 for 5G WIFI RF Test Data.		



8. OUT OF BAND EMISSIONS

8.1 APPLICABLE STANDARD

According to FCC §15.407(b), RSS-247 6.2.1.2, RSS-247 6.2.4.2

Undesirable emission limits. Except as shown in paragraph (b)(7) of this section, the maximum emissions outside of the frequency bands of operation shall be attenuated in accordance with the following limits:

(1) For transmitters operating in the 5.15-5.25 GHz band: All emissions outside of the 5.15-5.35 GHz band shall not exceed an e.i.r.p. of -27 dBm/MHz.

(2) Devices operating in the band 5725-5850 MHz shall have e.i.r.p. of unwanted emissions comply with the following:

All emissions shall be limited to a level of -27 dBm/MHz at 75 MHz or more above or below the band edge increasing linearly to 10 dBm/MHz at 25 MHz above or below the band edge, and from 25 MHz above or below the band edge increasing linearly to a level of 15.6 dBm/MHz at 5 MHz above or below the band edge, and from 5 MHz above or below the band edge increasing linearly to a level of 27 dBm/MHz at the band edge.

According to RSS-247 section 6.2.1.2: For transmitters with operating frequencies in the band 5150-5250 MHz, all emissions outside the band 5150-5350 MHz shall not exceed -27 dBm/MHz e.i.r.p. Any unwanted emissions that fall into the band 5250-5350 MHz shall be attenuated below the channel power by at least 26 dB, when measured using a resolution bandwidth between 1 and 5% of the occupied bandwidth (i.e. 99% bandwidth), above 5250 MHz. The 26 dB bandwidth may fall into the 5250-5350 MHz band; however, if the occupied bandwidth also falls within the 5250-5350 MHz band, the transmission is considered as intentional and the devices shall comply with all requirements in the band 5250-5350 MHz including implementing dynamic frequency selection (DFS) and TPC, on the portion of the emission that resides in the 5250- 5350 MHz band.



8.2 TEST PROCEDURE

1. Check the calibration of the measuring instrument using either an internal calibrator or a known signal from an external generator.
2. Position the EUT without connection to measurement instrument. Turn on the EUT and connect its antenna terminal to measurement instrument via a low loss cable. Then set it to any one measured frequency within its operating range, and make sure the instrument is operated in its linear range.
3. Set RBW of spectrum analyzer to 1 MHz with a convenient frequency span.
4. Measure the highest amplitude appearing on spectral display and set it as a reference level. Plot the graph with marking the highest point and edge frequency.
5. Repeat above procedures until all measured frequencies were complete.

8.3 DEVIATION FROM STANDARD

No deviation.

8.4 TEST SETUP



8.5 EUT OPERATION CONDITIONS

The EUT tested system was configured as the statements of 2.4 Unless otherwise a special operating condition is specified in the follows during the testing.

8.6 TEST RESULTS

Temperature :	24.2℃	Relative Humidity:	53%
Pressure :	1010 hPa	Test Voltage :	AC 120V/60Hz
Test Mode :	TX		
Test result:	Please refer to the Appendix A.6 for 5G WIFI RF Test Data.		



9.SPURIOUS RF CONDUCTED EMISSIONS

9.1 CONFORMANCE LIMIT

Refer to 15.407(b):

Except as shown in paragraph 15.407(b)(7) of this section, the maximum emissions outside of the frequency bands of operation shall be attenuated in accordance with the following limits:

For transmitters operating in the 5.15-5.25 GHz band: All emissions outside of the 5.15-5.35 GHz band shall not exceed an e.i.r.p. of -27 dBm/MHz.

Refer to RSS-247/6.2.1.2:

For transmitters with operating frequencies in the band 5150-5250 MHz, all emissions outside the band 5150-5350 MHz shall not exceed -27 dBm/MHz e.i.r.p. Any unwanted emissions that fall into the band 5250-5350 MHz shall be attenuated below the channel power by at least 26 dB, when measured using a resolution bandwidth between 1 and 5% of the occupied bandwidth (i.e. 99% bandwidth), above 5250 MHz. The 26 dB bandwidth may fall into the 5250-5350 MHz band; however, if the occupied bandwidth also falls within the 5250-5350 MHz band, the transmission is considered as intentional and the devices shall comply with all requirements in the band 5250-5350 MHz including implementing dynamic frequency selection (DFS) and TPC, on the portion of the emission that resides in the 5250-5350 MHz band.

Devices operating in the band 5725-5850 MHz shall have e.i.r.p. of unwanted emissions comply with the following:

- 27 dBm/MHz at frequencies from the band edges decreasing linearly to 15.6 dBm/MHz at 5 MHz above or below the band edges;
- 15.6 dBm/MHz at 5 MHz above or below the band edges decreasing linearly to 10 dBm/MHz at 25 MHz above or below the band edges;
- 10 dBm/MHz at 25 MHz above or below the band edges decreasing linearly to -27 dBm/MHz at 75 MHz above or below the band edges; and
- 27 dBm/MHz at frequencies more than 75 MHz above or below the band edges.

9.2 Measuring Instruments

The Measuring equipment is listed in the section 6.3 of this test report.

9.3 TEST SETUP



9.4 TEST PROCEDURE

The Spurious RF conducted emissions compliance of RF radiated emission should be measured by following the guidance in ANSI C63.10-2013 with respect to maximizing the emission by rotating the EUT, measuring the emission while the EUT is situated in three orthogonal planes (if appropriate), adjusting the measurement antenna height and polarization etc. Set RBW=100kHz and VBW= 300KHz to measure the peak field strength, and measure frequency range from 30MHz to 1GHz. Set RBW=1MHz and VBW= 3MHz to measure the peak field strength, and measure frequency range from 1GHz to 40GHz.



9.5 TEST RESULTS

Temperature :	24.2°C	Relative Humidity:	53%
Pressure :	1010 hPa	Test Voltage :	AC 120V/60Hz
Test Mode :	TX		
Test result:	Please refer to the Appendix A.8 for 5G WIFI RF Test Data.		

Remark1: The measurement frequency range is from 30MHz to the 10th harmonic or 40G of the fundamental frequency. The lowest, middle and highest channels are tested to verify the spurious emissions and bandedge measurement data.

Remark2: 26.5G to 40G is the background, so it does not show the data.



10.FREQUENCY STABILITY MEASUREMENT

10.1 LIMIT

Manufactures of U-NII devices are responsible for ensuring frequency stability such that an emission is maintained within the band of operation under all conditions of normal operation as specified in the user's manual.

According to RSS-247 "Manufacturers of U-NII devices are responsible for ensuring frequency stability such that an emission is maintained within the band of operation under all conditions of normal operation as specified in the users manual." According to RSS-Gen "The frequency stability shall be measured with variation of ambient temperature as follows:" (1) From -30° to $+50^{\circ}$ centigrade for all equipment except that specified in paragraphs (a) (2) and (3) of this section. (2) From -20° to $+50^{\circ}$ centigrade for equipment to be licensed for use in the Maritime Services under part 80 of this chapter, except for Class A, B, and S Emergency Position Indicating Radiobeacons (EPIRBS), and equipment to be licensed for use above 952 MHz at operational fixed stations in all services, stations in the Local Television Transmission Service and Point-to-Point Microwave Radio Service under part 21 of this chapter, equipment licensed for use aboard aircraft in the Aviation Services under part 87 of this chapter, and equipment authorized for use in the Family Radio Service under part 95 of this chapter. (3) From 0° to $+50^{\circ}$ centigrade for equipment to be licensed for use in the Radio Broadcast Services under part 73 of this chapter.

10.2 TEST PROCEDURES

1. The transmitter output (antenna port) was connected to the spectrum analyzer.
2. EUT have transmitted absence of modulation signal and fixed channelize.
3. Set the spectrum analyzer span to view the entire absence of modulation emissions bandwidth.
4. Set RBW = 10 kHz, VBW = 30 kHz with peak detector and maxhold settings.
5. The test extreme voltage is to change the primary supply voltage from 85 to 115 percent of the nominal value
6. Extreme temperature is $-20^{\circ}\text{C}\sim 60^{\circ}\text{C}$.

10.3 TEST SETUP LAYOUT





10.4 EUT OPERATION DURING TEST

The EUT was programmed to be in continuously un-modulation transmitting mode.

10.5 TEST RESULTS

Temperature :	24.2℃	Relative Humidity:	53%
Pressure :	1010 hPa	Test Voltage :	AC 120V/60Hz
Test Mode :	TX		
Test result:	Please refer to the Appendix A.7 for 5G WIFI RF Test Data.		



11. CHANNEL MOVE TIME, CHANNEL CLOSING TRANSMISSION TIME

11.1 LIMIT

Channel Move Time: within 10 seconds

Channel Closing Transmission Time: 200 milliseconds + an aggregate of 60 milliseconds over remaining 10 second period. (The Channel Closing Transmission Time is comprised of 200 milliseconds starting at the beginning of the Channel Move Time plus any additional intermittent control signals required to facilitate a Channel move (an aggregate of 60 milliseconds) during the remainder of the 10 second period. The aggregate duration of control signals will not count quiet periods in between transmissions.)

11.2 TEST SETUP LAYOUT

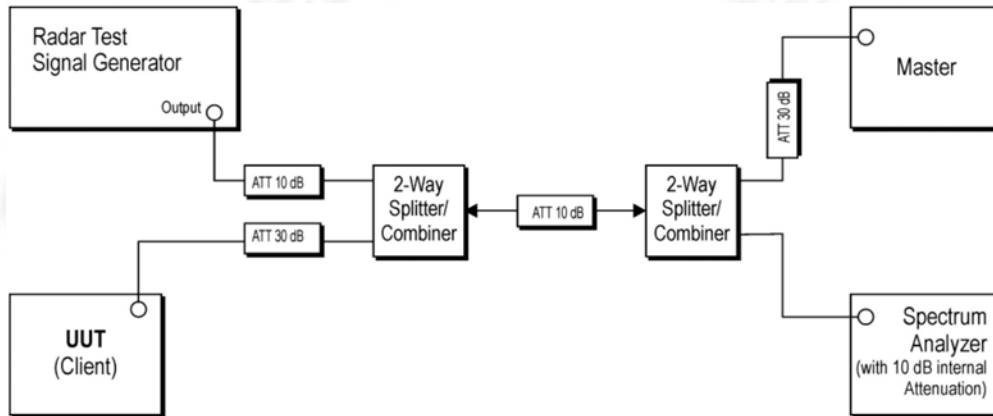

11.3 TEST PROCEDURE

1. When a Client Device without Radar Detection is the UUT, the Master Device is the Radar Detection Device.
2. A spectrum analyzer is used to establish the test signal level for each radar type.
3. During this process, there are no transmissions by either the Master Device or Client Device.
4. The spectrum analyzer is switched to the zero span (time domain) mode at the frequency of the Radar Waveform generator. The peak detector function of the spectrum analyzer is utilized. The spectrum analyzer resolution bandwidth (RBW) and video bandwidth (VBW) are set to at least 3 MHz.
5. The measured channels are 5300MHz in 20MHz Bandwidth. The Radar signal was the same as transmitted channels, and injected into the antenna port of AP(master), measured the DFS parameters. The master transmitted the test data to client, the transmitted duty cycle is 35%.

11.4 TEST RESULTS

N/A



12. NON-OCCUPANCY PERIOD TEST

12.1 LIMIT

A channel that has been flagged as containing a radar system, either by a channel availability check or in-service monitoring, is subject to a non-occupancy period of at least 30 minutes. The non-occupancy period starts at the time when the radar system is detected.

12.2 TEST SETUP LAYOUT

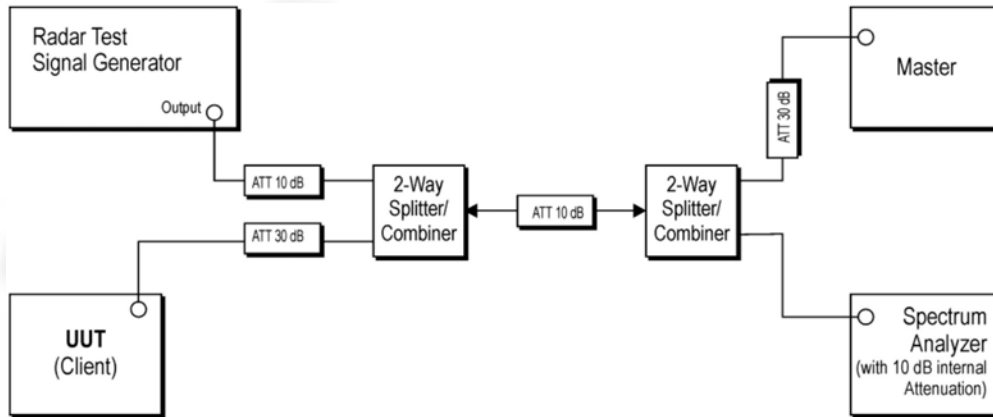

12.3 TEST RESULTS

N/A



13. DFS DETECTION THRESHOLDS

13.1 LIMIT

DFS Detection Thresholds for Master Devices and Client Devices With Radar Detection

Maximum Transmit Power	Value (See Notes 1, 2, and 3)
EIRP \geq 200 milliwatt	-64 dBm
EIRP < 200 milliwatt and power spectral density < 10 dBm/MHz	-62 dBm
EIRP < 200 milliwatt that do not meet the power spectral density requirement	-64 dBm

Note 1: This is the level at the input of the receiver assuming a 0 dBi receive antenna.

Note 2: Throughout these test procedures an additional 1 dB has been added to the amplitude of the test transmission waveforms to account for variations in measurement equipment. This will ensure that the test signal is at or above the detection threshold level to trigger a DFS response.

Note3: EIRP is based on the highest antenna gain. For MIMO devices refer to KDB Publication 662911 D01.

13.2 TEST SETUP LAYOUT

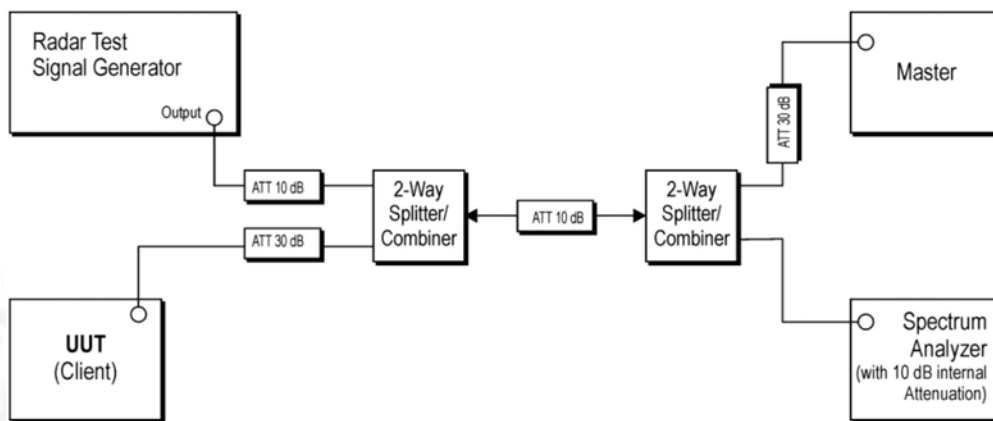

13.3 TEST RESULTS

N/A



14. ANTENNA REQUIREMENT

Standard requirement:	FCC Part15 C Section 15.203, RSS-247 6.8
<p>15.203 requirement: An intentional radiator shall be designed to ensure that no antenna other than that furnished by the responsible party shall be used with the device. The use of a permanently attached antenna or of an antenna that uses a unique coupling to the intentional radiator, the manufacturer may design the unit so that a broken antenna can be replaced by the user, but the use of a standard antenna jack or electrical connector is prohibited.</p> <p>The applicant for equipment certification, as per RSP-100, must provide a list of all antenna types that may be used with the licence-exempt transmitter, indicating the maximum permissible antenna gain (in dBi) and the required impedance for each antenna. Licence-exempt transmitters that have received equipment certification may operate with different types of antennas. However, it is not permissible to exceed the maximum equivalent isotropically radiated power (EIRP) limits specified in the applicable standard (RSS) for the licence-exempt apparatus. Testing shall be performed using the highest gain antenna of each combination of licence-exempt transmitter and antenna type, with the transmitter output power set at the maximum level.⁹ When a measurement at the antenna connector is used to determine RF output power, the effective gain of the device's antenna shall be stated, based on a measurement or on data from the antenna manufacturer.</p>	
EUT Antenna:	
The antenna is PCB Antenna, the best case gain of the antenna is 3.48dBii, reference to the appendix II for details	



15. APPENDIX A. FOR 5G WIFI RF TEST DATA

A.1 Duty Cycle

Mode	Frequency (MHz)	Duty Cycle (%)	Correction Factor (dB)	1/T (kHz)
a	5180	97.64	0.1	0.48
a	5200	94.06	0.27	0.49
a	5240	94.09	0.26	0.48
n20	5180	97.97	0.09	0.52
n20	5200	93.66	0.28	0.52
n20	5240	97.96	0.09	0.52
n40	5190	91.35	0.39	1.05
n40	5230	93.07	0.31	1.06
ac20	5180	94.15	0.26	0.52
ac20	5200	93.69	0.28	0.52
ac20	5240	91.9	0.37	0.52
ac40	5190	92.31	0.35	1.04
ac40	5230	87.16	0.6	1.05
ac80	5210	76.67	1.15	2.17

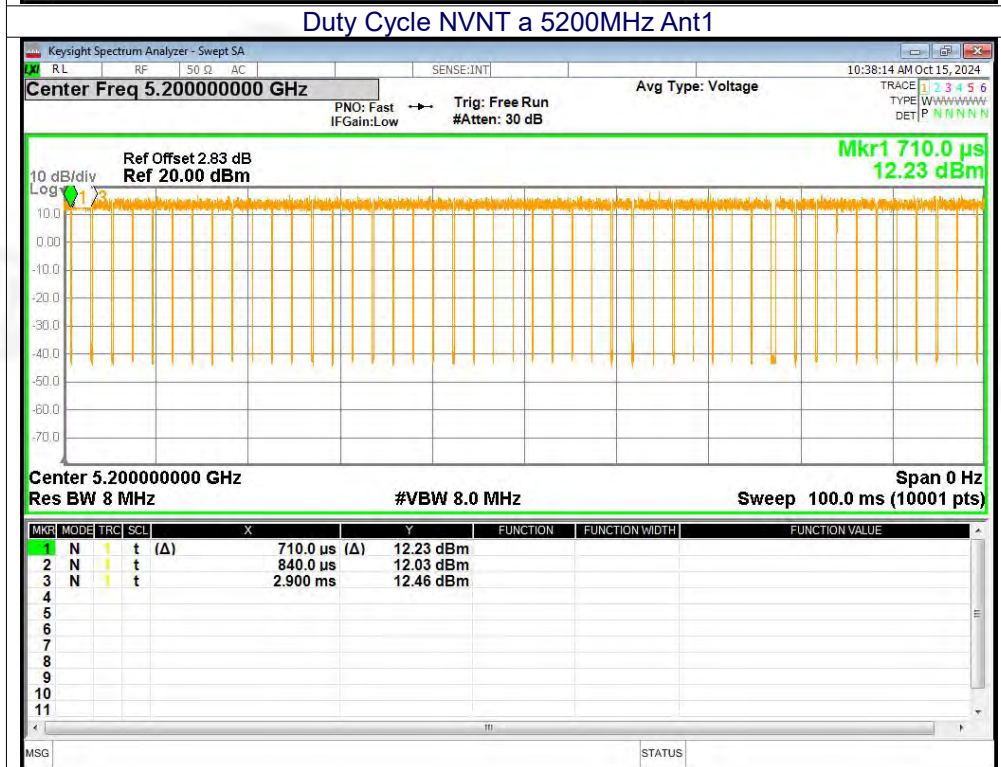
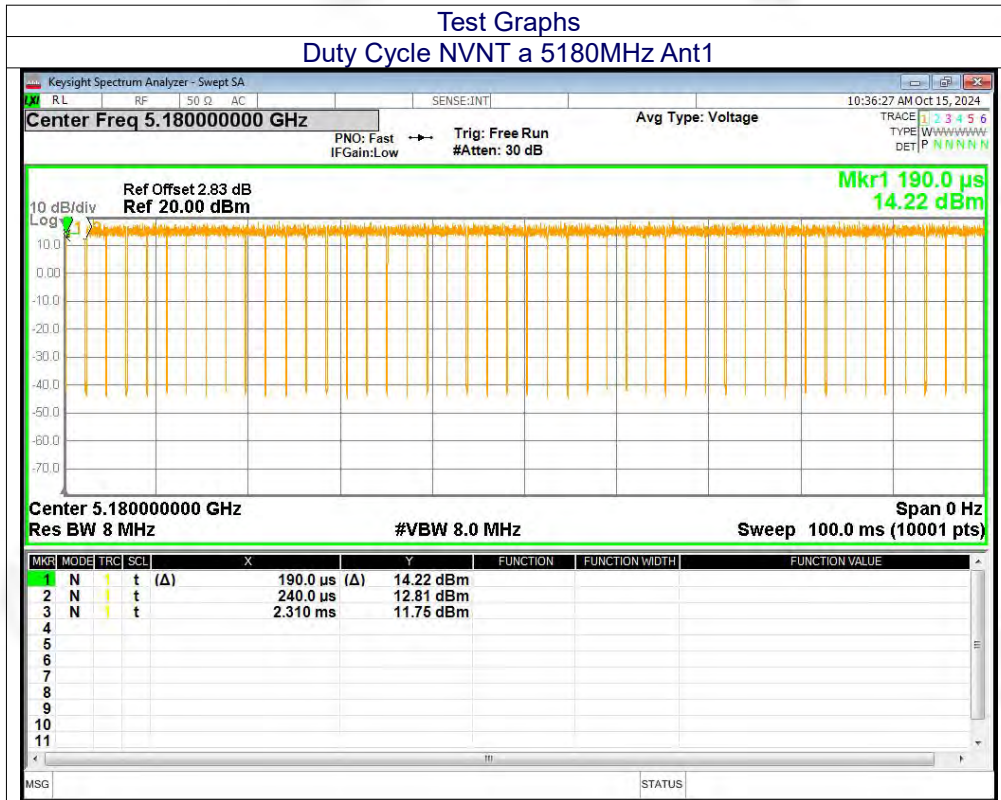

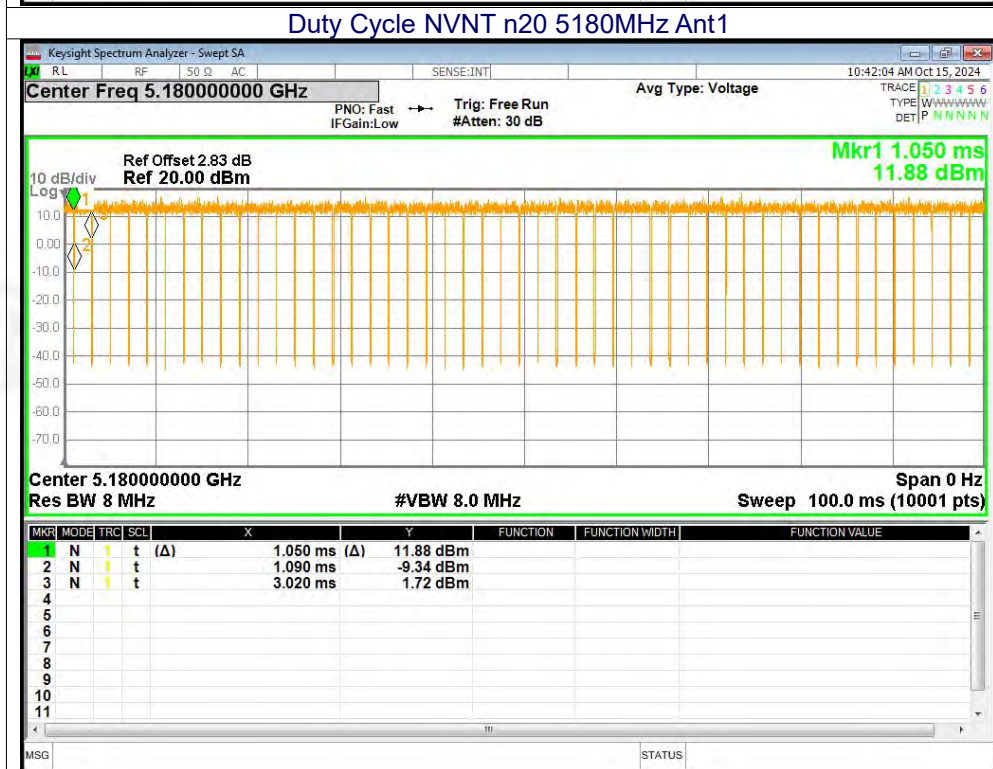
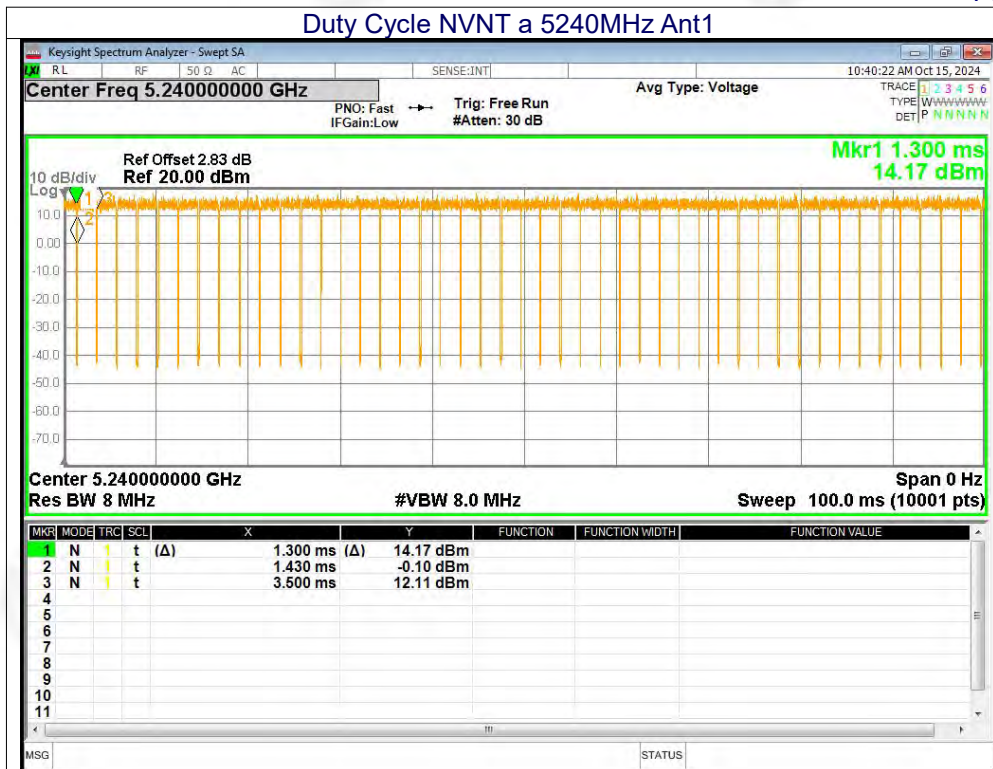

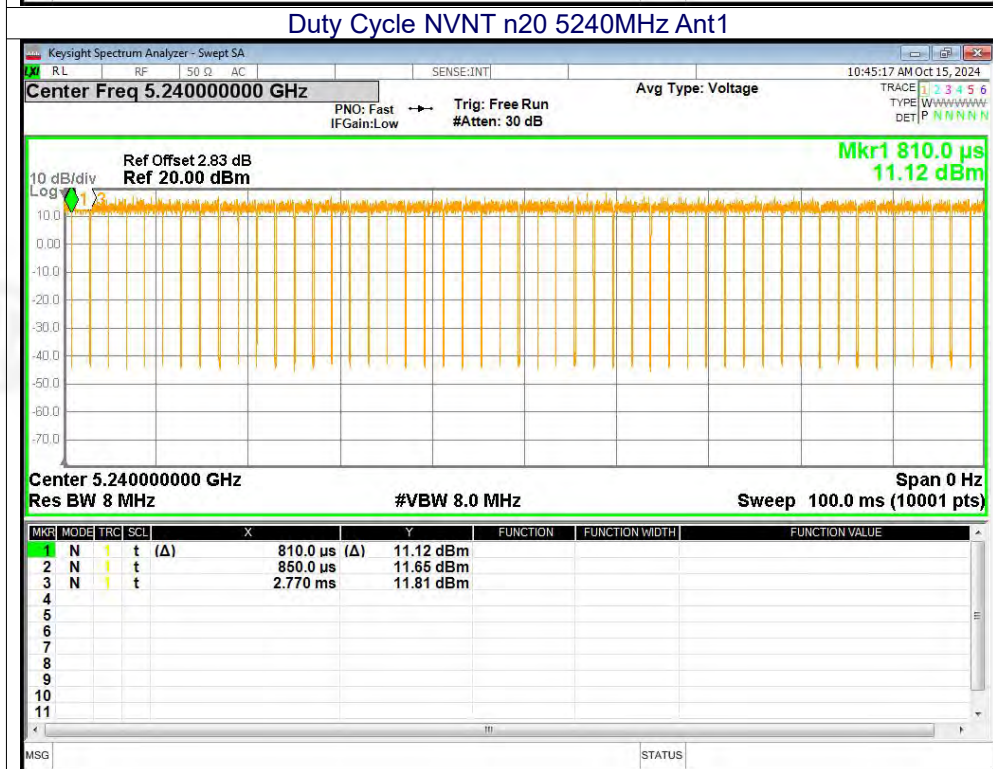
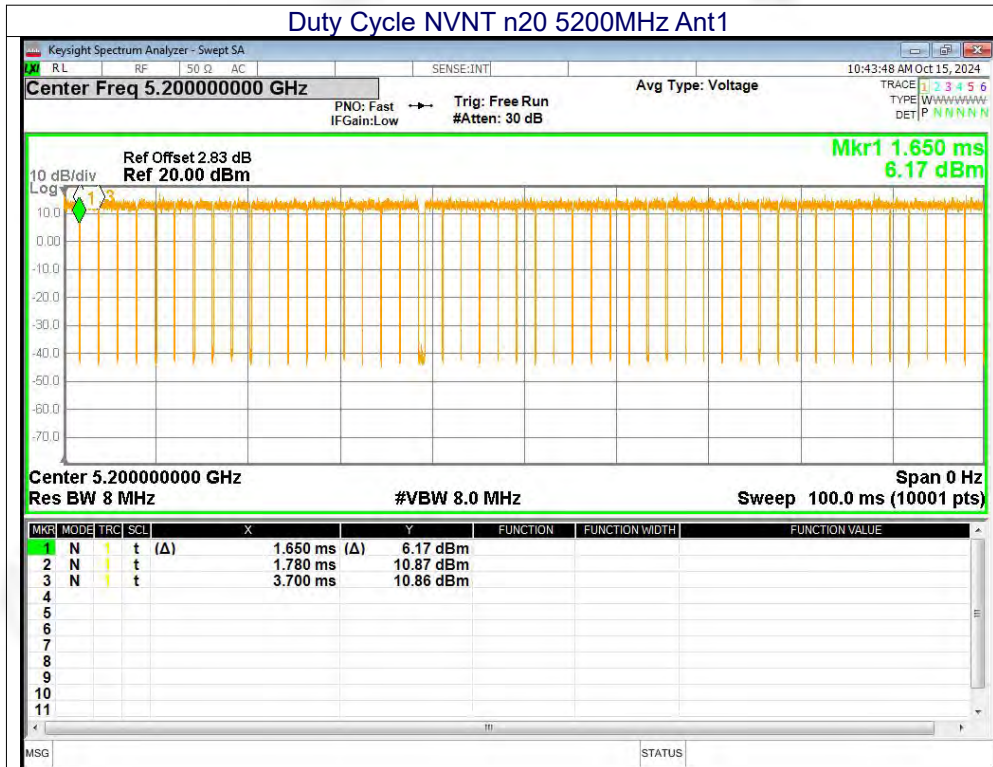

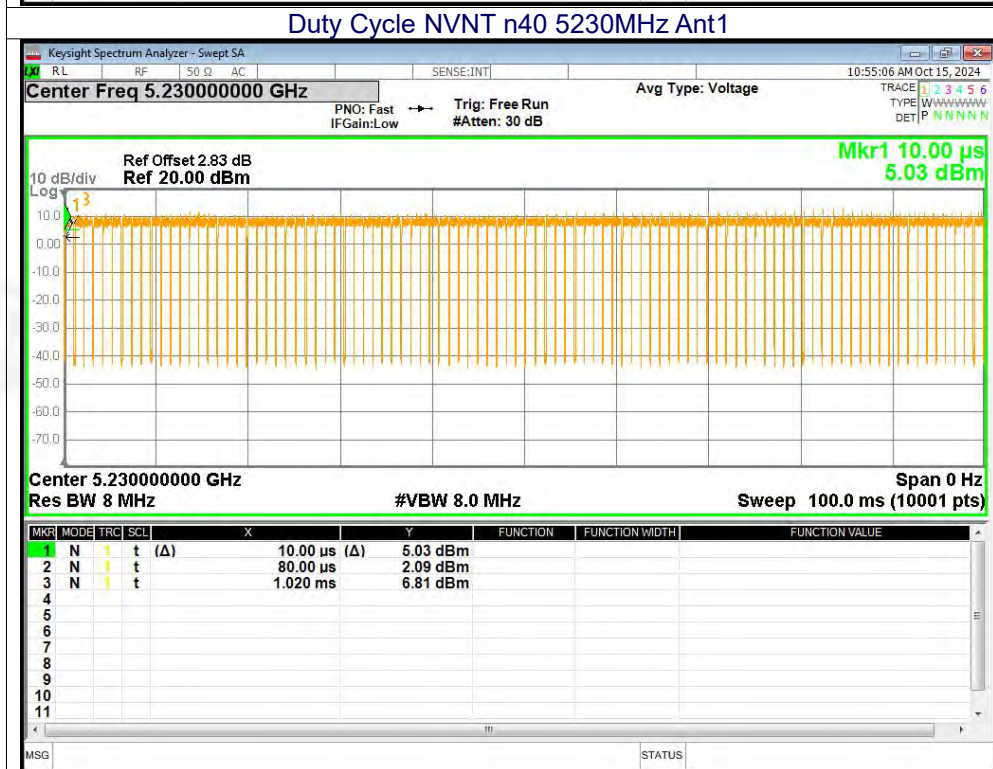
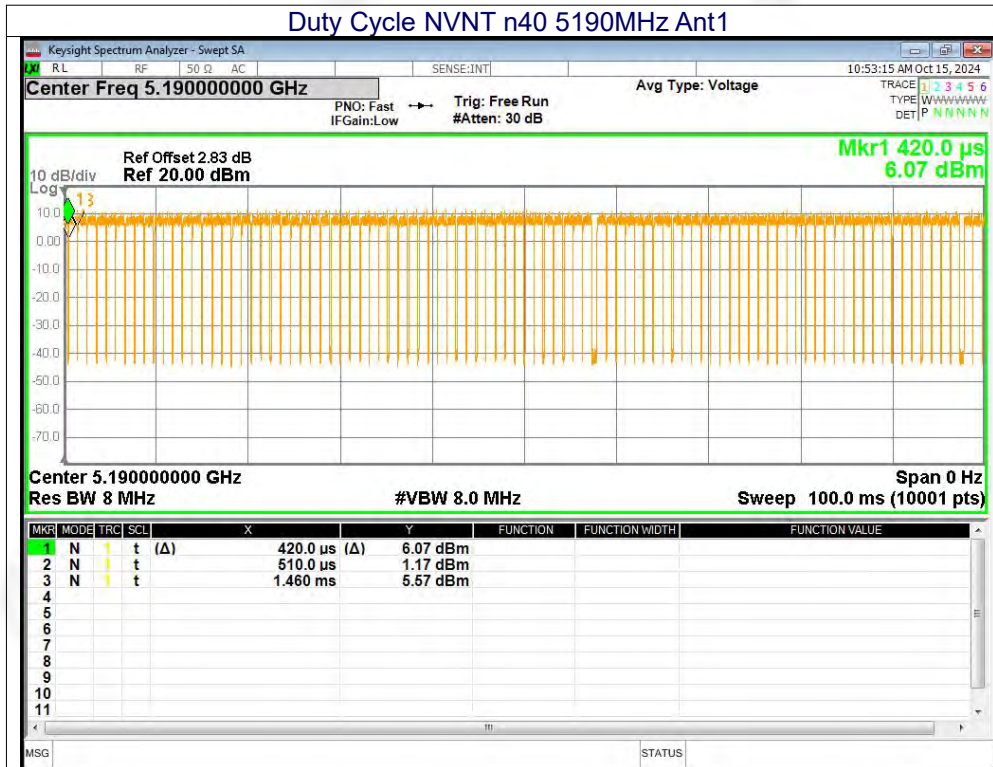

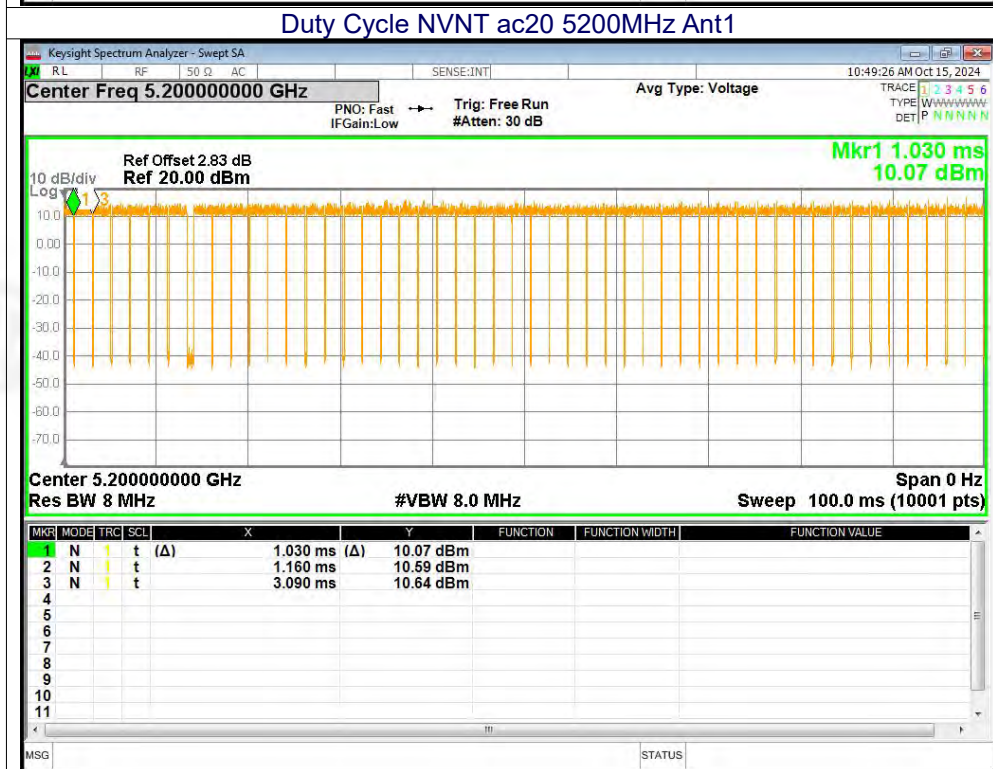
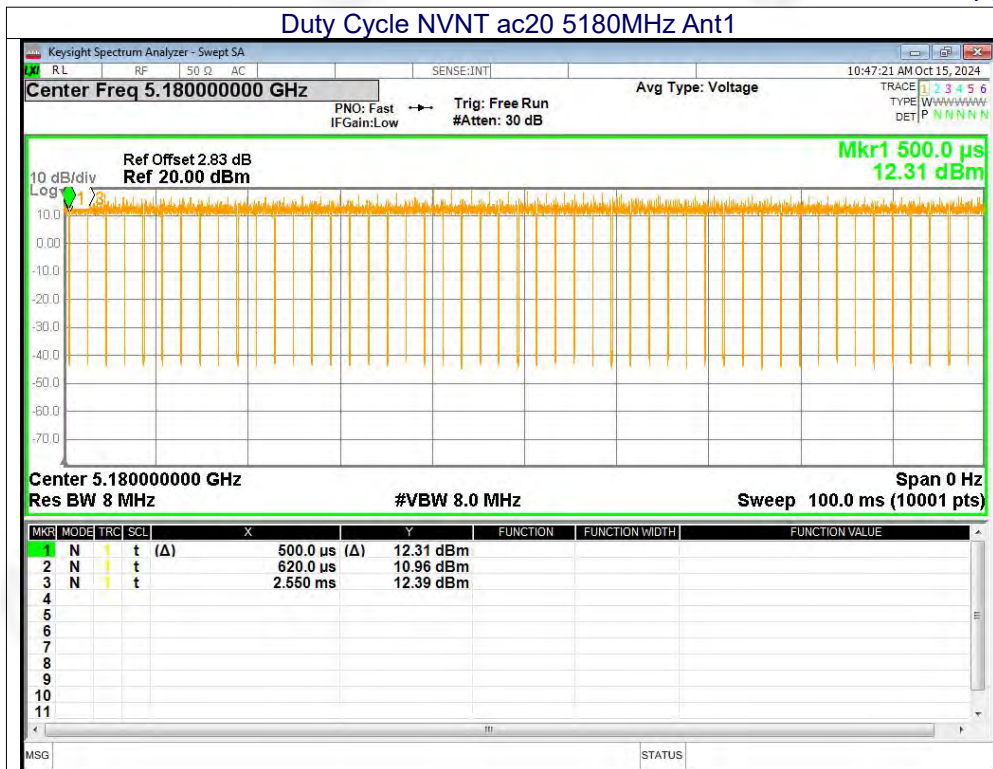

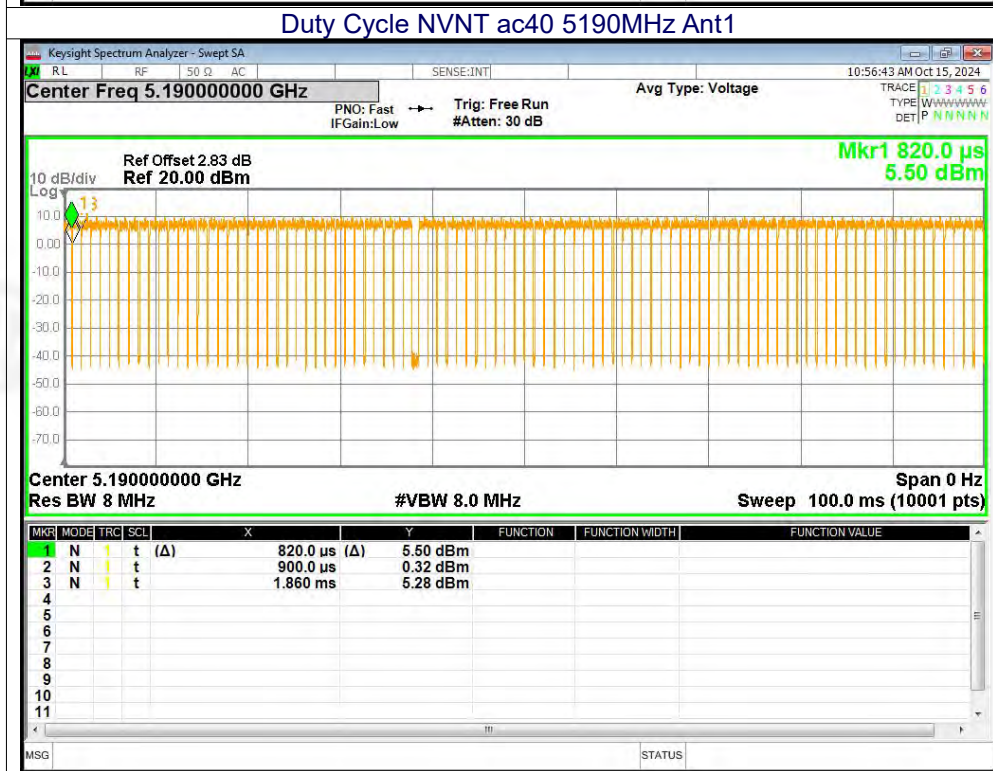
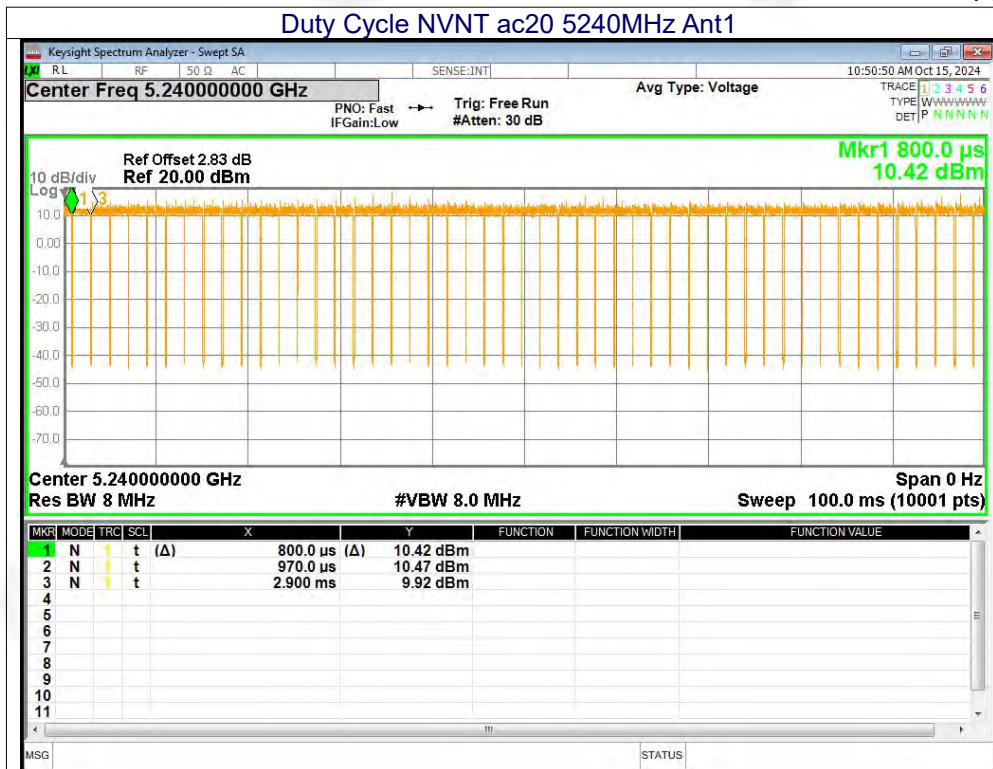

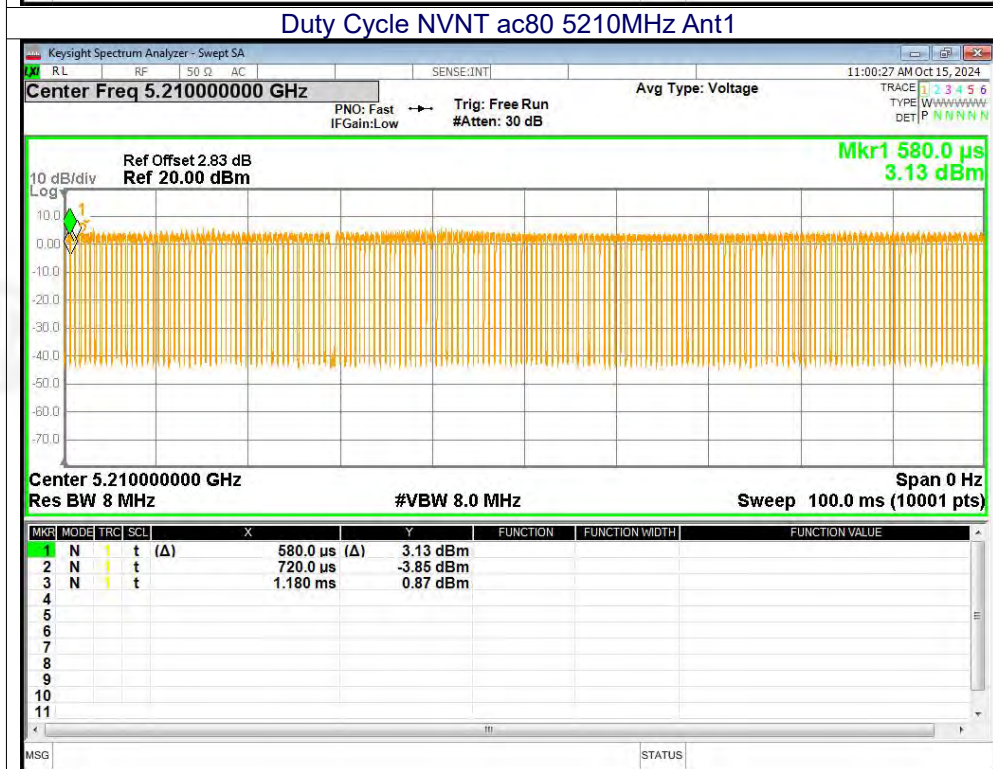
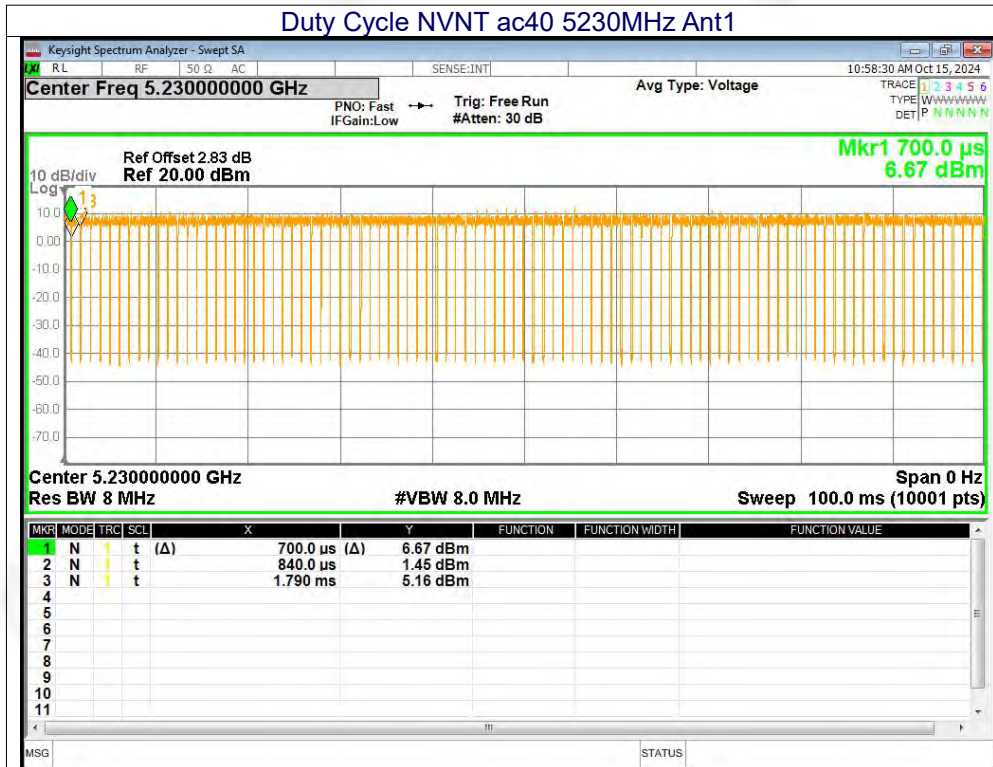

**A.2 Maximum Conducted Output Power**

Mode	Frequency (MHz)	Conducted Power (dBm)	Duty Factor (dB)	Total Power (dBm)	Limit (dBm)	Verdict
a	5180	11.22	0.1	11.32	24	Pass
a	5200	9.82	0.27	10.09	24	Pass
a	5240	10.35	0.26	10.61	24	Pass
n20	5180	9.4	0.09	9.49	24	Pass
n20	5200	9.51	0.28	9.79	24	Pass
n20	5240	9.67	0.09	9.76	24	Pass
n40	5190	6.65	0.39	7.04	24	Pass
n40	5230	6.98	0.31	7.29	24	Pass
ac20	5180	8.86	0.26	9.12	24	Pass
ac20	5200	8.57	0.28	8.85	24	Pass
ac20	5240	8.38	0.37	8.75	24	Pass
ac40	5190	6.25	0.35	6.6	24	Pass
ac40	5230	6.52	0.6	7.12	24	Pass
ac80	5210	5.5	1.15	6.65	24	Pass

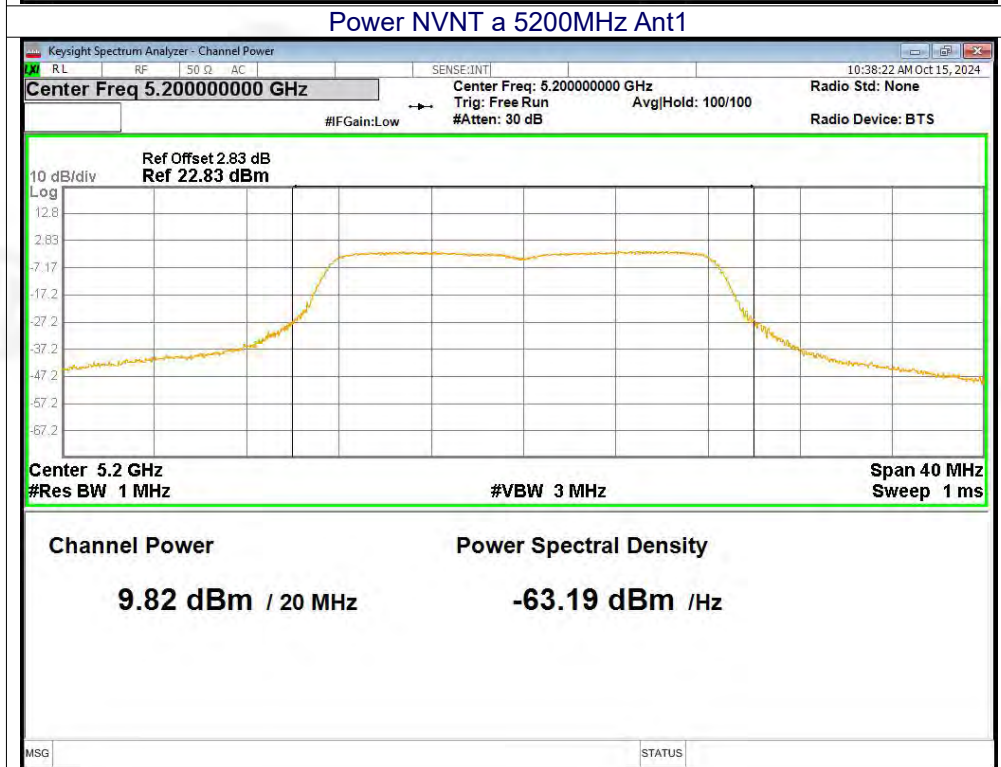
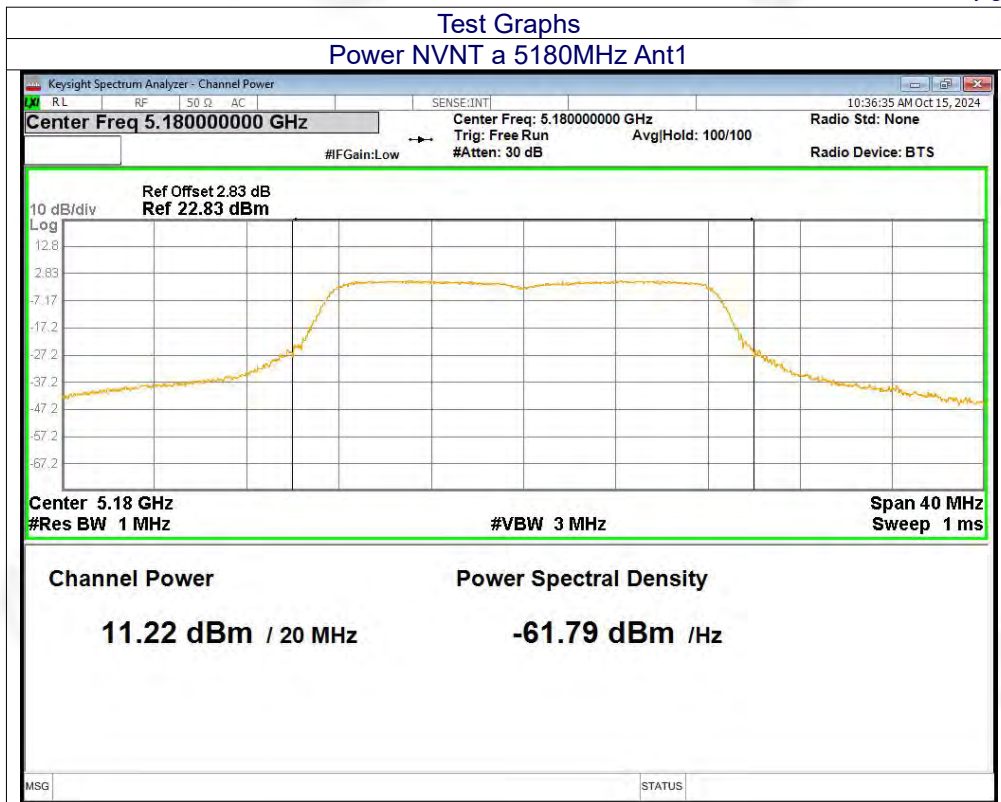

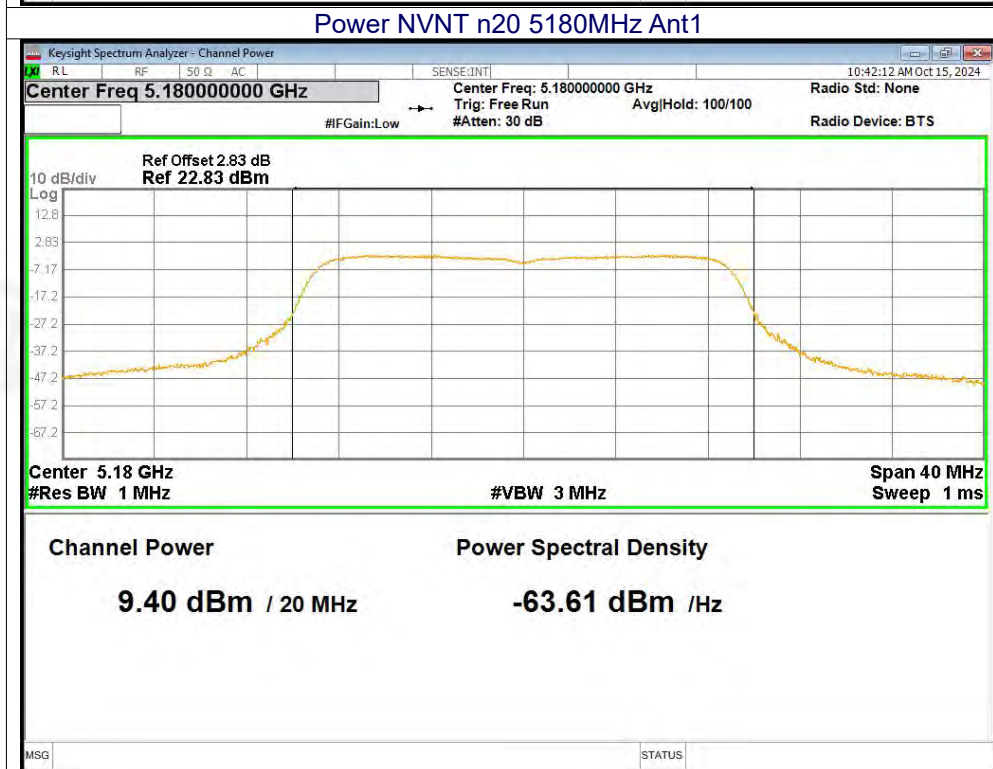
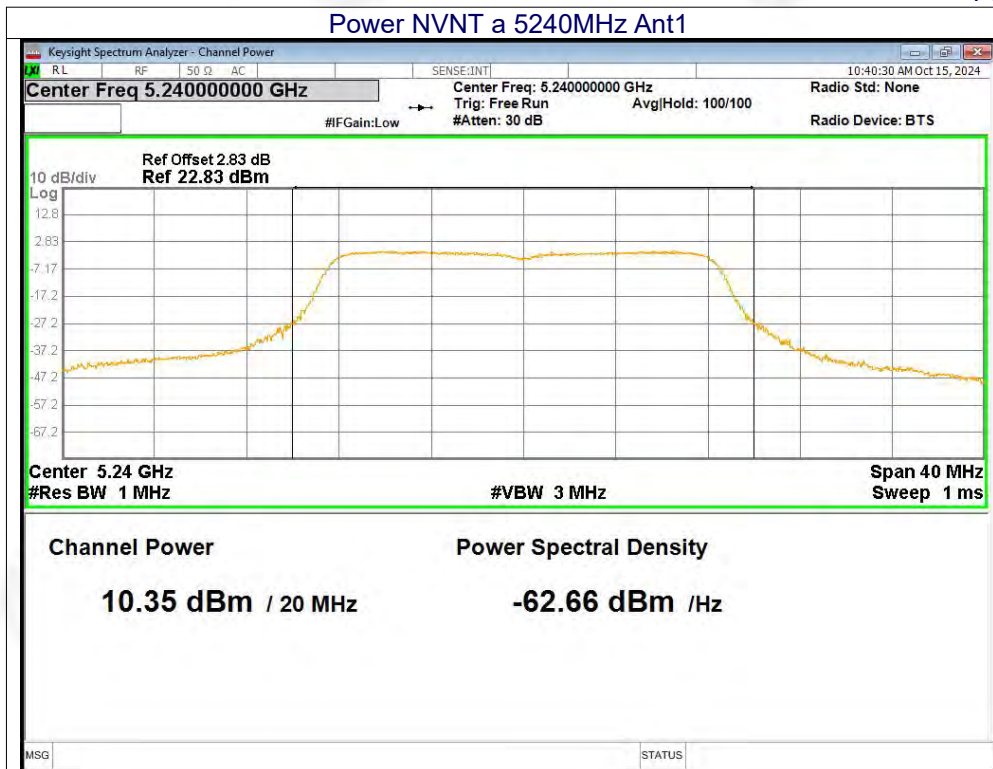

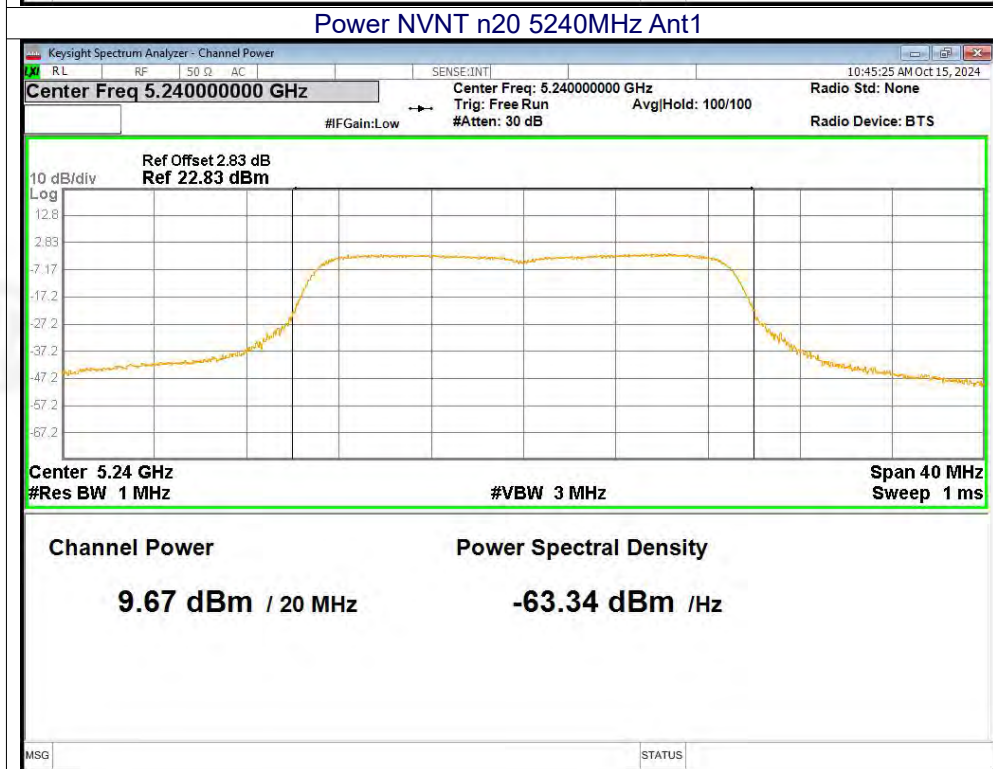
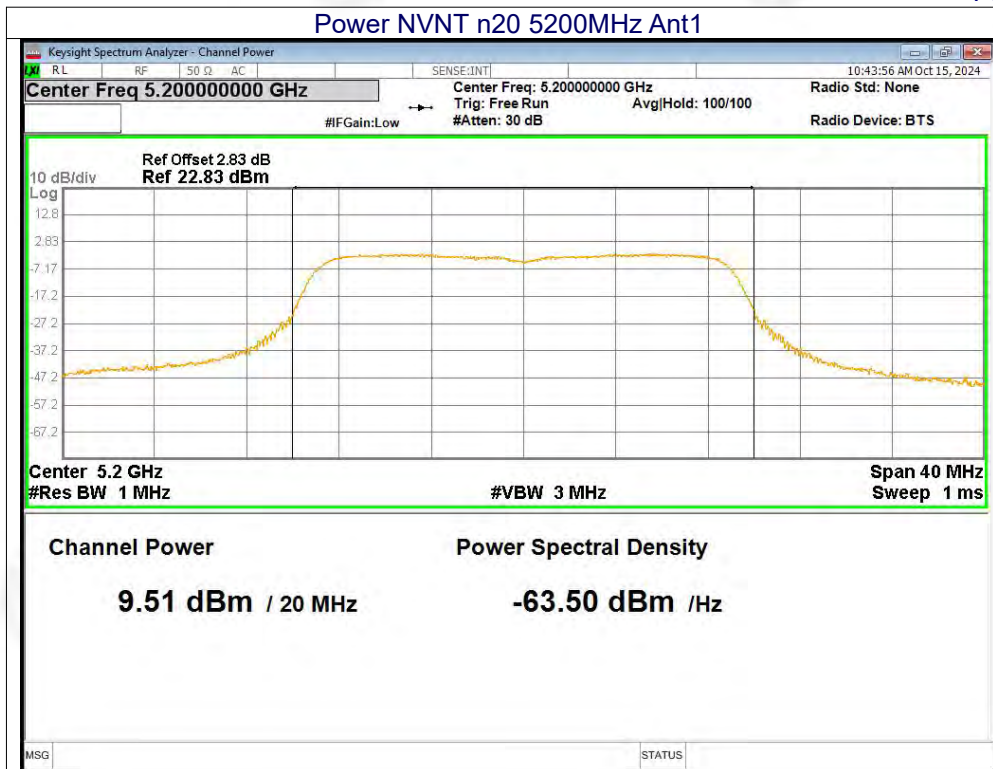

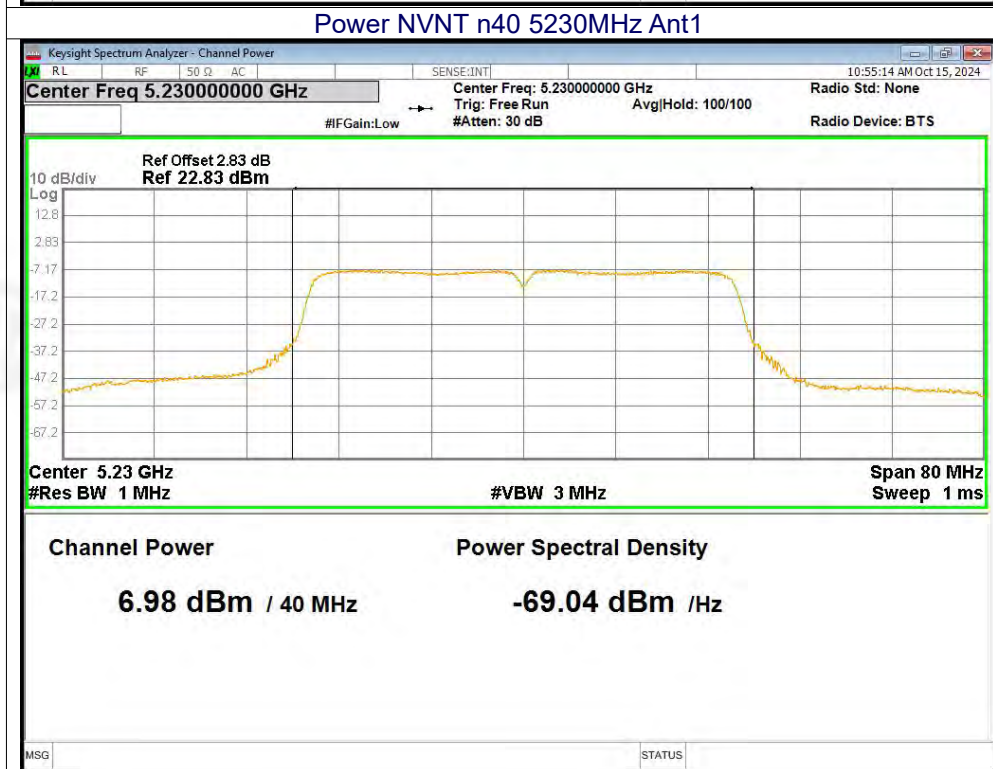
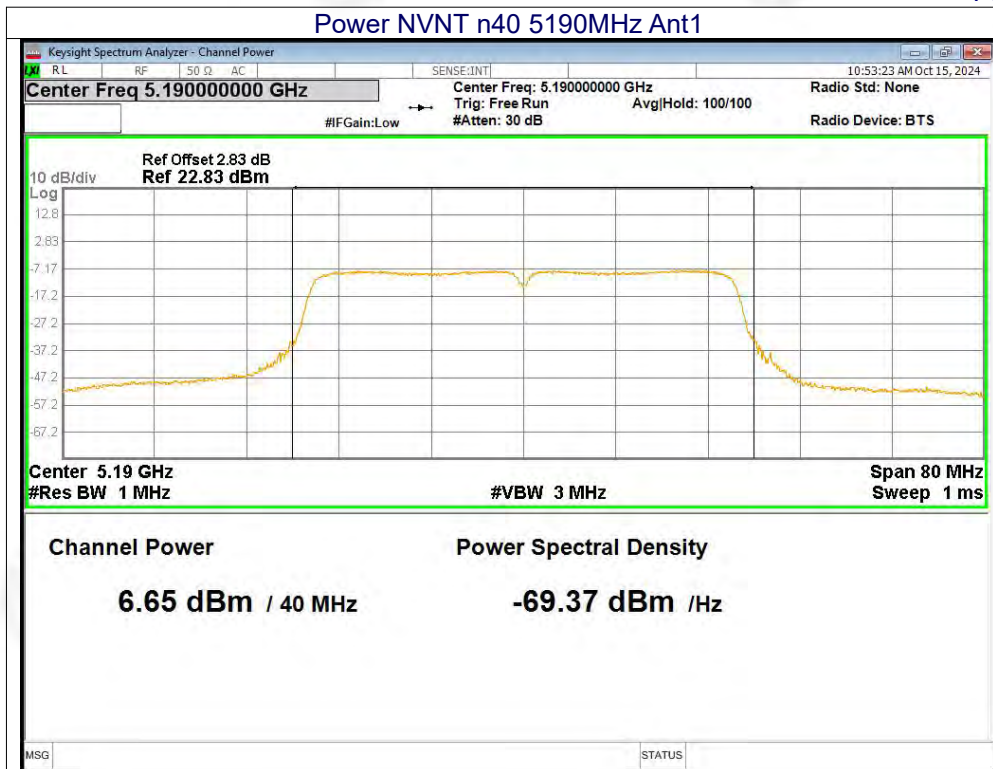

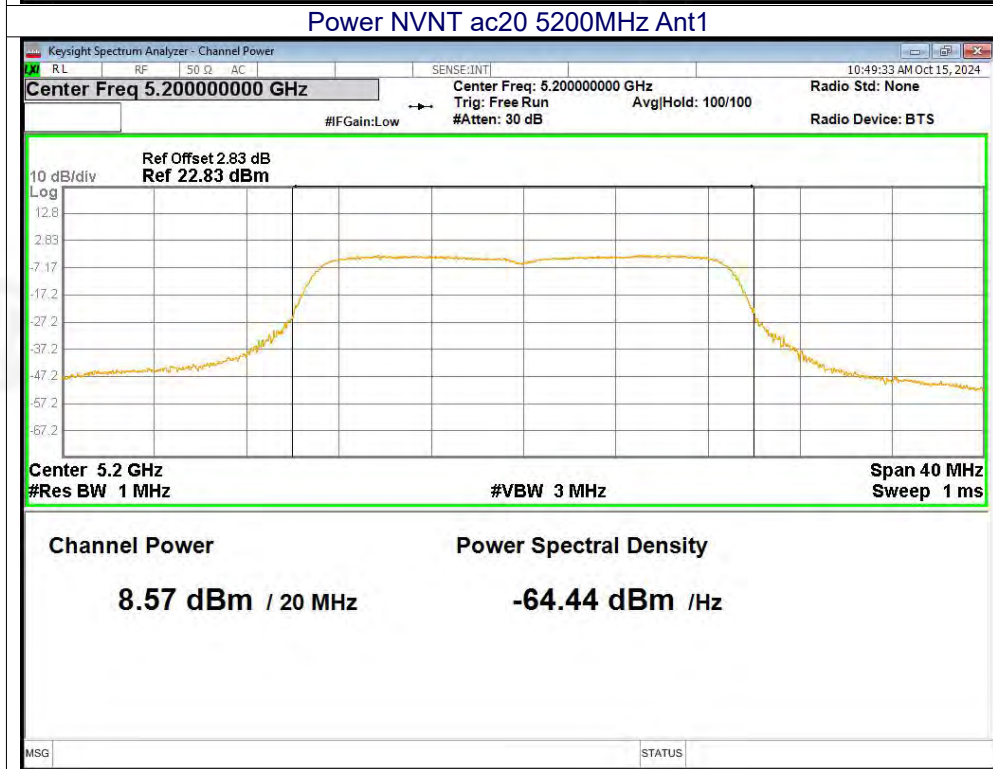
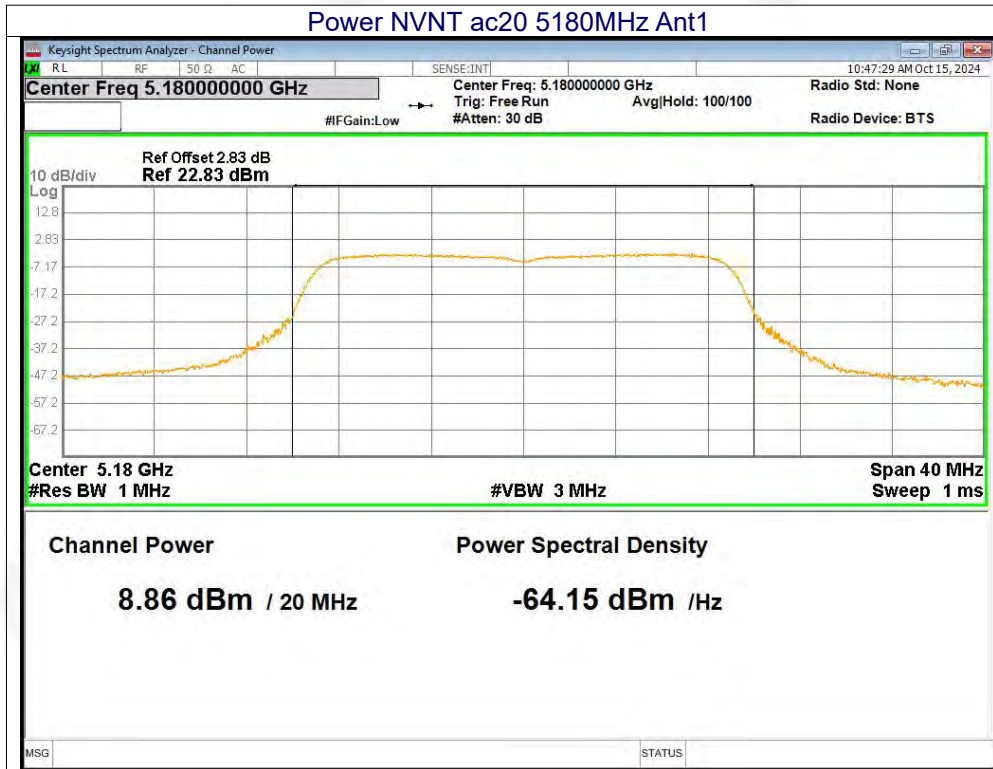

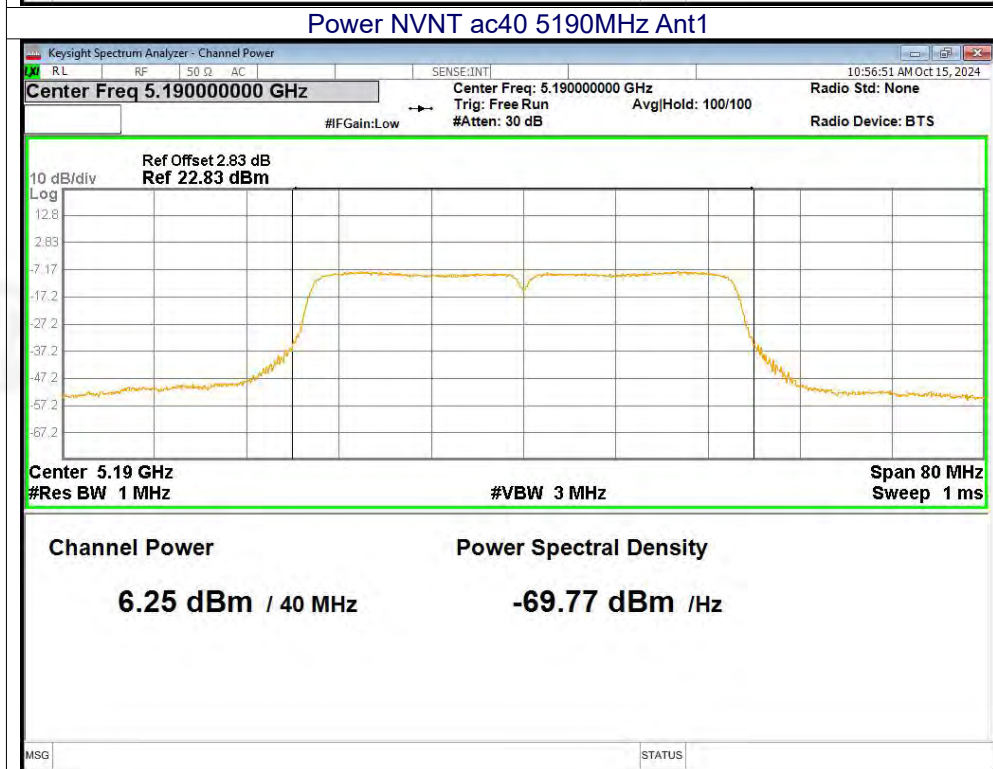
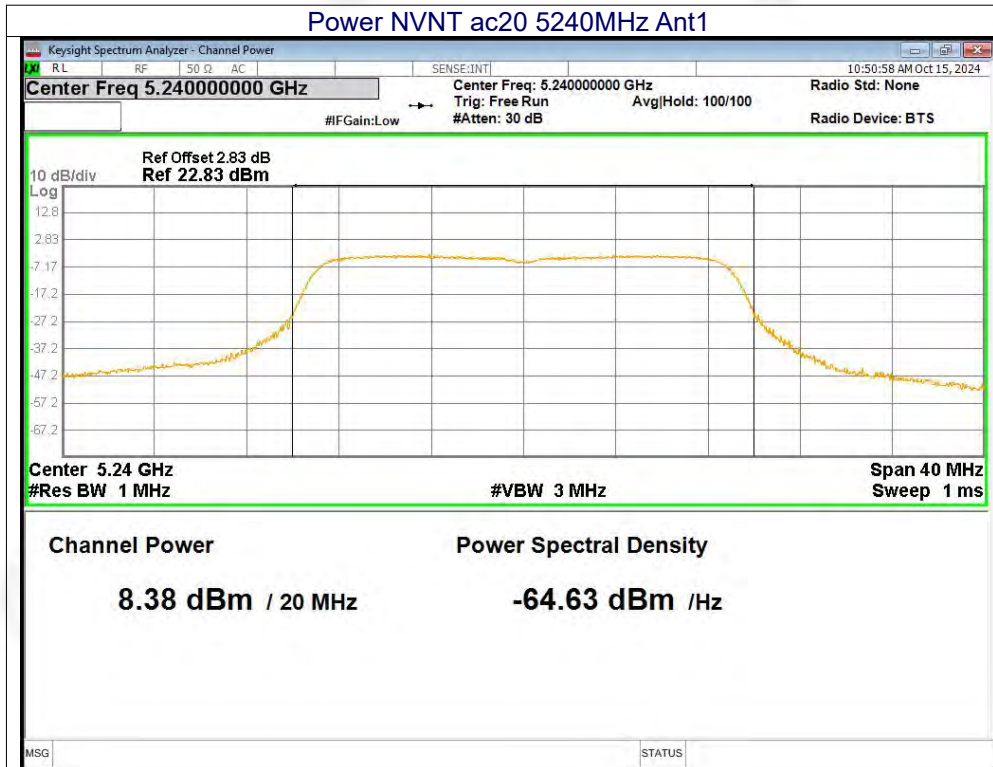



Power NVNT ac40 5230MHz Ant1

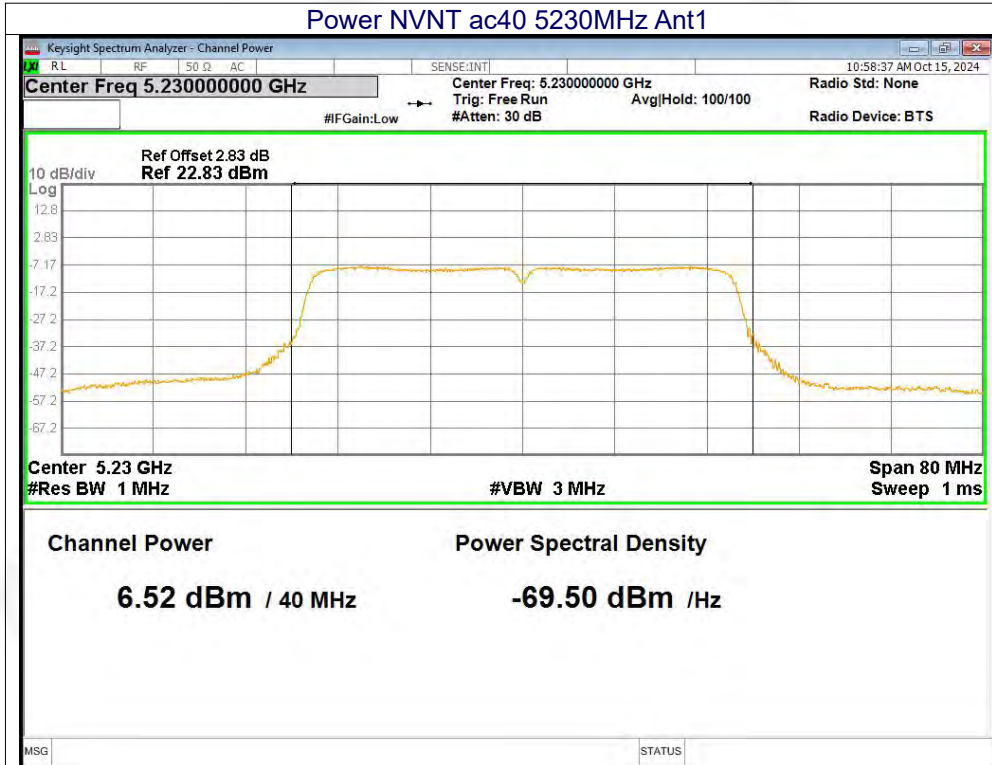

Power NVNT ac80 5210MHz Ant1

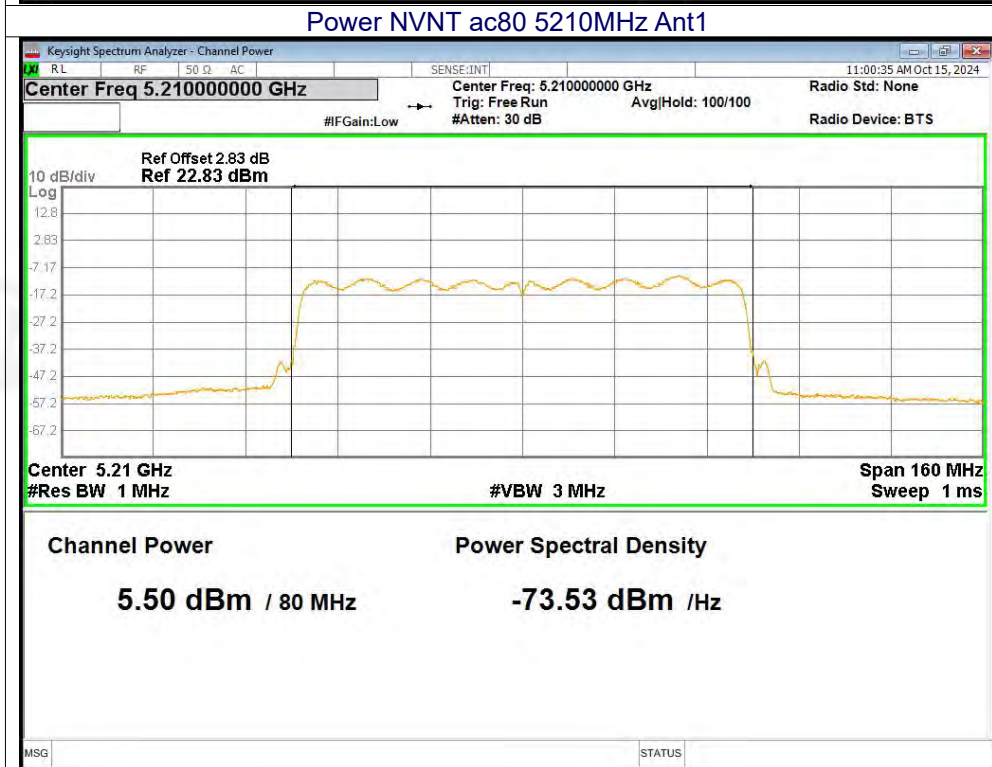



A.4 Occupied Channel Bandwidth

Mode	Frequency (MHz)	99% OBW (MHz)
a	5180	16.551
a	5200	16.502
a	5240	16.565
n20	5180	17.626
n20	5200	17.66
n20	5240	17.625
n40	5190	36.149
n40	5230	36.198
ac20	5180	17.623
ac20	5200	17.662
ac20	5240	17.641
ac40	5190	36.16
ac40	5230	36.109
ac80	5210	75.249

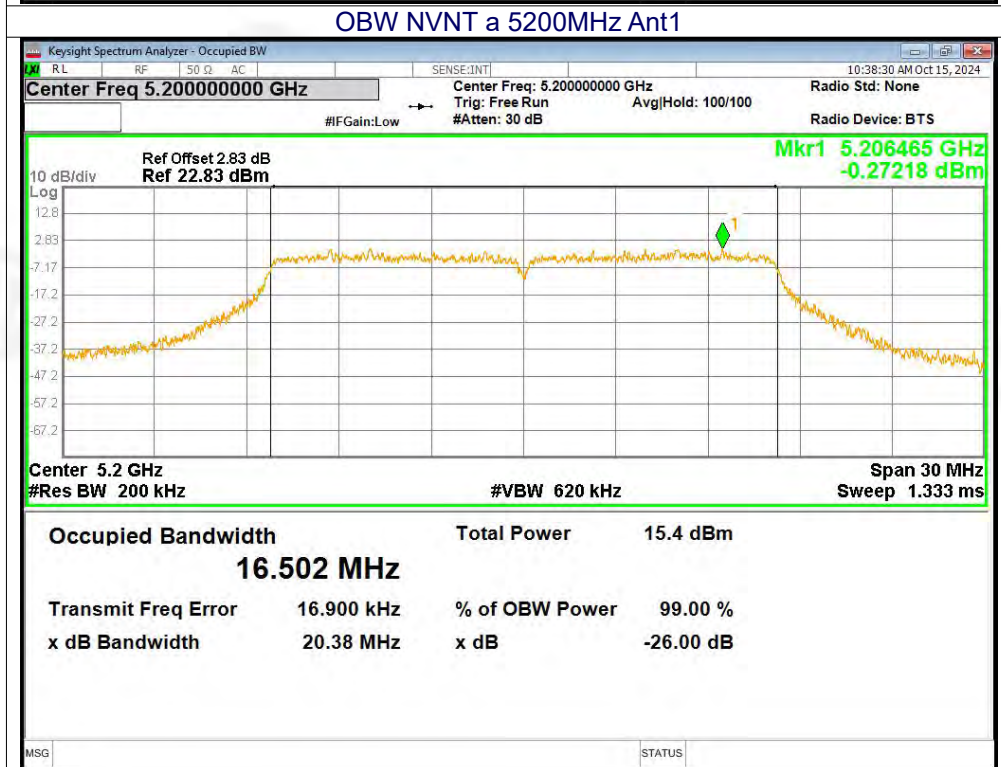
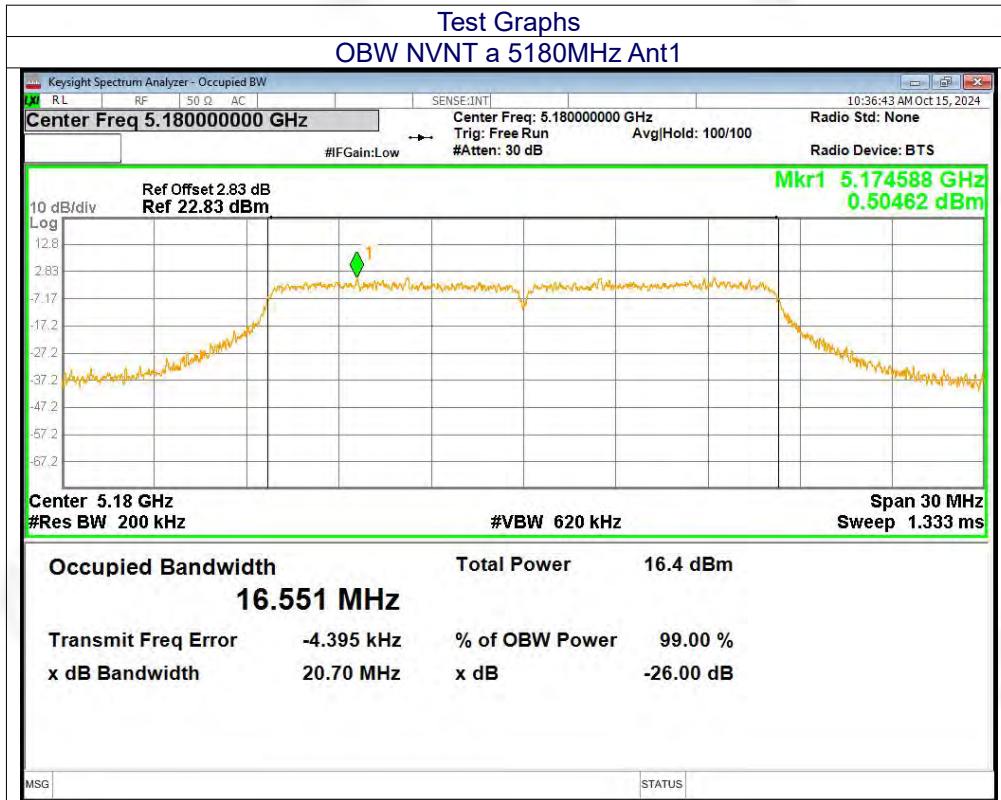

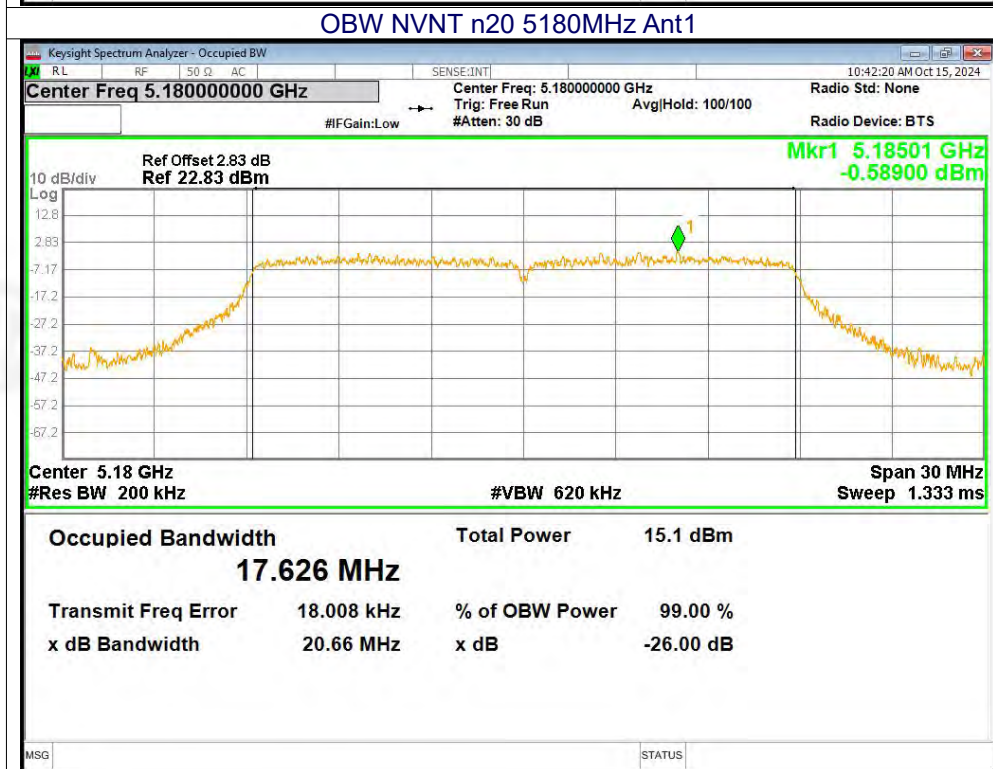
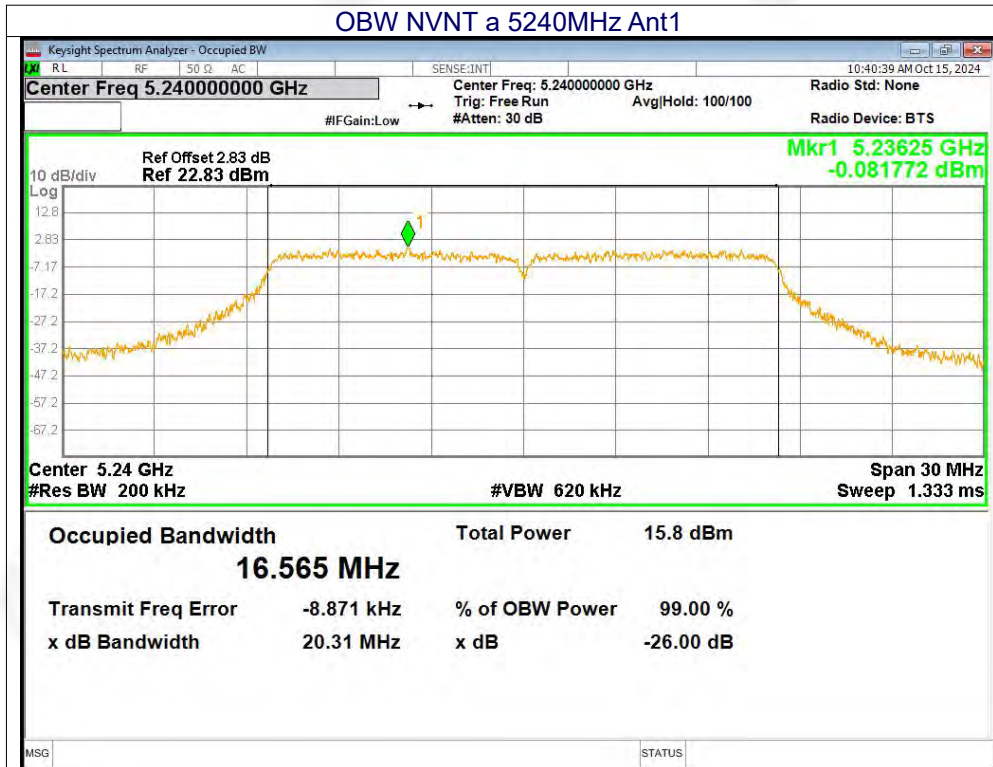

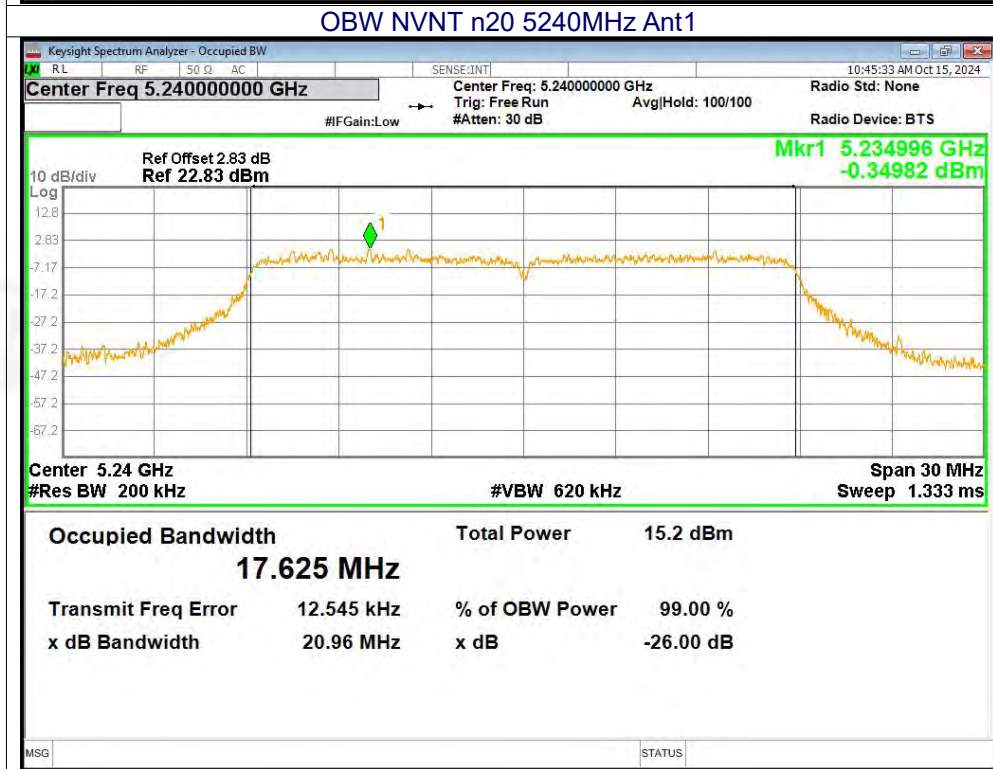
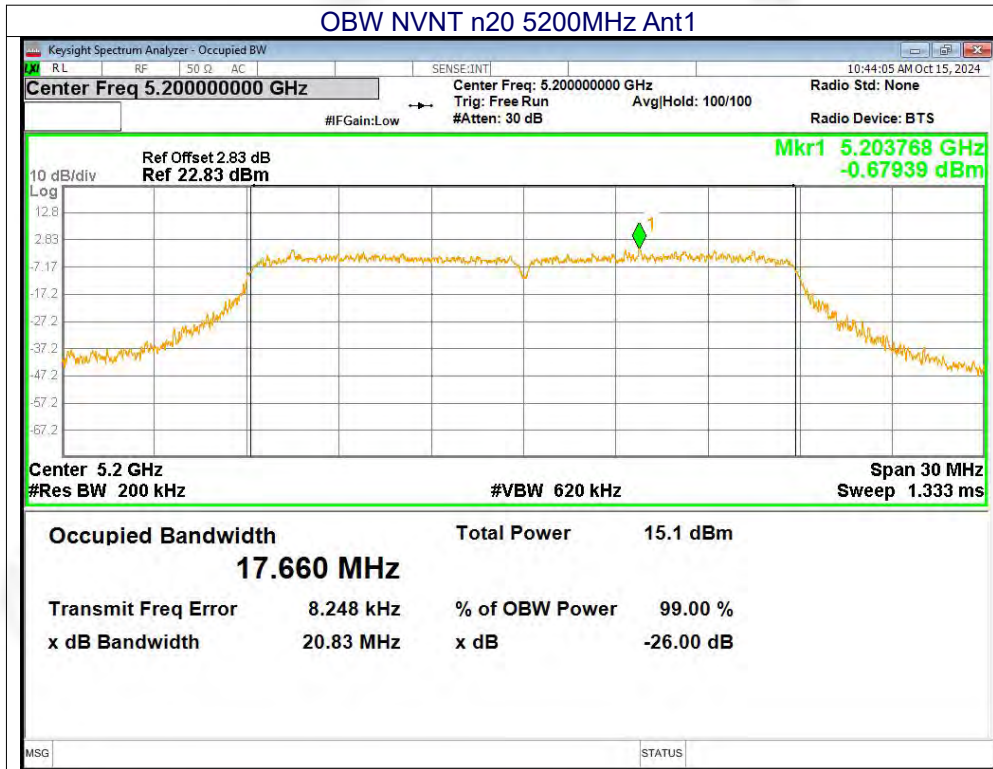

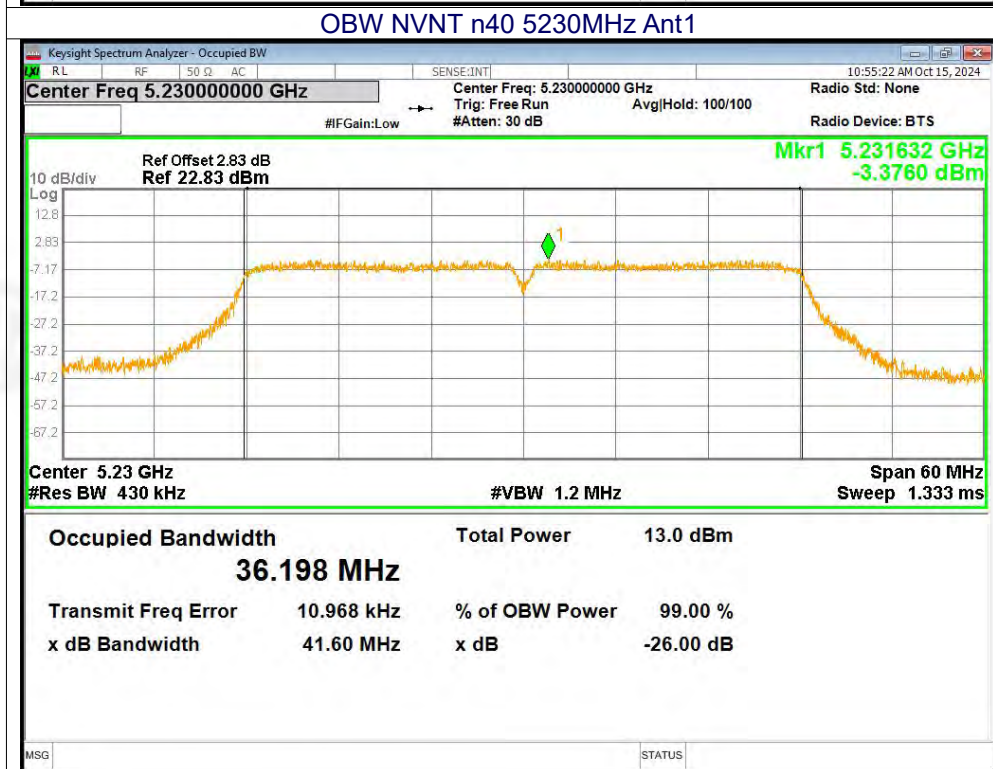
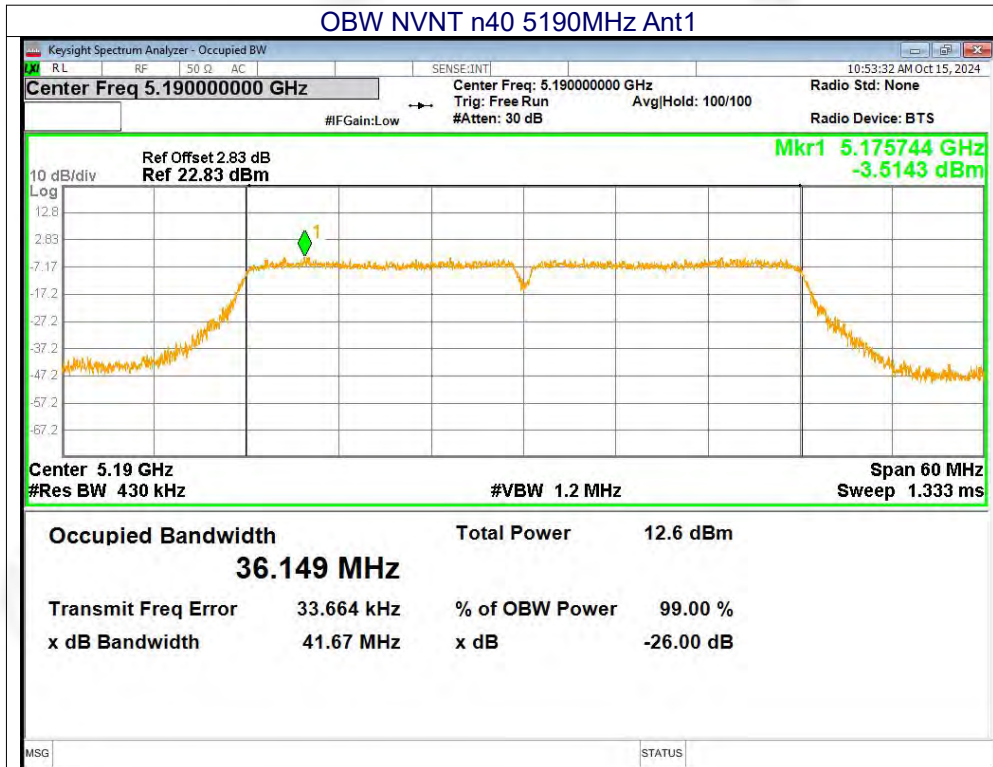

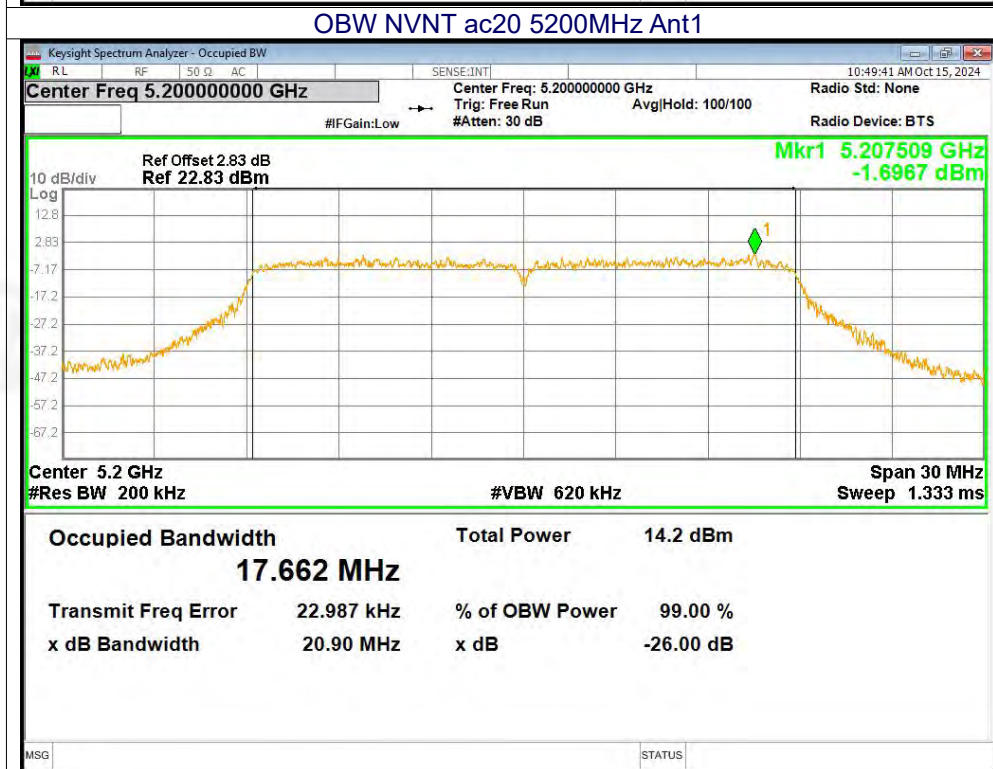
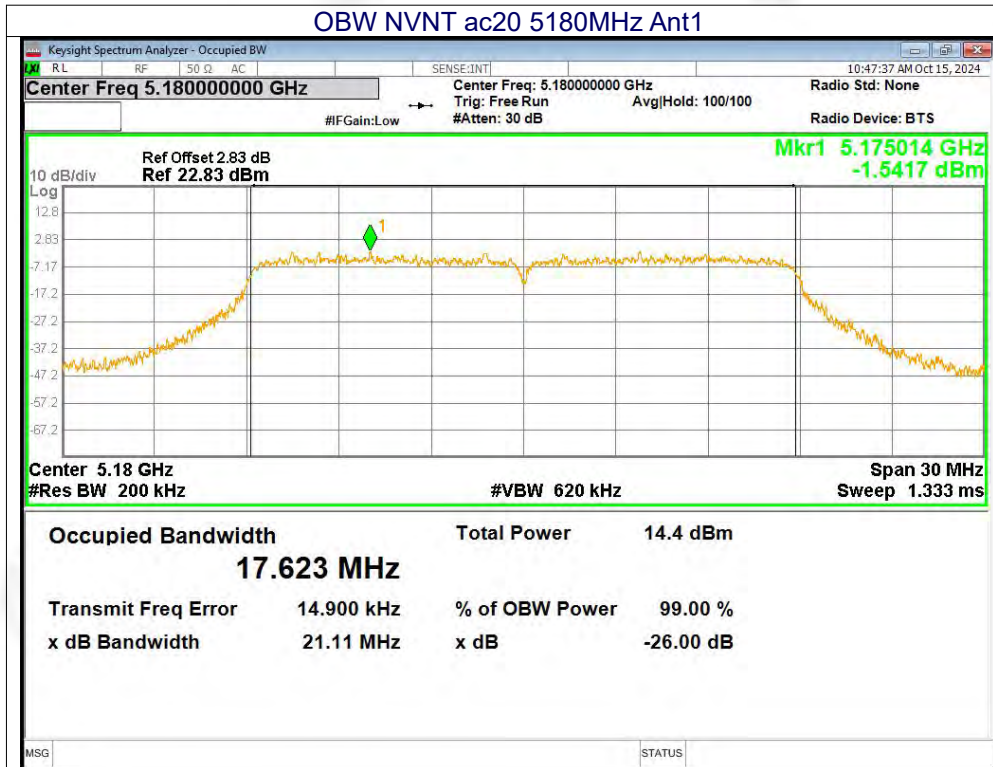



OBW NVNT ac20 5240MHz Ant1

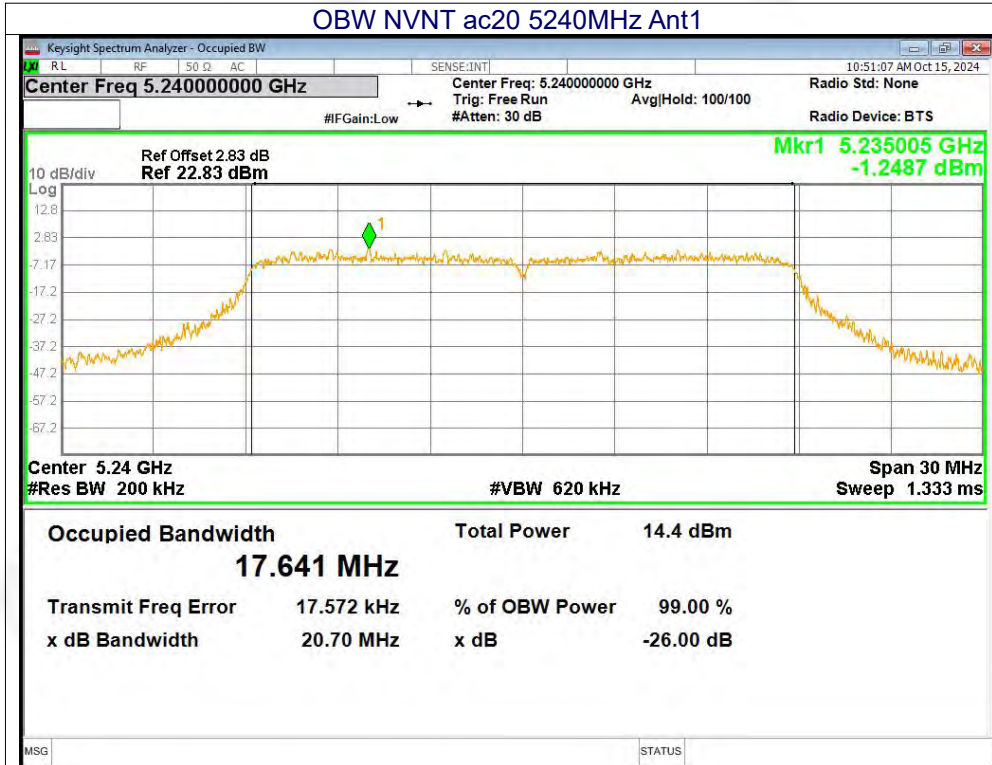

OBW NVNT ac40 5190MHz Ant1

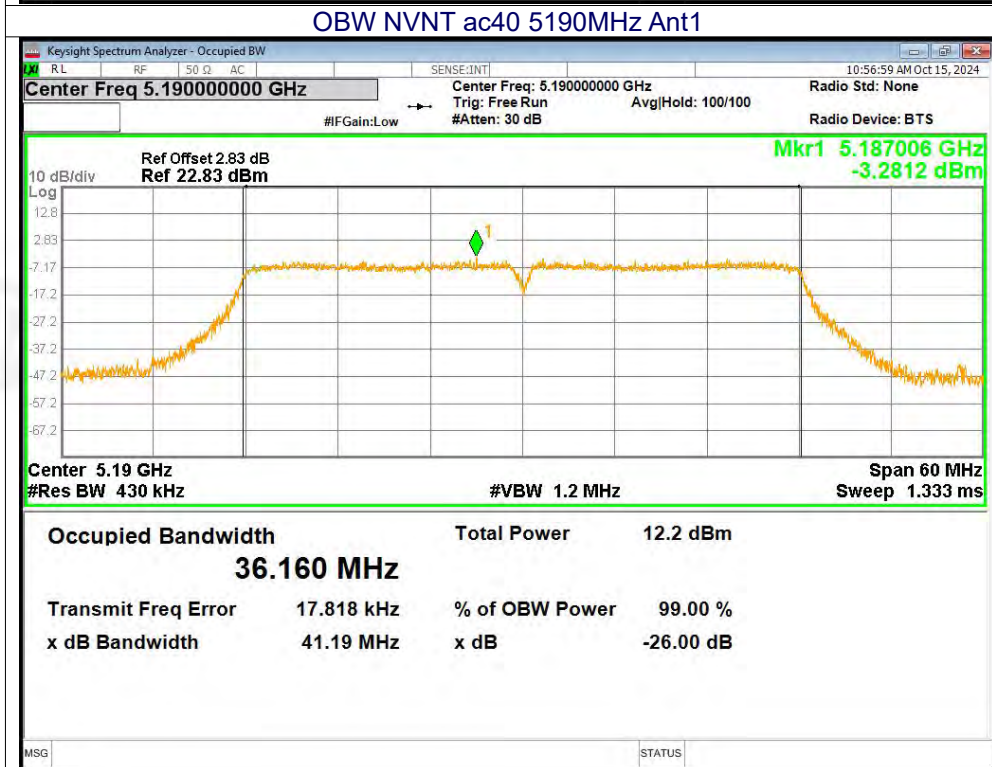

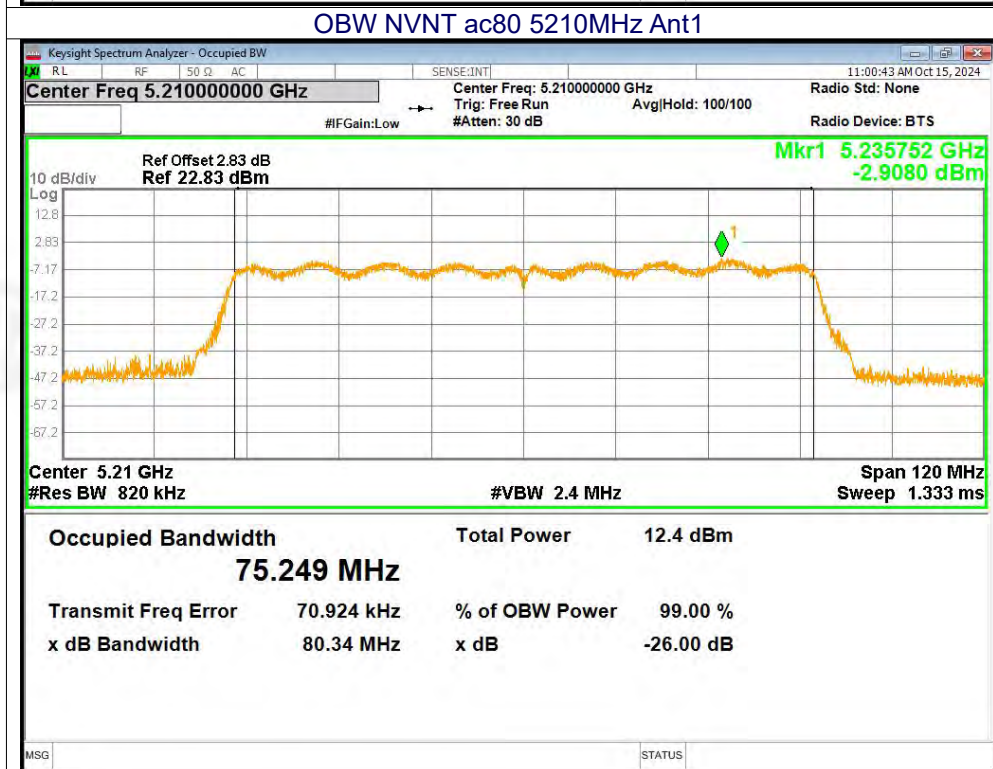
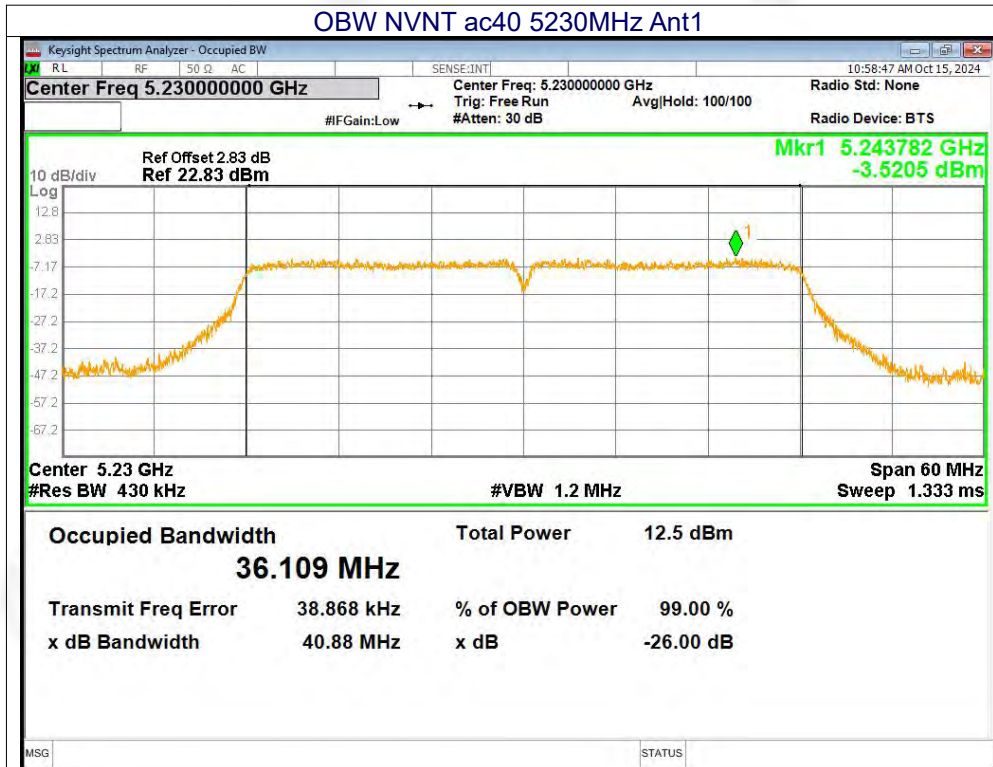

**A.5 Maximum Power Spectral Density Level**

Mode	Frequency (MHz)	Conducted PSD (dBm/MHz)	Duty Factor (dB)	Total PSD (dBm/MHz)	Limit (dBm/MHz)	Verdict
a	5180	-2.13	0.1	-2.03	11	Pass
a	5200	-5.04	0.27	-4.77	11	Pass
a	5240	-3	0.26	-2.74	11	Pass
n20	5180	-4.54	0.09	-4.45	11	Pass
n20	5200	-4.39	0.28	-4.11	11	Pass
n20	5240	-4.55	0.09	-4.46	11	Pass
n40	5190	-10.84	0.39	-10.45	11	Pass
n40	5230	-11.42	0.31	-11.11	11	Pass
ac20	5180	-5.35	0.26	-5.09	11	Pass
ac20	5200	-6.26	0.28	-5.98	11	Pass
ac20	5240	-4.82	0.37	-4.45	11	Pass
ac40	5190	-11.98	0.35	-11.63	11	Pass
ac40	5230	-11.27	0.6	-10.67	11	Pass
ac80	5210	-17.07	1.15	-15.92	11	Pass

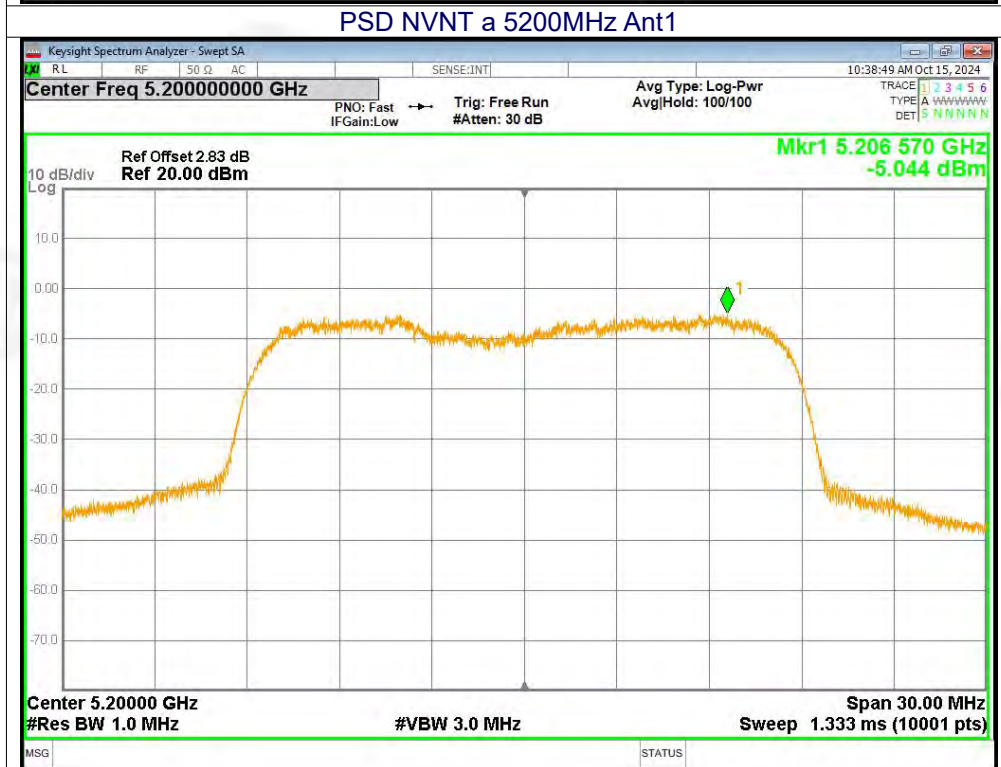
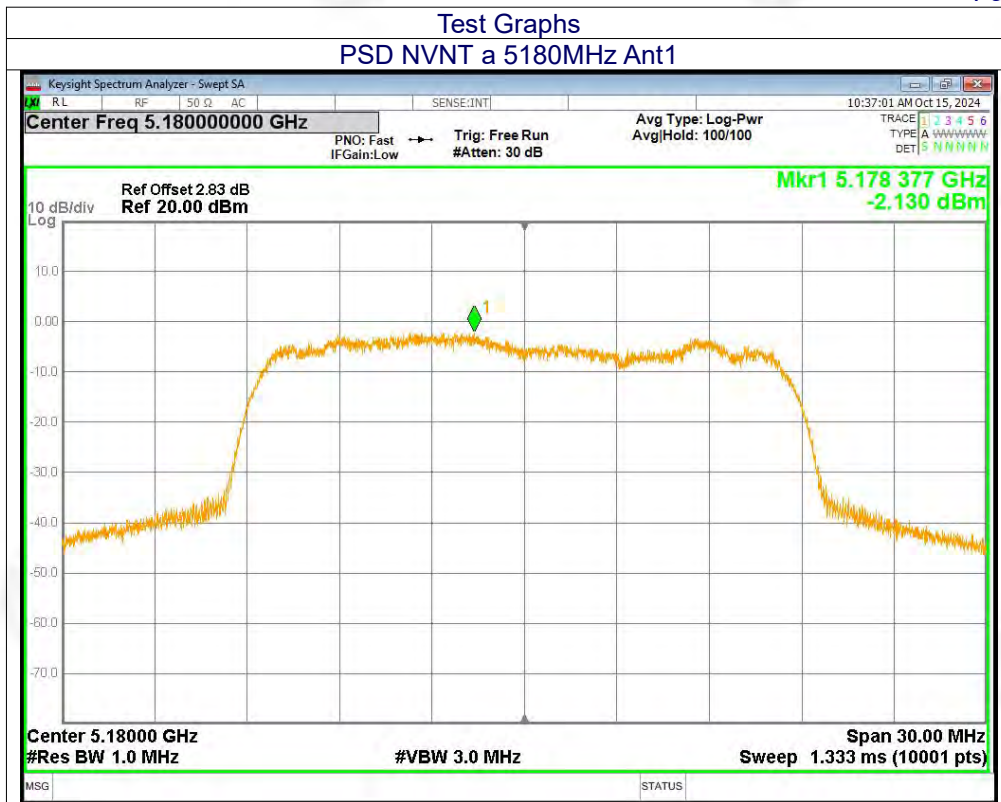

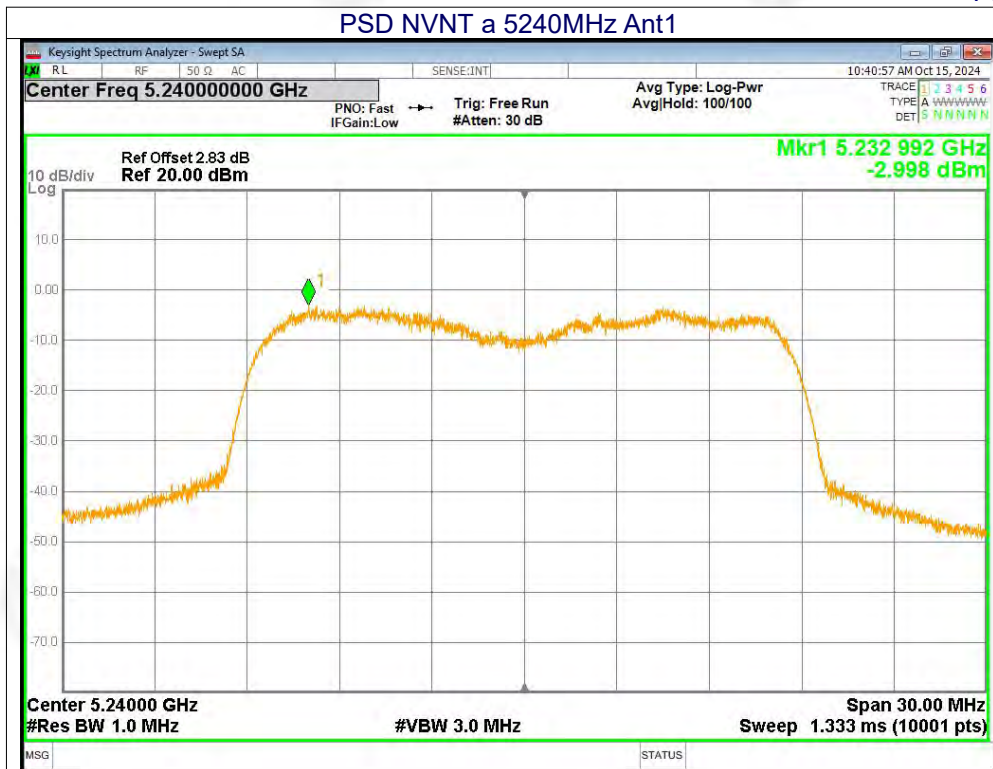

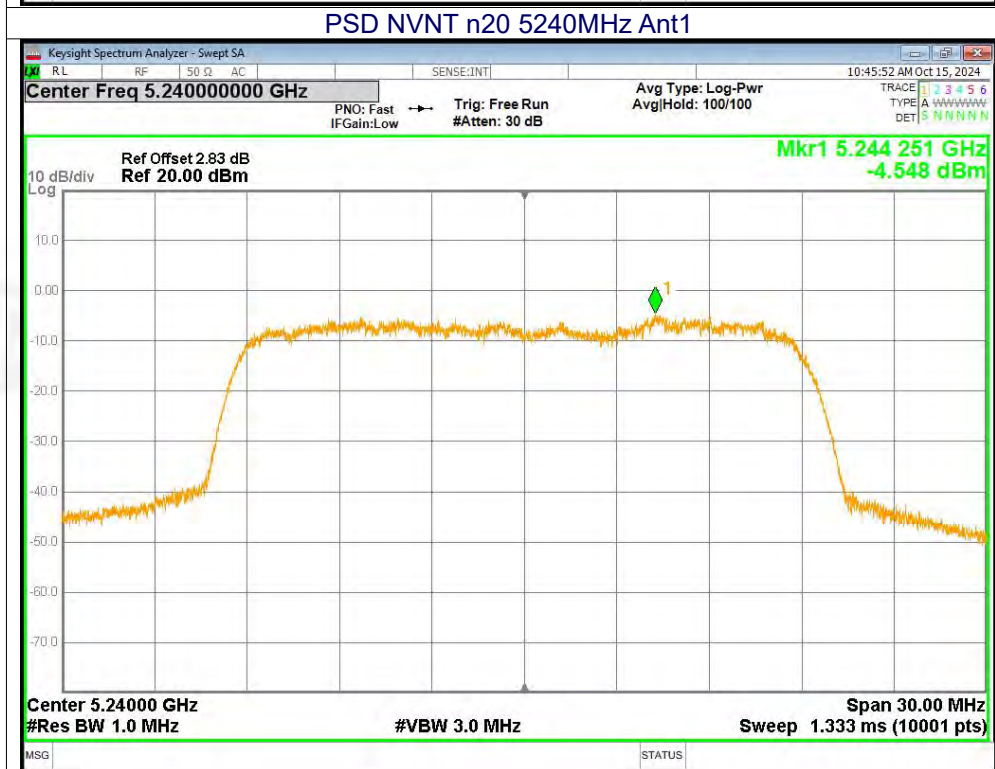



PSD NVNT n40 5190MHz Ant1

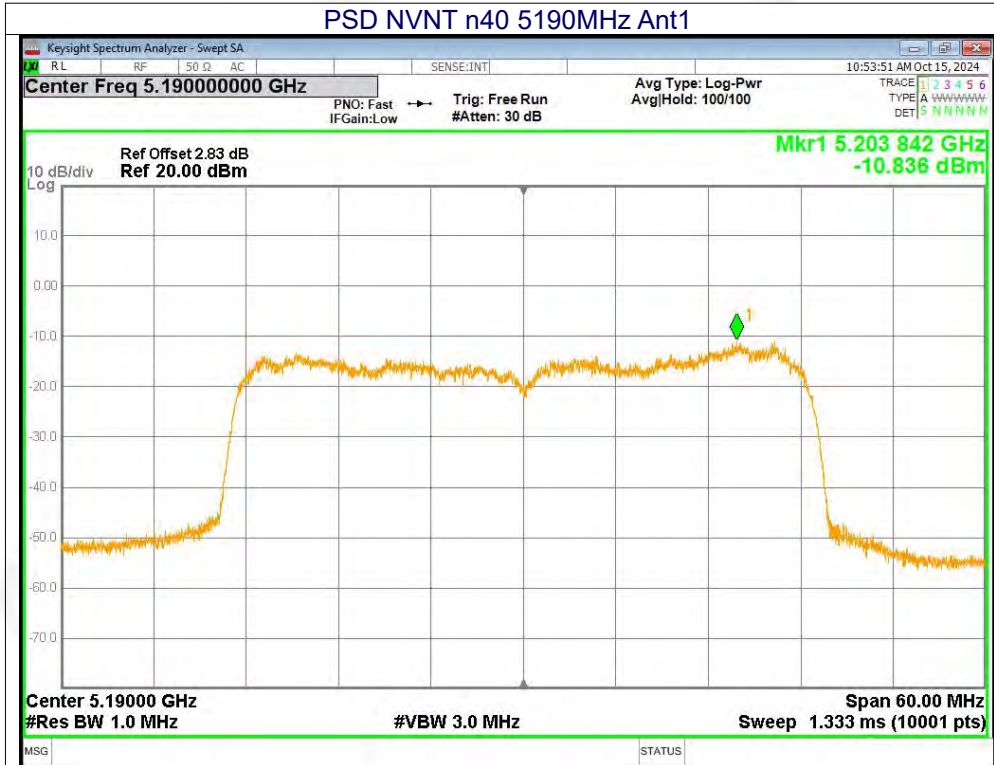

PSD NVNT n40 5230MHz Ant1

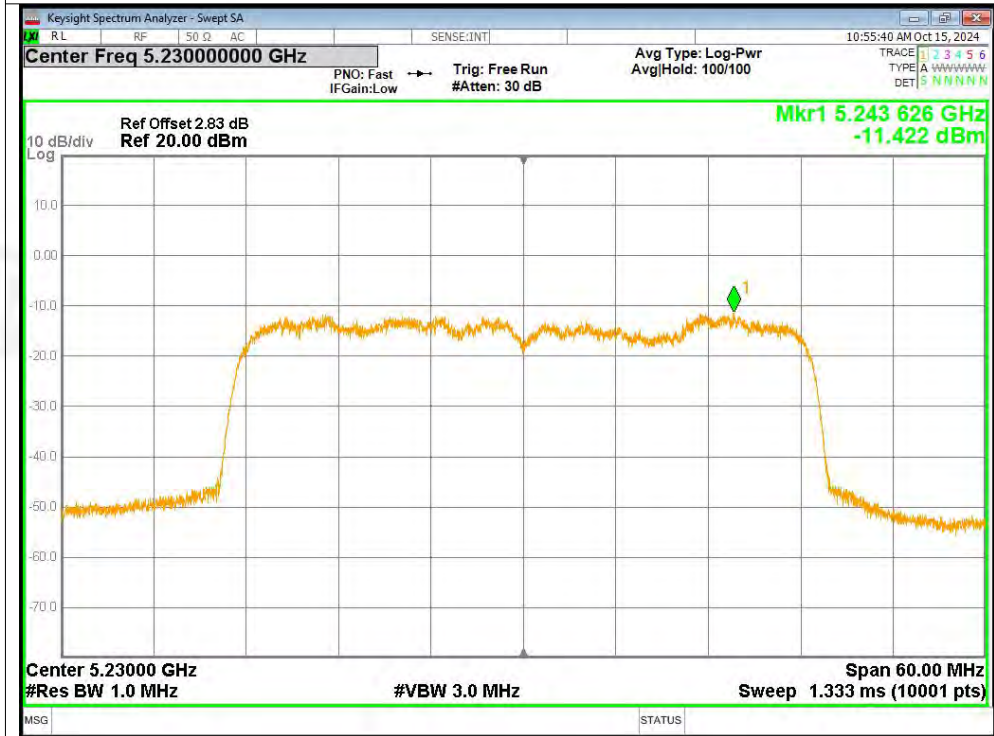



PSD NVNT ac20 5180MHz Ant1

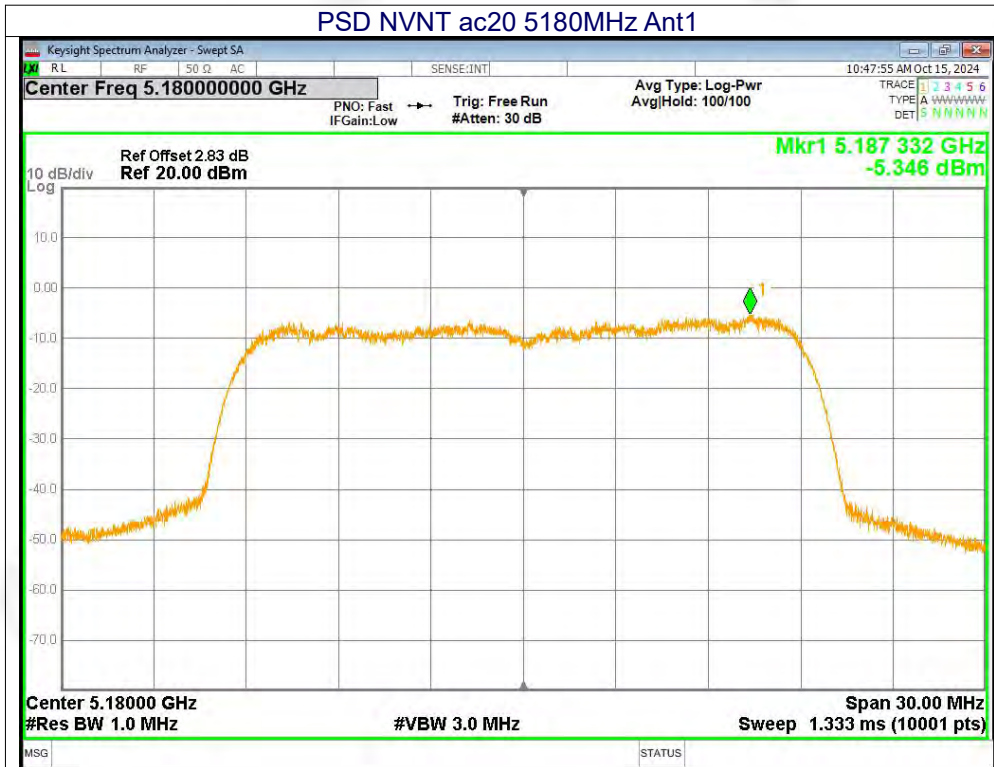

PSD NVNT ac20 5200MHz Ant1

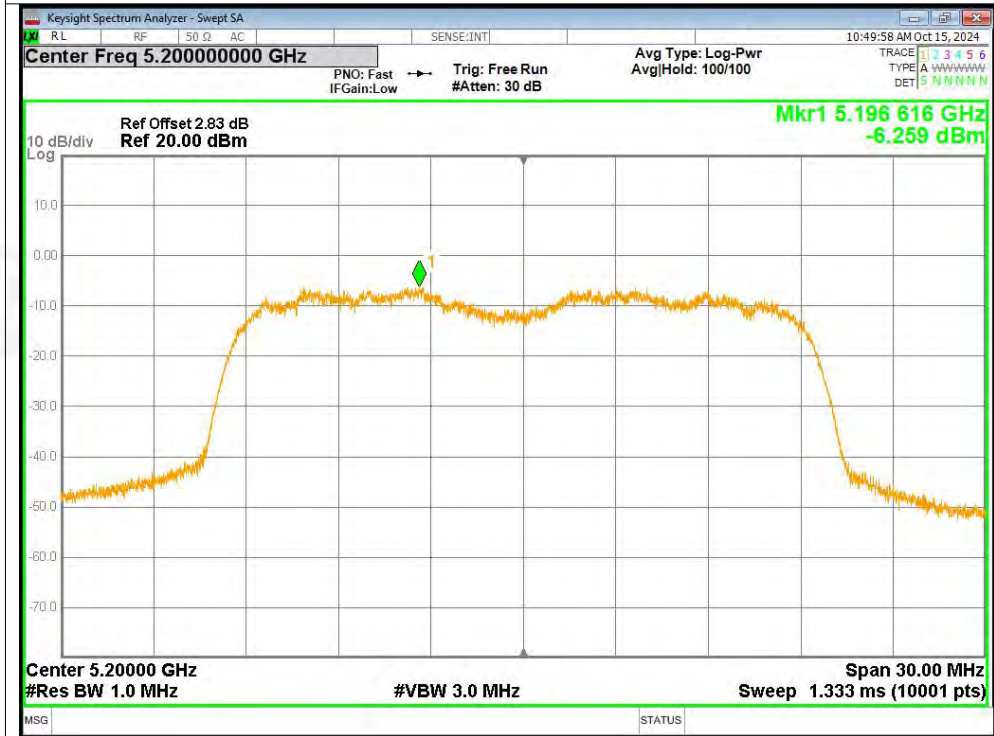

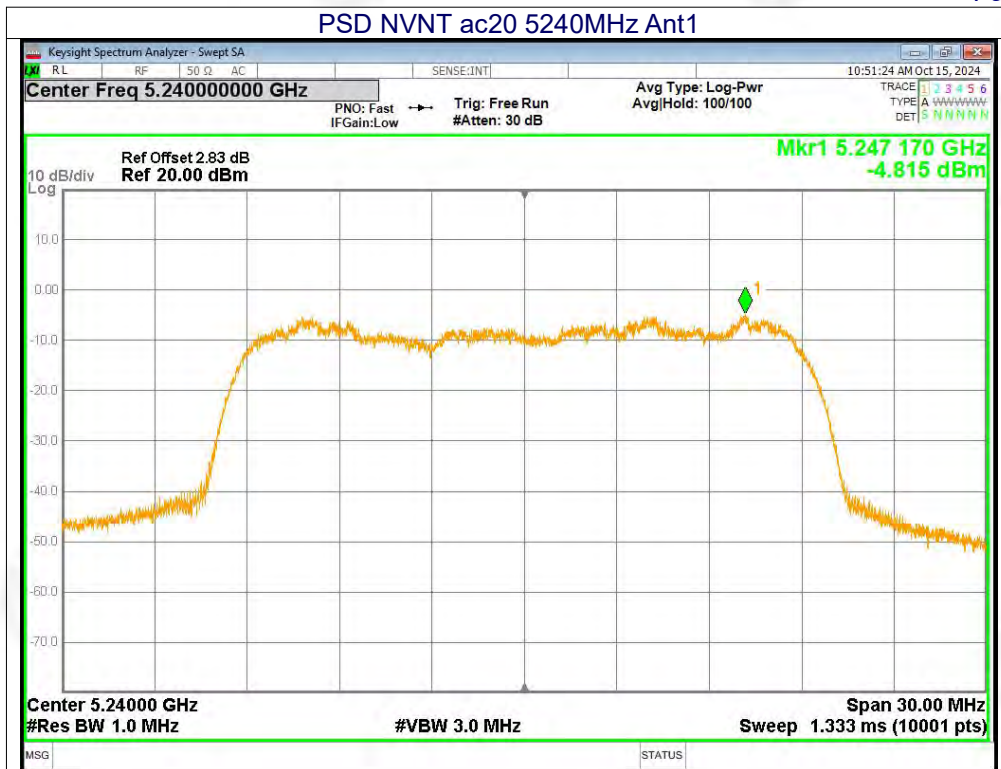





A.3 -26dB Bandwidth

Mode	Frequency (MHz)	-26 dB Bandwidth (MHz)	Verdict
a	5180	21.006	Pass
a	5200	20.242	Pass
a	5240	20.271	Pass
n20	5180	20.502	Pass
n20	5200	20.865	Pass
n20	5240	20.763	Pass
n40	5190	41.353	Pass
n40	5230	41.756	Pass
ac20	5180	20.904	Pass
ac20	5200	20.852	Pass
ac20	5240	20.605	Pass
ac40	5190	41.257	Pass
ac40	5230	41.764	Pass
ac80	5210	80.838	Pass