

承 認 書

SPECIFICATION FOR APPROVAL

客 戶:
CUSTOMER: _____

客 戶 料 號:
CUST P/N: _____

淘 软 料 號:
BESOFTP/N: _____

產 品 型 號:
DESC: _____

日 期:
DATE: **2024/08/12**

版 本:
Version: **A.0**

擬 制 PREPARED BY	審 核 CHECKED BY	批 准 APPROVED BY	客 戶 承 認 CUSTOMER APPROVE
Duke Feng	Jack Su	Sam Qi an	

Shenzhen Taoruan Electronics Co., Ltd.
Factory address: Room 702, Building 1, Shangshijia Old Village, Shijia Community, Matan Street, Guangming District, Shenzhen

TEL: 13824883512

SPECIFICATION

產品型號: DESC	DE257CLB	版本 Rev: A 0	客戶 CUST: 淘软料号 Fine P/N: 客户料号 CUST P/N:	
---------------	-----------------	----------------	----------------------------------------------	--

一、尺寸 DIMENSION:(mm)

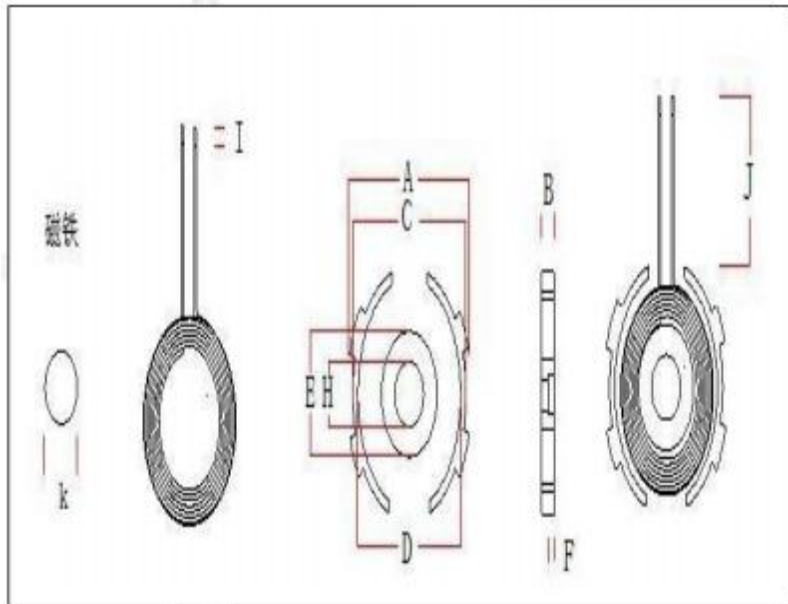

A	25±0.5
B	2.5±0.2
C	23.7±0.25
D	20.5±1
E	15±0.3
H	7.8±0.3
I	3±1
J	8±2
K	7.8*2.0

二、原理图SCHEMATIC DIAGRAM:



三、绕线参数 Winding Specification:

序号 NO	端子 TERMINAL	线径 WIRE	圈数 Turns	绕线方向 Winding Direction
1	S F	热风线 0.08*24P	12TS	正常

四、电气特性 ELECTRICAL CHARACTERISTICS:

温度 TEMPERATURE:25 ±10°C, 湿度 RELATIVE HUMIDITY:65 ±20%

序号 NO.	项目 ITEM	端子 TERMINAL	标准 SPECIFICATION	测试条件 TEST FREQUENCY	测试仪器 TEST EQUIPMENTS
1	IND.	S-F	3.8uH ±20%单独线圈	100KHz/1V	LCZ METER 1062B
2	IND.	S-F	6.8uH±10 %	100KHz/1V	LCZ METER 1062B
3	Q 值	S-F	≥30	100KHz/1V	LCZ METER 1062B
4	DCR	S-F	260MAX		

拟制/日期 PREPARED BY/DATE Duke Feng 2024/08/12	审核/日期 CHECKED BY/DATE Jack Su 2024/08/12
------------------------------------------------	---------------------------------------------