



FCC TEST REPORT

For

Edizard Co. LTD

Wireless Power Bank

Test Model: EZ810201

Prepared for : Edizard Co. LTD
Address : Room 405, No.5 Building, Dingfeng Technology Park, Shayi Community, Shajing Town, Bao'an District, Shenzhen, Guangdong Province, China, 518104.

Prepared by : Shenzhen LCS Compliance Testing Laboratory Ltd.
Address : 101, 201 Bldg A & 301 Bldg C, Juji Industrial Park Shajing Street, Baoan District, Shenzhen, China
Tel : (+86)755-82591330
Fax : (+86)755-82591332
Web : www.LCS-cert.com
Mail : webmaster@LCS-cert.com

Date of receipt of test sample : September 05, 2024
Number of tested samples : 2
Sample No. : A240826108-1(Engineer sample), A240826108-2(Normal sample)
Date of Test : September 05, 2024 ~ September 23, 2024
Date of Report : September 24, 2024





FCC TEST REPORT	
KDB 680106 D01 Wireless Power Transfer v04	
Report Reference No.	LCSA08124222EB
Date of Issue	September 24, 2024
Testing Laboratory Name	Shenzhen LCS Compliance Testing Laboratory Ltd.
Address	101, 201 Bldg A & 301 Bldg C, Juji Industrial Park Shajing Street, Baoan District, Shenzhen, China
Testing Location/ Procedure	Full application of Harmonised standards <input checked="" type="checkbox"/> Partial application of Harmonised standards <input type="checkbox"/> Other standard testing method <input type="checkbox"/>
Applicant's Name	Edizard Co. LTD
Address	Room 405, No.5 Building, Dingfeng Technology Park, Shayi Community, Shajing Town, Bao'an District, Shenzhen, Guangdong Province, China, 518104.
Test Specification	
Standard	FCC CFR 47 PART 1, § 1.1310 KDB 680106 D01 Wireless Power Transfer v04
Test Report Form No.	LCSEMC-1.0
TRF Originator	Shenzhen LCS Compliance Testing Laboratory Ltd.
Master TRF	Dated 2023-12
Shenzhen LCS Compliance Testing Laboratory Ltd. All rights reserved.	
This publication may be reproduced in whole or in part for non-commercial purposes as long as the Shenzhen LCS Compliance Testing Laboratory Ltd. is acknowledged as copyright owner and source of the material. Shenzhen LCS Compliance Testing Laboratory Ltd. takes no responsibility for and will not assume liability for damages resulting from the reader's interpretation of the reproduced material due to its placement and context.	
EUT Description	Wireless Power Bank
Trade Mark	N/A
Test Model	EZ810201
Ratings	Input: Type-C: 5V $\overline{=}$ 3A, 9V $\overline{=}$ 2A Output: Type-C: 5V $\overline{=}$ 3A, 9V $\overline{=}$ 2.22A, 12V $\overline{=}$ 1.67A Total Output: 5V $\overline{=}$ 3A, 15W Max Wireless: 5W, 7.5W, 15W Max DC 3.8V by Rechargeable Li-ion Battery, 10000mAh
Result	Positive

Compiled by:

Supervised by:

Approved by:



Shenzhen LCS Compliance Testing Laboratory Ltd.
 Add: 101, 201 Bldg A & 301 Bldg C, Juji Industrial Park Yabianxueziwei, Shajing Street, Baoan District, Shenzhen, 518000, China
 Tel: +(86) 0755-82591330 | E-mail: webmaster@lcs-cert.com | Web: www.lcs-cert.com
 Scan code to check authenticity



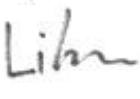

立讯检测
LCS Testi

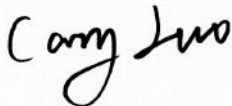
Li Huan/Administrator

立讯检测
LCS Testir

Cary Luo/ Technique principal

立讯检测股份
LCS Testing La

Gavin Liang/ Manager

立讯检测股份
LCS Testing Lab

立讯检测股份
LCS Testing Lab

立讯检测股份
LCS Testing Lab

立讯检测股份
LCS Testing Lab

立讯检测股份
LCS Testing Lab

立讯检测股份
LCS Testing Lab

立讯检测股份
LCS Testing Lab

立讯检测股份
LCS Testing Lab

立讯检测股份
LCS Testing Lab

立讯检测股份
LCS Testing Lab

立讯检测股份
LCS Testing Lab

立讯检测股份
LCS Testing Lab

立讯检测股份
LCS Testing Lab

立讯检测股份
LCS Testing Lab





ISED -- TEST REPORT

Test Report No. :	LCSA08124222EB	<u>September 24, 2024</u> Date of issue
--------------------------	-----------------------	--

Test Model.....	: EZ810201
EUT.....	: Wireless Power Bank
Applicant.....	: Edizard Co. LTD
Address.....	: Room 405, No.5 Building, Dingfeng Technology Park, Shayi Community, Shajing Town, Bao'an District, Shenzhen, Guangdong Province, China, 518104.
Telephone.....	:
Fax.....	:
Manufacturer.....	: Shenzhen Joway Power Supply Co., Ltd.
Address.....	: Blog 10th & 11th, Antuoshan High-Tech Industrial Park, Shajing Street, Shenzhen China
Telephone.....	:
Fax.....	:
Factory.....	: Shenzhen Joway Power Supply Co., Ltd.
Address.....	: Blog 10th & 11th, Antuoshan High-Tech Industrial Park, Shajing Street, Shenzhen China
Telephone.....	:
Fax.....	:

Test Result	Positive
--------------------	-----------------

The test report merely corresponds to the test sample.

It is not permitted to copy extracts of these test result without the written permission of the test laboratory.





Revision History

Revision	Issue Date	Revisions	Revised By
000	September 24, 2024	Initial Issue	--





TABLE OF CONTENTS

1. GENERAL INFORMATION 7

1.1. DESCRIPTION OF DEVICE (EUT)7

1.2. SUPPORT EQUIPMENT LIST7

1.3 EXTERNAL I/O CABLE 7

1.4. DESCRIPTION OF TEST FACILITY 7

1.5. TEST EQUIPMENT 7

1.6. MEASUREMENT UNCERTAINTY 8

1.7. DESCRIPTION OF TEST MODES 8

1.8. COIL DESCRIPTION 8

1.9. COIL SIZE 8

1.10. COIL SPECIFICATIONS 9

1.11. DUTY CYCLE 9

2. TEST METHODOLOGY 10

2.1. REFERENCE EVALUATION METHOD 10

2.2. LIMIT 10

2.3. TEST SETUP DIAGRAM 11

2.4. MEASUREMENT PROCEDURE 12

2.5. EQUIPMENT APPROVAL CONSIDERATIONS OF KDB 680106 D01V04 12

3. TEST RESULTS 13

3.3 CONCLUSION 16

4. TEST SETUP PHOTOS 17





1. GENERAL INFORMATION

1.1. Description of Device (EUT)

EUT : Wireless Power Bank

Test Model : EZ810201

Ratings : Input: Type-C: 5V==3A, 9V==2A
 Output: Type-C: 5V==3A, 9V==2.22A, 12V==1.67A
 Total Output: 5V==3A, 15W Max
 Wireless: 5W, 7.5W, 15W Max
 DC 3.8V by Rechargeable Li-ion Battery, 10000mAh

Hardware Version : V3.0

Software Version : V3.0

Wireless Charging :

Operating Frequency : 110.0~205.0KHz

Modulation Type : ASK

Antenna Type : Coil Antenna

1.2. Support equipment List

Manufacturer	Description	Model	Serial Number	Certificate
HONOR	Phone	V30Pro	---	FCC
SHENZHEN TIANYIN ELECTRONICS CO., LTD	Power Adapter	TPA-46050200UU	---	FCC

Note: Auxiliary equipment is provided by the laboratory.

1.3 External I/O Cable

I/O Port Description	Quantity	Cable
Type-C USB Port	1	N/A

1.4. Description of Test Facility

NVLAP Accreditation Code is 600167-0.
 FCC Designation Number is CN5024
 CAB identifier is CN0071.
 CNAS Registration Number is L4595.
 Test Firm Registration Number: 254912.
 The 3m-Semi anechoic test site fulfils CISPR 16-1-4 according to ANSI C63.4:2014 and CISPR 16-1-4:2010 SVSWR requirement for radiated emission above 1GHz.

1.5. Test Equipment

Equipment	Manufacturer	Model	Serial no.	Calibrated date	Calibrated Due
Exposure Level Tester	Narda	ELT-400	N-0713	2023-10-18	2024-10-17
B-Field Probe	Narda	100cm ²	M-1154	2023-10-18	2024-10-17

Exposure Level Tester ELT-400 detailed parameters are as follows:





Common parameter	
Operating temperature	-10 °C ~ +50 °C
Operation humidity	< 95 % (30 °C) or < 29 g/m ³
Weight	910 g
Size	180 mm x 100 mm x 55 mm(Main engine) / 290 mm x 125 mm Ø (Probe)
Display	LCD backlit display, 4 refresh rates per second
Battery	Nimh battery (4 x Mignon, AA), rechargeable
Operating time, typical	12 h
Power supply	100 ~240 V AC / 47 ~ 63 Hz
Charging time, typical	2 hours
Recommended calibration cycle	24 months
Country of origin	Germany

1.6. Measurement Uncertainty

Test Item	Frequency Range	Uncertainty	Note
Field Strength Uncertainty	1Hz~400KHz	1%	(1)

(1). This uncertainty represents an expanded uncertainty expressed at approximately the 95% confidence level using a coverage factor of k=2.

1.7. Description of Test Modes

Equipment under test was operated during the measurement under the following conditions:

Charging and communication mode

Test Modes		
Mode 1	AC/DC Adapter(5V/3A)+EUT+mobile phone (Battery Status: <1%)	Record
Mode 2	AC/DC Adapter(5V/3A)+EUT+mobile phone (Battery Status: <50%)	Record
Mode 3	AC/DC Adapter(5V/3A)+EUT+mobile phone (Battery Status: 100%)	Record
Mode 4	AC/DC Adapter(9V/2.22A)+EUT+mobile phone (Battery Status: <1%)	Pre-tested
Mode 5	AC/DC Adapter(9V/2.22A)+EUT+mobile phone (Battery Status: <50%)	Pre-tested
Mode 6	AC/DC Adapter(9V/2.22A)+EUT+mobile phone (Battery Status: 100%)	Pre-tested
Mode 7	AC/DC Adapter(12V/1.67A)+EUT+mobile phone (Battery Status: <1%)	Pre-tested
Mode 8	AC/DC Adapter(12V/1.67A)+EUT+mobile phone (Battery Status: <50%)	Pre-tested
Mode 9	AC/DC Adapter(12V/1.67A)+EUT+mobile phone (Battery Status: 100%)	Pre-tested

Note: All test modes were pre-tested for ac and dc mode, but we only recorded the worst case in this report for ac mode.

1.8. Coil Description

Config.	Mode	Descriptions
1	Standby (Flatbed Position) @134kHz	EUT Alone powered by AC/DC adapter
2	Operating (Flatbed Position) (Phone @134kHz, ~10%, 20~50%, and >75% Power Charging)	EUT with lightning to AC/DC Adapter & Wireless Charging to WPT Client. 15W: Direct Contact 15W: 2mm Airgap, 2mm Shift Top as Worst-Case Position

1.9. Coil Size



Shenzhen LCS Compliance Testing Laboratory Ltd.

Add: 101, 201 Bldg A & 301 Bldg C, Juji Industrial Park Yabianxueziwei, Shajing Street, Baoan District, Shenzhen, 518000, China

Tel: +(86) 0755-82591330 | E-mail: webmaster@lcs-cert.com | Web: www.lcs-cert.com

Scan code to check authenticity

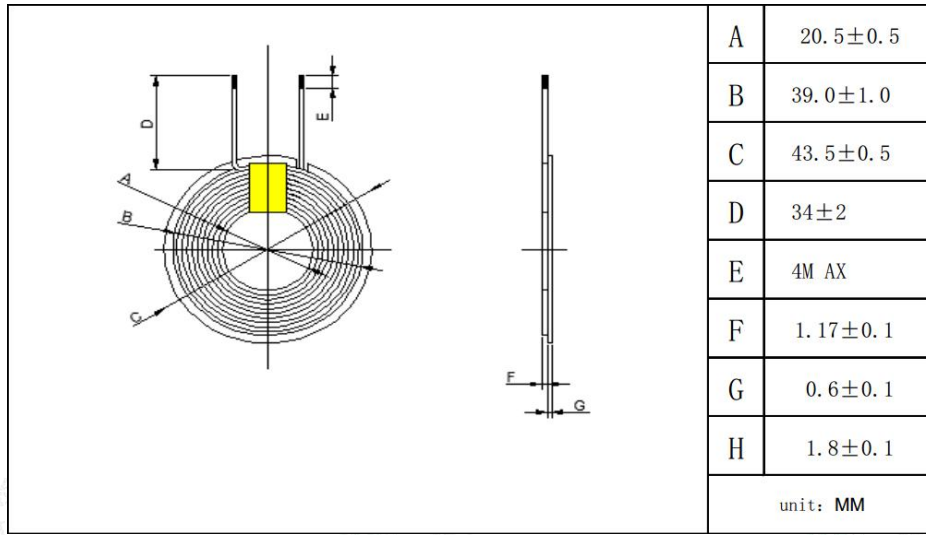

(Unit: mm)

1.10. Coil Specifications

Item	Parameter
Input inductance:	Transmitter 1: 6.5 μH±10%
Material of enclosure(s):	Multiple strands of enamelled wire
Number of turns:	Transmitter 1: 10 turns

1.11. Duty Cycle

Mode	ON Time (ms)	Period (ms)	Duty Cycle (%)
Operating (110.0-205kHz)	/	/	100

Operating (110.0~205.0KHz)



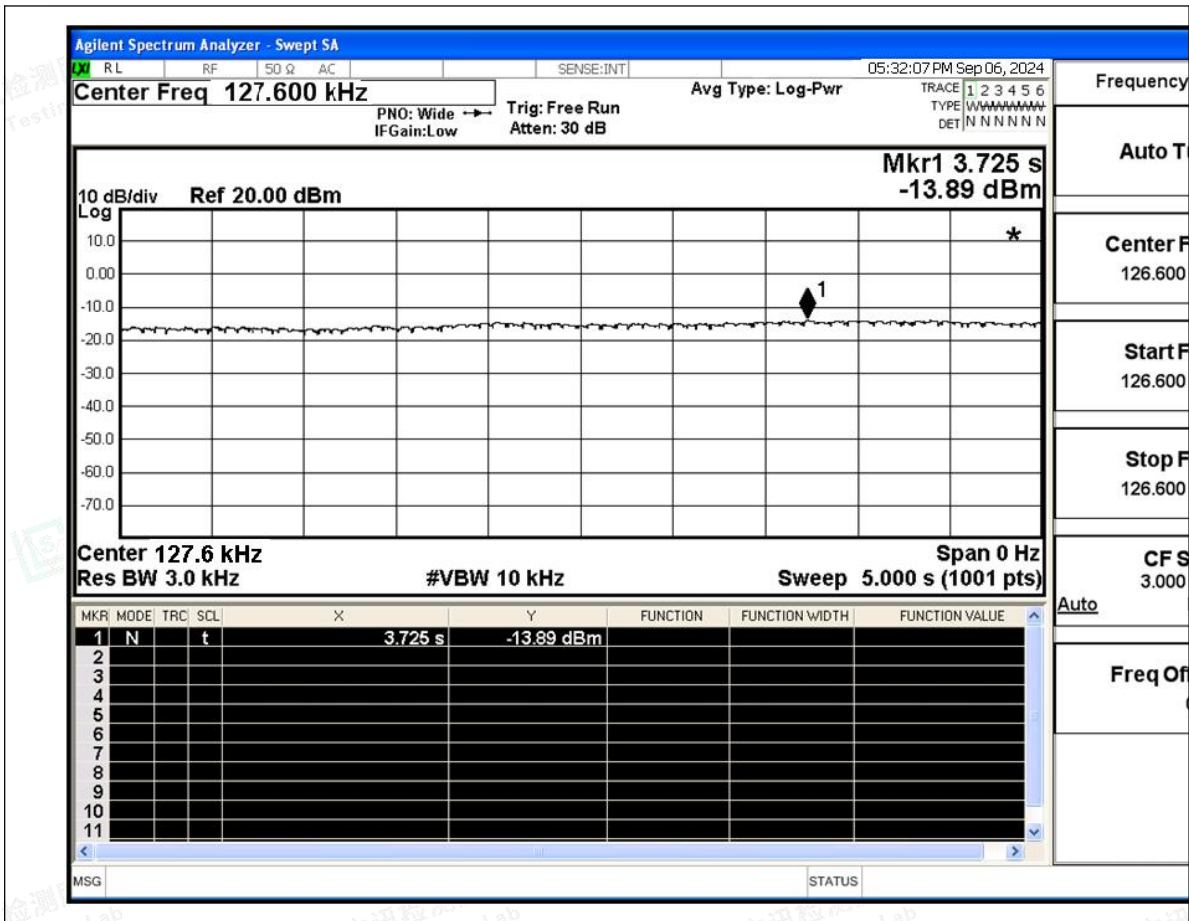

2. TEST METHODOLOGY

2.1. Reference Evaluation Method

ANSI C95.1–1999: IEEE Standard for Safety Levels with Respect to Human Exposure to Radio Frequency Electromagnetic Fields, 3 kHz to 300 GHz.

FCC KDB publication 680106 D01 RF Exposure Wireless Charging Apps v04: RF Exposure Considerations for Low Power Consumer Wireless Power Transfer Applications

FCC CFR 47 part1 1.1310: Radiofrequency radiation exposure limits.

FCC CFR 47 part2 2.1093: Radiofrequency radiation exposure evaluation: portable devices

FCC CFR 47 part 18.107: Industrial, Scientific, and Medical Equipment

April 2024 TCBC Workshop: Part 18 Wireless Power Transfer Devices: Clarifications on KDB 680106v04 and ECR Processes

2.2. Limit

§1.1310: The criteria listed in the following table shall be used to evaluate the environment impact of human exposure to radio frequency (RF) radiation as specified in §1.1307(b), except in the case of portable devices which shall be evaluated according to the provisions of FCC part 2.1093 of this chapter.

Table 1 to §1.1310(e)(1) - Limits for Maximum Permissible Exposure (MPE)

Frequency range (MHz)	Electric field strength (V/m)	Magnetic field strength (A/m)	Power density (mW/cm ²)	Averaging time (minutes)
(i) Limits for Occupational/Controlled Exposure				



0.3-3.0	614	1.63	*(100)	≤6
3.0-30	1842/f	4.89/f	*(900/f ²)	<6
30-300	61.4	0.163	1.0	<6
300-1500	/	/	f/300	<6
1500-100000	/	/	5	<6
imits fo(ii) Lir General Population/Uncontrolled Exposure				
0.3-1.34	614	1.63	*(100)	<30
1.34-30	824/f	2.19/f	*(180/f ²)	<30
30-300	27.5	0.073	0.2	<30
300-1500	/	/	f/1500	<30
1500-100000	/	/	1.0	<30

f = frequency in MHz

* = Plane-wave equivalent power density

Note 1: Occupational/controlled exposure limits apply in situations in which persons are exposed as a consequence of their employment provided those persons are fully aware of the potential for exposure and can exercise control over their exposure.

Note 2: General population/uncontrolled exposure limits apply in situations in which the general public may be exposed, or in which persons who are exposed as a consequence of their employment may not be fully aware of the potential for exposure or cannot exercise control over their exposure.

2.3. Test Setup Diagram

Mobile Exposure Conditions

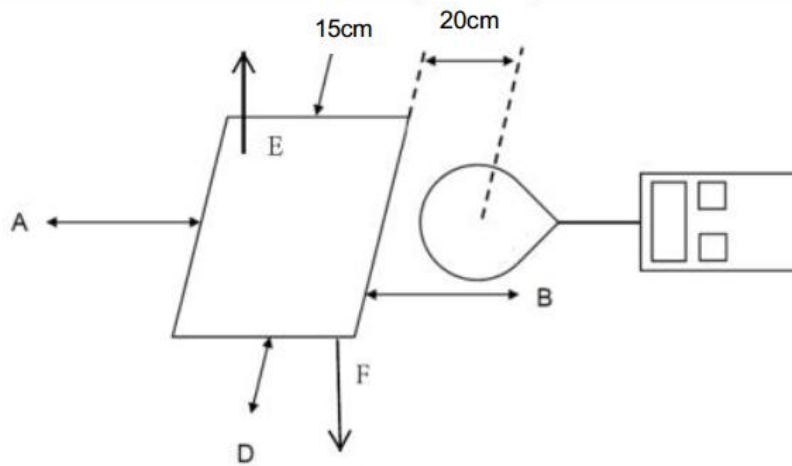

Note: The distance of the points A/B/C/D is 15cm, and the point E is 20cm.

Portable Exposure Conditions:



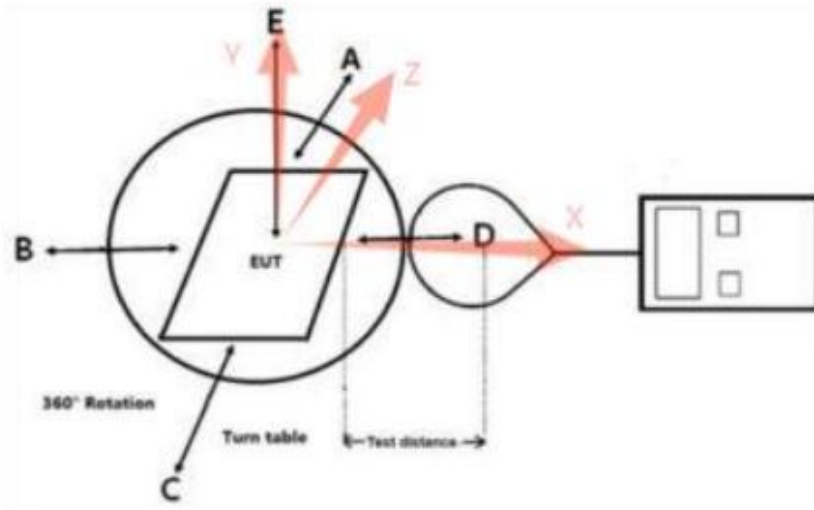

Note: The distance of the points A/B/C/D/E/F is 0,2,4,6,8,10,12,14,16,18, 20cm.

The values tested by the probe are X, Y, and Z on three axes perpendicular to the edge of the device. Top and bottom side coincident with the axis(Y) of the main coil.

2.4. Measurement Procedure

Mobile Exposure Conditions

- The RF exposure test was performed in anechoic chamber.
- E and H-field measurements should be made with the center of the probe at 15 cm surrounding the EUT and 20 cm above the top surface of the primary/client pair.
- The highest emission level was recorded and compared with limit.
- The EUT was measured according to the KDB 680106 D01 Wireless Power Transfer v04.

Portable Exposure Conditions

- The RF exposure test was performed in anechoic chamber.
- Perform H-field measurements for each edge/top surface of the host/client pair at every 2 cm, starting from as close as possible out to 20 cm
- The highest emission level was recorded and compared with limit.
- The EUT was measured according to the KDB 680106 D01 Wireless Power Transfer v04.

2.5. Equipment Approval Considerations of KDB 680106 D01v04

Requirements of KDB 680106 D01	Yes / No	Description
Power transfer frequency is less than 1 MHz	Yes	The device operates in the frequency range 110 KHz-205KHz
The output power from each transmitting element (e.g., coil) is less than or equal to 15 watts.	Yes	The maximum output power of each primary coil is 15W.
A client device providing the maximum permitted load is placed in physical contact with the transmitter (i.e., the surfaces of the transmitter and client device enclosures need to be in physical contact)	Yes	Client device is placed directly in contact with the transmitter.
Only § 2.1091- Mobile exposure conditions apply (i.e., this provision does not cover § 2.1093-Portable exposure conditions).	No	Mixed mobile and portable exposure conditions
The E-field and H-field strengths, at and beyond 20 cm surrounding the device surface, are demonstrated to be less than 50% of the applicable MPE limit, per KDB	Yes	The E-field and H-field strengths from all simultaneous transmitting coils are demonstrated to less than 50% of the MPE limit.



<p>447498, Table 1. These measurements shall be taken along the principal axes of the device, with one axis oriented along the direction of the estimated maximum field strength, and for three points per axis or until a 1/d (inverse distance from the emitter structure) field strength decay is observed. Symmetry considerations may be used for test reduction purposes. The device shall be operated in documented worst-case compliance scenarios (i.e., the ones that lead to the maximum field components), and while all the radiating structures (e.g., coils or antennas) that by design can simultaneously transmit are energized at their nominal maximum power.</p>		
<p>For systems with more than one radiating structure, the conditions specified in (5) must be met when the system is fully loaded (i.e., clients absorbing maximum power available), and with all the radiating structures operating at maximum power at the same time, as per design conditions. If the design allows one or more radiating structures to be powered at a higher level while other radiating structures are not powered, then those cases must be tested as well. For instance, a device may use three RF coils powered at 5 W, or one coil powered at 15 W: in this case, both scenarios shall be tested</p>	<p>Yes</p>	<p>Only one radiating structure and tested at maximum Output Power</p>

3. TEST RESULTS

For portable exposure condition

- (1). The portable test modes have covered the considerations of the mobile test, only record the test data of the portable conditions in this report.
- (2) Operating modes with client device (1 %, 50%, 99% battery status of client device) have been test, only show the data of worst case of 1% battery status of client device.
- (3) Test performed with all the radiating structures operating at maximum power at the same time.
- (4) E-Filed and H-field measurements are taken along all three axes the device from 0cm~20cm in 2cm minimum increment for each edge surface of the host/client pair. If the center of the probe sensing element is more than 5mm from the probe outer edge, the field strengths need to be estimated for the positions that are not reachable.
- (5) Validation of Field Estimates
 - (a) If R is the probe radius and the probe tip is in contact with the coil, then the probe center is R cm from the coil surface as bellowing picture

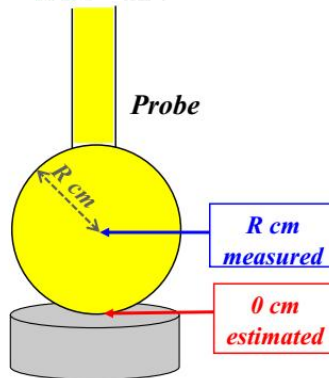

- (b) The probe then is measuring the field correctly at R cm from the surface, and only estimating the field at the 0 cm point of contact with the coil surface.



- (c) The validation requires showing that the model used to estimate the field provides data within 30% accuracy for at least the two, 2-cm-spaced closest points to where the estimates were made.
- (d) If there is only one estimated value, then a single validation point is sufficient.
- (e) Validation Example for 4 cm Probe Radius as following

Step 1

Validation Example for 4 cm Probe Radius

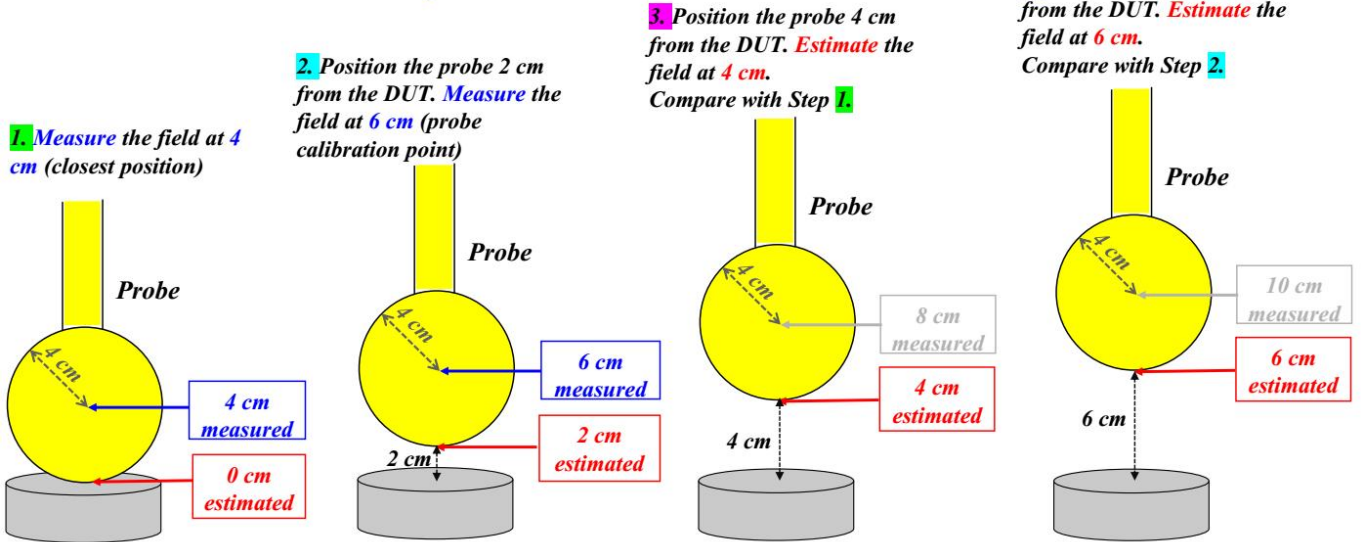

Step 2

Validation Example for 4 cm Probe Radius

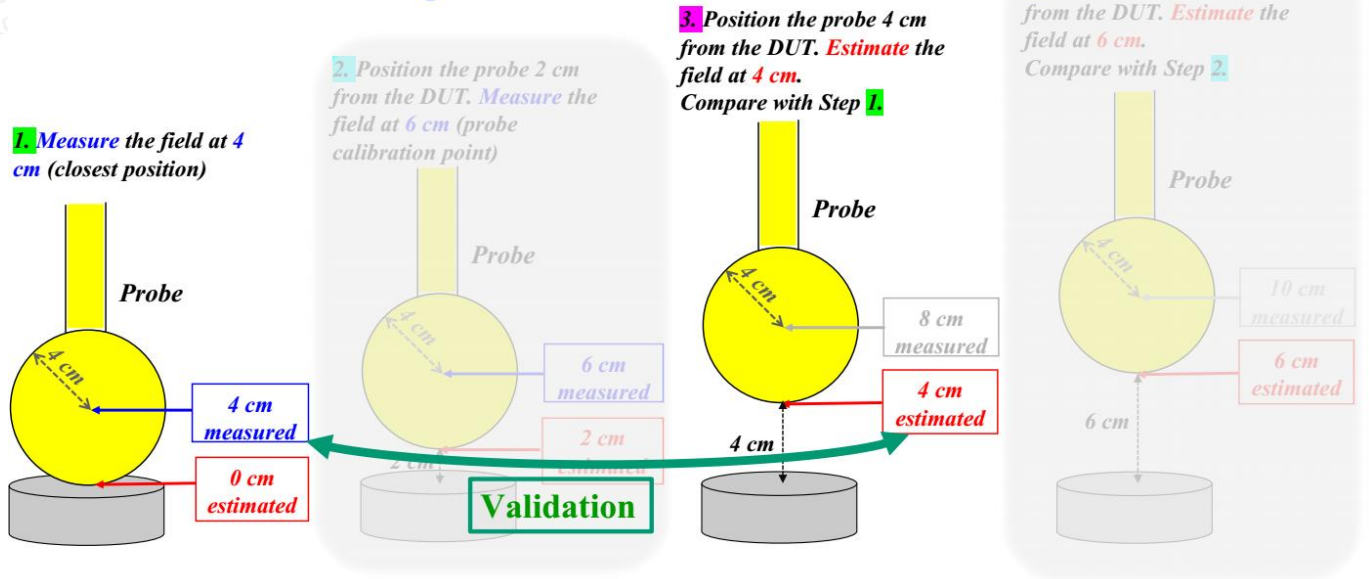

Step 3



Validation Example for 4 cm Probe Radius

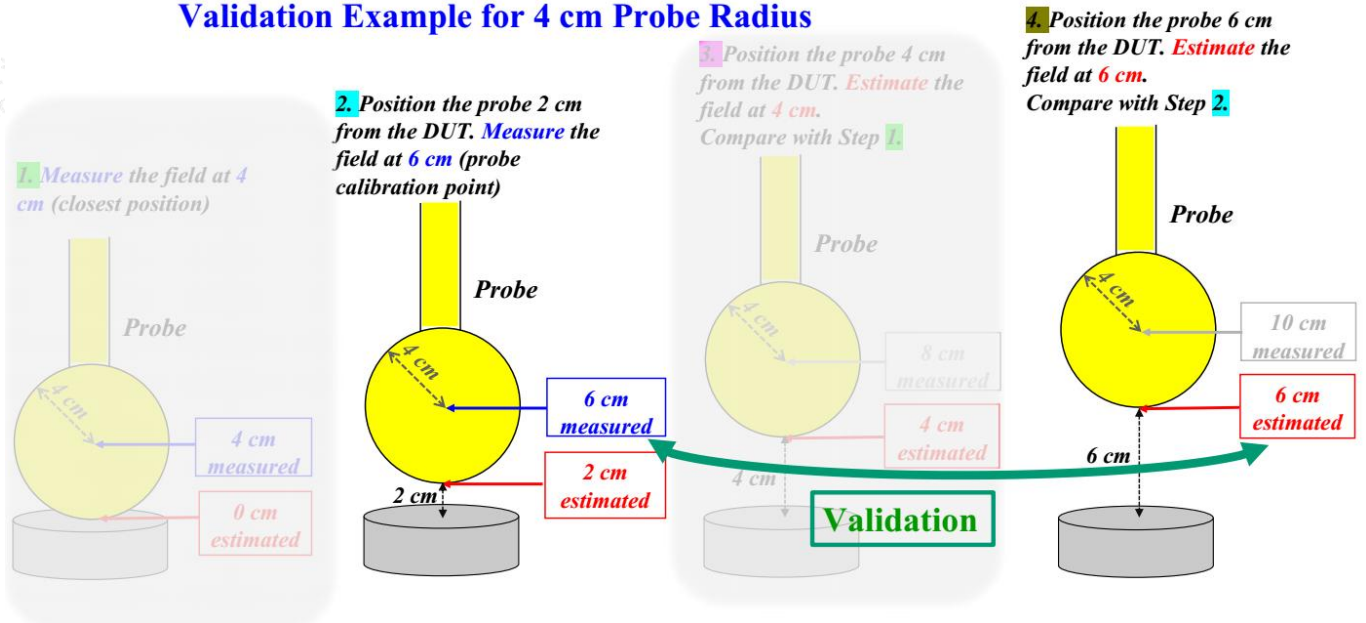

Description of the Validation Example for 4 cm Probe Radius

- Assume that $R=4$ cm. The field at 0 cm can only be estimated, but the field at 4 cm is measured exactly (at the center of the probe).
 - Move the probe at 2 cm from the surface. The field at 2 cm can still only be estimated, but the field at 6 cm is measured exactly.
 - Compare the estimates with the values at the same positions where the field was measured exactly (i.e., 4 cm and 6 cm)
 - The difference between measurements and estimates needs to be no more than 30%.
 - That validation of the estimates needs to be for the two closest points to the coil, but at least 2 cm apart (in this case they are). This is to avoid a validation at, say 2 cm and another one at 2.1 cm, that is essentially a repetition
- (6) According to Calibration information and specification about ETL-400 Probe (the B-Field Probe size is 100cm^2 , the probe radius is 5.65cm), The Probe ETL-400 Probe's sensitive elements center is located in the probe's center, and the distance from the sensitive elements center to the tip of probe is 5.65cm.
 - (7) The actual 0cm, 2cm, 4cm and 6cm field strengths need to be estimated for the positions that are not reachable via numerical calculation.
 - (8) For validation purposes: If the value to show a 30% agreement between the mode and the probe measurements for the two closest points to the device surface, and with 2cm increments. Then this extrapolation method is reasonable.
 - (9) Validation E-Field and H-Field as bellowing;

Validation Mode: TM1 H-Field (A/m)			Validation Position: Top	
	Results	Difference Values	Difference Limit	Conclusion
Estimated Distance: 0 cm	0.6726	28.87%	$\leq 30\%$	Compliance
Measured Distance: 5.65 cm	0.5219		$\leq 30\%$	Compliance
Estimated Distance: 2 cm	0.6122	29.32%	$\leq 30\%$	Compliance
Measured Distance: 7.65 cm	0.4734		$\leq 30\%$	Compliance
Estimated Distance: 4 cm	0.5438	25.62%	$\leq 30\%$	Compliance
Measured Distance: 7.65 cm	0.4329		$\leq 30\%$	Compliance

Validation Mode: TM1 E-Field (V/m)			Validation Position: Top	
	Results	Difference Values	Difference Limit	Conclusion





Estimated Distance: 0 cm	37.6345	27.24%	≤ 30%	Compliance
Measured Distance: 5.65 cm	29.5781		≤ 30%	Compliance
Estimated Distance: 2 cm	34.6318	27.98%	≤ 30%	Compliance
Measured Distance: 7.65 cm	27.0817		≤ 30%	Compliance
Estimated Distance: 4 cm	31.4018	29.84%	≤ 30%	Compliance
Measured Distance: 7.65 cm	23.5919		≤ 30%	Compliance

Note 1: The compliance location as probe tip;

Note 2: The format of difference is;

The E Validation Difference = $(E_{\text{Estimated Distance}} - E_{\text{Measured Distance}}) / E_{\text{Measured Distance}} * 100\%$

The H Validation Difference = $(H_{\text{Estimated Distance}} - H_{\text{Measured Distance}}) / H_{\text{Measured Distance}} * 100\%$

H-Field and E-Field Emission level with a combination of measured and estimated results.

Test condition: Mode 1

Distance(cm)	H-Field Result(A/m)							Limit(A/m)
	Type	Top	Bottom	Left	Right	Front	Back	
0	Estimate	0.7455	0.6655	0.5851	0.5812	0.4410	0.6004	1.63
2	Estimate	0.6965	0.5650	0.5722	0.4679	0.4864	0.3604	1.63
4	Estimate	0.5658	0.5570	0.6167	0.4918	0.3968	0.4947	1.63
6	Measured	0.3985	0.4880	0.3944	0.5105	0.2700	0.3397	1.63
8	Measured	0.2658	0.3409	0.2432	0.2378	0.3580	0.2496	1.63
10	Measured	0.0544	0.2769	0.1827	0.1296	0.0285	0.1130	1.63
12	Measured	0.1575	0.0934	0.1420	0.1594	0.0586	0.1059	1.63
14	Measured	0.1720	0.0724	0.1250	0.1469	0.0871	0.1439	1.63
16	Measured	0.1458	0.1129	0.1314	0.1004	0.1037	0.1727	1.63
18	Measured	0.0695	0.0613	0.0295	0.0020	0.0707	0.0845	1.63
20	Measured	0.1029	0.0601	0.1081	0.0230	0.0677	0.0411	1.63

Distance(cm)	E-Field Result(V/m)							Limit(V/m)
	Type	Top	Bottom	Left	Right	Front	Back	
0	Estimate	37.6742	36.2680	36.3754	32.0996	31.7683	31.5015	613
2	Estimate	34.5247	34.3174	34.0024	30.7030	29.6108	29.2392	613
4	Estimate	31.3050	30.7995	31.2441	27.9873	26.9488	26.6147	613
6	Measured	28.9040	26.8904	27.9636	23.7501	22.6798	22.3890	613
8	Measured	24.5444	23.2374	23.7629	20.5423	19.5777	19.2986	613
10	Measured	22.3124	21.2233	21.6986	17.5930	16.1905	16.1785	613
12	Measured	20.1628	19.4599	19.8043	15.3314	13.5249	13.1820	613
14	Measured	17.2955	17.0592	17.0598	13.1634	11.4115	11.1697	613
16	Measured	15.9300	14.8021	15.6211	10.2223	9.2233	9.1511	613
18	Measured	12.7005	11.6168	12.1745	8.3642	7.4423	7.3139	613
20	Measured	7.6955	7.4112	7.5923	5.2783	4.4125	3.9422	613

3.3 Conclusion

A minimum safety distance of 0 cm to the antenna is required when the device is charging a smart phone for portable exposure. The detected emissions are below the limitations according FCC KDB 680106.



Shenzhen LCS Compliance Testing Laboratory Ltd.

Add: 101, 201 Bldg A & 301 Bldg C, Juji Industrial Park Yabianxueziwei, Shajing Street, Baoan District, Shenzhen, 518000, China

Tel: +(86) 0755-82591330 | E-mail: webmaster@lcs-cert.com | Web: www.lcs-cert.com

Scan code to check authenticity



4. TEST SETUP PHOTOS

(The separation distance from the geometric center of the probe to the edge of the device is 6.25cm)





0cm-Left



0cm-Right



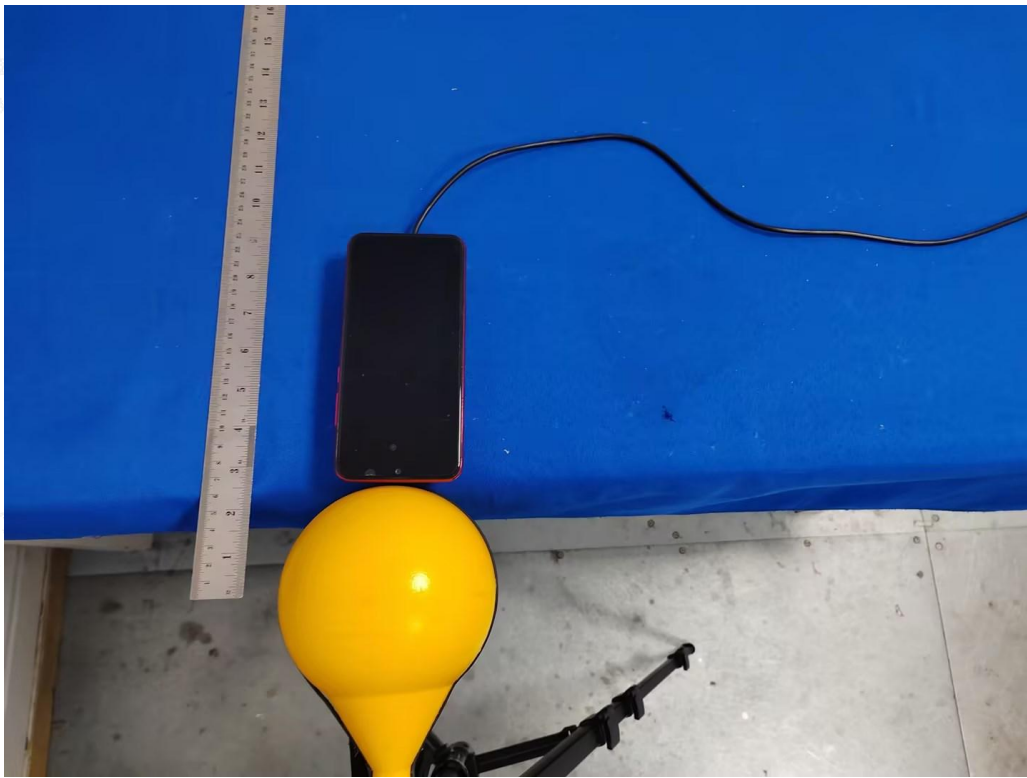

0cm-Top

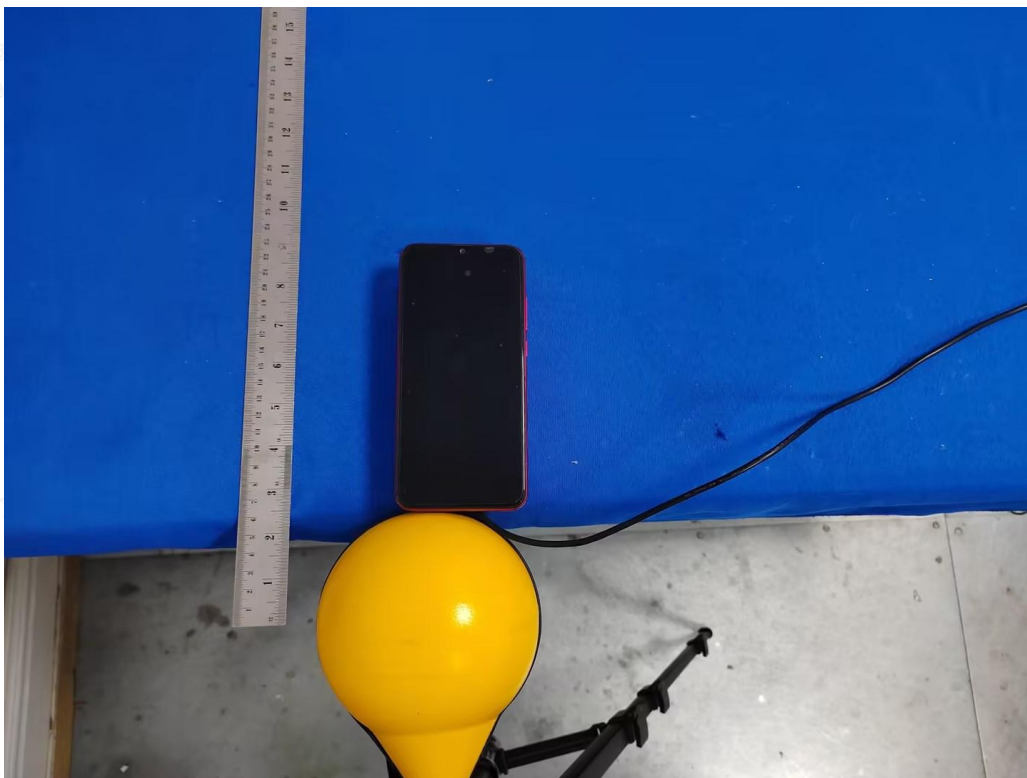

0cm-Bottom



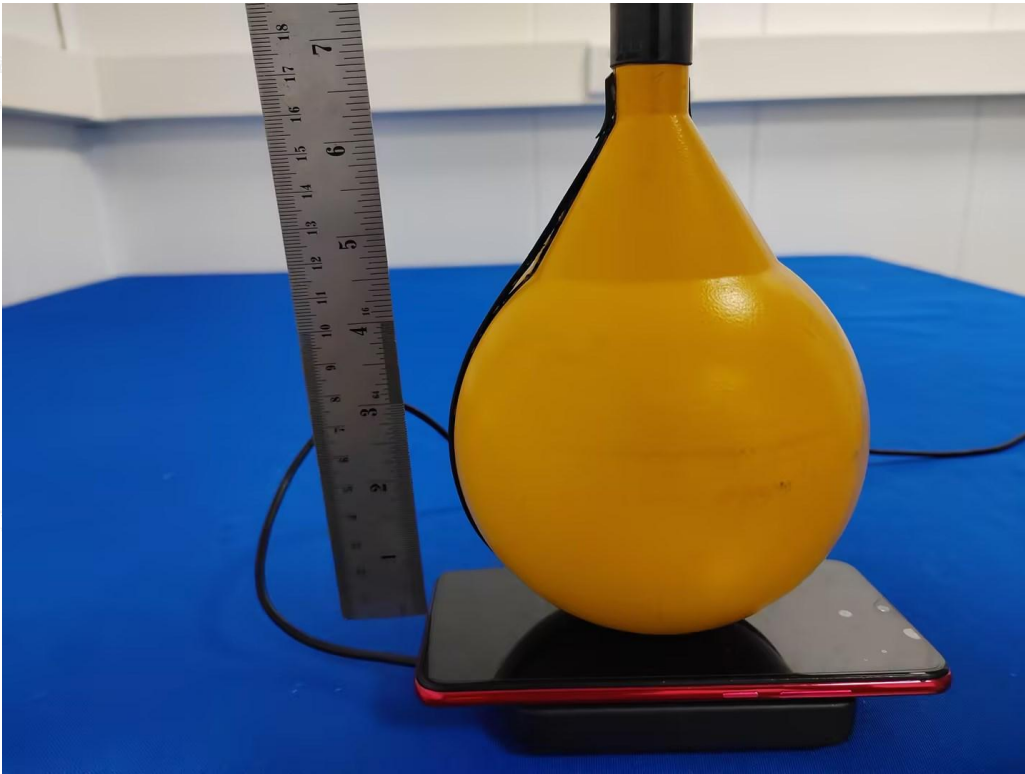

0cm-Front

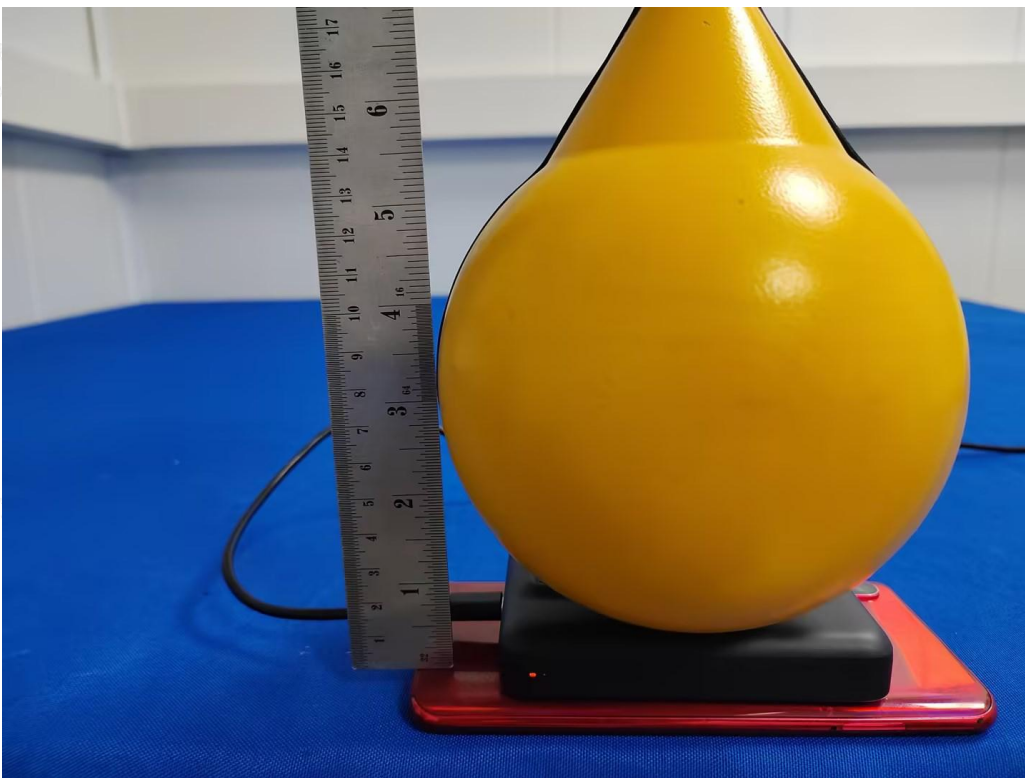

0cm-Back



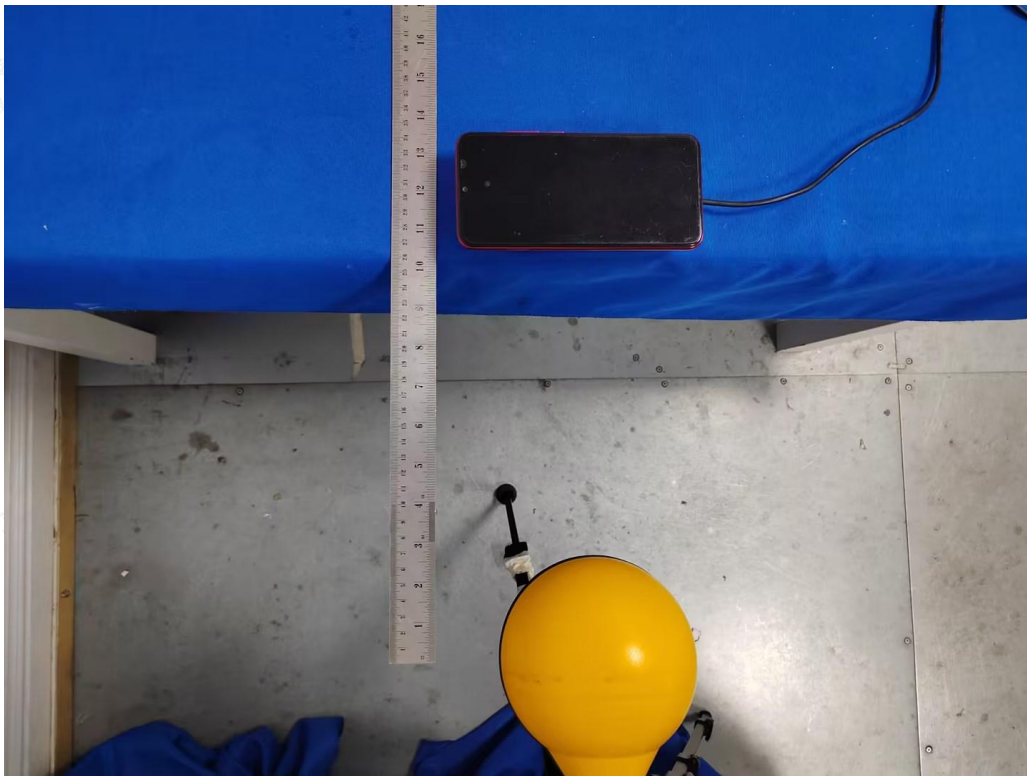

20cm-Left

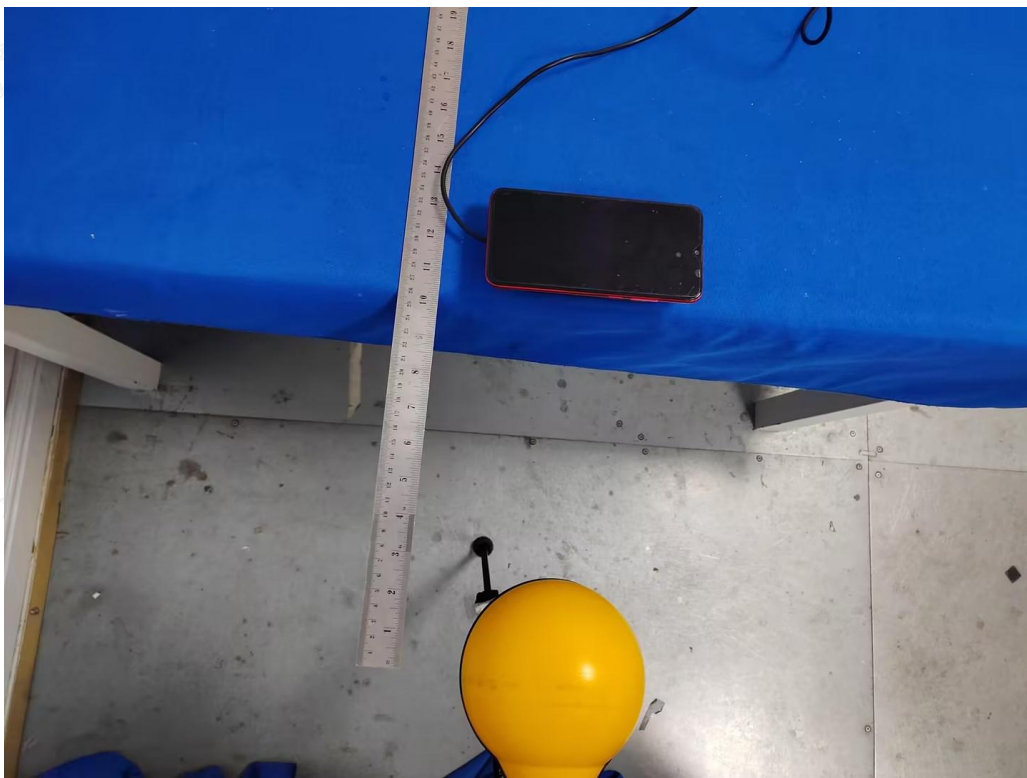

20cm-Right



Shenzhen LCS Compliance Testing Laboratory Ltd.

Add: 101, 201 Bldg A & 301 Bldg C, Juji Industrial Park Yabianxueziwei, Shajing Street, Baoan District, Shenzhen, 518000, China

Tel: +(86) 0755-82591330 | E-mail: webmaster@lcs-cert.com | Web: www.lcs-cert.com

Scan code to check authenticity

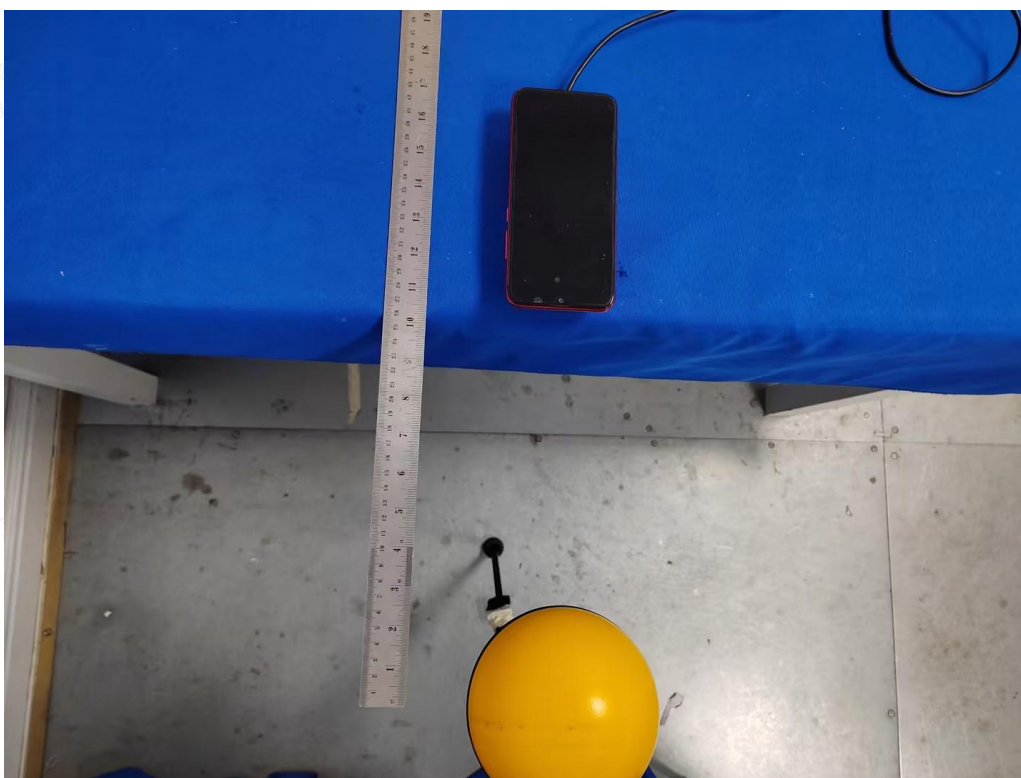

20cm-Top

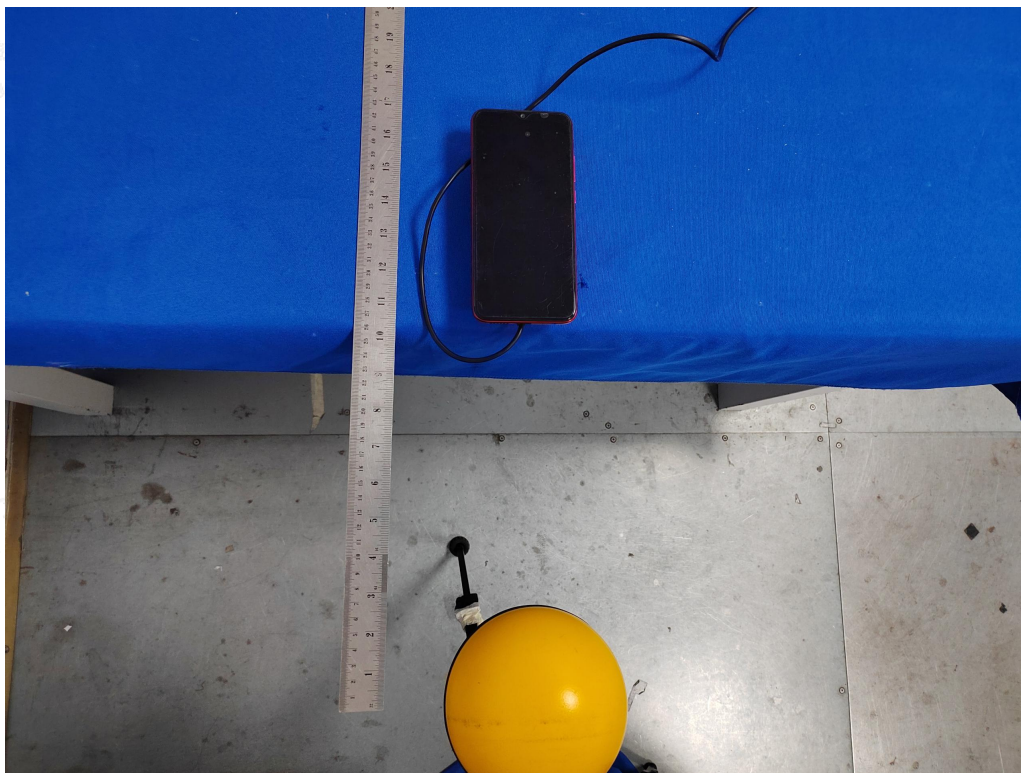

20cm-Bottom



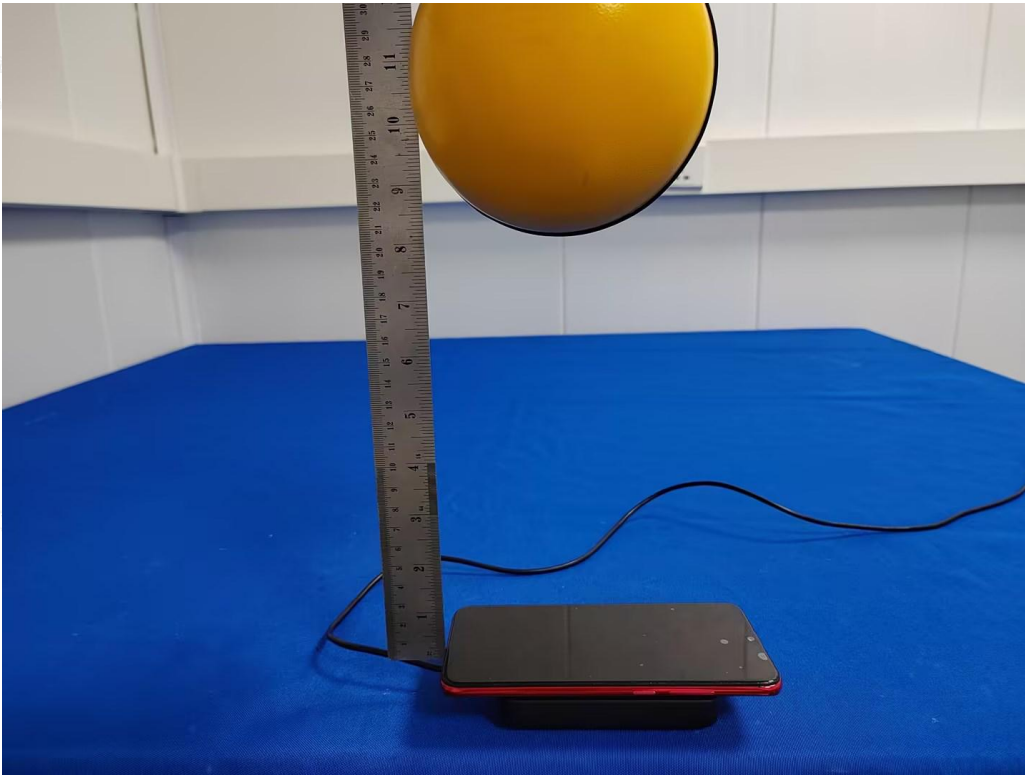

20cm-Front

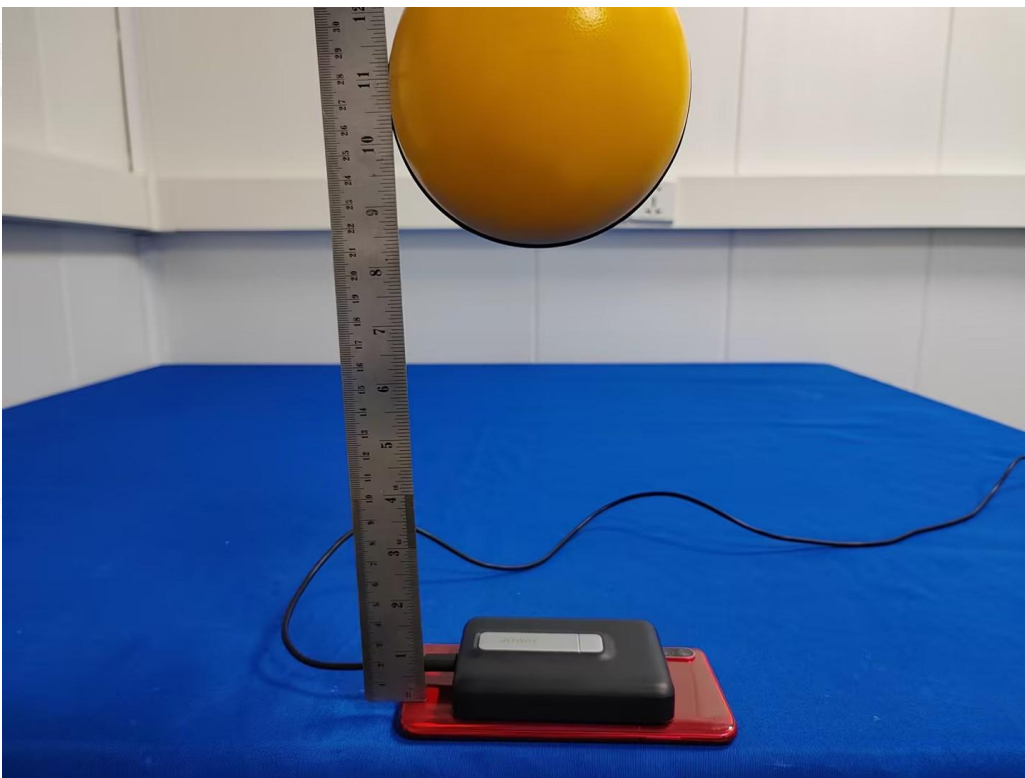

20cm-Back

-----THE END OF REPORT-----

