

FCC TEST REPORT

Report No...... NTC-ER2409047

Applicant's name..... Shenzhenshi Zhongzhimei Keji Youxiangongsi

Address..... 2D-227F,2nd Floor, Block 213, Tai Ran Science and
Technology Park, Tai Ran Sixth Road, Tian An
Community, Shatou Street, Futian District, Shenzhen,
China

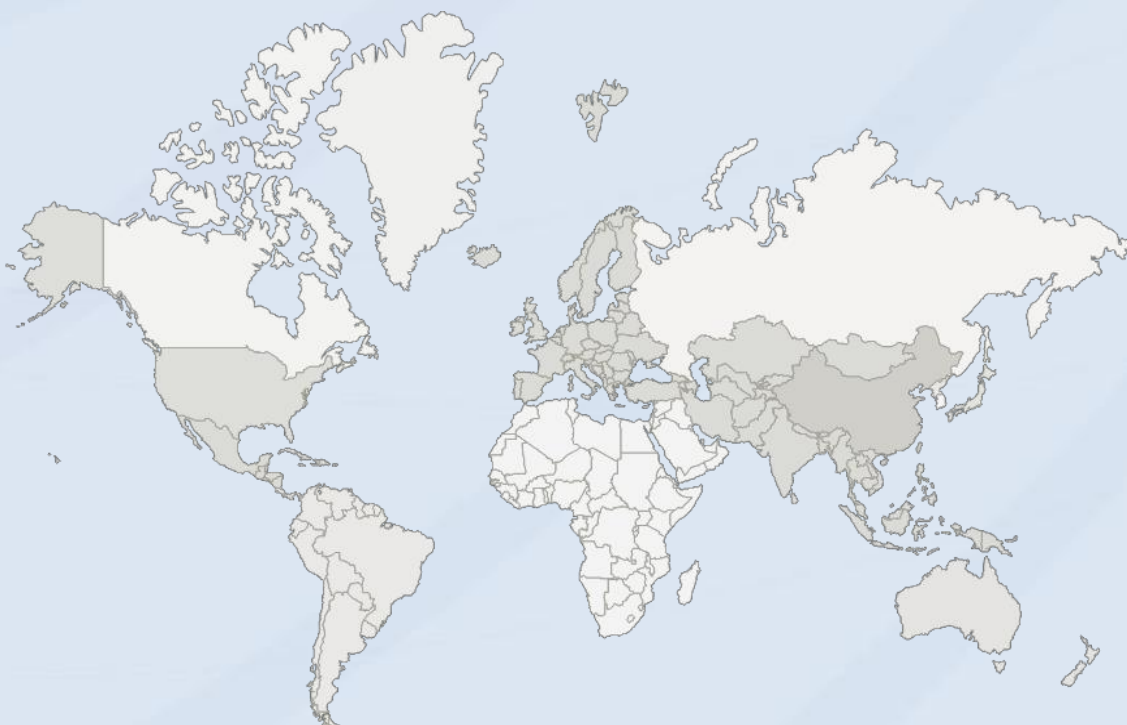

DONGGUAN NEW TESTING CENTRE CO., LTD

Ⓒ Address: 31F & 3F, No. 1 the 1st North Industry Road Songshan Lake Science & Technology Park Dongguan, People's Republic of China 523808

☎ Tel: +86-769-22212079

🌐 Web: <http://www.ntc-cert.com>

✉ E-mail: dave@ntc-cert.com

TABLE OF CONTENTS

TEST REPORT DECLARE	3
1. Summary of test results	4
2. General test information	4
2.1. Detail models.....	5
2.2. Test Peripheral List	6
2.3. Block diagram EUT configuration for test	6
2.4. Test environment conditions	6
2.5. Measurement uncertainty.....	6
3. Power Line Conducted Emission Test.....	7
3.1. Test equipment	7
3.2. Block diagram of test setup.....	7
3.3. Power Line Conducted Emission Limits (Class B)	7
3.4. Test Procedure	8
3.5. Test Result.....	8
4. Radiated emission test.....	11
4.1. Test equipment	11
4.2. Block diagram of test setup.....	12
4.3. Limit	14
4.4. Test Procedure	15
4.5. Test result.....	15
5. Output Power.....	24
5.1. Test equipment	24
5.2. Block diagram of test setup.....	24
5.3. Limit	24
5.4. Test Procedure	24
5.5. Test result	25
6. -6dB Bandwidth.....	30
6.1. Test equipment	30
6.2. Block diagram of test setup.....	30
6.3. Limit	30
6.4. Test Procedure	30
6.5. Test result	31
7. Band Edges Measurement.....	37
7.1. Test equipment	37
7.2. Block diagram of test setup.....	37
7.3. Limit	37

7.4. Test Procedure.....	37
7.5. Test result	38
8. Conducted Spurious Emission.....	44
8.1. Test equipment.....	44
8.2. Block diagram of test setup.....	44
8.3. Limit.....	44
8.4. Test Procedure.....	44
8.5. Test result	45
9. Conducted Output Power Spectral Density	54
9.1. Test equipment.....	54
9.2. Block diagram of test setup.....	54
9.3. Limit.....	54
9.4. Test Procedure.....	54
9.5. Test result	55
10. Antenna Requirement	61
10.1. Standard requirement	61
10.2. EUT Antenna	61
11. Test setup photograph	62
11.1. Photos of power line conducted emission test	62
11.2. Photos of radiated emission test	62
12. Photos of the EUT.....	64

TEST REPORT DECLARE

FCC ID	: 2BLC2-2868
Equipment under Test	: Wifi Digital Clock
Model /Type	: 2868w1
Listed Models	: 2868w1,2868w2,2868w3,2868b1,2868b2,2868b3 Note: Only LED and Shell are different.
Trade Mark	: JAAMIRA
Applicant	: Shenzhenshi Zhongzhimei Keji Youxiangongsi
Address	: 2D-227F,2nd Floor, Block 213, Tai Ran Science and Technology Park, Tai Ran Sixth Road, Tian An Community, Shatou Street, Futian District, Shenzhen, China
Manufacturer	: Shenzhenshi Zhongzhimei Keji Youxiangongsi
Address	: 2D-227F,2nd Floor, Block 213, Tai Ran Science and Technology Park, Tai Ran Sixth Road, Tian An Community, Shatou Street, Futian District, Shenzhen, China
Test Laboratory	: Dongguan New Testing Centre Co., Ltd
Address	: 1F & 3F, No. 1 the 1st North Industry Road Songshan Lake Science & Technology Park Dongguan, People' s Republic of China 523808

Test Standard Used:

FCC Rules and Regulations Part 15 Subpart C: 15.247, ANSI C63.10:2020.

We Declare:

The equipment described above is tested by Dongguan New Testing Centre Co., Ltd and in the configuration tested the equipment complied with the standards specified above. The test results are contained in this test report and Dongguan New Testing Centre Co., Ltd is assumed of full responsibility for the accuracy and completeness of these tests.

After test and evaluation, our opinion is that the equipment provided for test compliance with the requirement of the above FCC standards.

Report No.:	NTC-ER2409026		
Date of Test:	Sept.10,2024 to Sept.20,2024	Date of Report.:	Sept.26, 2024

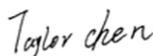
Prepared By:**Taylor Chen/Engineer****Approved By:****Dave Gao/LAB Manager**

Note: This report applies to above tested sample only. This report shall not be reproduced in parts without written approval of Dongguan New Testing Centre Co., Ltd

1. Summary of test results

Description of Test Item	Standard	Results
Antenna Requirement	Section 15.247(c)	PASS
Conduction Emissions	Section 15.207(a)	PASS
Radiated Emissions	Section 15.247(d)	PASS
Carrier Frequencies Separated	Section 15.247(a)(1)	PASS
Dwell Time	Section 15.247(a)(1) (iii)	PASS
Maximum Peak Output Power	Section 15.247(b)	PASS
Band edge	Section 15.247(d)	PASS
Conducted Spurious Emissions	Section 15.247(d)	PASS

2. General test information

Description of EUT

EUT* Name	: Wifi Digital Clock
Test model	: 2868w1
EUT function description	: Please reference user manual of this device
Power supply	: DC 5V From Type-C or DC 3.3V From Battery
Supported type:	: Bluetooth Low Energy
Modulation Technology:	: GFSK
Channel Separation:	: 5 MHz
Antenna Type	: PCB Antenna
Gain:	: Max 2.21dBi
Hardware Version:	: V1.0
Software Version:	: V1.0

Note: 1, EUT is the ab. of equipment under test.

Frequency list:

The Applicant provides communication tools software to control the EUT for staying in continuous transmitting (Duty Cycle more than 98%) and receiving mode for testing. There are 40 channels provided to the EUT and Channel 00/19/39 were selected for BLE test.

Operation Frequency List :

Channel	Frequency (MHz)
00	2402
02	2404
03	2406
⋮	⋮
19	2440
⋮	⋮
37	2476
38	2478
39	2480

Note: The line display in grey were the channel selected for testing

2.1. Detail models

Model	Rating	Note
2868w1	DC 3.3V	N/A
2868w2	DC 3.3V	
2868w3	DC 3.3V	
2868b1	DC 3.3V	
2868b2	DC 3.3V	
2868b3	DC 3.3V	

Note: Only LED and Shell are different

2.2. Test Peripheral List

No.	Equipment	Manufacturer	Model No.	Serial No.	Note
1	Notebook	Lenovo	ThinkPadE450	PF-0LRXDH	--

2.3. Block diagram EUT configuration for test

For EUT Tx mode:

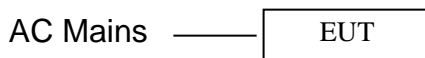

2.4. Test environment conditions

During the measurement the environmental conditions were within the listed ranges:

(1) E.U.T. test conditions:

15.31(e): For intentional radiators, measurements of the variation of the input power or the radiated signal level of the fundamental frequency component of the emission, as appropriate, shall be performed with the supply voltage varied between 85% and 115% of the nominal rated supply voltage. For battery operated equipment, the equipment tests shall be performed using a new battery.

(2) Test frequencies:

According to the 15.31(m) Measurements on intentional radiators or receivers, other than TV broadcast receivers, shall be performed and. If required reported for each band in which the device can be operated with the device operating at the number of frequencies in each band specified in the following table:

Frequency range over which device operates	Number of frequencies	Location in the range of operation
1 MHz or less	1	Middle
1 to 10 MHz	2	1 near top and 1 near bottom
More than 10 MHz	3	1 near top, 1 near middle and 1 near bottom

(3) Frequency range of radiated measurements:

According to the 15.33, the test range will be up to the tenth harmonic of the highest fundamental frequency.

(4) Pre-test the EUT in all transmitting mode at the lowest (2402 MHz), middle (2440 MHz) and highest (2480 MHz) channel with different data packet and conducted to determine the worst-case mode,

The radiation measurements are performed in X, Y, Z axis positioning. And found the X axis positioning which it is worse case, only the test worst case mode is recorded in the report.

2.5. Measurement uncertainty

Test Item	Uncertainty
Uncertainty for Conduction emission test	3.20 dB
Uncertainty for Radiation Emission test (30MHz – 1GHz)	4.60 dB (Polarize: V)
	4.60 dB (Polarize: H)
Uncertainty for Radiation Emission test (1GHz – 18GHz)	4.82 dB (Polarize: V)
	4.52 dB (Polarize: H)
Bandwidth	±1.2%
Stop Transmitting Time Test	±0.5%
Uncertainty for frequency error	5.8 x 10 ⁻⁸

Note: This uncertainty represents an expanded uncertainty expressed at approximately the 95% confidence level using a coverage factor of k=2.

3. Power Line Conducted Emission Test

3.1. Test equipment

Item	Equipment	Manufacturer	Model No.	Serial No.	Last Cal.	Cal. Interval
1	Test Receiver	R&S	ESPI	100146	2024-05-14	1 Year
2	LISN	R&S	ENV216	3650.6550.06	2024-05-14	1 Year
3	LISN	R&S	ENV4200	1107.2387.04	2024-05-14	1 Year
4	RF Cable	HUBER	SUCOFLEX100	30722/4E	2023-05-22	2 Year
5	MEASUREMENT SOFTWARE	FARAD	EZ-EMC(VER:1.1.4.2)	N/A	N/A	N/A

3.2. BLOCK DIAGRAM OF TEST SETUP

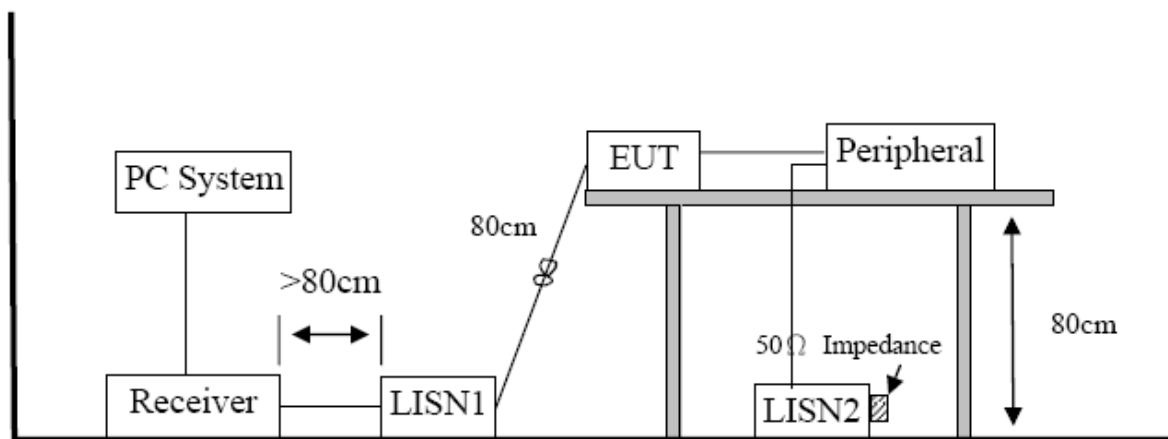

3.3. Power Line Conducted Emission Limits (Class B)

Frequency	Quasi-Peak Level dB(μ V)	Average Level dB(μ V)
150kHz ~ 500kHz	66 ~ 56*	56 ~ 46*
500kHz ~ 5MHz	56	46
5MHz ~ 30MHz	60	50

Note 1: * Decreasing linearly with logarithm of frequency.

Note 2: The lower limit shall apply at the transition frequencies.

3.4. Test Procedure

The EUT and Support equipment, if needed, were put placed on a non-metallic table, 80cm above the ground plane.

Configuration EUT to simulate typical usage as described in clause 2.3 and test equipment as described in clause 3.2 of this report.

All I/O cables were positioned to simulate typical actual usage as per ANSI C63.10.

All support equipment power received from a second LISN.

Emissions were measured on each current carrying line of the EUT using an EMI Test Receiver connected to the LISN powering the EUT.

The Receiver scanned from 150 kHz to 30MHz for emissions in each of the test modes.

During the above scans, the emissions were maximized by cable manipulation.

The test mode(s) described in clause 2.3 were scanned during the preliminary test.

After the preliminary scan, we found the test mode producing the highest emission level.

The EUT configuration and worse cable configuration of the above highest emission levels were recorded for reference of the final test.

EUT and support equipment were set up on the test bench as per the configuration with highest emission level in the preliminary test.

A scan was taken on both power lines, Neutral and Line, recording at least the six highest emissions. Emission frequency and amplitude were recorded into a computer in which correction factors were used to calculate the emission level and compare reading to the applicable limit.

The test data of the worst-case condition(s) was recorded.

The bandwidth of test receiver is set at 9 KHz.

3.5. Test Result

PASS. (See below detailed test result)

Note1: All emissions not reported below are too low against the prescribed limits.

Note2: "-----" means Peak detection; "-----" means Average detection

Note3: Measurement = Reading Level + Factor, Margin= Measurement-Limit

Note4: All modes of GFSK, Pi/4 DQPSK, and 8DPSK were test at Low, Middle, and High channel; only the worst result of GFSK Middle Channel was reported as below:

Conducted Emission Test Result

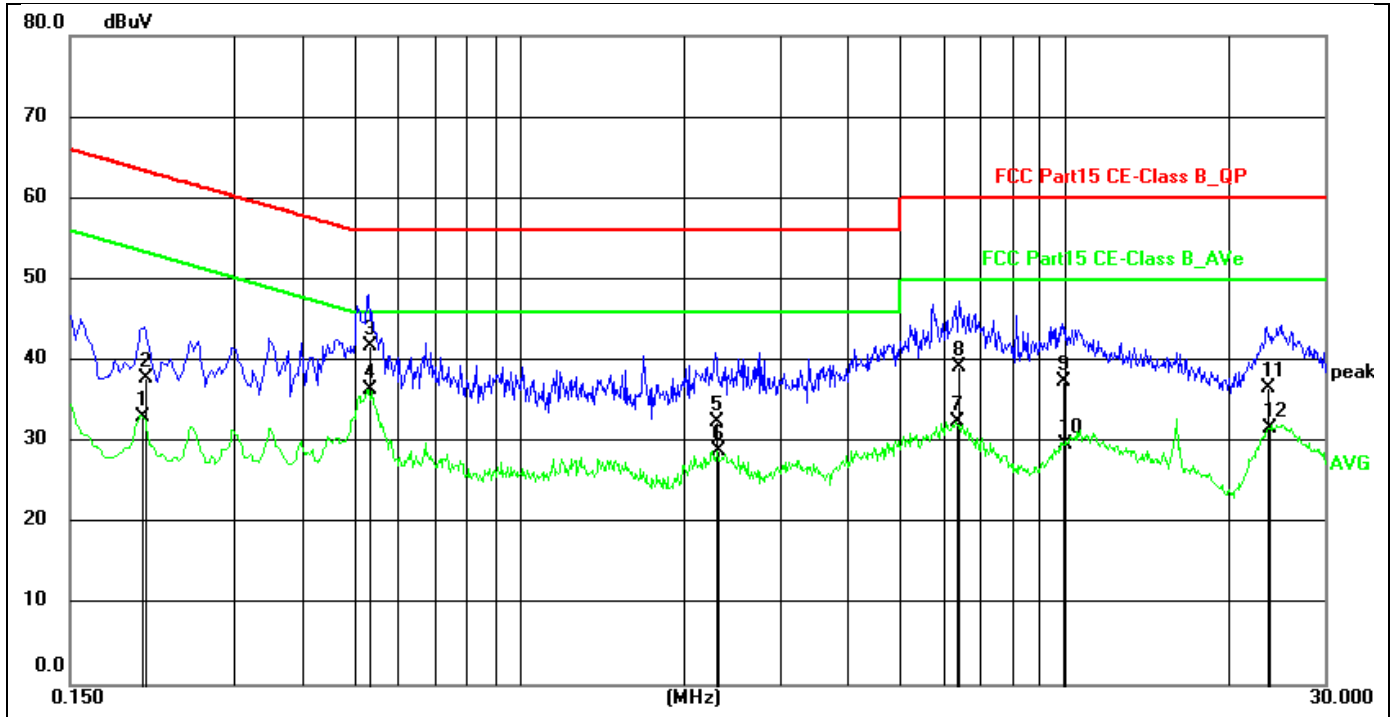

Site:	844LAB	Phase:L1	Temperature(C):24(C)
Limit:	FCC Part15 CE-Class B_QP		Humidity(%):63%
EUT:	Wifi Digital Clock	Test Time:	2024/9/23 20:01:35
M/N.:	2868W1	Power Rating:	AC120V/60Hz
Mode:	Lighting	Test Engineer:	
Note:			

No.	Frequency (MHz)	Reading Level(dBuV)	Factor (dB)	Measurement(dBuV)	Limit (dBuV)	Margin (dB)	Detector	Comment
1	0.2038	22.55	10.50	33.05	53.45	-20.40	AVG	
2	0.2060	27.31	10.50	37.81	63.37	-25.56	QP	
3	0.5299	31.19	10.54	41.73	56.00	-14.27	QP	
4 *	0.5299	25.93	10.54	36.47	46.00	-9.53	AVG	
5	2.2900	21.96	10.58	32.54	56.00	-23.46	QP	
6	2.3140	18.31	10.58	28.89	46.00	-17.11	AVG	
7	6.3338	21.93	10.61	32.54	50.00	-17.46	AVG	
8	6.4020	28.57	10.61	39.18	60.00	-20.82	QP	
9	9.9460	26.79	10.56	37.35	60.00	-22.65	QP	
10	10.0138	19.09	10.56	29.65	50.00	-20.35	AVG	
11	23.5540	24.95	11.65	36.60	60.00	-23.40	QP	
12	23.6580	20.07	11.65	31.72	50.00	-18.28	AVG	

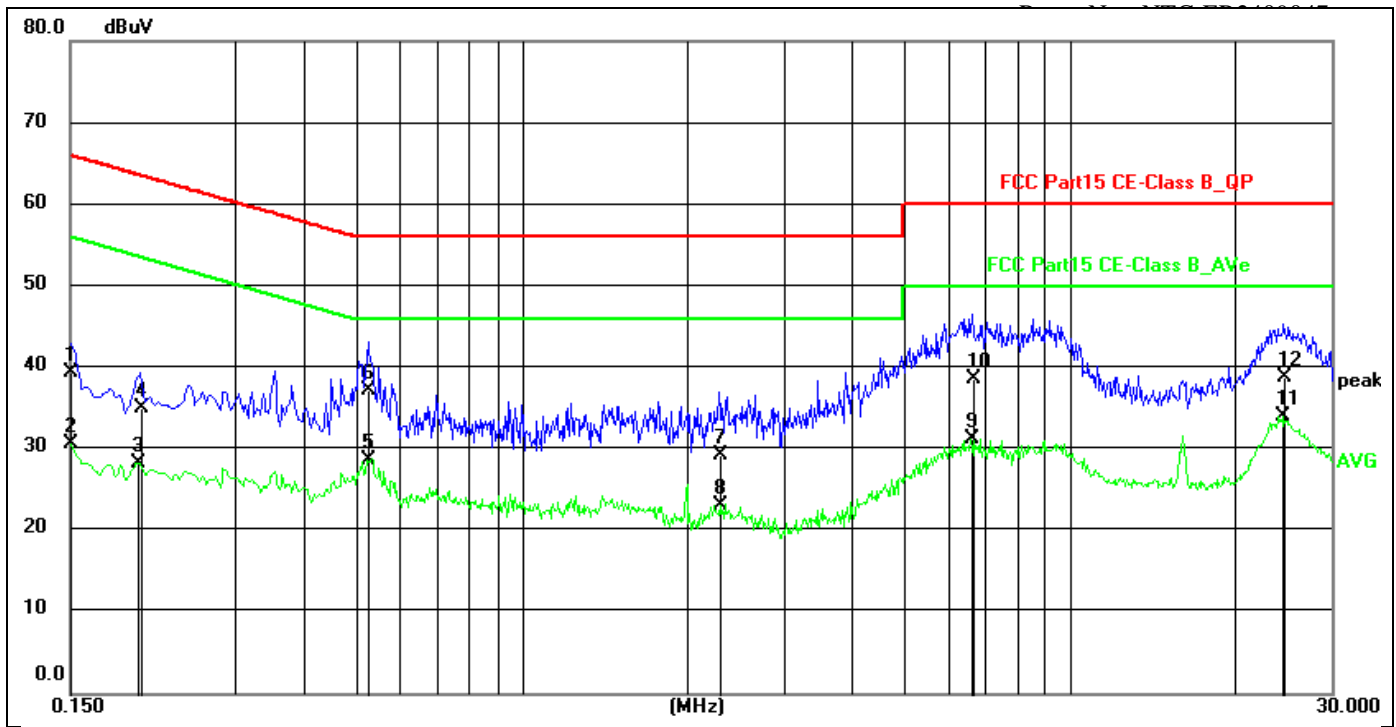

Site:	844LAB	Phase:	N	Temperature(C):	24(C)
Limit:	FCC Part15 CE-Class B_QP	Test Time:	2024/9/23 20:04:50	Humidity(%):	63%
EUT:	Wifi Digital Clock	Power Rating:	AC120V/60Hz	Test Engineer:	
M/N.:	2868W1				
Mode:	Lighting				
Note:					

No.	Frequency (MHz)	Reading Level(dBuV)	Factor (dB)	Measurement(dBuV)	Limit (dBuV)	Margin (dB)	Detector	Comment
1	0.1504	28.92	10.47	39.39	65.98	-26.59	QP	
2	0.1504	20.12	10.47	30.59	55.98	-25.39	AVG	
3	0.1996	17.74	10.47	28.21	53.63	-25.42	AVG	
4	0.2020	24.65	10.48	35.13	63.53	-28.40	QP	
5	0.5220	18.13	10.49	28.62	46.00	-17.38	AVG	
6	0.5260	26.76	10.49	37.25	56.00	-18.75	QP	
7	2.2860	18.70	10.53	29.23	56.00	-26.77	QP	
8	2.3020	12.59	10.53	23.12	46.00	-22.88	AVG	
9	6.6059	20.69	10.56	31.25	50.00	-18.75	AVG	
10	6.6460	27.96	10.57	38.53	60.00	-21.47	QP	
11 *	24.4980	22.28	11.69	33.97	50.00	-16.03	AVG	
12	24.5540	27.08	11.69	38.77	60.00	-21.23	QP	

4. Radiated emission test

4.1. Test equipment

Item	Equipment	Manufacturer	Model No.	Serial No.	Last Cal.	Cal. Interval
1	EMI Test Receiver	R&S	ESR	7250-30406 7528	2024-05-14	1 Year
2	Trilog Broadband Antenna	Schwarzbeck	VULB9168	00969	2023-05-22	2 Year
3	Pre-amplifier	R&S	8449B	3113A04553	2024-05-14	1 Year
4	Active Loop antenna	Schwarzbeck	FMZB-1519	1519-038	2024-05-14	1 Year
5	Horn antenna	Schwarzbeck	BBHA9120D	453	2023-05-19	2 Year
6	Double Ridged Horn Antenna	A.H. System	SAS-574	584	2024-05-14	1 Year
7	Pre-amplifier	R&S	SCU18	105326	2024-05-14	1 Year
8	RF Cable	GORE	OSQ01Q010 78.7	SN1545847 3	2024-05-14	1 Year
9	RF Cable	GORE	OSQ01Q010 78.7	SN1545847 4	2024-05-14	1 Year
10	RF Cable	ESCO	ETS-LINGR EN	RFC-SMS-1 00-SMS-340 -IN	2024-05-14	1 Year
11	Measurement software	Farad	EZ-EMC(VE R:1.1.4.2)	N/A	N/A	N/A

4.2. Block diagram of test setup

In 3m Anechoic Chamber Test Setup Diagram for 9KHz to 30MHz:

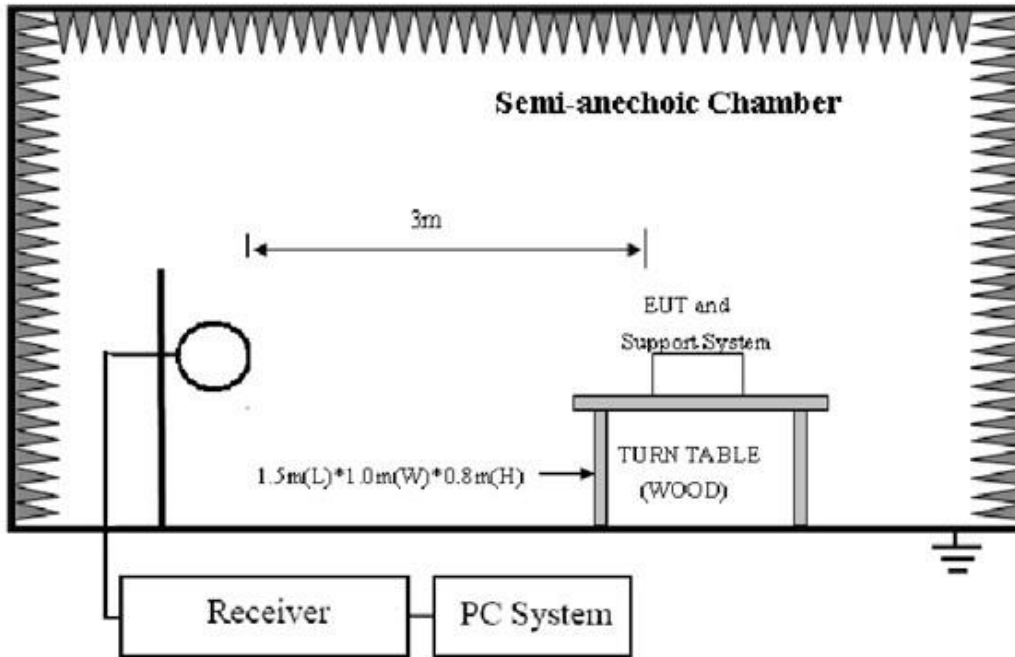

In 3m Anechoic Chamber Test Setup Diagram for 30MHz to 1GHz:

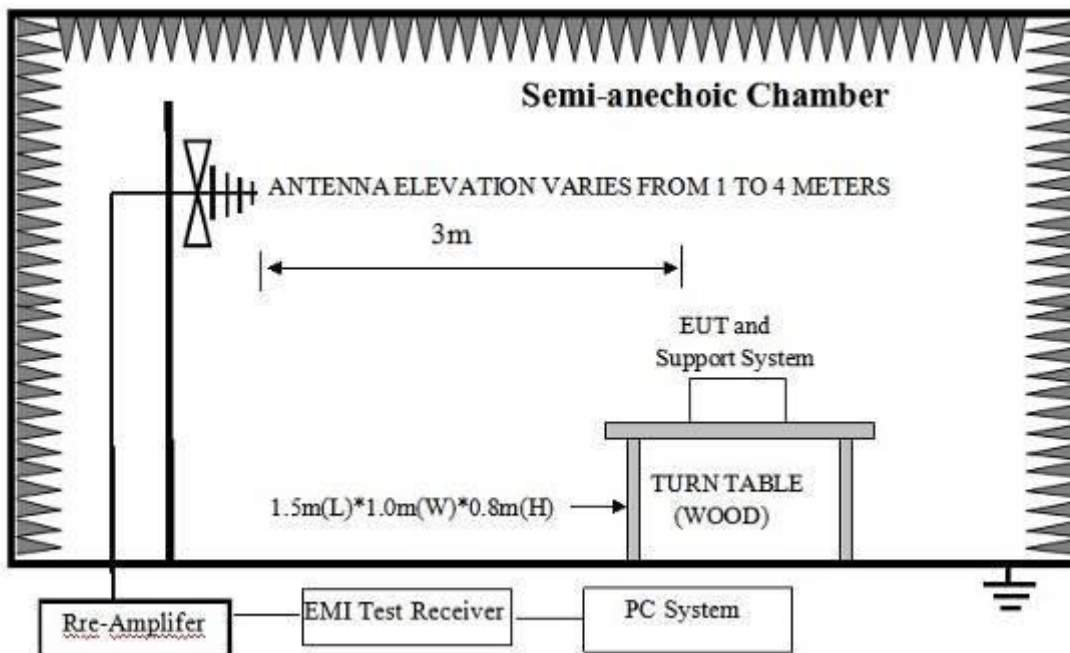

In 3m Anechoic Chamber Test Setup Diagram for frequency above 1GHz:

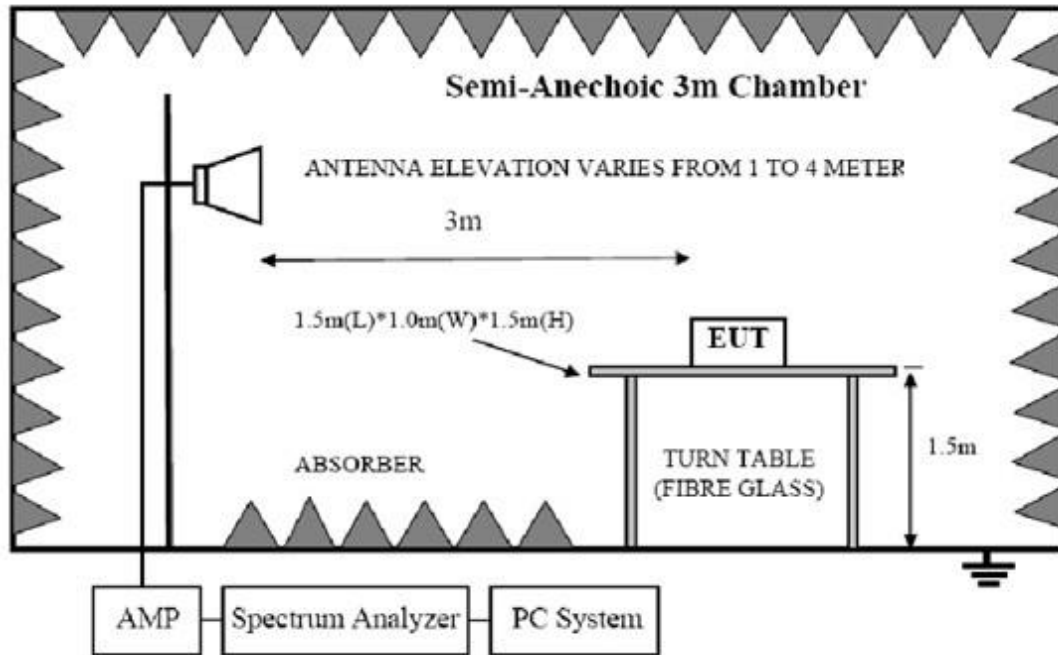

4.3. Limit

FCC 15.205 Restricted frequency band:

MHz	MHz	MHz	GHz
0.090 - 0.110	16.42 - 16.423	399.9 - 410	4.5 - 5.15
¹ 0.495 - 0.505	16.69475 - 16.69525	608 - 614	5.35 - 5.46
2.1735 - 2.1905	16.80425 - 16.80475	960 - 1240	7.25 - 7.75
4.125 - 4.128	25.5 - 25.67	1300 - 1427	8.025 - 8.5
4.17725 - 4.17775	37.5 - 38.25	1435 - 1626.5	9.0 - 9.2
4.20725 - 4.20775	73 - 74.6	1645.5 - 1646.5	9.3 - 9.5
6.215 - 6.218	74.8 - 75.2	1660 - 1710	10.6 - 12.7
6.26775 - 6.26825	108 - 121.94	1718.8 - 1722.2	13.25 - 13.4
6.31175 - 6.31225	123 - 138	2200 - 2300	14.47 - 14.5
8.291 - 8.294	149.9 - 150.05	2310 - 2390	15.35 - 16.2
8.362 - 8.366	156.52475 - 156.52525	2483.5 - 2500	17.7 - 21.4
8.37625 - 8.38675	156.7 - 156.9	2690 - 2900	22.01 - 23.12
8.41425 - 8.41475	162.0125 - 167.17	3260 - 3267	23.6 - 24.0
12.29 - 12.293	167.72 - 173.2	3332 - 3339	31.2 - 31.8
12.51975 - 12.52025	240 - 285	3345.8 - 3358	36.43 - 36.5
12.57675 - 12.57725	322 - 335.4	3600 - 4400	(²)

FCC 15.109 Limit

Frequency (MHz)	Distance (Meters)	Field Strengths Limits dB(μV)/m
30--88	3	40.0
88--216	3	43.5
216--960	3	46.0
960--1000	3	54.0
Above 1GHz	3	Peak: 74.0
	3	Average:54.0

Note: (1) The smaller limit shall apply at the cross point between two frequency bands.

(2)Distance is the distance in meters between the measuring instrument, antenna and the closest point of any part of the device or system.

(3)The emission limits shown in the above table are based on measurements employing a CISPR QP detector except for the frequency bands 9-90KHz, 110-490KHz and above 1000MHz.Radiated emissions limits in these three bands are based on measurements employing an average detector.

(4) At frequencies below 30MHz, measurement may be performed at a distance closer then that specified, and the limit at closer measurement distance can be extrapolated by below formula:
 $Limit\ 3m(dBuV/m) = Limit_{30m}(dBuV/m) + 40Log(30m/3m)$

(5)All the emissions appearing within 15.205 restricted frequency bands shall not exceed the limits shown in 15.109, all the other emissions shall be at least 20dB below the fundamental emissions, or comply with 15.109 limits.

4.4. Test Procedure

Procedure of Preliminary Test

Configuration EUT to simulate typical usage as described in clause 2.3 and test equipment as described in clause 4.2 of this report.

Mains cables, telephone lines or other connections to auxiliary equipment located outside the test are shall drape to the floor, be fitted with ferrite clamps or ferrite tubes placed on the floor at the point where the cable reaches the floor and then routed to the place where they leave the turntable. No extension cords shall be used to mains receptacle.

EUT height should be 0.8m for below 1GHz and 1.5m for above 1GHz at ground with absorbers.

The antenna was placed at 3 meter away from the EUT as stated in ANSI C63.10. The antenna connected to the Spectrum Analyzer via a cable and at times a pre-amplifier would be used.

The Analyzer / Receiver quickly scanned from 30MHz to 18GHz. The EUT test program was started. Emissions were scanned and measured rotating the EUT to 360 degrees and positioning the antenna 1 to 4 meters above the ground plane, in both the vertical and the horizontal polarization, to maximize the emission reading level.

The X, Y, Z three axial are tested and the report only the worst case.

The emissions from 9KHz to 1GHz, QP or average values were measured with EMI receiver with below RBW:

Frequency band	RBW
9KHz-150KHz	200Hz
150KHz-30MHz	9KHz
30MHz-1GHz	120KHz

For emissions above 1GHz, both Peak and Average level were measured with Spectrum Analyzer, and the RBW is set at 1MHz, VBW is set at 3MHz for Peak measure; RMS detector RBW 1MHz VBW 3MHz for Average measure.

4.5. Test result

PASS. (See below detailed test result)

All the emissions except fundamental emission from 9 KHz to 40GHz were comply with FCC PART 15.109 limits limit.

Note1: According exploratory test no any obvious emission were detected from 9KHz to 30MHz and 18GHz to 40GHz, so the final test was performed with frequency range from 30MHz to 18GHz and recorded in below.

Note2: For emissions above 1GHz. If peak results comply with AV limit, AV Result is deemed to comply with AV limit.

Note3: Level = Reading Level + Factor, Margin= Level-Limit

Radiated Emission Test Result

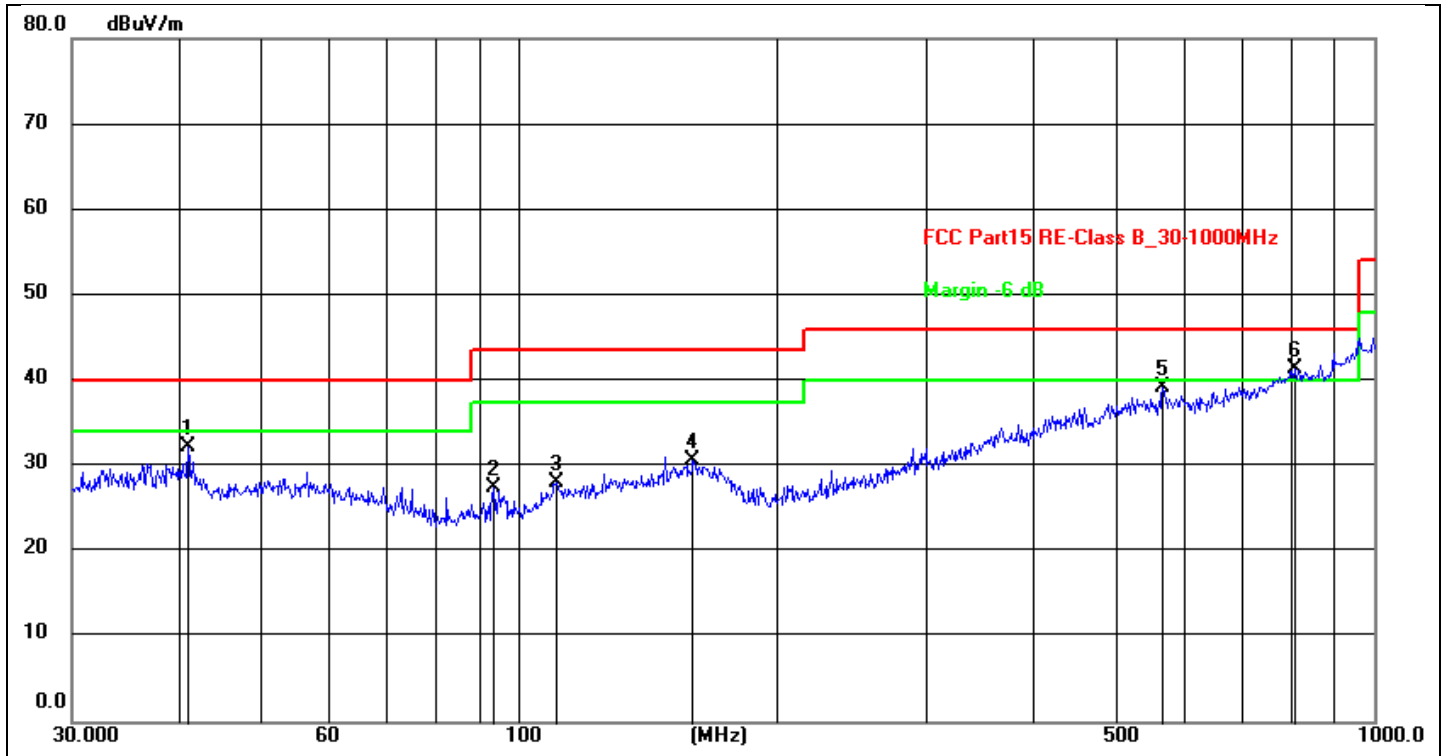

Site:	844LAB	Antenna::	Horizontal	Temperature(C):	24(C)
Limit:	FCC Part15 CE-Class B_QP	Test Time:	2024/9/24 19:23:17		
EUT:	Wifi Digital Clock	Power Rating:	AC 120V/60Hz		
M/N.:	2868W1	Test Engineer:			
Mode:	Lighting				
Note:					

No.	Frequency (MHz)	Reading (dBuV)	Factor (dB/m)	Level (dBuV/m)	Limit (dBuV/m)	Margin (dB)	Det.	Height (cm)	Azimuth (deg)	Remark
1	40.9880	18.05	14.29	32.34	40.00	-7.66	peak	200	309	
2	93.4402	17.01	10.42	27.43	43.50	-16.07	peak	200	4	
3	110.5686	14.79	13.26	28.05	43.50	-15.45	peak	200	281	
4	159.7844	15.23	15.45	30.68	43.50	-12.82	peak	100	211	
5	566.6221	17.99	21.15	39.14	46.00	-6.86	peak	200	281	
6*	810.2653	15.90	25.45	41.35	46.00	-4.65	peak	200	124	

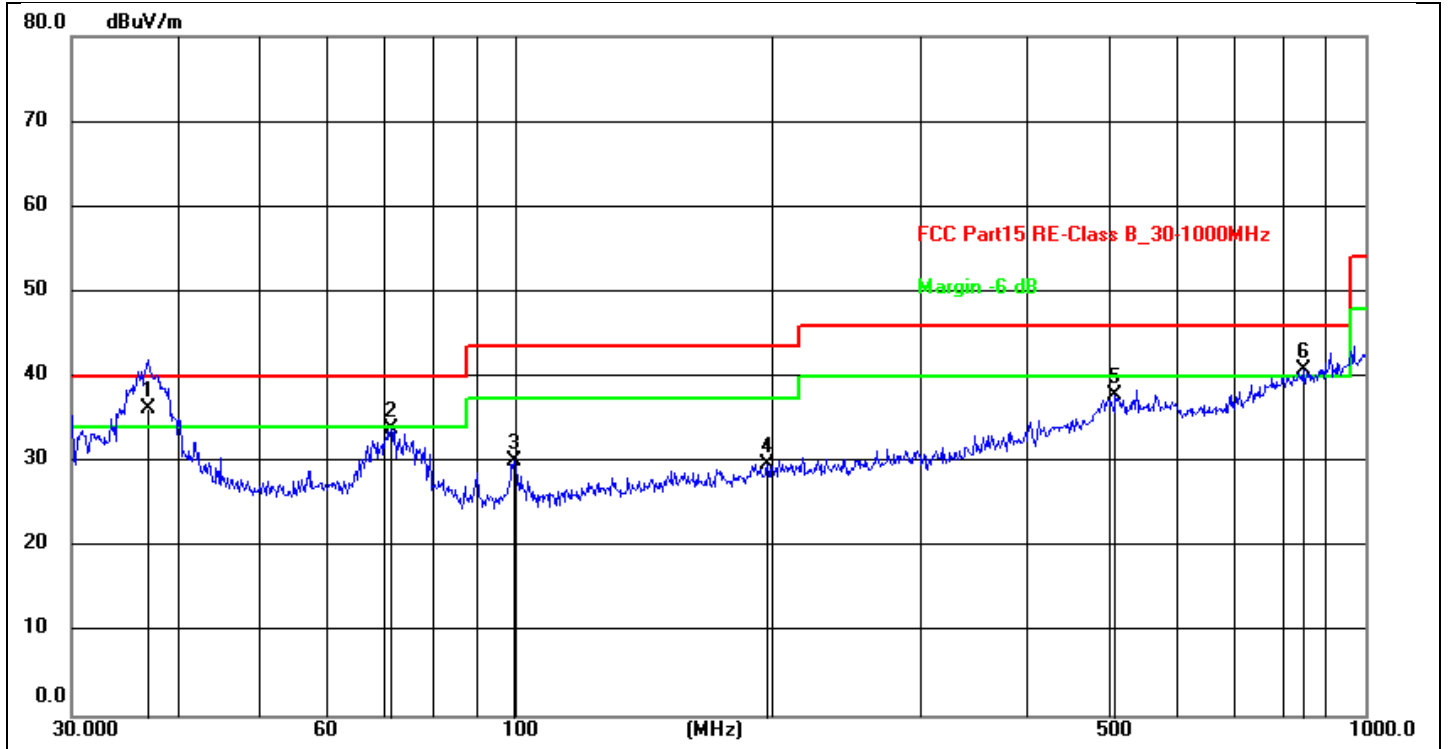

Site:	FCC Part15 RE-Class B_30-1000MHz	Antenna::Vertical	Temperature(C):24(C)
Limit:	LED	Test Time:	Humidity(%):60%
EUT:	2868	Power Rating:	2024/9/24 19:25:53
M/N.:	Lighting	Test Engineer:	AC 120V/60Hz
Mode:			
Note:			

No.	Frequency (MHz)	Reading (dBuV)	Factor (dB/m)	Level (dBuV/m)	Limit (dBuV/m)	Margin (dB)	Det.	Height (cm)	Azimuth (deg)	Remark
1 *	36.8953	20.93	15.38	36.31	40.00	-3.69	QP	200	231	
2	71.3300	21.15	12.60	33.75	40.00	-6.25	peak	200	52	
3	99.5281	17.98	12.06	30.04	43.50	-13.46	peak	100	159	
4	197.8928	15.46	14.21	29.67	43.50	-13.83	peak	100	3	
5	508.2582	17.98	19.76	37.74	46.00	-8.26	peak	200	320	
6 !	845.0878	15.89	24.83	40.72	46.00	-5.28	peak	100	3	

For 1GHz to 25GHz

 Note: GFSK, Π /4DQPSK and 8DPSK all have been tested, only worse case GFSK is reported.

GFSK (above 1GHz)

Frequency(MHz):			2402		Polarity:			HORIZONTAL	
Frequency (MHz)	Emission Level (dBuV/m)		Limit (dBuV/m)	Margin (dB)	Raw Value (dBuV)	Antenna Factor (dB/m)	Cable Factor (dB)	Pre-amplifier (dB)	Correction Factor (dB/m)
4824.00	62.15	PK	74.00	-11.85	66.42	32.33	5.12	41.72	-4.27
4824.00	45.59	AV	54.00	-8.41	48.56	32.33	5.12	41.72	-4.27
7236.00	54.08	PK	74.00	-19.92	54.60	36.6	6.49	43.61	-0.52
7236.00	43.4	AV	54.00	-10.60	43.92	36.6	6.49	43.61	-0.52

Frequency(MHz):			2402		Polarity:			VERTICAL	
Frequency (MHz)	Emission Level (dBuV/m)		Limit (dBuV/m)	Margin (dB)	Raw Value (dBuV)	Antenna Factor (dB/m)	Cable Factor (dB)	Pre-amplifier (dB)	Correction Factor (dB/m)
4824.00	60.31	PK	74.00	-13.69	64.58	32.33	5.12	41.72	-4.27
4824.00	43.34	AV	54.00	-10.66	47.68	32.33	5.12	41.72	-4.27
7236.00	52.49	PK	74.00	-21.51	53.00	36.6	6.49	43.61	-0.52
7236.00	41.72	AV	54.00	-12.28	42.23	36.6	6.49	43.61	-0.52

Frequency(MHz):			2441		Polarity:			VERTICAL	
Frequency (MHz)	Emission Level (dBuV/m)		Limit (dBuV/m)	Margin (dB)	Raw Value (dBuV)	Antenna Factor (dB/m)	Cable Factor (dB)	Pre-amplifier (dB)	Correction Factor (dB/m)
4824.00	61.21	PK	74.00	-12.79	65.09	32.6	5.34	41.82	-3.88
4824.00	44.83	AV	54.00	-9.17	48.76	32.6	5.34	41.82	-3.88
7236.00	53.33	PK	74.00	-20.67	53.44	36.8	6.81	43.72	-0.11
7236.00	42.57	AV	54.00	-11.43	42.78	36.8	6.81	43.72	-0.11

Frequency(MHz):			2441		Polarity:			VERTICAL	
Frequency (MHz)	Emission Level (dBuV/m)		Limit (dBuV/m)	Margin (dB)	Raw Value (dBuV)	Antenna Factor (dB/m)	Cable Factor (dB)	Pre-amplifier (dB)	Correction Factor (dB/m)
4824.00	59.21	PK	74.00	-14.79	63.09	32.6	5.34	41.82	-3.88
4824.00	42.64	AV	54.00	-11.36	46.52	32.6	5.34	41.82	-3.88
7236.00	51.53	PK	74.00	-22.47	51.64	36.8	6.81	43.72	-0.11
7236.00	41.23	AV	54.00	-12.77	41.34	36.8	6.81	43.72	-0.11

Frequency(MHz):			2480		Polarity:			VERTICAL	
Frequency (MHz)	Emission Level (dBuV/m)		Limit (dBuV/m)	Margin (dB)	Raw Value (dBuV)	Antenna Factor (dB/m)	Cable Factor (dB)	Pre-amplifier (dB)	Correction Factor (dB/m)
4824.00	60.61	PK	74.00	-13.39	63.69	32.73	5.66	41.47	-3.08
4824.00	43.23	AV	54.00	-10.77	47.31	32.73	5.66	41.47	-3.08
7236.00	52.37	PK	74.00	-21.63	51.62	37.04	7.25	43.84	0.45
7236.00	42.15	AV	54.00	-11.85	41.72	37.04	7.25	43.84	0.45

Frequency(MHz):			2480		Polarity:			VERTICAL	
Frequency (MHz)	Emission Level (dBuV/m)		Limit (dBuV/m)	Margin (dB)	Raw Value (dBuV)	Antenna Factor (dB/m)	Cable Factor (dB)	Pre-amplifier (dB)	Correction Factor (dB/m)
4824.00	58.68	PK	74.00	-15.32	61.76	32.73	5.66	41.47	-3.08
4824.00	42.33	AV	54.00	-11.67	45.41	32.73	5.66	41.47	-3.08
7236.00	50.51	PK	74.00	-23.49	50.31	37.04	7.25	43.84	0.45
7236.00	41.45	AV	54.00	-12.55	40	37.04	7.25	43.84	0.45

REMARKS:

1. Emission level (dBuV/m) =Raw Value (dBuV)+Correction Factor (dB/m)
2. Correction Factor (dB/m) = Antenna Factor (dB/m)+Cable Factor (dB)-Pre-amplifier Factor
3. Margin value = Limit value- Emission level.
4. -- Mean the PK detector measured value is below average limit.
5. RBW1MHz VBW3MHz Peak detector is for PK value; RBW 1MHz VBW10Hz Peak detector is for AV value.
6. Other emissions are attenuated 20dB below the limits from 9 kHz to 30MHz, so it does not recorded in report.

Results of Band Edges Test (Radiated)

Note: 802.11b/802.11g/802.11n (H20)/ 802.11n (H40) all have been tested, only worse case 802.11b is reported

Frequency(MHz):			2402		Polarity:			HORIZONTAL	
Frequency (MHz)	Emission Level (dBuV/m)		Limit (dBuV/m)	Margin (dB)	Raw Value (dBuV)	Antenna Factor (dB/m)	Cable Factor (dB)	Pre-amplifier (dB)	Correction Factor (dB/m)
2390.00	61.79	PK	74	-12.21	72.21	27.42	4.31	42.15	-10.42
2390.00	43.11	AV	54	-10.89	53.53	27.42	4.31	42.15	-10.42

Frequency(MHz):			2402		Polarity:			HORIZONTAL	
Frequency (MHz)	Emission Level (dBuV/m)		Limit (dBuV/m)	Margin (dB)	Raw Value (dBuV)	Antenna Factor (dB/m)	Cable Factor (dB)	Pre-amplifier (dB)	Correction Factor (dB/m)
2390.00	59.81	PK	74	-14.19	70.23	27.42	4.31	42.15	-10.42
2390.00	41.49	AV	54	-12.51	51.91	27.42	4.31	42.15	-10.42

Frequency(MHz):			2480		Polarity:			HORIZONTAL	
Frequency (MHz)	Emission Level (dBuV/m)		Limit (dBuV/m)	Margin (dB)	Raw Value (dBuV)	Antenna Factor (dB/m)	Cable Factor (dB)	Pre-amplifier (dB)	Correction Factor (dB/m)
2483.50	61.24	PK	74	-12.76	71.35	27.7	4.47	42.28	-10.11
2483.50	42.13	AV	54	-11.87	52.24	27.7	4.47	42.28	-10.11

Frequency(MHz):			2480		Polarity:			HORIZONTAL	
Frequency (MHz)	Emission Level (dBuV/m)		Limit (dBuV/m)	Margin (dB)	Raw Value (dBuV)	Antenna Factor (dB/m)	Cable Factor (dB)	Pre-amplifier (dB)	Correction Factor (dB/m)
2483.50	59.18	PK	74	-14.82	69.29	27.7	4.47	42.28	10.11
2483.50	40.34	AV	54	-13.66	50.45	27.7	4.47	42.28	-10.11

REMARKS:

1. Emission level (dBuV/m) = Raw Value (dBuV) + Correction Factor (dB/m)
2. Correction Factor (dB/m) = Antenna Factor (dB/m) + Cable Factor (dB) - Pre-amplifier Factor
3. Margin value = Limit value - Emission level.
- 4.-- Mean the PK detector measured value is below average limit.
5. RBW1MHz VBW3MHz Peak detector is for PK value; RBW 1MHz VBW10Hz Peak detector is for AV value.
6. For fundamental frequency, RBW 3MHz VBW 3MHz Peak detector is for PK Value; RMS detector is for AV value.
7. Other emissions are attenuated 20dB below the limits from 9kHz to 30MHz, so it does not recorded in report.

5. Output Power

5.1. Test equipment

Item	Equipment	Manufacturer	Model No.	Serial No.	Last Cal.	Cal. Interval
1	MXA Signal Analyzer	KEYSIGHT	N9020A	MY54510476	2024/5/14	1 Year

5.2. BLOCK DIAGRAM OF TEST SETUP

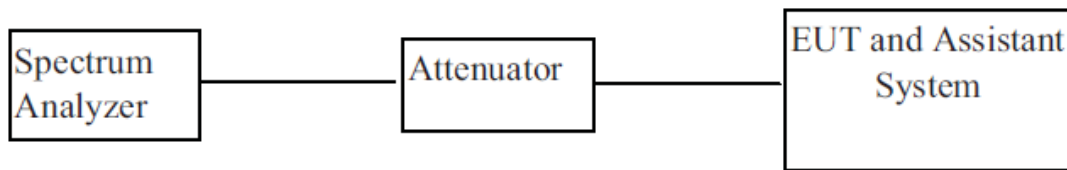

5.3. Limit

For systems using digital modulation in the 902-928 MHz, 2400-2483.5 MHz, and 5725-5850 MHz bands: 1 Watt (30dBm).

5.4. Test Procedure

For output power test:

1. Connect EUT RF output port to power sensor through an RF attenuator.
2. Connect the power sensor to the PC.
3. Set the EUT Work on the top, the middle and the bottom operation frequency individually.
4. Record the maximum power from the software.

Note : The EUT was tested according to KDB 558074v03r04 for compliance to FCC 47CFR 15.247 requirements.

5.5. Test result

Condition	Mode	Frequency (MHz)	Antenna	Conducted Power (dBm)	Duty Factor (dB)	Total Power (dBm)	Limit (dBm)	Verdict
NVNT	BLE	2402	Ant 1	5.472	0	5.472	30	Pass
NVNT	BLE	2440	Ant 1	4.044	0	4.044	30	Pass
NVNT	BLE	2480	Ant 1	2.663	0	2.663	30	Pass

Power NVNT BLE 2402MHz Ant1

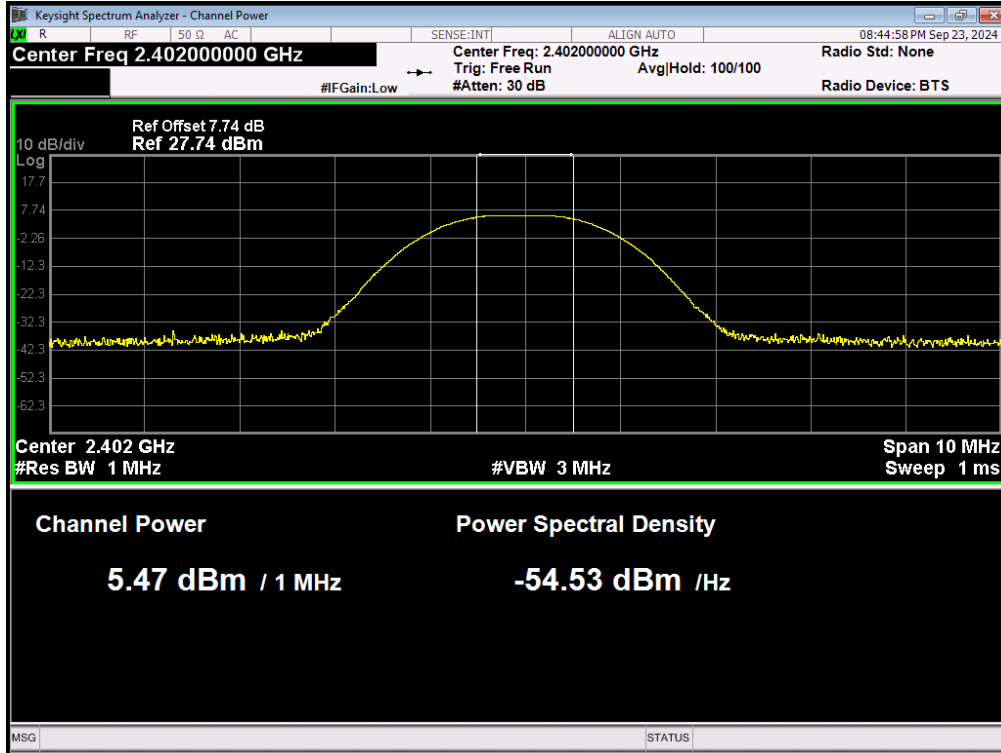

Power NVNT BLE 2440MHz Ant1

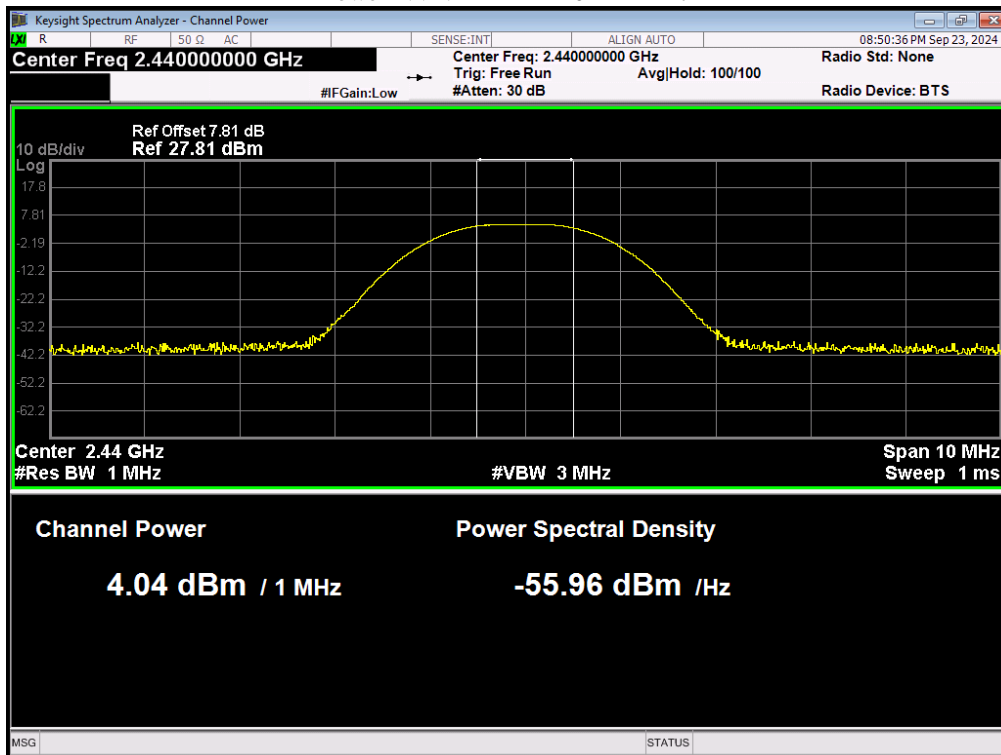

Power NVNT BLE 2480MHz Ant1

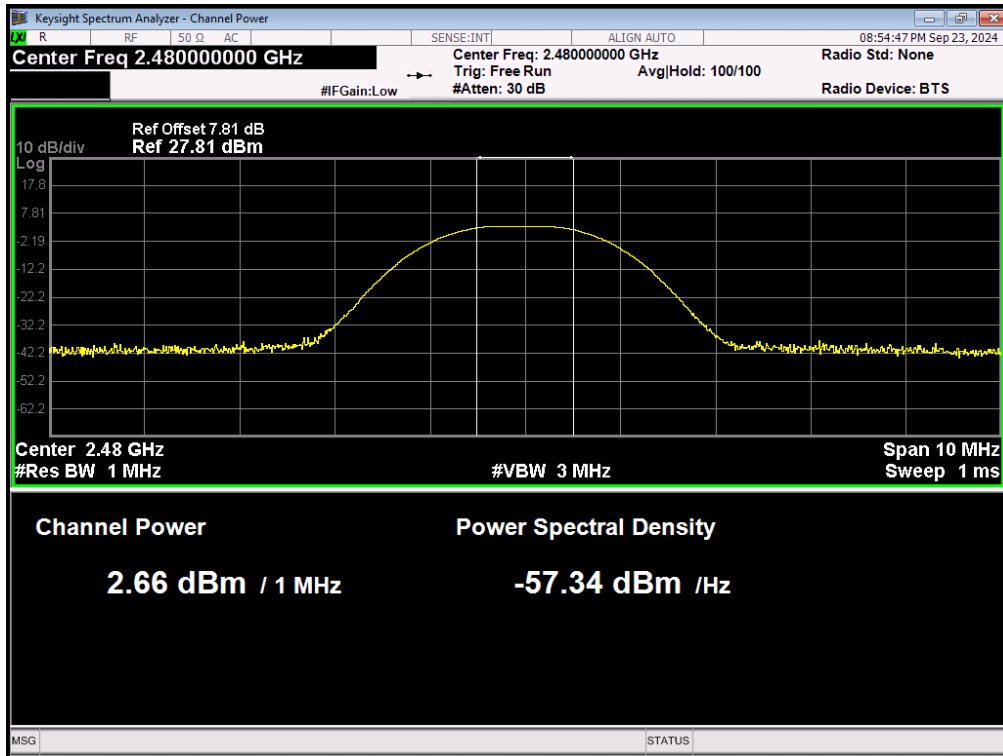

6. -6dB Bandwidth

6.1. Test equipment

Item	Equipment	Manufacturer	Model No.	Serial No.	Last Cal.	Cal. Interval
1	MXA Signal Analyzer	KEYSIGHT	N9020A	MY54510476	2024/05/14	1 Year

6.2. BLOCK DIAGRAM OF TEST SETUP

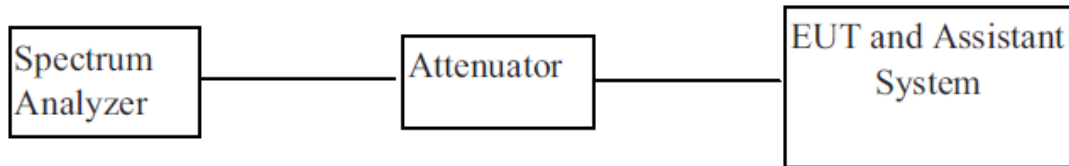

6.3. Limit

Systems using digital modulation techniques may operate in the 902 - 928 MHz, 2400 - 2483.5 MHz, and 5725 - 5850 MHz bands. The minimum 6 dB bandwidth shall be at least 500 kHz.

6.4. Test Procedure

1. Connect EUT RF output port to the Spectrum Analyzer through an RF attenuator
2. Set the EUT Work on the top, the middle and the bottom operation frequency individually.
3. Set SPA Centre Frequency = Operation Frequency, RBW= 100 KHz, VBW \geq 3 \times RBW.
4. Set SPA Trace 1 Max hold, then View.

Note: The EUT was tested according to KDB 558074 for compliance to FCC 47CFR 15.247 requirements.

6.5. Test result

Condition	Mode	Frequency (MHz)	Antenna	99% OBW (MHz)	-6 dB Bandwidth (MHz)	Limit -6 dB Bandwidth (MHz)	Verdict
NVNT	BLE	2402	Ant 1	1.0485	0.6938	0.5	Pass
NVNT	BLE	2440	Ant 1	1.0503	0.686	0.5	Pass
NVNT	BLE	2480	Ant 1	1.0519	0.7022	0.5	Pass

OBW NVNT BLE 2402MHz Ant1

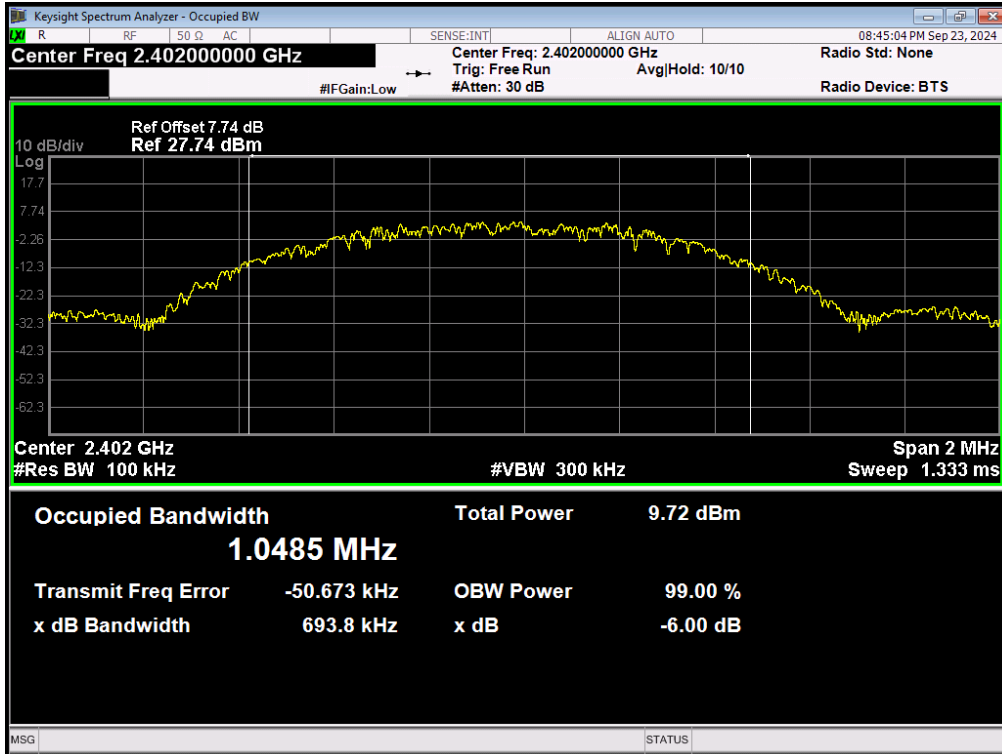

OBW NVNT BLE 2440MHz Ant1

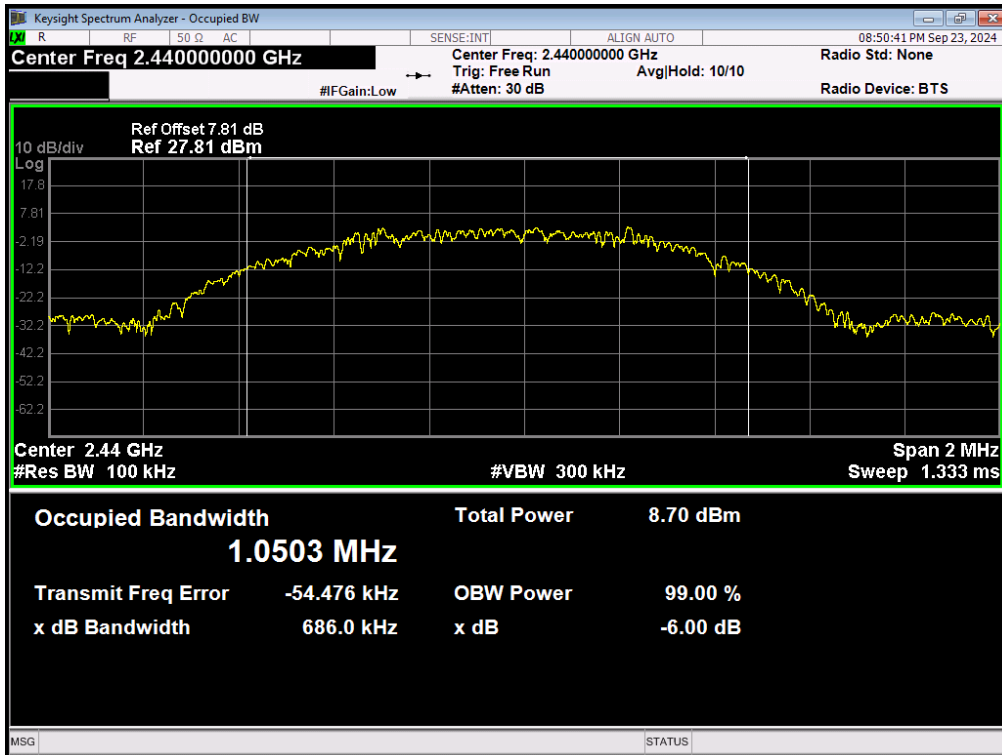

OBW NVNT BLE 2480MHz Ant1

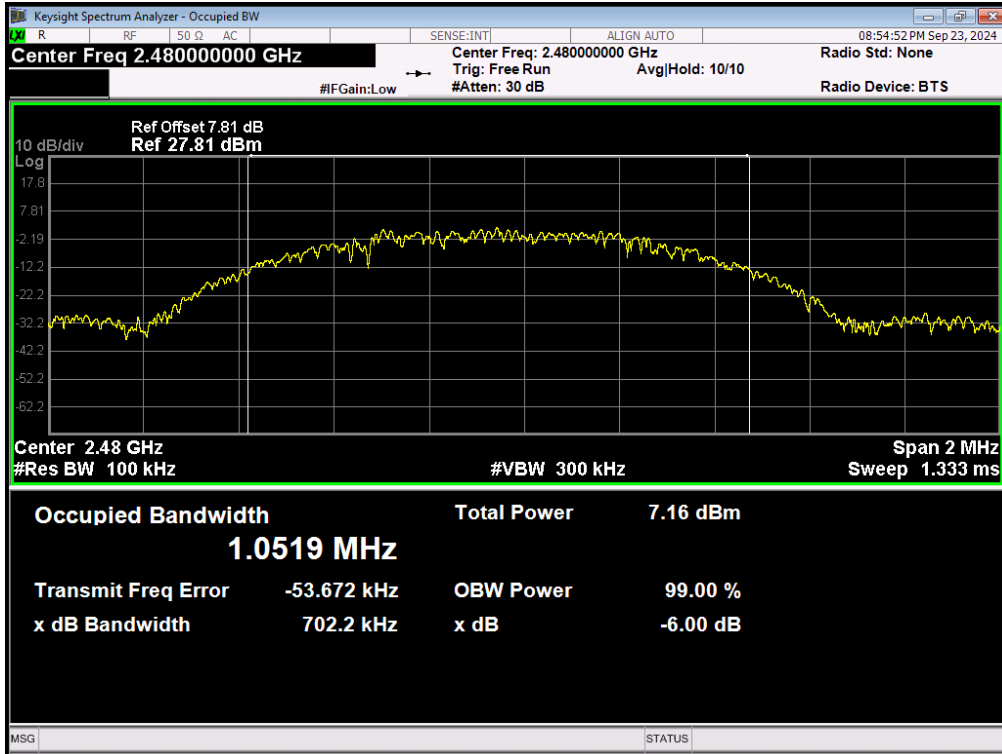

7. Band Edges Measurement

7.1. Test equipment

Item	Equipment	Manufacturer	Model No.	Serial No.	Last Cal.	Cal. Interval
1	MXA Signal Analyzer	KEYSIGHT	N9020A	MY54510476	2024/05/14	1 Year

7.2. BLOCK DIAGRAM OF TEST SETUP

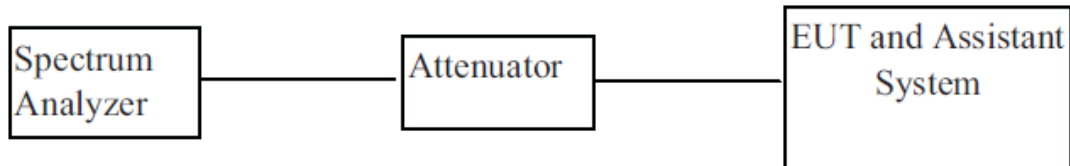

7.3. Limit

Below -30dB of the highest emission level of operating band (In 100 kHz Resolution Bandwidth)

7.4. Test Procedure

The transmitter output was connected to the spectrum analyzer via a low lose cable.

Set RBW of spectrum analyzer to 100 KHz and VBW of spectrum analyzer to 300 KHz with convenient frequency span including 100 KHz bandwidth from band edge.

Peak conducted output power measured within any 100 kHz outside the authorized frequency band shall be attenuated by at least 30dB relative to the maximum measured in-band peak PSD level.

The band edges was measured and recorded.

7.5. Test result

Condition	Mode	Frequency (MHz)	Antenna	Max Value (dBc)	Limit (dBc)	Verdict
NVNT	BLE	2402	Ant 1	-54.196	-30	Pass
NVNT	BLE	2480	Ant 1	-48.722	-30	Pass

Band Edge NVNT BLE 2402MHz Ant1 Ref

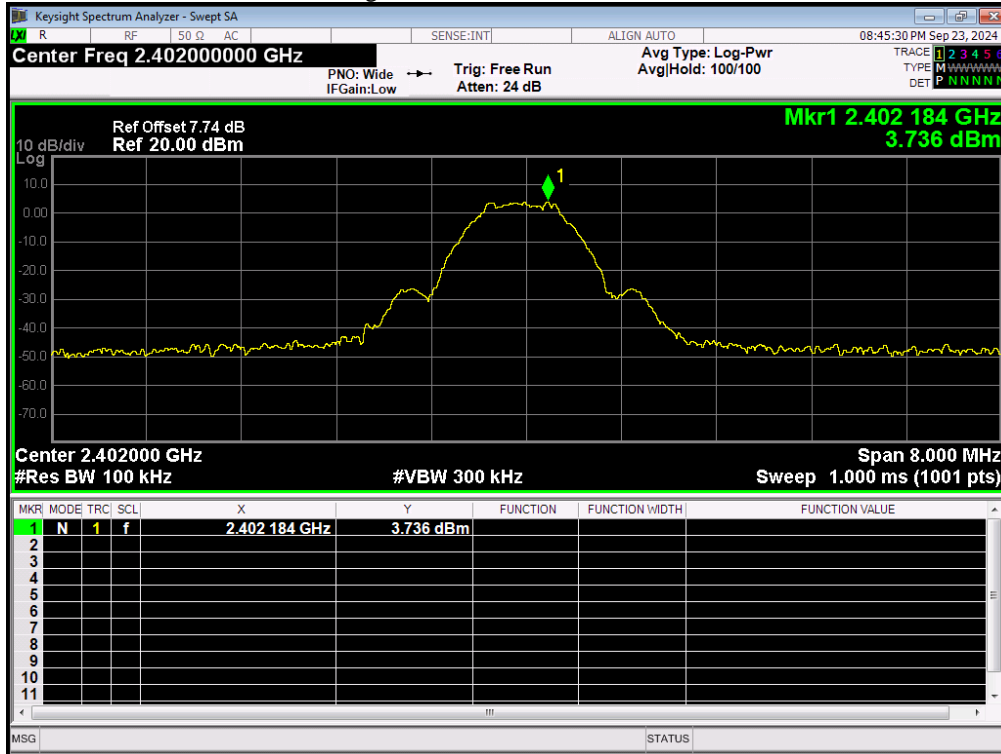

Band Edge NVNT BLE 2402MHz Ant1 Emission

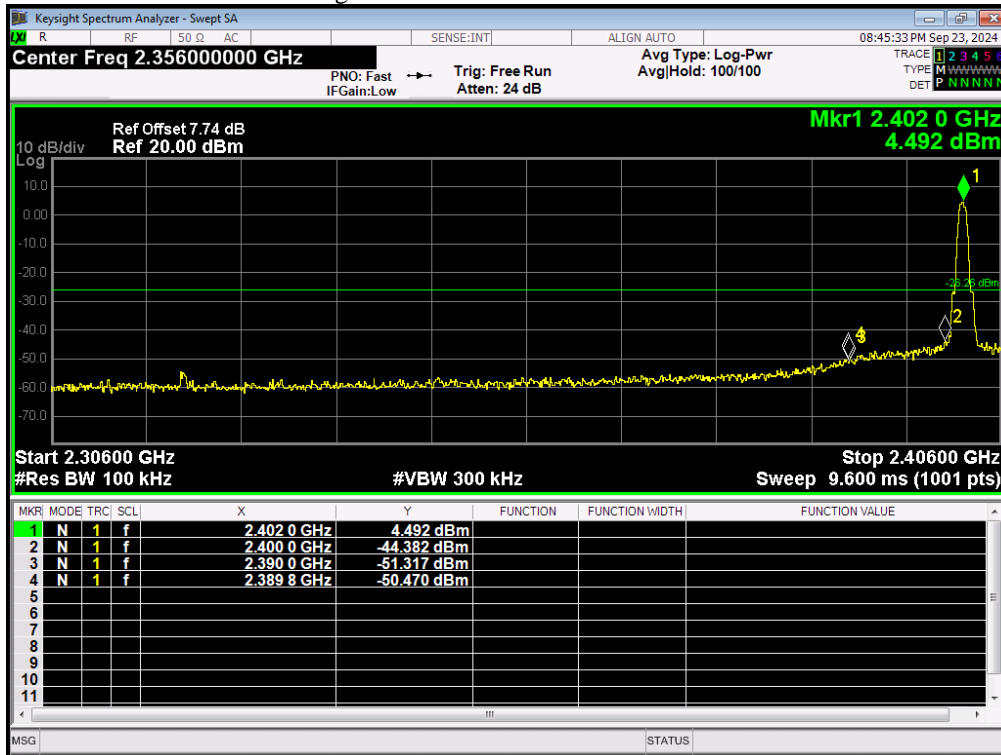

Band Edge NVNT BLE 2480MHz Ant1 Ref

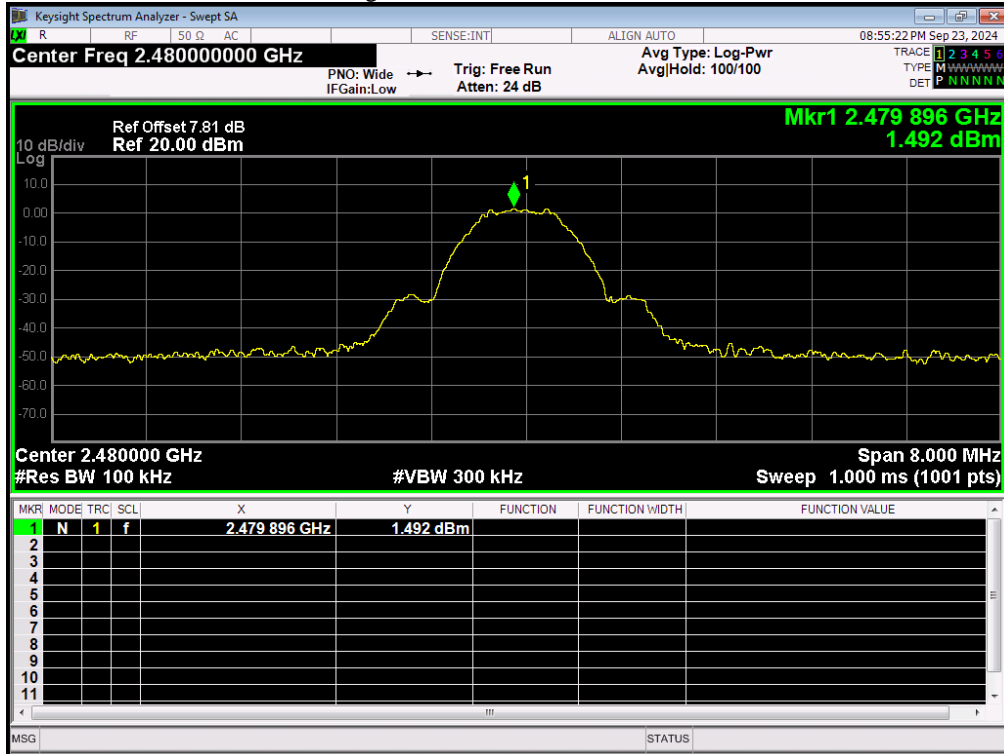

Band Edge NVNT BLE 2480MHz Ant1 Emission

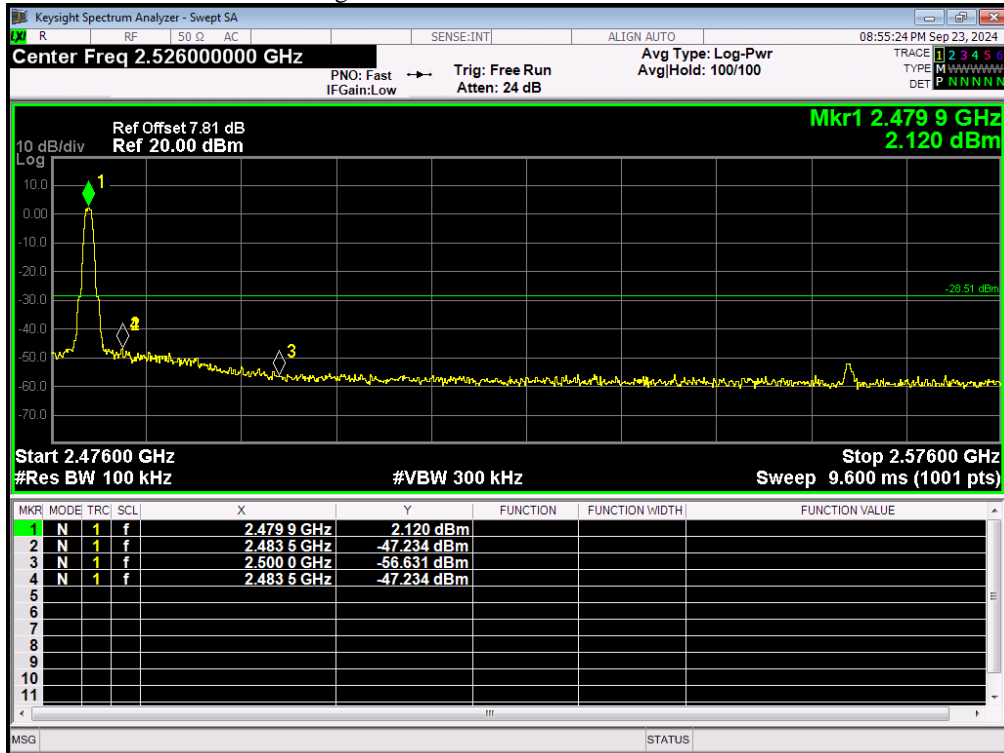

8. Conducted Spurious Emission

8.1. Test equipment

Item	Equipment	Manufacturer	Model No.	Serial No.	Last Cal.	Cal. Interval
1	MXA Signal Analyzer	KEYSIGHT	N9020A	MY54510476	2024/05/14	1 Year

8.2. BLOCK DIAGRAM OF TEST SETUP

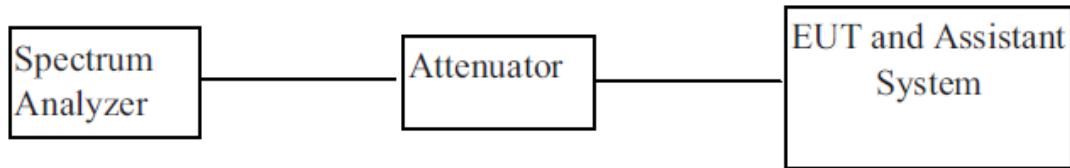

8.3. Limit

In any 100 KHz Bandwidth Outside the frequency band in which the spread spectrum intentional radiator is operating, the radio frequency power that is produce by the intentional radiator shall be at least 20 dB below that in 100KHz bandwidth within the band that contains the highest level of the desired power.

In addition, radiation emissions which fall in the restricted bands, as defined in §15.205(a), must also comply with the radiated emission limits specified in§15.209(a)

8.4. Test Procedure

1. Connect EUT RF output port to the Spectrum Analyzer through an RF attenuator
- 2, Set the EUT Work on the top, the middle and the bottom operation frequency individually.
3. Set SPA Trace 1 Max hold, then View.

Note: The EUT was tested according to KDB 558074 for compliance to FCC 47CFR 15.247 requirements. Owing to satisfy the requirements of the number of measurement points, we set the RBW=1MHz, VBW > RBW, scan up through 10th harmonic, and consider the tested results as the worst case, if the tested results conform to the requirement, we can deem that the real tested results(set the RBW=100KHz, VBW > RBW) are conform to the requirement.

8.5. Test result

Condition	Mode	Frequency (MHz)	Antenna	Max Value (dBc)	Limit (dBc)	Verdict
NVNT	BLE	2402	Ant 1	-44.052	-20	Pass
NVNT	BLE	2440	Ant 1	-43.444	-20	Pass
NVNT	BLE	2480	Ant 1	-42.423	-20	Pass

Tx. Spurious NVNT BLE 2402MHz Ant1 Ref

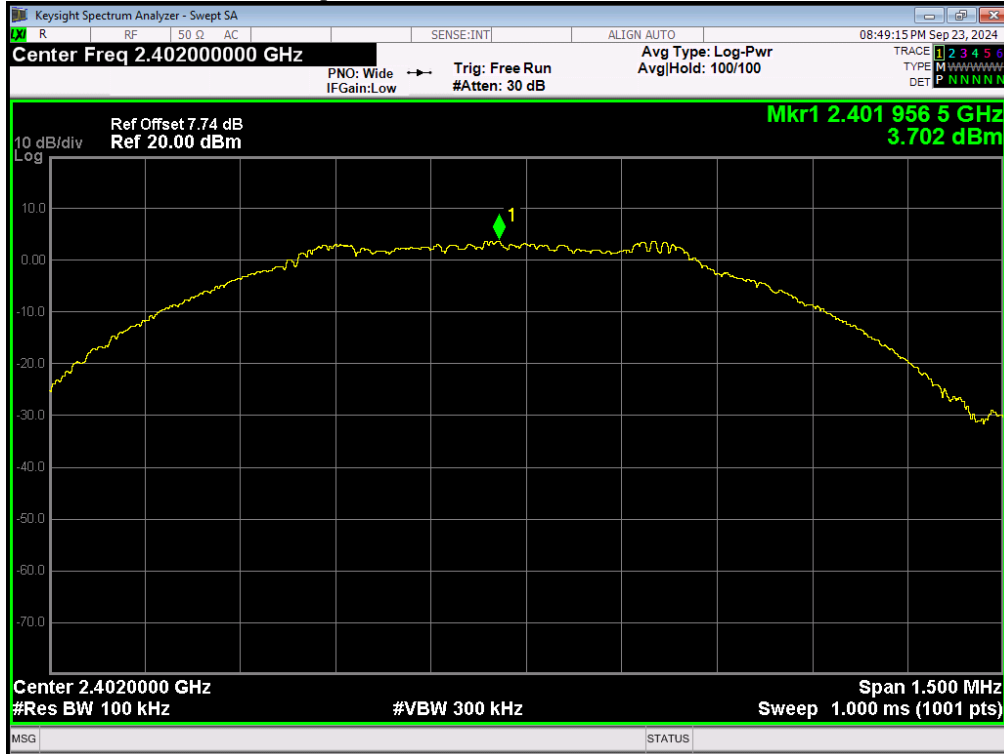

Tx. Spurious NVNT BLE 2402MHz Ant1 Emission

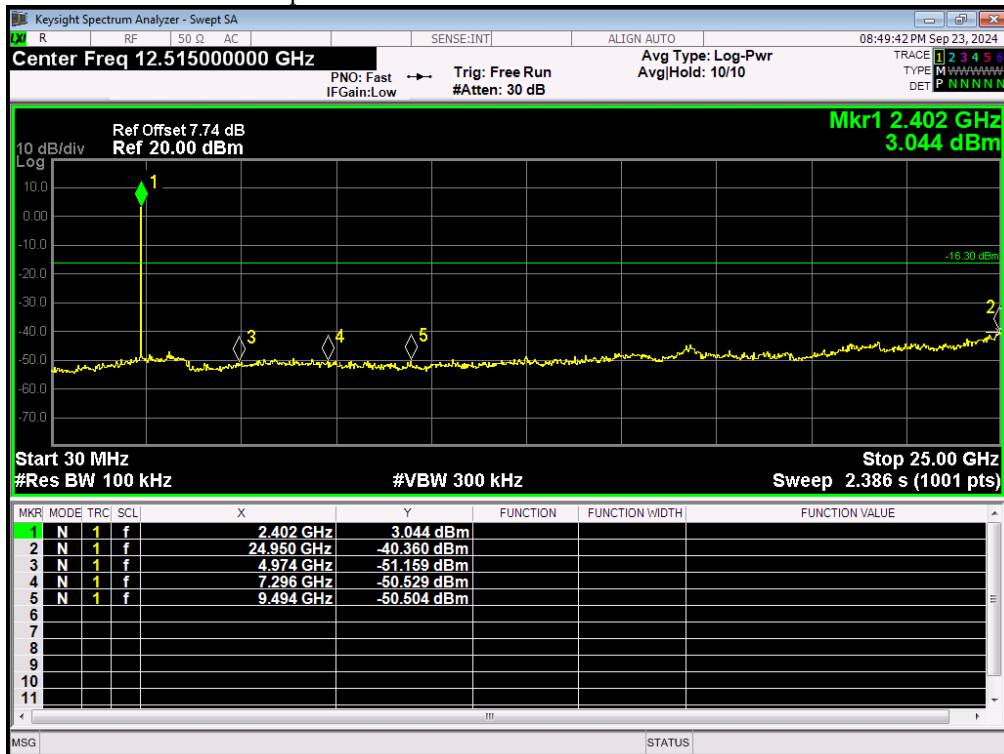

Tx. Spurious NVNT BLE 2440MHz Ant1 Ref

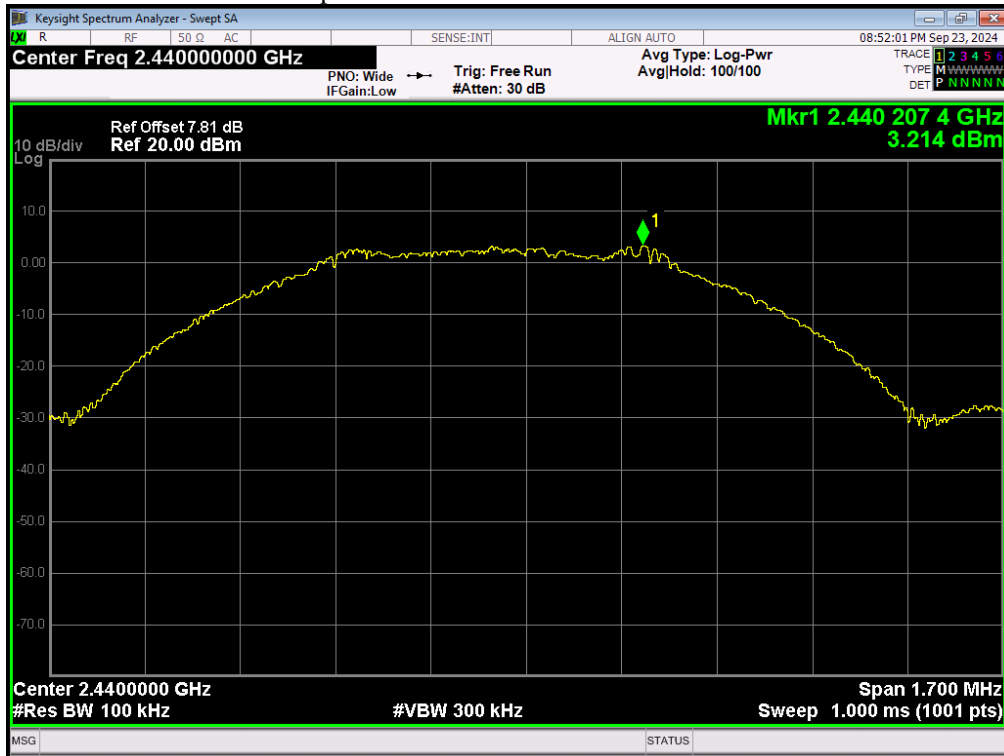

Tx. Spurious NVNT BLE 2440MHz Ant1 Emission

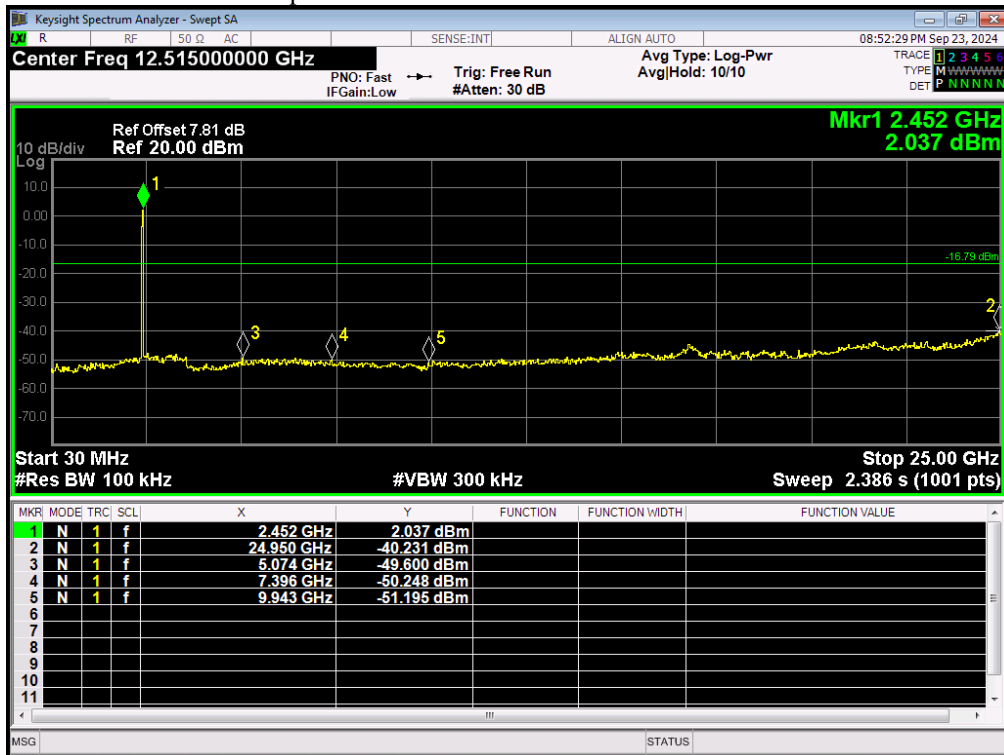

Tx. Spurious NVNT BLE 2480MHz Ant1 Ref

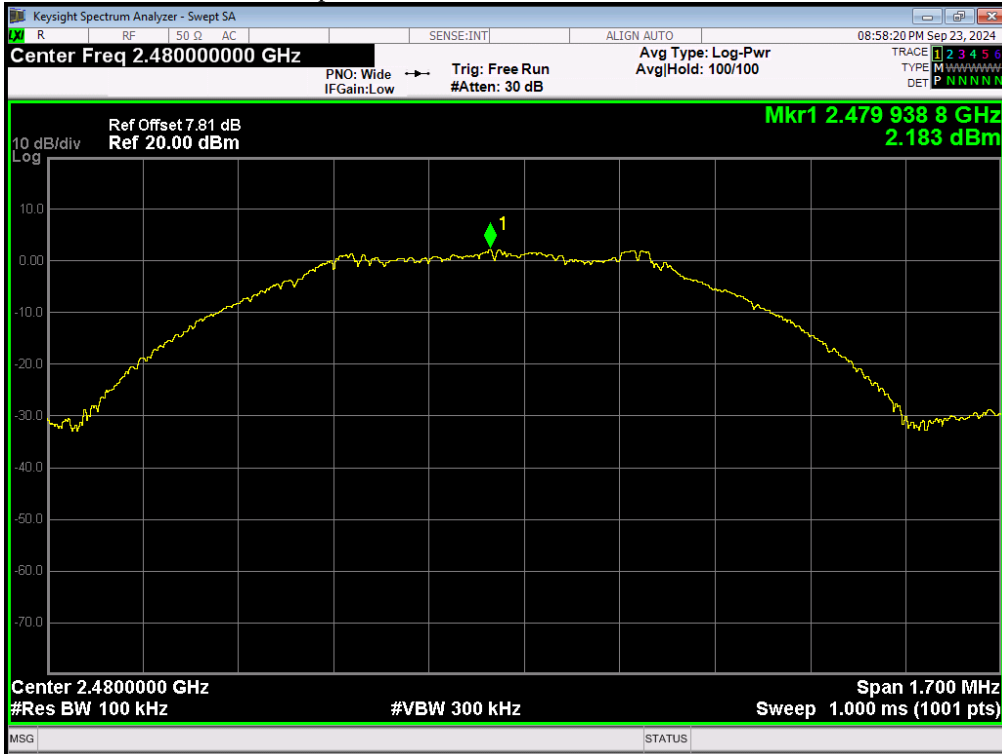

Tx. Spurious NVNT BLE 2480MHz Ant1 Emission

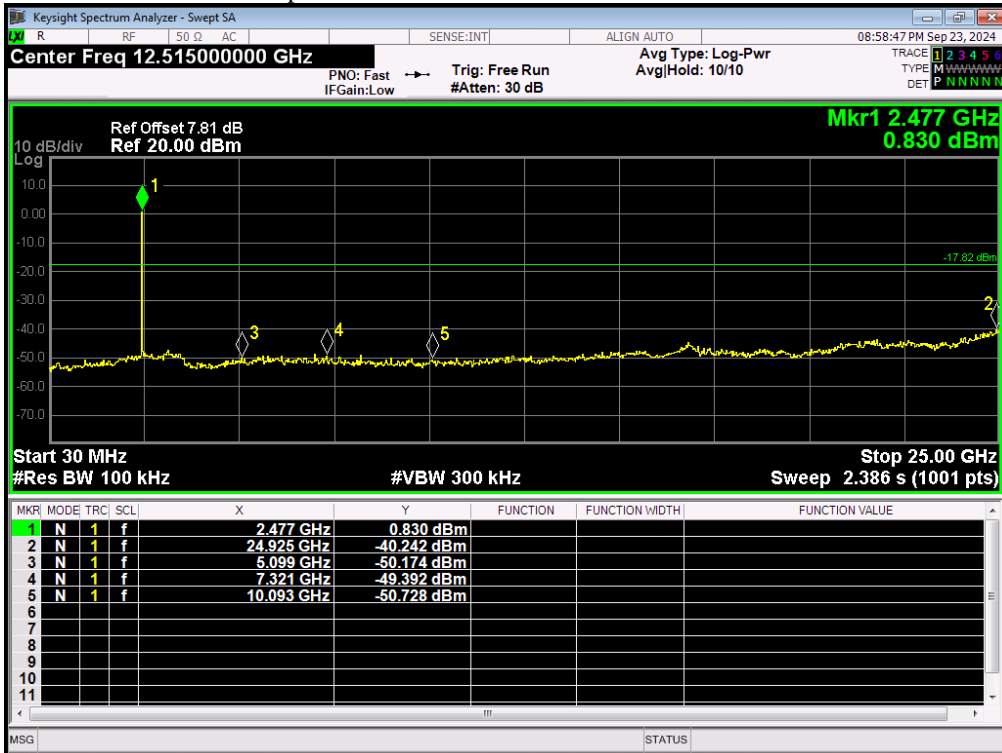

9. Conducted Output Power Spectral Density

9.1. Test equipment

Item	Equipment	Manufacturer	Model No.	Serial No.	Last Cal.	Cal. Interval
1	MXA Signal Analyzer	KEYSIGHT	N9020A	MY54510476	2024/05/14	1 Year

9.2. Block diagram of test setup

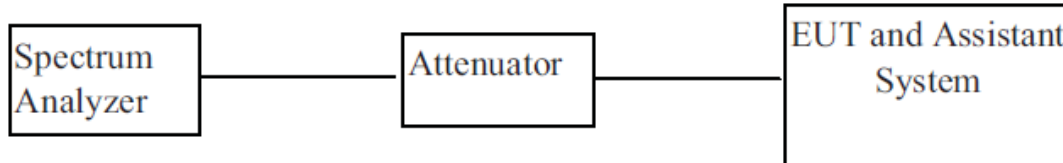

9.3. Limit

For digitally modulated systems, the power spectral density conducted from the intentional radiator to the antenna shall not be greater than 8 dBm in any 3 kHz band during any time interval of continuous transmission.

9.4. Test Procedure

- (1). Connect EUT RF output port to the Spectrum Analyzer through an RF attenuator
- (2). Set the EUT Work on the top, the middle and the bottom operation frequency individually.
- (3). Set SPA Trace 1 Max hold, then View.

9.5. Test result

Condition	Mode	Frequency (MHz)	Antenna	Max PSD (dBm/3kHz)	Limit (dBm/3kHz)	Verdict
NVNT	BLE	2402	Ant 1	-10.022	8	Pass
NVNT	BLE	2440	Ant 1	-10.429	8	Pass
NVNT	BLE	2480	Ant 1	-11.561	8	Pass

PSD NVNT BLE 2402MHz Ant1

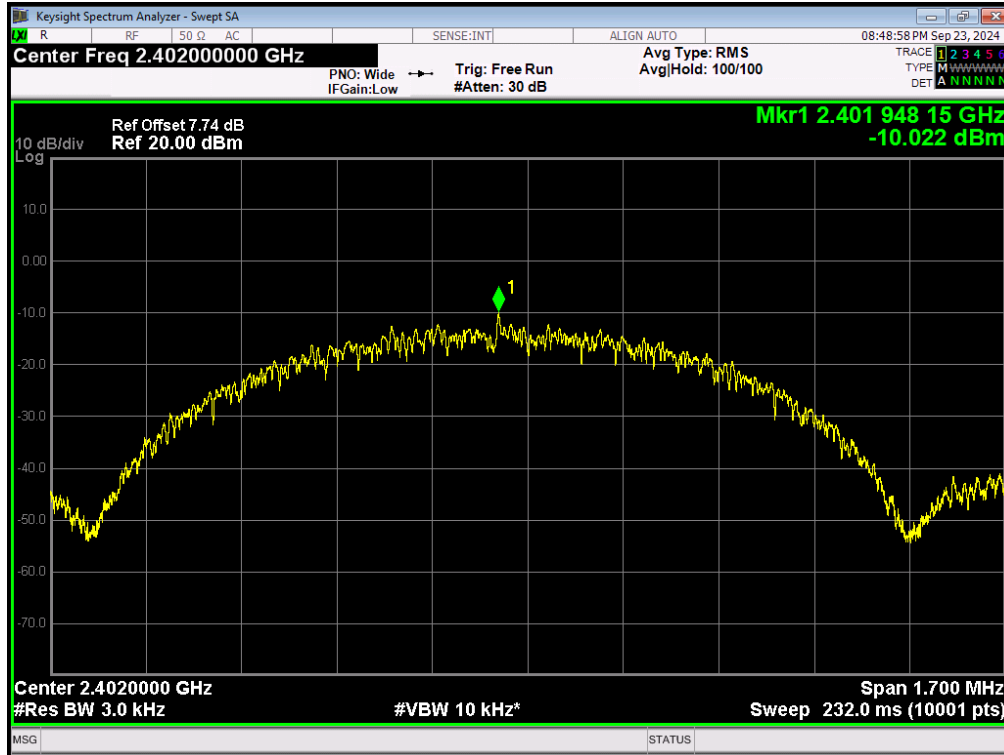

PSD NVNT BLE 2440MHz Ant1

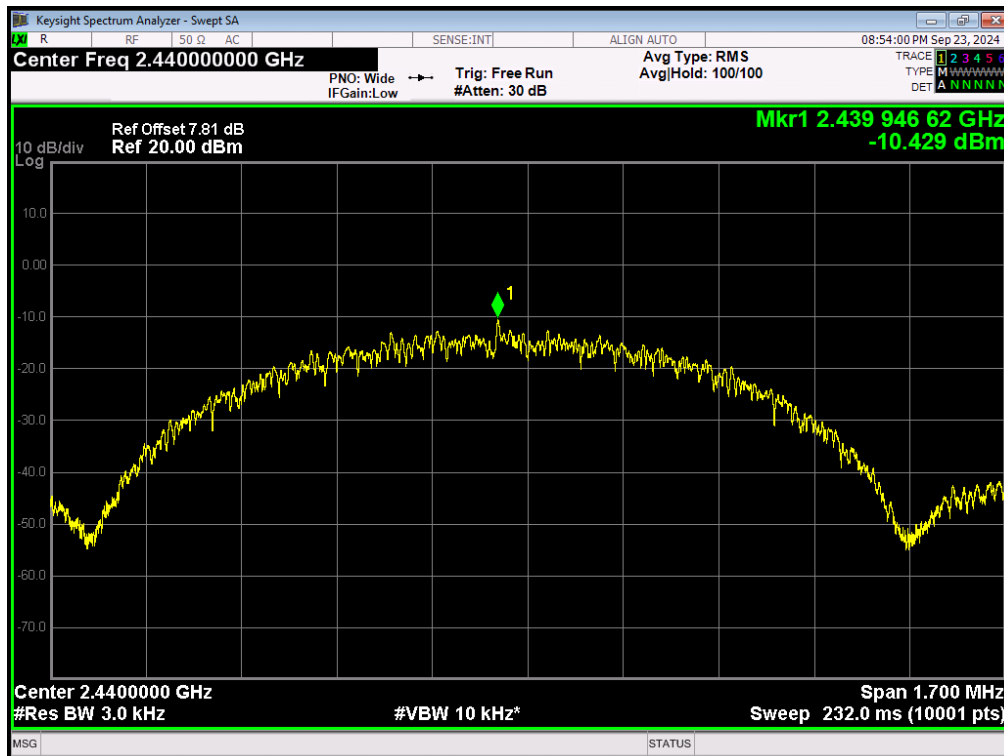

PSD NVNT BLE 2480MHz Ant1

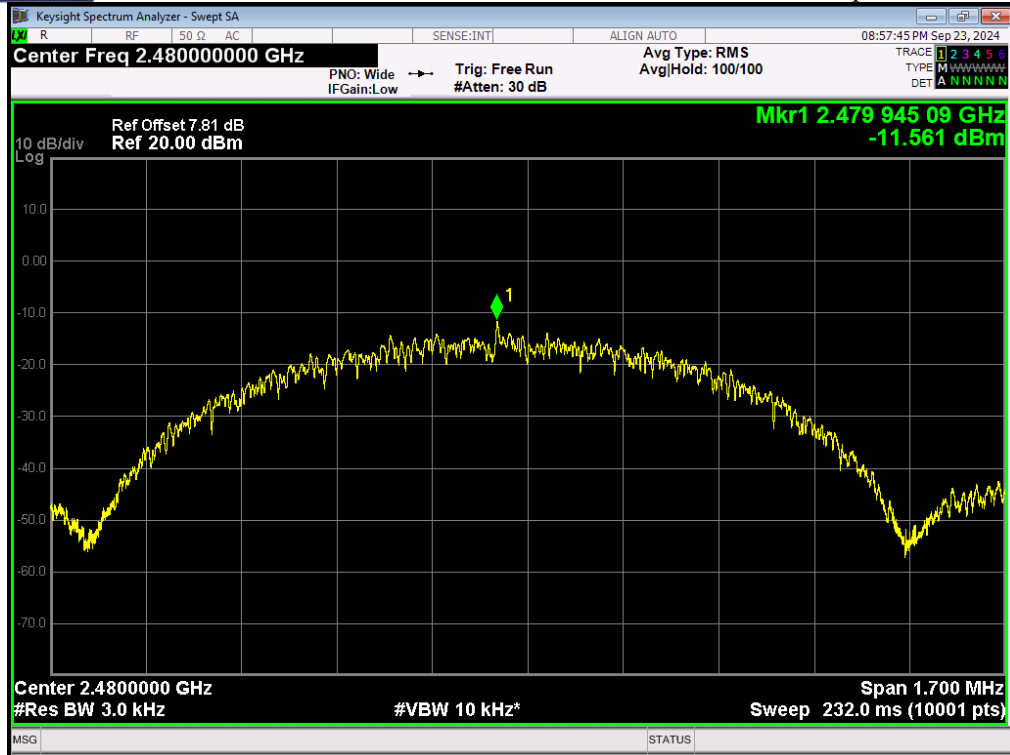

10. Antenna Requirement

10.1. Standard requirement

15.203 requirement: For intentional device, according to 15.203: an intentional radiator shall be designed to ensure that no antenna other than that furnished by the responsible party shall be used with the device.

15.247(c) (1)(i) requirement: (i) Systems operating in the 2400-2483.5 MHz band that is used exclusively for fixed. Point-to-point operations may employ transmitting antennas with directional gain greater than 6dBi provided the maximum conducted output power of the intentional radiator is reduced by 1 dB for every 3 dB that the directional gain of the antenna exceeds 6dBi.

10.2. EUT Antenna

The antenna is Integral Antenna and no consideration of replacement. Antenna gain is Maximum 2.21dBi from 2.4GHz to 2.5GHz.

11. Test setup photograph

11.1. Photos of power line conducted emission test



11.2. Photos of radiated emission test

30MHz – 1GHz



Above 1GHz



12. Photos of the EUT



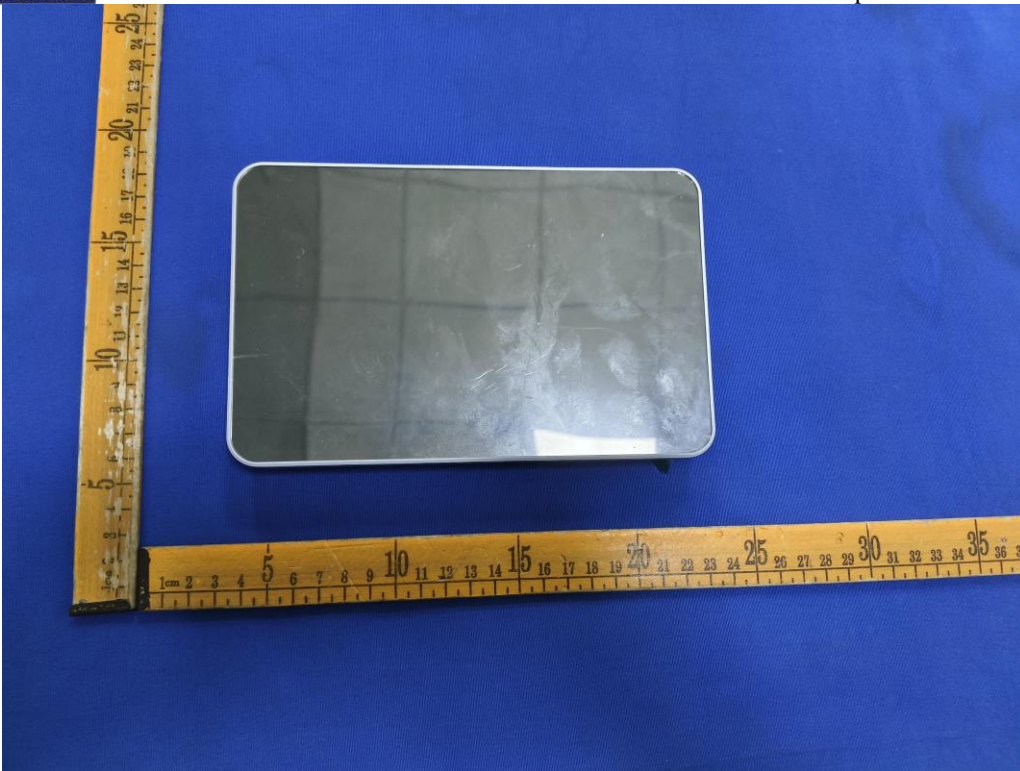

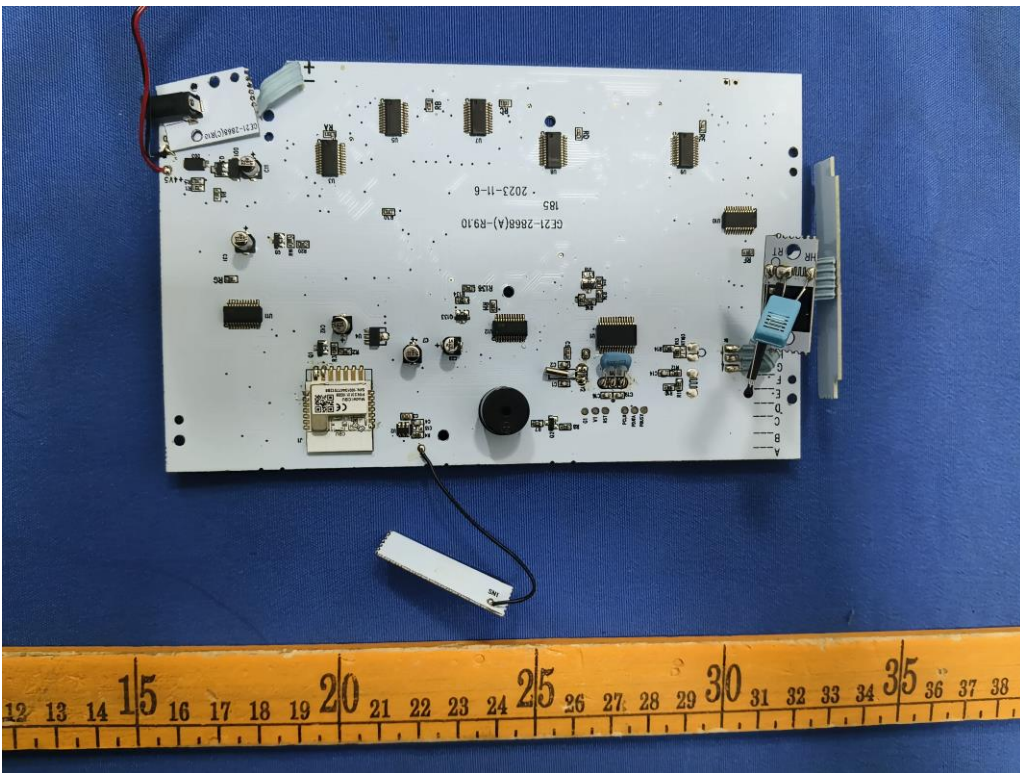
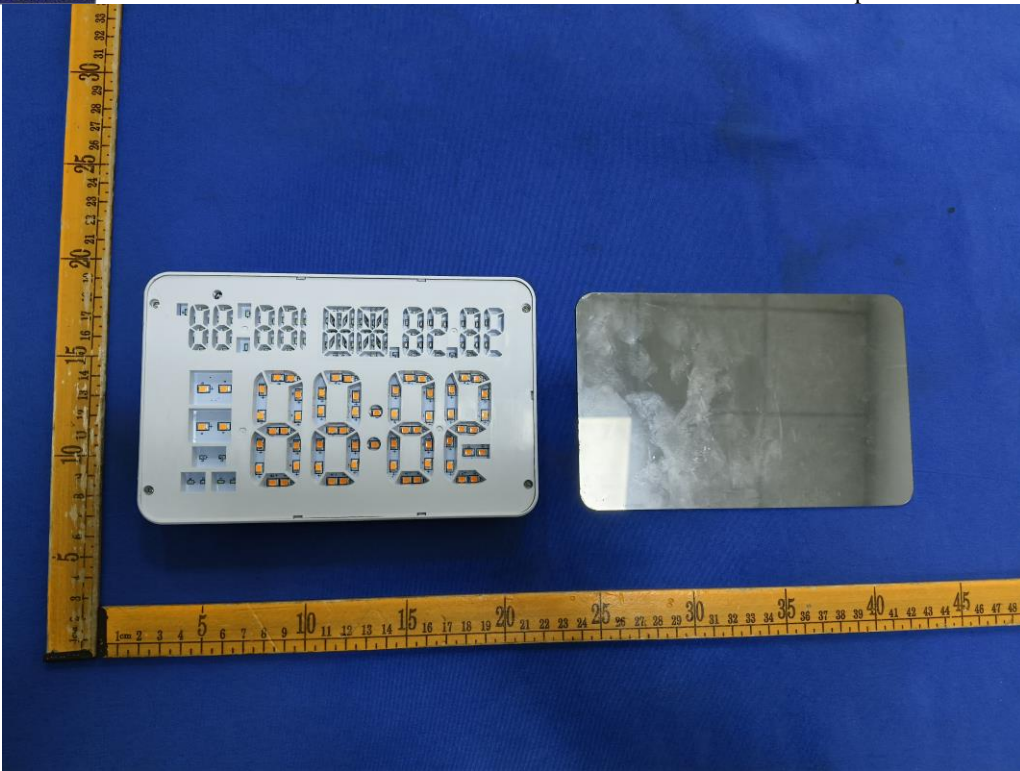

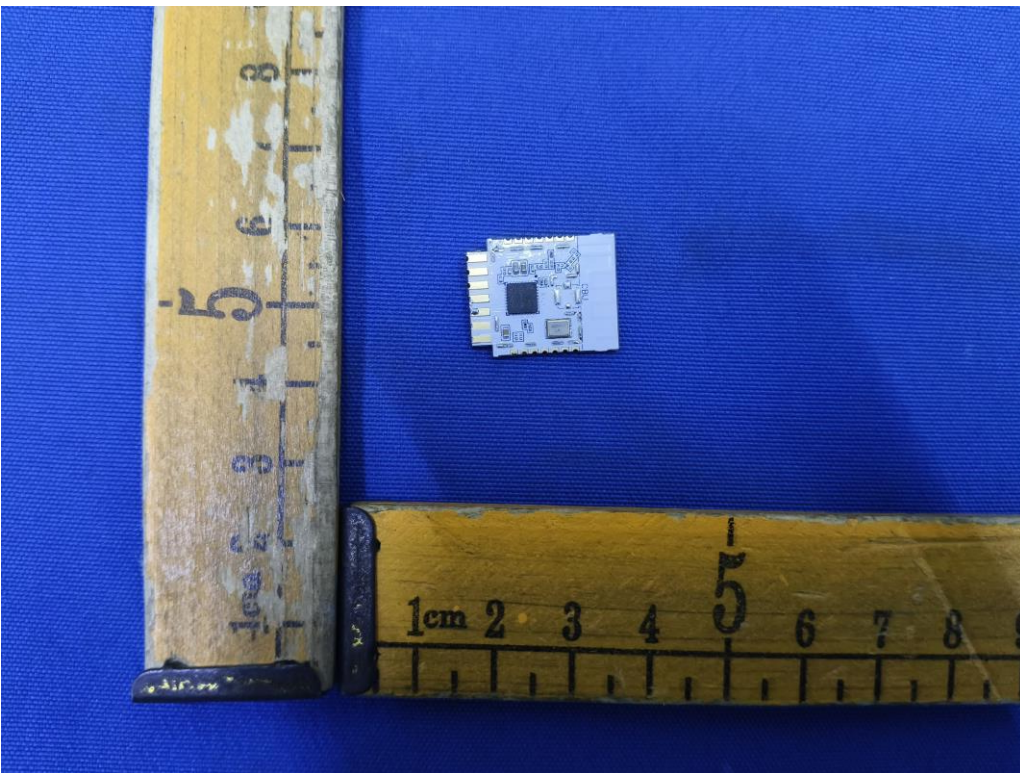
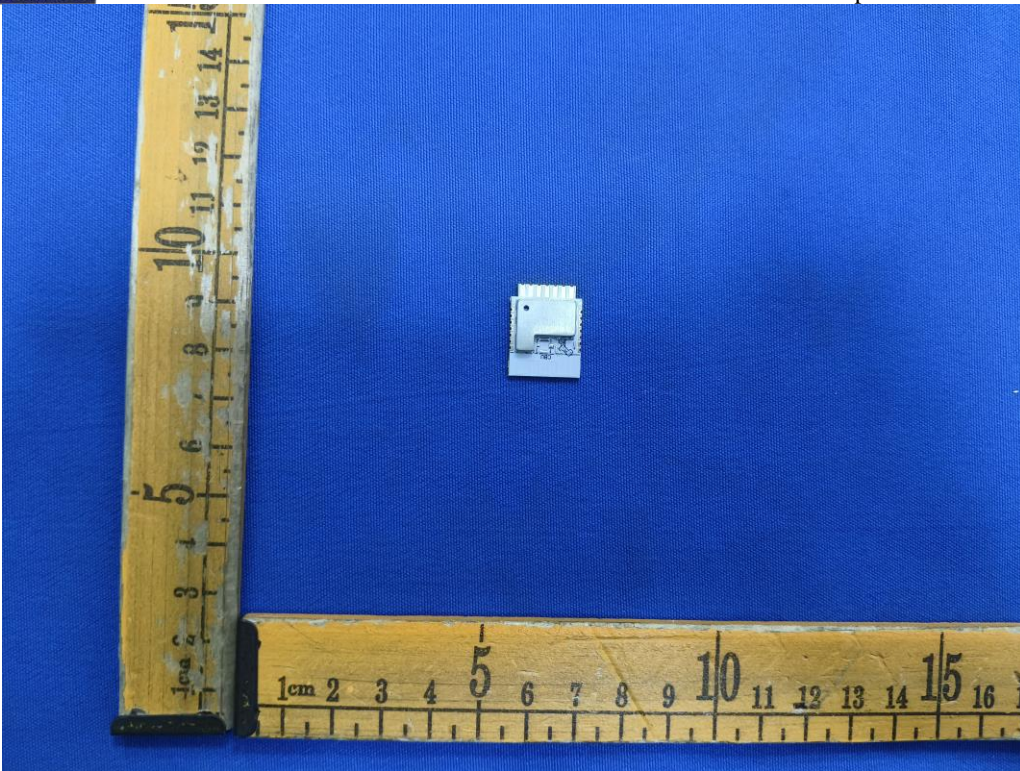

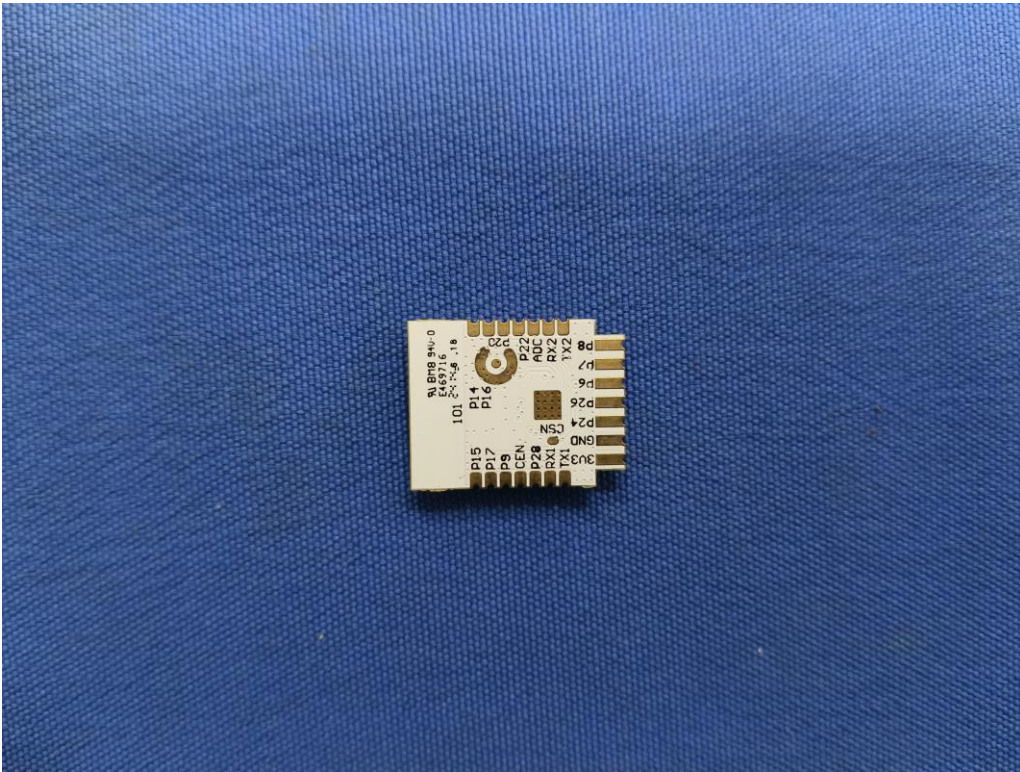
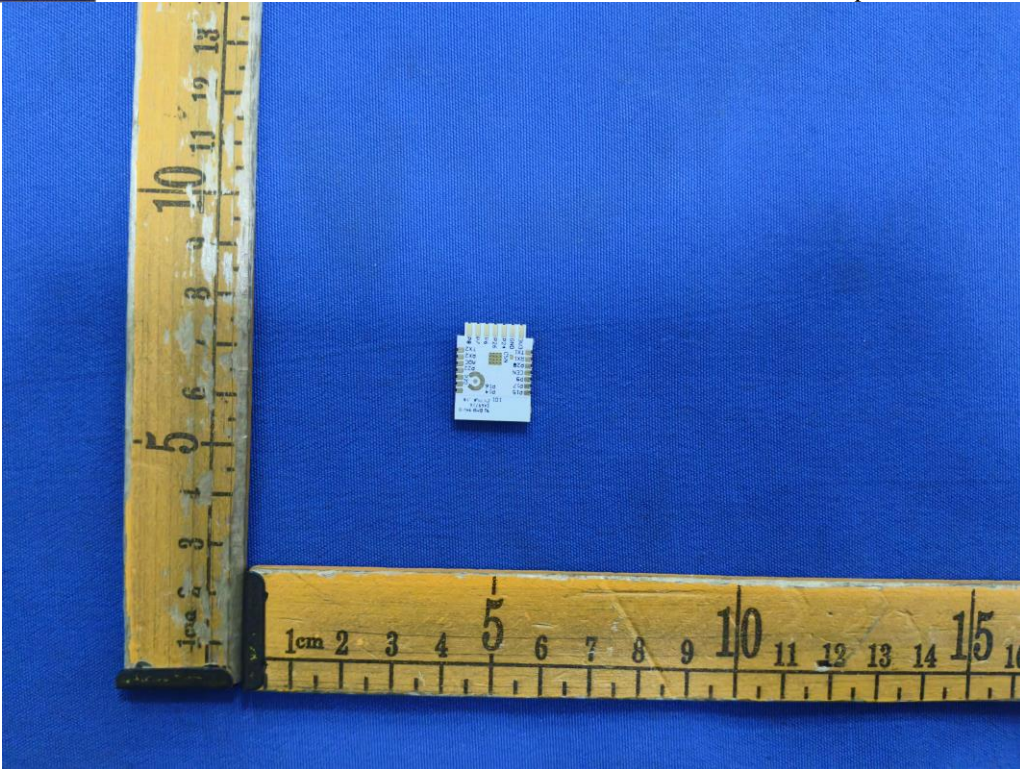

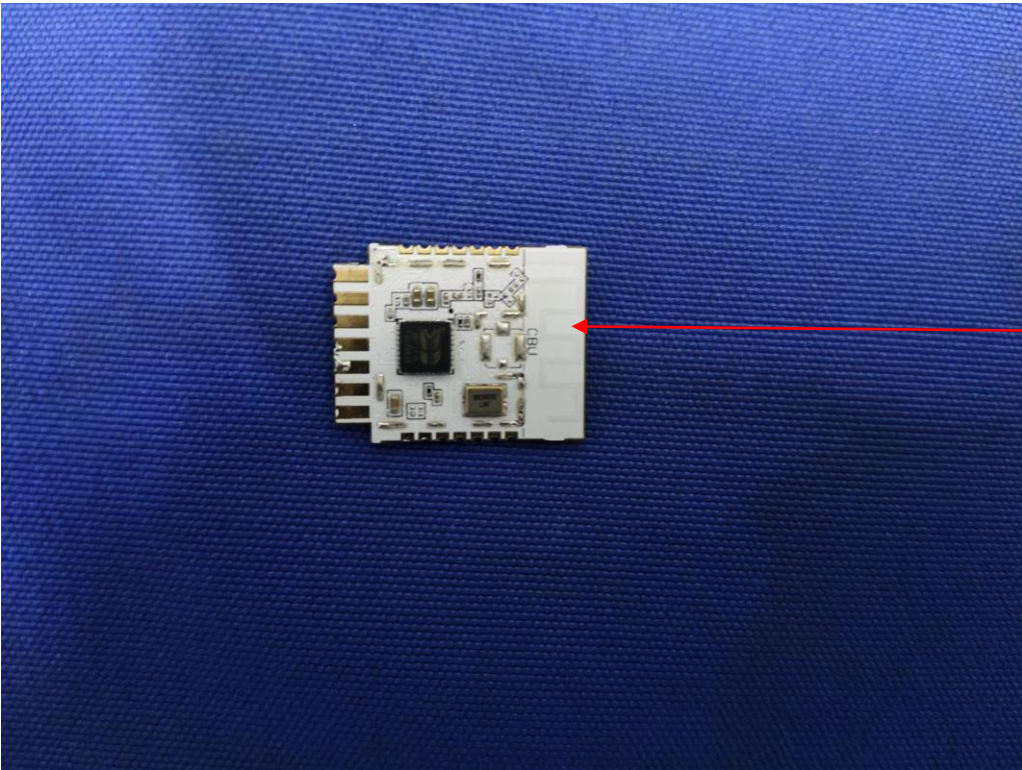
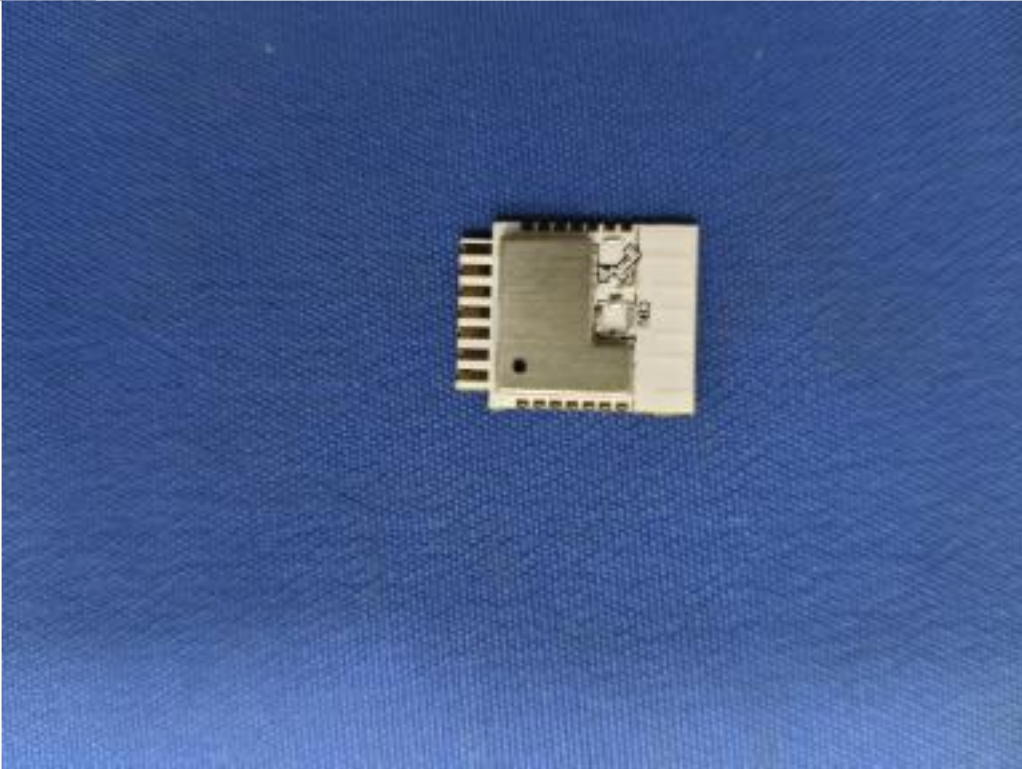

Antenna

--END OF REPORT--