

承認書

SPECIFICATION FOR APPROVAL

客戶:	海芯
CUSTOMER:	
客戶料號:	
CUST P/N:	
音澤料號:	G43.5*0.75-20.5-0.08*48P-10TS-6.5UH-L210MM+BJ
FINE P/N:	
產品型號:	Φ43.5MMX0.75MM
DESC:	
日期:	2024/05/24
DATE:	
版本:	A.0
Version:	

擬制 PREPARED BY	審核 CHECKED BY	批准 APPROVED BY	客戶承認 CUSTOMER APPROVE
何立成	马莉	但可清	

东莞市音泽电子科技有限公司

工廠地址：东莞市茶山镇兴韩路（创富中心城）2栋901号

但可清 TEL: 18617251159

版本變更履歷

SPECIFICATION

產品型號: DESC	G43.5*0.75-20.5-0.08*48P-10 TS-6.5UH-L210MM+BJ	版本 Rev: A.0	客戶 CUST: 客戶料号 CUST P/N:	海芯
---------------	---	----------------	----------------------------	-----------

一、尺寸 DIMENSION:(mm)

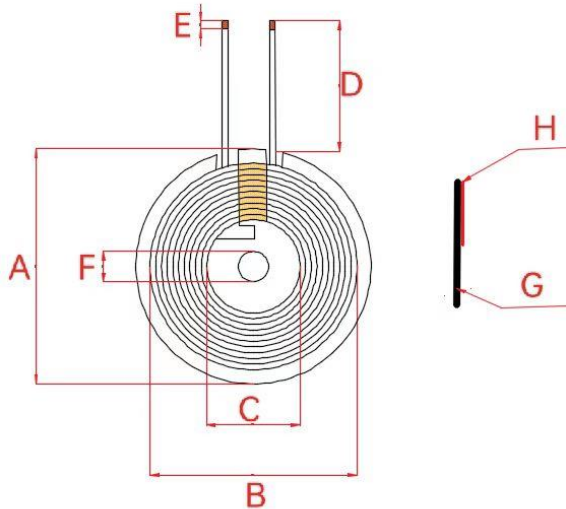

A	43.5±0.5
B	38.3±0.5
C	20.5±0.5
D	210 ±2
E	3±2
F	5.3±0.2
G	0.75±0.05
H	1.65±0.1
I	
K	

二、天线增益 Antenna gain:

Operation frequency:	113kHz-205kHz
Antenna Type:	Loop coil Antenna
Antenna gain:	0dBi

Note:

1. Cross out wire;
2. The coil is attached to the double-slot magnetic disc, the magnetic disc size is 43.5±0.5mm, and the thickness is 0.75±0.05mm.
3. Glue the back of the magnetic disc

三、绕线参数 Winding Specification:

序号 NO.	端子 TERMINAL	线径 WIRE	圈数 Turns	绕线方向 Winding Direction
1	S F	Hot air cable 0.08*48P	10Ts	CCW

四、电气特性 ELECTRICAL CHARACTERISTICS:

温度 TEMPERATURE:25±10℃, 湿度 RELATIVE HUMIDITY:65±20%

序号 NO.	项目 ITEM	端子 TERMINAL	标准 SPECIFICATION	测试条件 TEST FREQUENCY	测试仪器 TEST EQUIPMENTS
1	IND.	S-F	3.7uH ±10% Individual coil	100KHz/1.0V	LCZ METER 1062B
2	IND.	S-F	6.5uH ±10% Magnetized sheet	100KHz/1.0V	LCZ METER 1062B
3	DCR	S-F	≤100mΩ		LCZ METER 502B

擬制/日期 PREPARED BY/DATE 何立成 2024.05.24	審核/日期 CHECKED BY/DATE
--	-----------------------