

# 承认书

## SPECIFICATION FOR APPROVAL

客户名称 (CUSTOMER) 东莞市波力宝科技有限公司

客户料号 (CUSTOMER P/N) :

品名 (DESCRIPTION): DATE: 2024-6-5

规格 (SPECIFICATION): G43.5开槽+背胶27mm磁吸线圈 REV.NO.: A0

### 鸿日昇威科技承认签核、盖章

部门	确认/日期	审核/日期	批准/日期	(盖公司公章)
品质	董晚红 <sub>2024-6-5</sub>	吕惠 <sub>2024-6-5</sub>	韦函满 <sub>2024-6-5</sub>	
工程	何伟华 <sub>2024-6-5</sub>	韦立红 <sub>2024-6-5</sub>	韦立红 <sub>2024-6-5</sub>	

备注:

### 东莞市波力宝科技有限公司 承认签核、盖章

部门	确认/日期	审核/日期	批准/日期	(盖公司公章)
开发工程师				
采购				
品质				

备注:

深圳市鸿日昇威科技有限公司

HRSW ELECTRONICS CO.,LTD

ADD: 深圳市龙华新区观澜环观中路48号1栋2楼

TEL: +86-755-23461055 FAX: +86-0755-28015170

page: 1/3

# SPECIFICATION FOR APPROVAL

## 1. MECHANICAL DIMENSION (UNIT:mm)

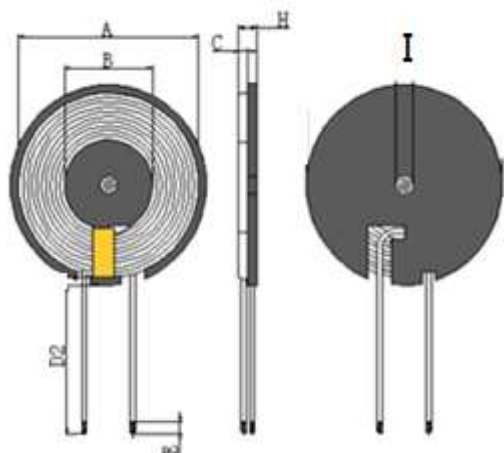

## 2. SCHEMATICS:

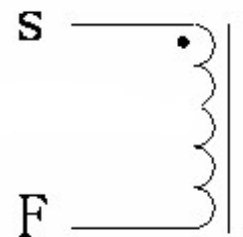

1. 线圈贴磁片，磁片尺寸  
43.5±1mm，  
开L线槽。
2. 线圈出线位置  
缠胶纸 1-2Ts；
3. 磁片背面需加背胶

A	B	C	D2	E	H	F
43.5±1.0	13.5±0.5	0.8±0.05	24±3	4±2	2.2Max	8±0.05

## 3. WINDING:

STEP	START-FINISH	WIRE TYPE	TURNS	TAPE	REMARK
N1	S-F	热风线 $\phi$ 0.08*24mm *2P 2UEW	12TS (Ref)		

## 4. ELECTRICAL SPECIFICATION:

ITEM	L	DCR	Q值	HI-POT
TEST	线圈加磁片	S-F		
CON	100KHz, 0.25V	AT 25°C		
SPEC	7.0uH±10%	130m $\Omega$ Max		

## 5. BILF OF MATERIAL:

NO.	ITEM	MATERIAL SPECIFICATION	MANUFACTURER	SGS NO.
1	热风线	热风线0.08*24股	NANJINGJINNINGCO,LTD	
2	无铅锡条	无铅锡条	QIAODO	
3	磁片	$\phi$ 43.5*0.8锰锌硬磁片开L槽	TAIYI CO.,LTD	
4	胶水	黄胶9999	LIANCHENG CO.,LTD	
5	背胶	41.8*0.05	CUDAK CO.,LTD	
6	高温胶纸	8mm宽高温胶纸	CUDAK CO.,LTD	

HRSW ELECTRONICS CO.,LTD	PART NO	
	TITLE	G43.5开槽+背胶27mm磁吸线圈
DRAWN BY	CHECKED BY	APPROVED BY
何伟华	韦立红	韦立红

# SPECIFICATION FOR APPROVAL

6. SAMPLE TEST DATA									
6.1 DIMENSION TEST (UNIT: mm)									
TEST ITEM	A	B	C	D	E	H	F		
SPEC	43.5±1.0	13.5±0.5	0.8±0.05	24±3	4±2	2.2Max	8.0±0.05		
1	43.26	13.54	0.81	24.3	3.50	1.60	8.01		
2	43.32	13.59	0.82	23.6	3.60	1.50	8.02		
3	43.52	13.58	0.84	24.1	3.70	1.62	7.99		
4	43.62	13.6	0.79	24.5	3.80	1.70	7.98		
5	43.48	13.59	0.83	23.9	4.00	1.82	8.01		
6									
7									
8									
9									
10									
MAX	43.62	13.60	0.84	24.50	4.00	1.82	8.02		
MIN	43.26	13.54	0.79	23.60	3.50	1.50	7.98		
AVERAGE	43.44	13.58	0.82	24.08	3.72	1.65	8.00		
6.2 ELECTRICAL TEST									
TEST ITEM	L		DCR	IDC		Q	HI-POT		
	S-F		S-F						
TEST COND	100KHz/0.25v		AT 25°C						
SPEC	7.0uH ±10%		130mΩ (Max)						
1	6.92		92.00						
2	6.97		93.00						
3	7.00		92.50						
4	7.02		93.10						
5	6.98		92.80						
6									
7									
MAX	7.02		93.10						
MIN	6.92		92.00						
AVERAGE	6.98		92.68						
HRSW ELECTRONICS CO., LTD					PART NO				
					TITLE		G43.5开槽+背胶27mm磁吸线圈		
DRAWN BY			CHECKED BY			APPROVED BY			
何伟华			韦立红			韦立红			