



FCC TEST REPORT

For

Ningbo Dengwei Keji Chuangxin Youxiangongsi

Denvix PowerX Power Bank

Test Model: PowerX

Prepared for : Ningbo Dengwei Keji Chuangxin Youxiangongsi
Address : Lingqiaolu768hao, Zhishigongyuanlianhebangong6louD22 Ningbo, Haishuqu, Zhejiang 315000 CN

Prepared by : Shenzhen LCS Compliance Testing Laboratory Ltd.
Address : 101, 201 Bldg A & 301 Bldg C, Juji Industrial Park Shajing Street, Baoan District, Shenzhen, China

Tel : (+86)755-82591330
Fax : (+86)755-82591332
Web : www.LCS-cert.com
Mail : webmaster@LCS-cert.com

Date of receipt of test sample : October 09, 2024
Number of tested samples : 2
Sample No. : A240920061-1(Engineer sample), A240920061-2(Normal sample)
Date of Test : October 09, 2024 ~ October 17, 2024
Date of Report : October 18, 2024



Shenzhen LCS Compliance Testing Laboratory Ltd.
Add: 101, 201 Bldg A & 301 Bldg C, Juji Industrial Park Yabianxueziwei, Shajing Street, Baoan District, Shenzhen, 518000, China
Tel: +(86) 0755-82591330 | E-mail: webmaster@lcs-cert.com | Web: www.lcs-cert.com
Scan code to check authenticity



FCC TEST REPORT
KDB 680106 D01 Wireless Power Transfer v04

Report Reference No. : LCSA09204155EB

Date of Issue : October 18, 2024

Testing Laboratory Name : Shenzhen LCS Compliance Testing Laboratory Ltd.

Address : 101, 201 Bldg A & 301 Bldg C, Juji Industrial Park Shajing Street, Baoan District, Shenzhen, China

Testing Location/ Procedure : Full application of Harmonised standards
Partial application of Harmonised standards
Other standard testing method

Applicant's Name : Ningbo Dengwei Keji Chuangxin Youxiangongsi

Address : Lingqiaolu768hao, Zhishigongyuanlianhebangong6louD22 Ningbo, Haishuqu, Zhejiang 315000 CN

Test Specification

Standard : FCC CFR 47 PART 1, § 1.1310
KDB 680106 D01 Wireless Power Transfer v04

Test Report Form No. : LCSEMC-1.0

TRF Originator : Shenzhen LCS Compliance Testing Laboratory Ltd.

Master TRF : Dated 2023-12

Shenzhen LCS Compliance Testing Laboratory Ltd. All rights reserved.

This publication may be reproduced in whole or in part for non-commercial purposes as long as the Shenzhen LCS Compliance Testing Laboratory Ltd. is acknowledged as copyright owner and source of the material. Shenzhen LCS Compliance Testing Laboratory Ltd. takes no responsibility for and will not assume liability for damages resulting from the reader's interpretation of the reproduced material due to its placement and context.

EUT Description. : Denvix PowerX Power Bank

Trade Mark : Denvix

Test Model : PowerX

Ratings : USB-C1/C2 Input: 5V, 9V, 15V, 20V, 28V
USB-C1/C2 Output: 5V, 9V, 15V, 20V, 28V
USB-A Output: 5V, 9V, 12V
Wireless: 5W, 7.5W, 10W, 15W
DC 3.65V by Rechargeable Li-ion Battery, 25000mAh

Result : Positive

Compiled by:

Joker.Hu

Supervised by:

Cary Luo

Approved by:

Gavin Liang

Joker Hu/ Administrator

Cary Luo/ Technique principal

Gavin Liang/ Manager



Shenzhen LCS Compliance Testing Laboratory Ltd.
Add: 101, 201 Bldg A & 301 Bldg C, Juji Industrial Park Yabianxueziwei, Shajing Street, Baoan District, Shenzhen, 518000, China
Tel: +(86) 0755-82591330 | E-mail: webmaster@lcs-cert.com | Web: www.lcs-cert.com
Scan code to check authenticity



FCC -- TEST REPORT

Test Report No. : LCSA09204155EB	<u>October 18, 2024</u> Date of issue
---	--

Test Model.....	: PowerX
EUT.....	: Denvix PowerX Power Bank
Applicant.....	: Ningbo Dengwei Keji Chuangxin Youxiangongsi
Address.....	: Lingqiaolu768hao, Zhishigongyuanlianhebangong6louD22 Ningbo, Haishuqu, Zhejiang 315000 CN
Telephone.....	:
Fax.....	:
Manufacturer.....	: Ningbo Soyar Electronic Equipment Co., Ltd.
Address.....	: 3A-9, Building B, No. 528 Dongqing Road, Ningbo High-tech Zone, Zhejiang
Telephone.....	:
Fax.....	:
Factory.....	: Ningbo Soyar Electronic Equipment Co., Ltd.
Address.....	: 3A-9, Building B, No. 528 Dongqing Road, Ningbo High-tech Zone, Zhejiang
Telephone.....	:
Fax.....	:

Test Result	Positive
--------------------	-----------------

The test report merely corresponds to the test sample.

It is not permitted to copy extracts of these test result without the written permission of the test laboratory.



Shenzhen LCS Compliance Testing Laboratory Ltd.
 Add: 101, 201 Bldg A & 301 Bldg C, Juji Industrial Park Yabianxueziwei, Shajing Street, Baoan District, Shenzhen, 518000, China
 Tel: +(86) 0755-82591330 | E-mail: webmaster@lcs-cert.com | Web: www.lcs-cert.com
 Scan code to check authenticity



Revision History

Revision	Issue Date	Revisions	Revised By
000	October 18, 2024	Initial Issue	--



Shenzhen LCS Compliance Testing Laboratory Ltd.
Add: 101, 201 Bldg A & 301 Bldg C, Juji Industrial Park Yabianxueziwei, Shajing Street,
Baoan District, Shenzhen, 518000, China
Tel: +(86) 0755-82591330 | E-mail: webmaster@lcs-cert.com | Web: www.lcs-cert.com
Scan code to check authenticity



TABLE OF CONTENTS

- 1. GENERAL INFORMATION 6**
 - 1.1. DESCRIPTION OF DEVICE (EUT) 6
 - 1.2. SUPPORT EQUIPMENT LIST 6
 - 1.3. EXTERNAL I/O CABLE 6
 - 1.4. DESCRIPTION OF TEST FACILITY 6
 - 1.5. TEST EQUIPMENT 6
 - 1.6. MEASUREMENT UNCERTAINTY 7
 - 1.7. DESCRIPTION OF TEST MODES 7
 - TEST MODES 7
 - 1.8. COIL DESCRIPTION 7
 - 1.9. COIL SIZE 8
 - 1.10. COIL SPECIFICATIONS 8
- 2. TEST METHODOLOGY 9**
 - 2.1. REFERENCE EVALUATION METHOD 9
 - 2.2. LIMIT 10
 - 2.3. TEST SETUP DIAGRAM 10
 - 2.4. MEASUREMENT PROCEDURE 11
 - 2.5. EQUIPMENT APPROVAL CONSIDERATIONS OF KDB 680106 D01v04 11
- 3. TEST RESULTS 12**
 - 3.3. CONCLUSION 16
- 4. TEST SETUP PHOTOS 17**





1. GENERAL INFORMATION

1.1. Description of Device (EUT)

EUT : Denvix PowerX Power Bank

Test Model : PowerX

Ratings : USB-C1/C2 Input: 5V==3A, 9V==3A, 15V==3A, 20V==5A, 28V==5A
 USB-C1/C2 Output: 5V==3A, 9V==3A, 15V==3A, 20V==5A, 28V==5A
 USB-A Output: 5V==3A, 9V==3A, 12V==3A
 Wireless: 5W, 7.5W, 10W, 15W
 DC 3.65V by Rechargeable Li-ion Battery, 25000mAh

Hardware Version : V1.0

Software Version : V1.0

Wireless Charging :

Operating Frequency : 110.0~205.0KHz

Modulation Type : ASK

Antenna Type : Coil Antenna

1.2. Support equipment List

Manufacturer	Description	Model	Serial Number	Certificate
HONOR	Phone	V30Pro	---	FCC
SHENZHEN TIANYIN ELECTRONICS CO., LTD	Power Adapter	TPA-46050200UU	---	FCC

Note: Auxiliary equipment is provided by the laboratory.

1.3 External I/O Cable

I/O Port Description	Quantity	Cable
USB Port	1	N/A
Type-C USB Port	2	N/A

1.4. Description of Test Facility

NVLAP Accreditation Code is 600167-0.
 FCC Designation Number is CN5024
 CAB identifier is CN0071.
 CNAS Registration Number is L4595.
 Test Firm Registration Number: 254912.
 The 3m-Semi anechoic test site fulfils CISPR 16-1-4 according to ANSI C63.4:2014 and CISPR 16-1-4:2010 SVSWR requirement for radiated emission above 1GHz.

1.5. Test Equipment

Equipment	Manufacturer	Model	Serial no.	Calibrated date	Calibrated Due
Exposure Level Tester	Narda	ELT-400	N-0713	2023-10-18	2024-10-17
B-Field Probe	Narda	100cm ²	M-1154	2023-10-18	2024-10-17



Shenzhen LCS Compliance Testing Laboratory Ltd.
 Add: 101, 201 Bldg A & 301 Bldg C, Juji Industrial Park Yabianxueziwei, Shajing Street, Baoan District, Shenzhen, 518000, China
 Tel: +(86) 0755-82591330 | E-mail: webmaster@lcs-cert.com | Web: www.lcs-cert.com
 Scan code to check authenticity



Exposure Level Tester ELT-400 detailed parameters are as follows:

Common parameter	
Operating temperature	-10 °C ~ +50 °C
Operation humidity	< 95 % (30 °C) or < 29 g/m ³
Weight	910 g
Size	180 mm x 100 mm x 55 mm(Main engine) / 290 mm x 125 mm Ø (Probe)
Display	LCD backlit display, 4 refresh rates per second
Battery	Nimh battery (4 x Mignon, AA), rechargeable
Operating time, typical	12 h
Power supply	100 ~240 V AC / 47 ~ 63 Hz
Charging time, typical	2 hours
Recommended calibration cycle	24 months
Country of origin	Germany

1.6. Measurement Uncertainty

Test Item	Frequency Range	Uncertainty	Note
Field Strength Uncertainty	1Hz~400KHz	1%	(1)

(1). This uncertainty represents an expanded uncertainty expressed at approximately the 95% confidence level using a coverage factor of k=2.

1.7. Description of Test Modes

Equipment under test was operated during the measurement under the following conditions:

Charging and communication mode

Test Modes		
Mode 1	AC/DC Adapter(5V/3A) +EUT + mobile phone (Battery Status: <1%)	Record
Mode 2	AC/DC Adapter(5V/3A) +EUT + mobile phone (Battery Status: <50%)	Record
Mode 3	AC/DC Adapter(5V/3A) +EUT + mobile phone (Battery Status: <100%)	Record
Mode 4	AC/DC Adapter(9V/3A) + EUT + mobile phone (Battery Status: <1%)	Pre-tested
Mode 5	AC/DC Adapter(9V/3A) + EUT + mobile phone (Battery Status: <50%)	Pre-tested
Mode 6	AC/DC Adapter(9V/3A) + EUT + mobile phone (Battery Status: <100%)	Pre-tested
Mode 7	AC/DC Adapter(12V/3A) + EUT + mobile phone (Battery Status: <1%)	Pre-tested
Mode 8	AC/DC Adapter(12V/3A) + EUT + mobile phone (Battery Status: <50%)	Pre-tested
Mode 9	AC/DC Adapter(12V/3A) + EUT + mobile phone (Battery Status: <100%)	Pre-tested

Note: All test modes were pre-tested for ac and dc mode, but we only recorded the worst case in this report for ac mode.

1.8. Coil Description

Config.	Mode	Descriptions
1	Standby (Flatbed Position) @134kHz	EUT Alone powered by AC/DC adapter
2	Operating (Flatbed Position) (Phone @134kHz, ~10%, 20~50%, and >75% Power Charging)	EUT with lightning to AC/DC Adapter & Wireless Charging to WPT Client. 15W: Direct Contact 15W: 2mm Airgap, 2mm Shift Top as Worst-Case Position



1.9. Coil Size

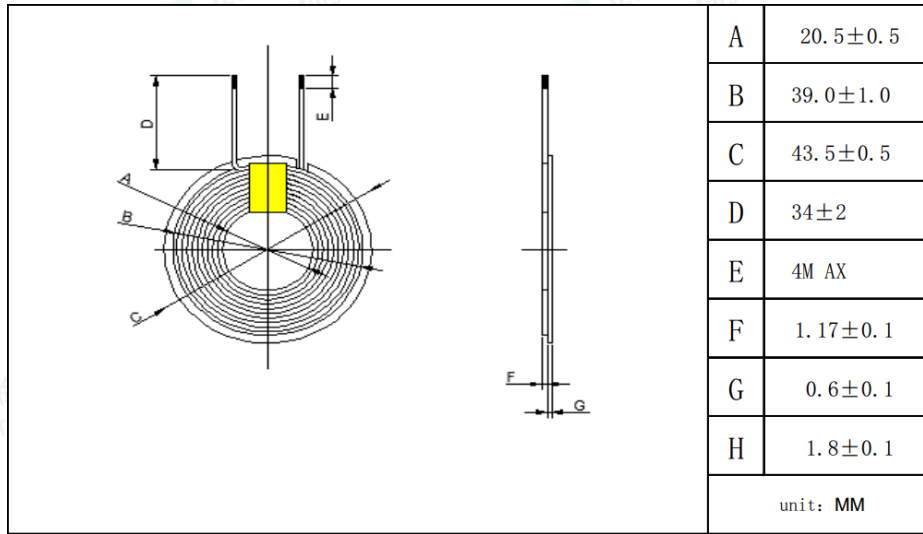

(Unit: mm)

1.10. Coil Specifications

Item	Parameter
Input inductance:	Transmitter 1: 6.5 μH±10%
Material of enclosure(s):	Multiple strands of enamelled wire
Number of turns:	Transmitter 1: 10 turns





1.11. Duty Cycle

Mode	ON Time (ms)	Period (ms)	Duty Cycle (%)
Operating (110.0-205kHz)	/	/	100

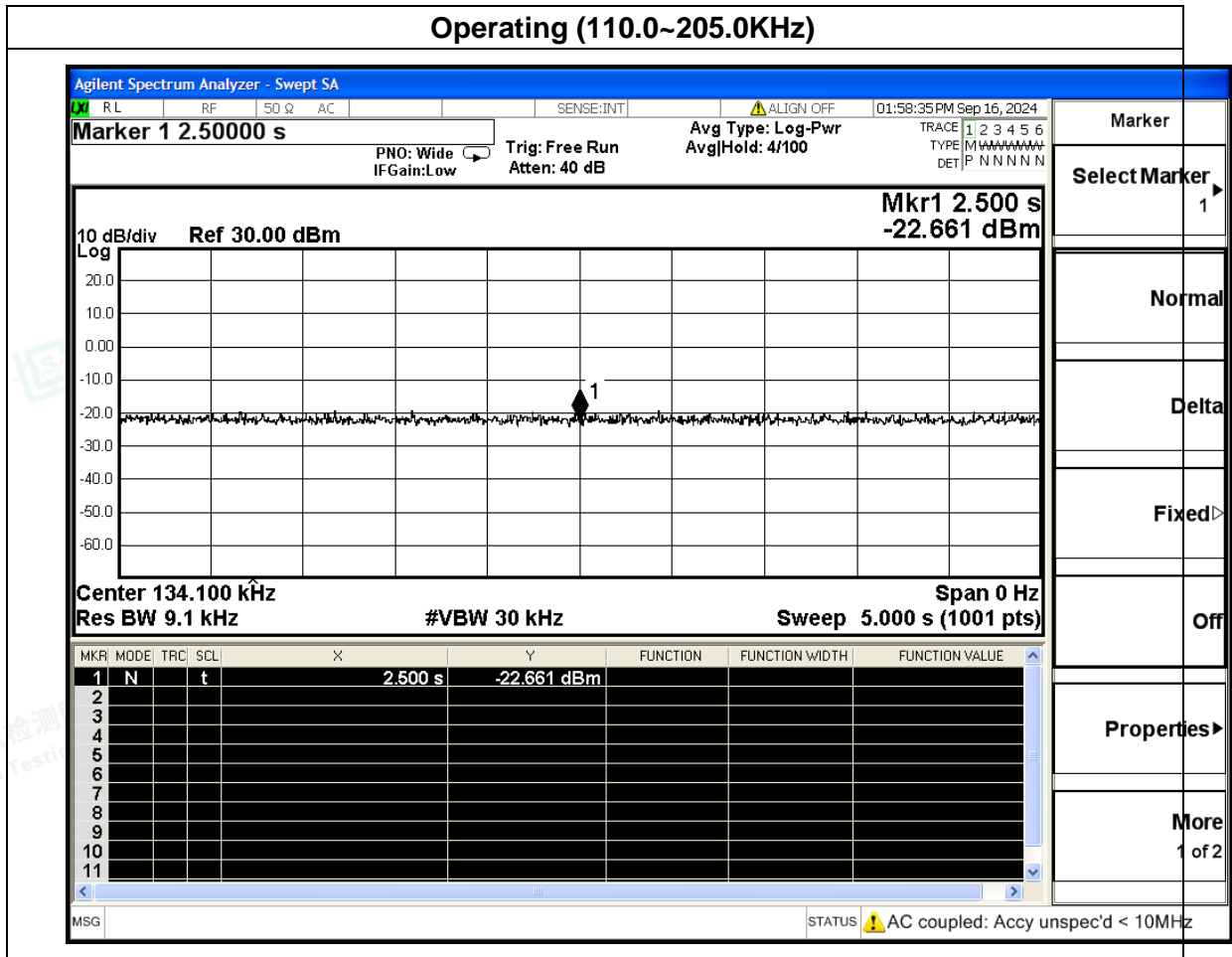

2. TEST METHODOLOGY

2.1. Reference Evaluation Method

ANSI C95.1–1999: IEEE Standard for Safety Levels with Respect to Human Exposure to Radio Frequency Electromagnetic Fields, 3 kHz to 300 GHz.

FCC KDB publication 680106 D01 RF Exposure Wireless Charging Apps v04: RF Exposure Considerations for Low Power Consumer Wireless Power Transfer Applications

FCC CFR 47 part1 1.1310: Radiofrequency radiation exposure limits.

FCC CFR 47 part2 2.1093: Radiofrequency radiation exposure evaluation: portable devices

FCC CFR 47 part 18.107: Industrial, Scientific, and Medical Equipment

April 2024 TCBC Workshop: Part 18 Wireless Power Transfer Devices: Clarifications on KDB 680106v04 and ECR Processes



2.2. Limit

§1.1310: The criteria listed in the following table shall be used to evaluate the environment impact of human exposure to radio frequency (RF) radiation as specified in §1.1307(b), except in the case of portable devices which shall be evaluated according to the provisions of FCC part 2.1093 of this chapter.

Table 1 to §1.1310(e)(1) - Limits for Maximum Permissible Exposure (MPE)

Frequency range (MHz)	Electric field strength (V/m)	Magnetic field strength (A/m)	Power density (mW/cm ²)	Averaging time (minutes)
(i) Limits for Occupational/Controlled Exposure				
0.3-3.0	614	1.63	*(100)	≤6
3.0-30	1842/f	4.89/f	*(900/f ²)	<6
30-300	61.4	0.163	1.0	<6
300-1500	/	/	f/300	<6
1500-100000	/	/	5	<6
(ii) Limits for General Population/Uncontrolled Exposure				
0.3-1.34	614	1.63	*(100)	<30
1.34-30	824/f	2.19/f	*(180/f ²)	<30
30-300	27.5	0.073	0.2	<30
300-1500	/	/	f/1500	<30
1500-100000	/	/	1.0	<30

f = frequency in MHz

* = Plane-wave equivalent power density

Note 1: Occupational/controlled exposure limits apply in situations in which persons are exposed as a consequence of their employment provided those persons are fully aware of the potential for exposure and can exercise control over their exposure.

Note 2: General population/uncontrolled exposure limits apply in situations in which the general public may be exposed, or in which persons who are exposed as a consequence of their employment may not be fully aware of the potential for exposure or cannot exercise control over their exposure.

2.3. Test Setup Diagram

Mobile Exposure Conditions

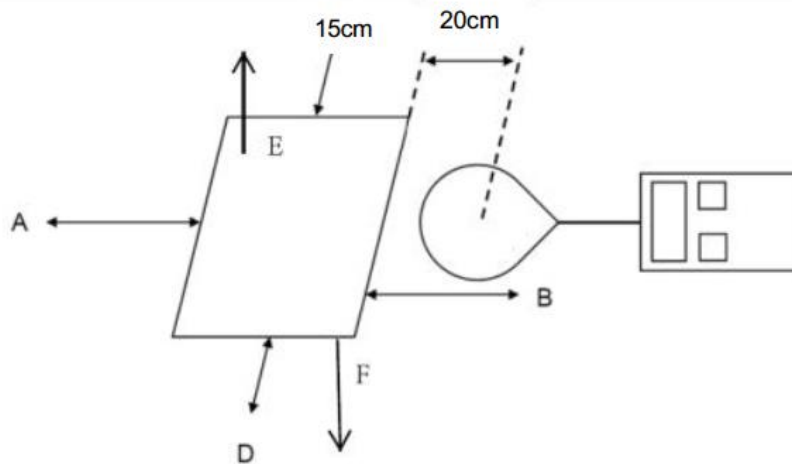

Note: The distance of the points A/B/C/D is 15cm, and the point E is 20cm.

Portable Exposure Conditions:



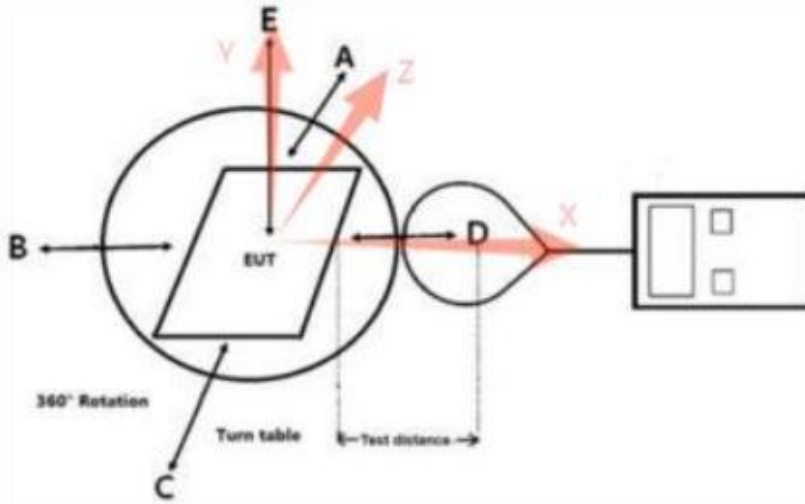

Note: The distance of the points A/B/C/D/E/F is 0,2,4,6,8,10,12,14,16,18, 20cm.
 The values tested by the probe are X, Y, and Z on three axes perpendicular to the edge of the device. Top and bottom side coincident with the axis(Y) of the main coil.

2.4. Measurement Procedure

Mobile Exposure Conditions

- The RF exposure test was performed in anechoic chamber.
- E and H-field measurements should be made with the center of the probe at 15 cm surrounding the EUT and 20 cm above the top surface of the primary/client pair.
- The highest emission level was recorded and compared with limit.
- The EUT was measured according to the KDB 680106 D01 Wireless Power Transfer v04.

Portable Exposure Conditions

- The RF exposure test was performed in anechoic chamber.
- Perform H-field measurements for each edge/top surface of the host/client pair at every 2 cm, starting from as close as possible out to 20 cm
- The highest emission level was recorded and compared with limit.
- The EUT was measured according to the KDB 680106 D01 Wireless Power Transfer v04.

2.5. Equipment Approval Considerations of KDB 680106 D01v04

Requirements of KDB 680106 D01	Yes / No	Description
Power transfer frequency is less than 1 MHz	Yes	The device operates in the frequency range 110 KHz-205KHz
The output power from each transmitting element (e.g., coil) is less than or equal to 15 watts.	Yes	The maximum output power of each primary coil is 15W.
A client device providing the maximum permitted load is placed in physical contact with the transmitter (i.e., the surfaces of the transmitter and client device enclosures need to be in physical contact)	Yes	Client device is placed directly in contact with the transmitter.
Only § 2.1091- Mobile exposure conditions apply (i.e., this provision does not cover § 2.1093-Portable exposure conditions).	No	Mixed mobile and portable exposure conditions
The E-field and H-field strengths, at and beyond 20 cm surrounding the device surface, are	Yes	The E-field and H-field strengths from all simultaneous transmitting coils are





<p>demonstrated to be less than 50% of the applicable MPE limit, per KDB 447498, Table 1. These measurements shall be taken along the principal axes of the device, with one axis oriented along the direction of the estimated maximum field strength, and for three points per axis or until a 1/d (inverse distance from the emitter structure) field strength decay is observed. Symmetry considerations may be used for test reduction purposes. The device shall be operated in documented worst-case compliance scenarios (i.e., the ones that lead to the maximum field components), and while all the radiating structures (e.g., coils or antennas) that by design can simultaneously transmit are energized at their nominal maximum power.</p>		<p>demonstrated to less than 50% of the MPE limit.</p>
<p>For systems with more than one radiating structure, the conditions specified in (5) must be met when the system is fully loaded (i.e., clients absorbing maximum power available), and with all the radiating structures operating at maximum power at the same time, as per design conditions. If the design allows one or more radiating structures to be powered at a higher level while other radiating structures are not powered, then those cases must be tested as well. For instance, a device may use three RF coils powered at 5 W, or one coil powered at 15 W: in this case, both scenarios shall be tested</p>	<p>Yes</p>	<p>Only one radiating structure and tested at maximum Output Power</p>

3. TEST RESULTS

For portable exposure condition

- (1). The portable test modes have covered the considerations of the mobile test, only record the test data of the portable conditions in this report.
- (2) Operating modes with client device (1 %, 50%, 99% battery status of client device) have been test, only show the data of worst case of 1% battery status of client device.
- (3) Test performed with all the radiating structures operating at maximum power at the same time.
- (4) E-Filed and H-field measurements are taken along all three axes the device from 0cm~20cm in 2cm minimum increment for each edge surface of the host/client pair. If the center of the probe sensing element is more than 5mm from the probe outer edge, the field strengths need to be estimated for the positions that are not reachable.
- (5) Validation of Field Estimates
 - (a) If R is the probe radius and the probe tip is in contact with the coil, then the probe center is R cm from the coil surface as bellowing picture



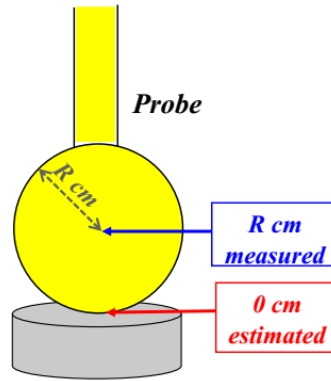

- (b) The probe then is measuring the field correctly at R cm from the surface, and only estimating the field at the 0 cm point of contact with the coil surface.
- (c) The validation requires showing that the model used to estimate the field provides data within 30% accuracy for at least the two, 2-cm-spaced closest points to where the estimates were made.
- (d) If there is only one estimated value, then a single validation point is sufficient.
- (e) Validation Example for 4 cm Probe Radius as following

Step 1

Validation Example for 4 cm Probe Radius

1. Measure the field at 4 cm (closest position)

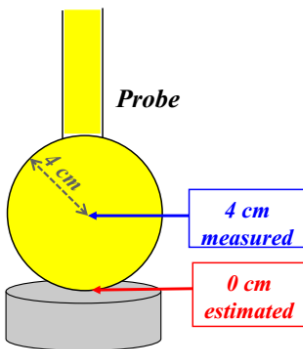

Step 2

2. Position the probe 2 cm from the DUT. Measure the field at 6 cm (probe calibration point)

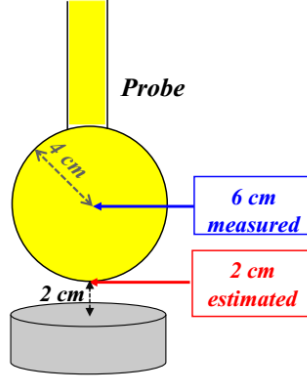

3. Position the probe 4 cm from the DUT. Estimate the field at 4 cm. Compare with Step 1.

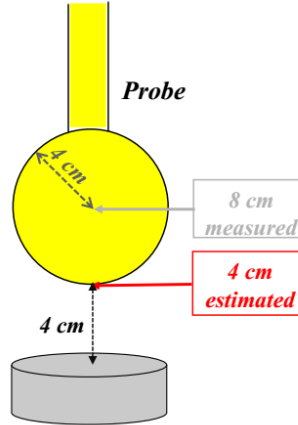

4. Position the probe 6 cm from the DUT. Estimate the field at 6 cm. Compare with Step 2.

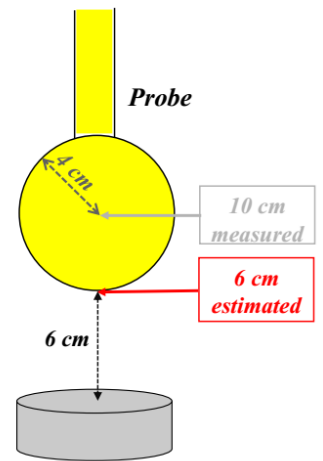

Validation Example for 4 cm Probe Radius

1. Measure the field at 4 cm (closest position)

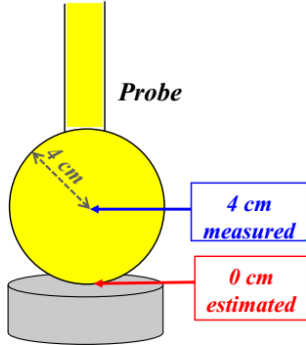

2. Position the probe 2 cm from the DUT. Measure the field at 6 cm (probe calibration point)

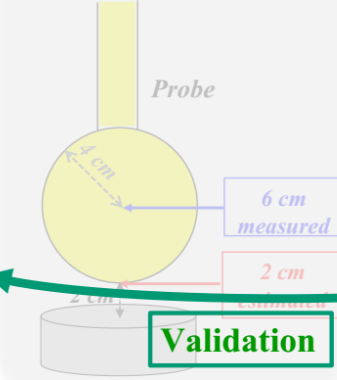

3. Position the probe 4 cm from the DUT. Estimate the field at 4 cm. Compare with Step 1.

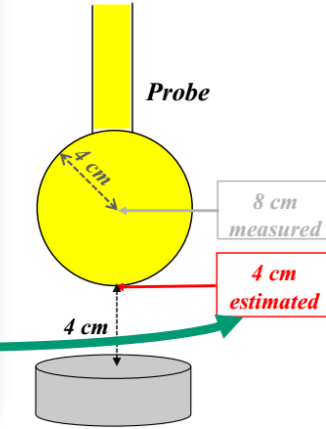

4. Position the probe 6 cm from the DUT. Estimate the field at 6 cm. Compare with Step 2.

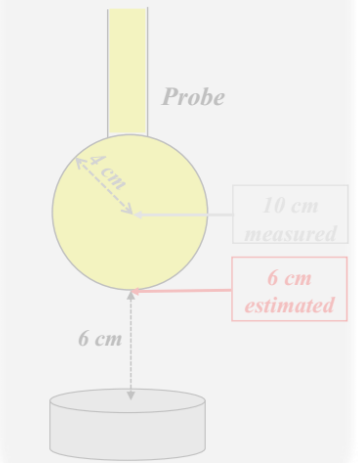

Step 3

Validation Example for 4 cm Probe Radius

1. Measure the field at 4 cm (closest position)

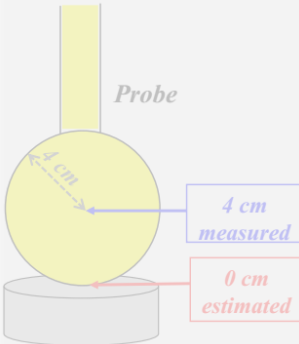

2. Position the probe 2 cm from the DUT. Measure the field at 6 cm (probe calibration point)

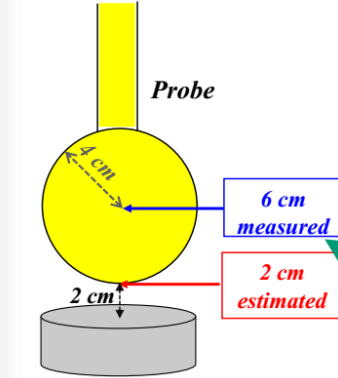

3. Position the probe 4 cm from the DUT. Estimate the field at 4 cm. Compare with Step 1.

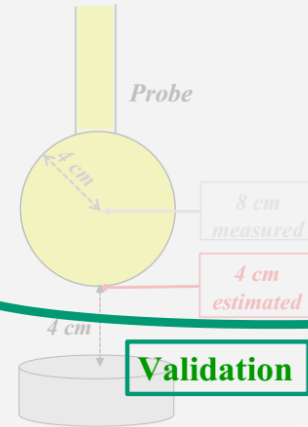

4. Position the probe 6 cm from the DUT. Estimate the field at 6 cm. Compare with Step 2.

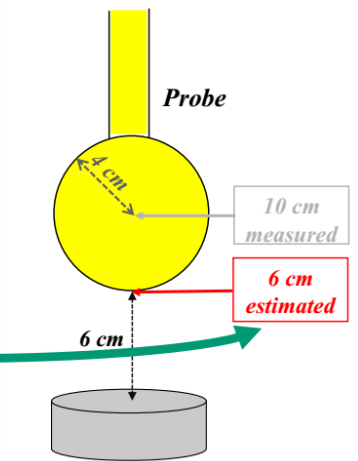

Description of the Validation Example for 4 cm Probe Radius

- Assume that $R=4$ cm. The field at 0 cm can only be estimated, but the field at 4 cm is measured exactly (at the center of the probe).
- Move the probe at 2 cm from the surface. The field at 2 cm can still only be estimated, but the field at 6 cm is measured exactly.
- Compare the estimates with the values at the same positions where the field was measured exactly (i.e., 4 cm and 6 cm)
- The difference between measurements and estimates needs to be no more than 30%.
- That validation of the estimates needs to be for the two closest points to the coil, but at least 2 cm apart (in this case they are). This is to avoid a validation at, say 2 cm and another one at 2.1 cm, that is essentially a repetition





- (6) According to Calibration information and specification about ETL-400 Probe (the B-Field Probe size is 100cm², the probe radius is 5.65cm), The Probe ETL-400 Probe's sensitive elements center is located in the probe's center, and the distance from the sensitive elements center to the tip of probe is 5.65cm.
- (7) The actual 0cm, 2cm, 4cm and 6cm field strengths need to be estimated for the positions that are not reachable via numerical calculation.
- (8) For validation purposes: If the value to show a 30% agreement between the mode and the probe measurements for the two closest points to the device surface, and with 2cm increments. Then this extrapolation method is reasonable.
- (9) Validation E-Field and H-Field as bellowing;

Validation Mode: TM1 H-Field (A/m)			Validation Position: Top	
	Results	Difference Values	Difference Limit	Conclusion
Estimated Distance: 0 cm	0.6726	28.87%	≤ 30%	Compliance
Measured Distance: 5.65 cm	0.5219		≤ 30%	Compliance
Estimated Distance: 2 cm	0.6122	29.32%	≤ 30%	Compliance
Measured Distance: 7.65 cm	0.4734		≤ 30%	Compliance
Estimated Distance: 4 cm	0.5438	25.62%	≤ 30%	Compliance
Measured Distance: 7.65 cm	0.4329		≤ 30%	Compliance

Validation Mode: TM1 E-Field (V/m)			Validation Position: Top	
	Results	Difference Values	Difference Limit	Conclusion
Estimated Distance: 0 cm	37.6345	27.24%	≤ 30%	Compliance
Measured Distance: 5.65 cm	29.5781		≤ 30%	Compliance
Estimated Distance: 2 cm	34.6318	27.98%	≤ 30%	Compliance
Measured Distance: 7.65 cm	27.0817		≤ 30%	Compliance
Estimated Distance: 4 cm	31.4018	29.84%	≤ 30%	Compliance
Measured Distance: 7.65 cm	23.5919		≤ 30%	Compliance

Note 1: The compliance location as probe tip;

Note 2: The format of difference is;

The E Validation Difference = $(E_{\text{Estimated Distance}} - E_{\text{Measured Distance}}) / E_{\text{Measured Distance}} * 100\%$

The H Validation Difference = $(H_{\text{Estimated Distance}} - H_{\text{Measured Distance}}) / H_{\text{Measured Distance}} * 100\%$

H-Field and E-Field Emission level with a combination of measured and estimated results.

Test condition: Mode 1

Distance(cm)	H-Field Result(A/m)							Limit(A/m)
	Type	Top	Bottom	Left	Right	Front	Back	
0	Estimate	0.7706	0.7014	0.6106	0.5869	0.4845	0.5469	1.63
2	Estimate	0.6275	0.6549	0.5119	0.5430	0.4255	0.2779	1.63
4	Estimate	0.6571	0.5779	0.6607	0.5016	0.4036	0.4702	1.63
6	Measured	0.4388	0.5343	0.4330	0.5543	0.3540	0.4201	1.63
8	Measured	0.2386	0.4023	0.3206	0.2654	0.3472	0.2879	1.63
10	Measured	0.1309	0.2405	0.2543	0.1465	0.0758	0.0391	1.63
12	Measured	0.0981	0.0496	0.2255	0.1759	0.0025	0.0456	1.63
14	Measured	0.2674	0.0588	0.1408	0.2264	0.0706	0.1448	1.63
16	Measured	0.1426	0.0895	0.0931	0.1475	0.1176	0.2038	1.63
18	Measured	0.0325	0.0908	-0.0111	-0.0358	0.0720	0.0699	1.63
20	Measured	0.0463	0.0746	0.1023	0.0149	0.0356	0.0488	1.63



Shenzhen LCS Compliance Testing Laboratory Ltd.

Add: 101, 201 Bldg A & 301 Bldg C, Juji Industrial Park Yabianxueziwei, Shajing Street, Baoan District, Shenzhen, 518000, China

Tel: +(86) 0755-82591330 | E-mail: webmaster@lcs-cert.com | Web: www.lcs-cert.com

Scan code to check authenticity



Distance(cm)	E-Field Result(V/m)							Limit(V/m)
	Type	Top	Bottom	Left	Right	Front	Back	
0	Estimate	37.6335	36.2798	36.3402	32.1580	31.7472	31.5789	613
2	Estimate	34.5529	34.3286	34.0231	30.6739	29.6212	29.1675	613
4	Estimate	31.3190	30.8034	31.2866	27.9255	26.9968	26.6113	613
6	Measured	28.8990	26.9029	27.9412	23.7199	22.6709	22.4155	613
8	Measured	24.5976	23.2557	23.8023	20.4621	19.5950	19.2821	613
10	Measured	22.3774	21.2553	21.6285	17.6567	16.1675	16.2261	613
12	Measured	20.1776	19.4857	19.8282	15.3282	13.5657	13.1736	613
14	Measured	17.3071	17.0647	17.1012	13.1320	11.4014	11.2533	613
16	Measured	15.9165	14.8399	15.6581	10.2372	9.1664	9.1693	613
18	Measured	12.7085	11.6912	12.2023	8.2765	7.4023	7.2936	613
20	Measured	7.7421	7.3772	7.6098	5.3061	4.3966	3.8686	613

3.3 Conclusion

A minimum safety distance of 0 cm to the antenna is required when the device is charging a smart phone for portable exposure. The detected emissions are below the limitations according FCC KDB 680106.



Shenzhen LCS Compliance Testing Laboratory Ltd.
 Add: 101, 201 Bldg A & 301 Bldg C, Juji Industrial Park Yabianxueziwei, Shajing Street,
 Baoan District, Shenzhen, 518000, China
 Tel: +(86) 0755-82591330 | E-mail: webmaster@lcs-cert.com | Web: www.lcs-cert.com
 Scan code to check authenticity

4. TEST SETUP PHOTOS

(The separation distance from the geometric center of the probe to the edge of the device is 6.25cm)



0cm-Left

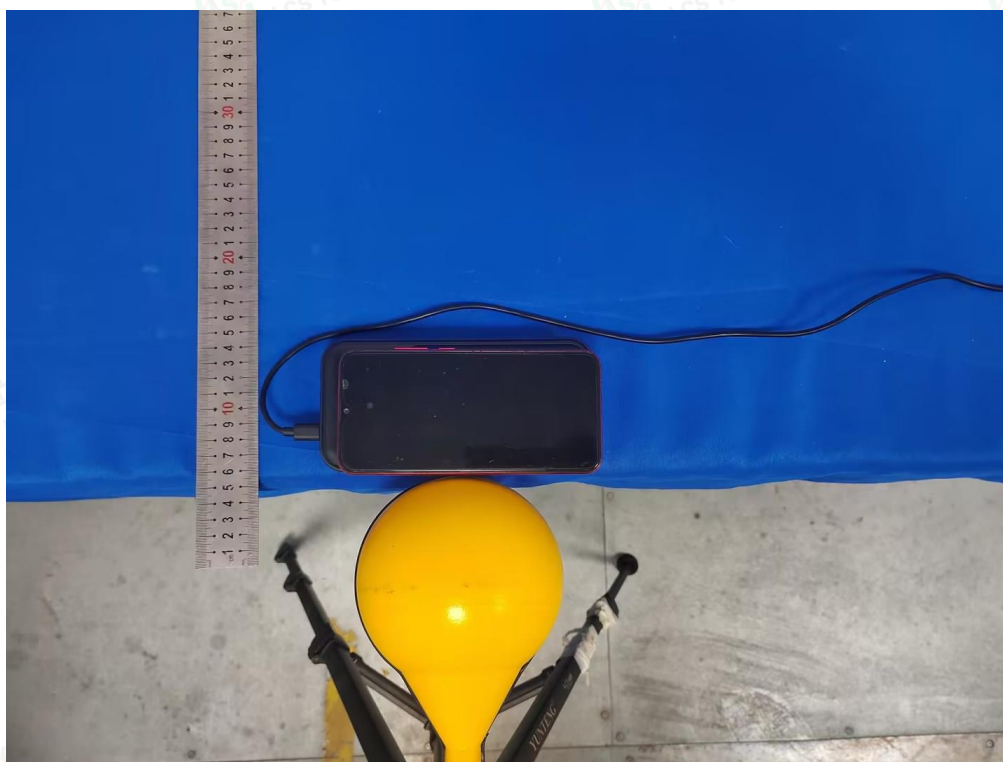

0cm-Right





0cm-Top



0cm-Bottom





0cm-Front

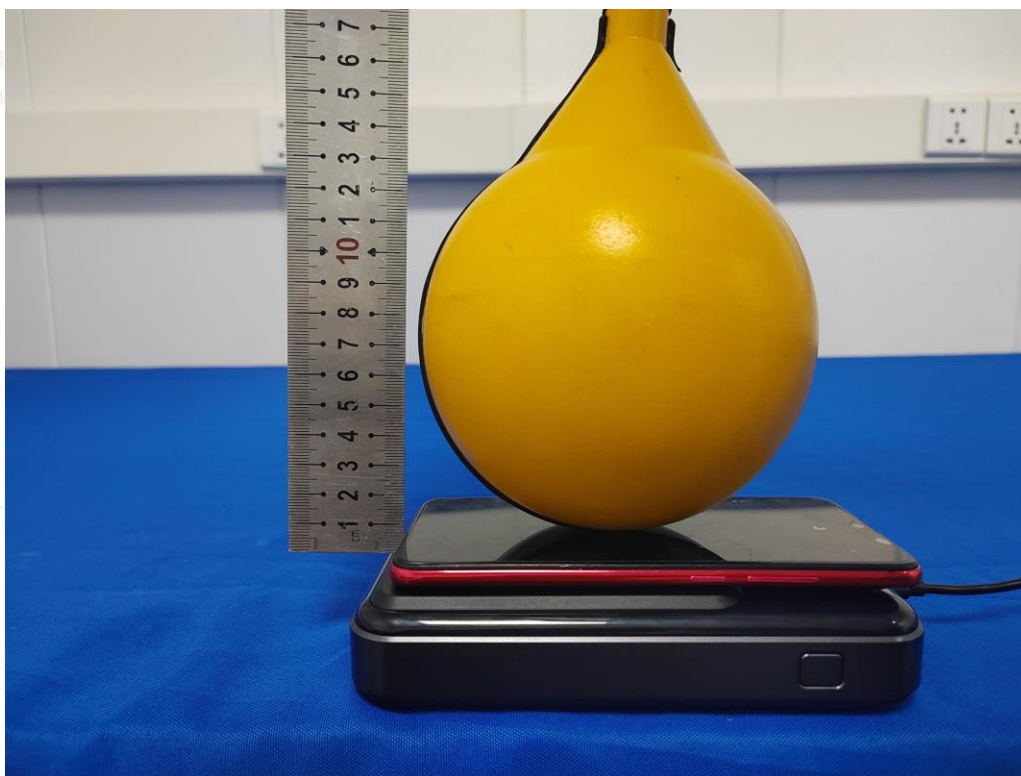

0cm-Back



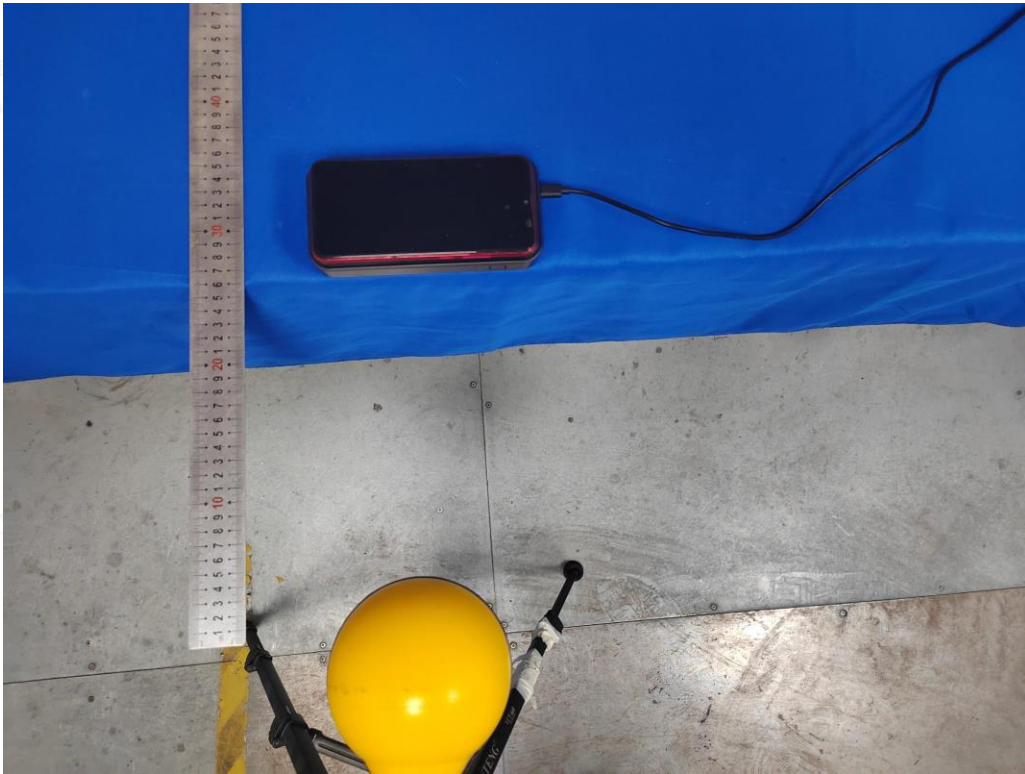

20cm-Left

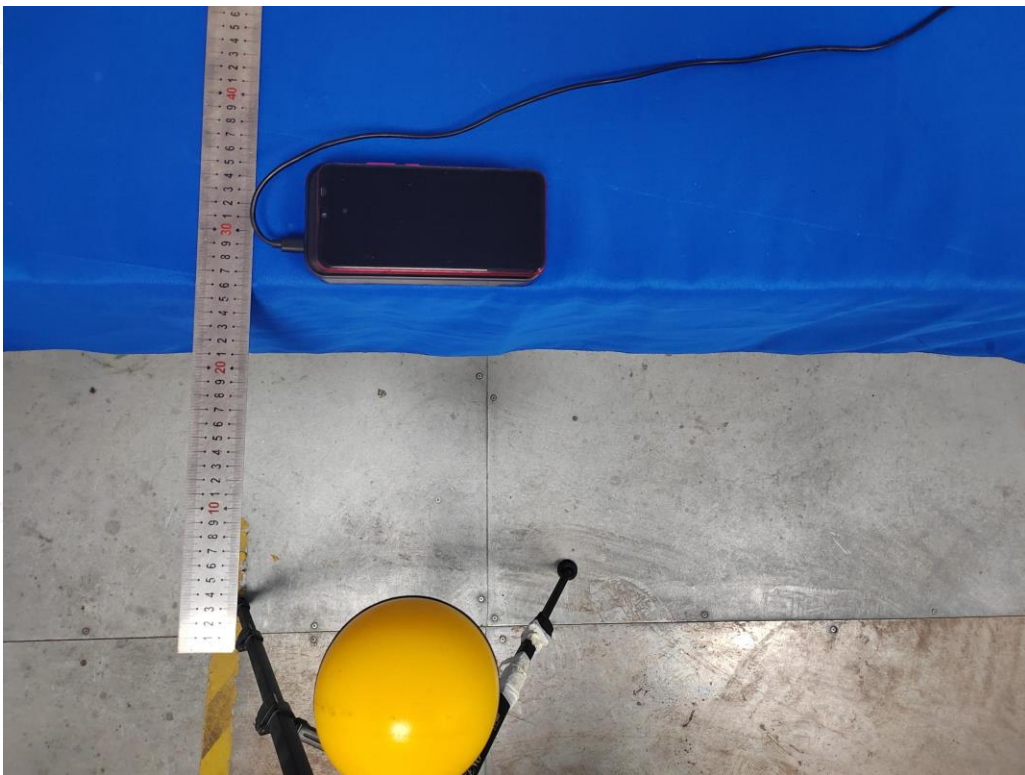

20cm-Right



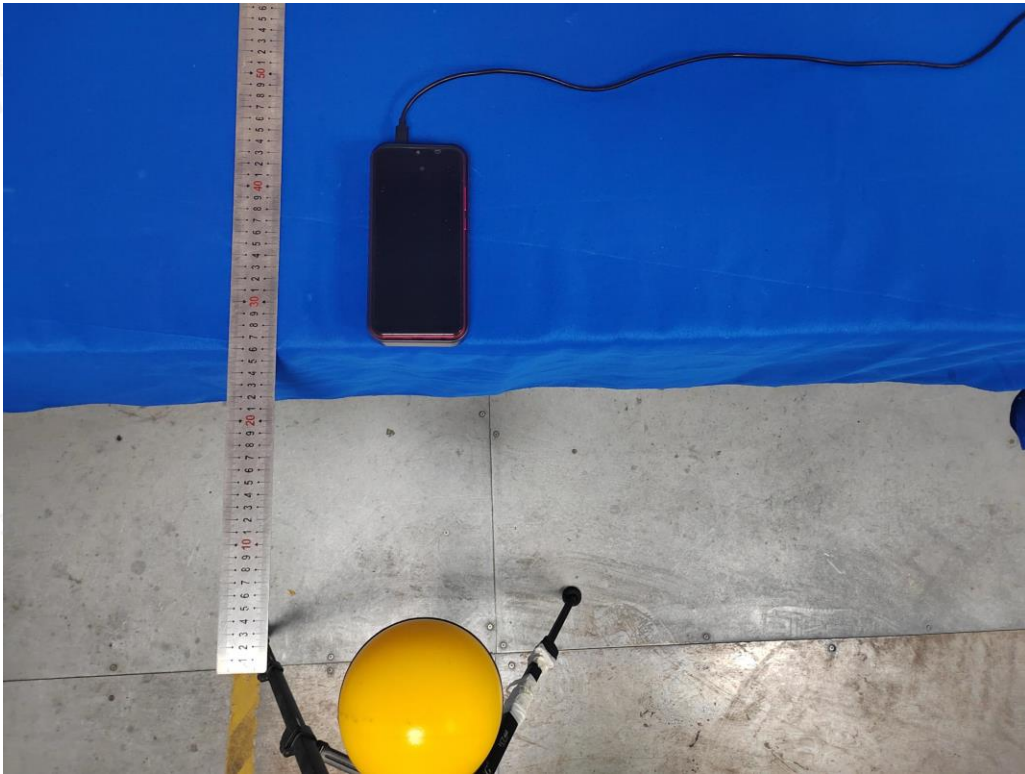

20cm-Top

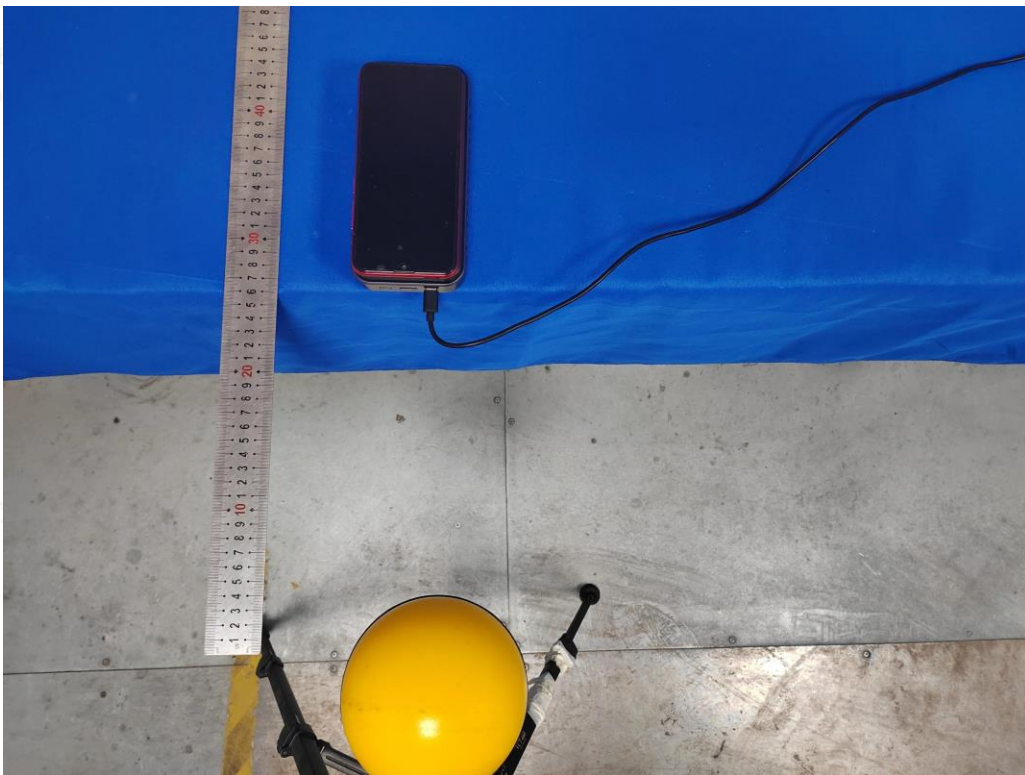

20cm-Bottom



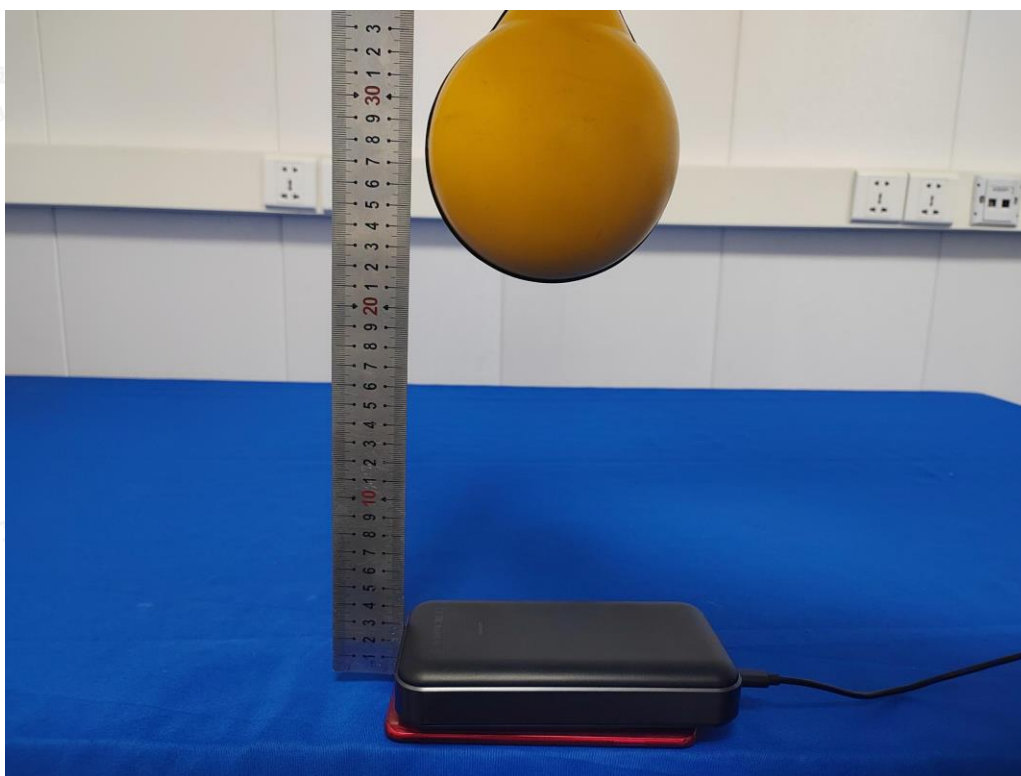

20cm-Front

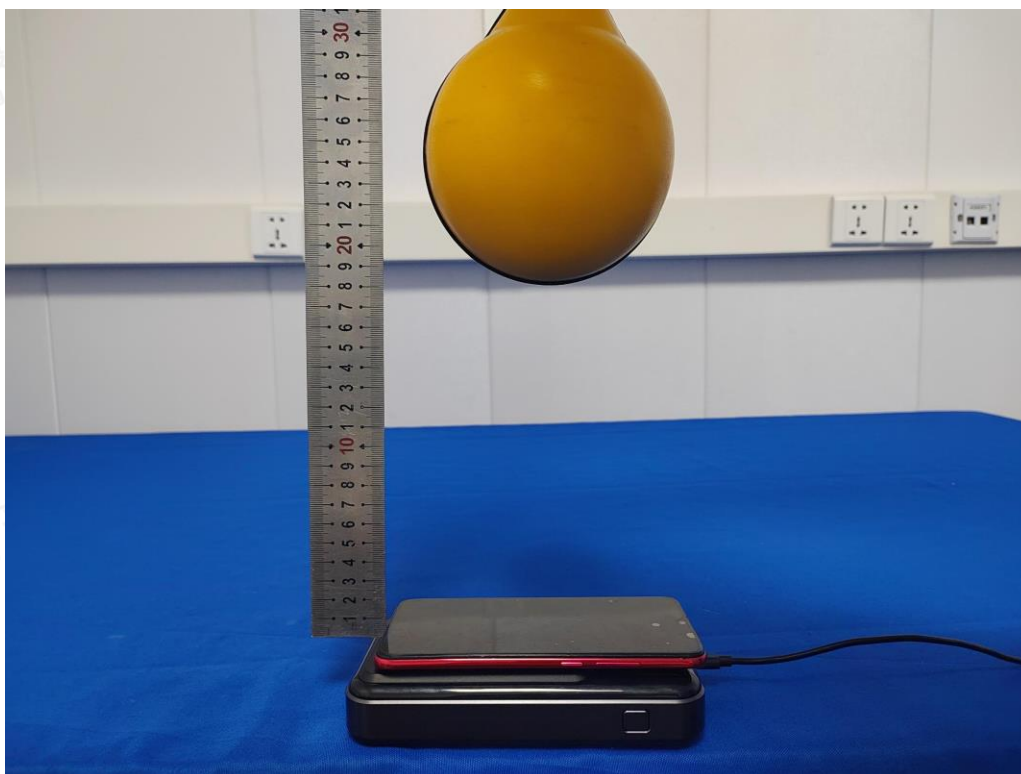

20cm-Back

-----THE END OF REPORT-----

