

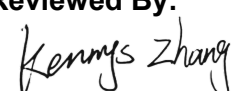

FCC CERTIFICATION TEST REPORT

Applicant:	RAINVI TECHNOLOGIES PRIVATE LIMITED		
Address:	8-2-283/82/A/321/1 HBS CO OP JUBILEE HILLS HYDERABAD, TELANGANA, INDIA - 500034		
Manufacturer:	Guangzhou Yuandong Smart Sports Technology Co., LTD		
Address:	Room 518, 192 Kezhu Road, Huangpu District, Guangzhou		
Product Description:	Portl UltraGym 70		
Brand Name:	NA		
Tested Model:	PUG-70		
FCC ID:	2BKUS-PUG70		
Report No.:	JCF240813051-002		
Received Date:	Aug. 13, 2024		
Tested Date:	Aug. 13, 2024 ~ Sep. 02, 2024		
Issued Date:	Sep. 02, 2024		
Test Standards:	FCC Rules and Regulations Part 15 Subpart C,		
Test Procedure:	ANSI C63.10:2013		
Test Result:	Pass		
Prepared By:	<div style="text-align: center;">  <u>Roger Li/Engineer</u> </div> <div style="text-align: right;"> Date: Sep. 02, 2024 </div>		
Reviewed By:	<div style="text-align: center;">  <u>Kennys Zhang/Engineer</u> </div> <div style="text-align: right;"> Date: Sep. 02, 2024 </div> <div style="text-align: center; margin-top: 10px;">  </div>		
Approved By:	<div style="text-align: center;">  <u>Talent Zhang/Engineer</u> </div> <div style="text-align: right;"> Date: Sep. 02, 2024 </div>		

Note: The test results in this report apply exclusively to the tested model / sample. Without written approval of Guangzhou Jingce Testing Technology Co., Ltd. the test report shall not be reproduced except in full.

Report Revise Record

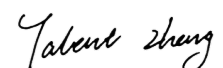
Report Version	Revise Time	Issued Date	Valid Version	Notes
V1.0	/	Sep. 02, 2024	Original Report	/

TABLE OF CONTENTS

1. Test Report Declare	5
2. Summary of Test Results	6
3. Test Laboratory	6
4. Equipment Under Test	7
4.1. Description of EUT	7
4.2. Channel List	7
4.3. Test Channel Configuration	7
4.4. Test environment conditions	8
4.5. The Worse Case Power Setting Parameter	8
4.6. Description of Available Antennas	8
5. Description of Test Setup	8
5.1. Accessory	8
5.2. Support Equipment	8
5.3. Test Setup	8
5.4. Setup Diagram for Tests	8
6. Measurement Uncertainty	9
7. Measuring Instrument and Software Used	9
8. On Time and Duty Cycle	11
8.1. Block diagram of test setup	11
8.2. Limits	11
8.3. Procedure	11
8.4. Results	11
8.5. Original test data	11
9. 6 dB DTS Bandwidth	13
9.1. Block diagram of test setup	13
9.2. Limits	13
9.3. Test Procedure	13
9.4. Results	13
9.5. Original test data	14
10. Peak Conducted Output Power	16
10.1. Block diagram of test setup	16
10.2. Limits	16
10.3. Test Procedure	16
10.4. Results	16
10.5. Original test data	17
11. Power Spectral Density	18
11.1. Block diagram of test setup	18
11.2. Limits	18
11.3. Test Procedure	18
11.4. Results	18
11.5. Original test data	19
12. Conducted Bandedge and Spurious Emissions	20
12.1. Block diagram of test setup	20
12.2. Limits	20
12.3. Test Procedure	20
12.4. Results	20
12.5. Original test data	21
13. Radiated Emission	25
13.1. Block diagram of test setup	25
13.2. Limit	26
13.3. Test Procedure	27
13.4. Results	29

- 13.5. Original test data 29
- 14. AC Power Line Conducted Emissions 30**
 - 14.1. Block diagram of test setup 30
 - 14.2. Limits 30
 - 14.3. Test procedure 30
 - 14.4. Test result 31
 - 14.5. Original test data 31
- 15. Antenna Requirements 32**
 - 15.1. Limits 32
 - 15.2. Result 32
- APPENDIX A – Radiated Emission Below 1GHz Test Data 33**
- APPENDIX B – Radiated Emission Above 1GHz Test Data 35**
- APPENDIX C – AC Power Line Conducted Emission Test Data 45**

1. Test Report Declare

Applicant:	RAINVI TECHNOLOGIES PRIVATE LIMITED
Address:	8-2-283/82/A/321/1 HBS CO OP JUBILEE HILLS HYDERABAD, TELANGANA, INDIA - 500034
Manufacturer:	Guangzhou Yuandong Smart Sports Technology Co., LTD
Address:	Room 518, 192 Kezhu Road, Huangpu District, Guangzhou
Product Name:	Portl UltraGym 70
Brand Name:	NA
Model Name:	PUG-70
Difference Description:	NA

We Declare:

The equipment described above is tested by Guangzhou Jingce Testing Technology Co., Ltd. and in the configuration tested the equipment complied with the standards specified above. The test results are contained in this test report and Guangzhou Jingce Testing Technology Co., Ltd. is assumed of full responsibility for the accuracy and completeness of these tests except as provided information by clients.

2. Summary of Test Results

Summary of Test Results			
Clause	Test Items	FCC Rules	Test Results
1	6 dB Bandwidth	FCC Part 15.247 (a) (2)	Pass
2	Peak Conducted Output Power	FCC Part 15.247 (b) (3)	Pass
3	Power Spectral Density	FCC Part 15.247 (e)	Pass
4	Conducted Bandedge and Spurious Emission	FCC Part 15.247 (d)	Pass
5	Radiated Bandedge and Spurious Emission	FCC Part 15.247 (d) FCC Part 15.209 FCC Part 15.205	Pass
6	Conducted Emission Test For AC Power Port	FCC Part 15.207	Pass
7	Antenna Requirement	FCC Part 15.203	Pass

3. Test Laboratory

Guangzhou Jingce Testing Technology Co., Ltd.

Add.: No.10, Hefeng No.1 street, Huangpu District, Guangzhou, Guangdong, People's Republic of China

Association for Laboratory Accreditation(A2LA). Certificate Number: 6594.03

FCC Designation Number: CN1381. Test Firm Registration Number: 486550

IC Test Firm Registration Number: 31808

Conformity Assessment Body identifier: CN0173

4. Equipment Under Test

4.1. Description of EUT

EUT Name:	Portl UltraGym 70
Model Number:	PUG-70
EUT Function Description:	Please refer to user manual of this device
Power Supply:	AC 220V - 240V 50/60Hz 750W
Hardware Version:	NA
Software Version:	NA
Radio Specification:	Bluetooth V4.2
Operation Frequency:	2402 MHz - 2480 MHz
Modulation:	GFSK
Data Rate:	1Mbps
Antenna Type:	PC Antenna, MAX. Gain: 2.71 dBi

Note 1: EUT is the ab. of equipment under test.

Note 2: The antenna gain is declared by the customer and the laboratory is not responsible for the accuracy of the antenna gain.

4.2. Channel List

Channel	Frequency (MHz)	Channel	Frequency (MHz)	Channel	Frequency (MHz)	Channel	Frequency (MHz)
0	2402	11	2424	22	2446	33	2468
1	2404	12	2426	23	2448	34	2470
2	2406	13	2428	24	2450	35	2472
3	2408	14	2430	25	2452	36	2474
4	2410	15	2432	26	2454	37	2476
5	2412	16	2434	27	2456	38	2478
6	2414	17	2436	28	2458	39	2480
7	2416	18	2438	29	2460	/	/
8	2418	19	2440	30	2462	/	/
9	2420	20	2442	31	2464	/	/
10	2422	21	2444	32	2468	/	/

4.3. Test Channel Configuration

Tested mode, channel, information		
Mode	Channel	Frequency (MHz)
GFSK	LCH:CH0	2402
	MCH:CH19	2440
	HCH:CH39	2480

4.4. Test environment conditions

During the measurement the environmental conditions were within the listed ranges:

Temperature range:	21-25 °C
Humidity range:	40-75%
Pressure range:	86-106 kPa

4.5. The Worse Case Power Setting Parameter

The Worse Case Power Setting Parameter under 2400 ~ 2483.5MHz Band				
Test Software		EspRFTestTool_v2.8_Manual		
Modulation Type	Transmit Antenna Number	Test Software Setting Value		
		CH 00	CH 39	CH 78
GFSK	1	5	5	5

4.6. Description of Available Antennas

Test Mode	Transmit and Receive Mode	Description
GFSK	<input checked="" type="checkbox"/> 1TX, 1RX	Antenna 1 can be used as transmitting/receiving antenna.

5. Description of Test Setup

5.1. Accessory

Description of Accessories	Manufacturer	Model Number	Description	Remark
N/A	N/A	N/A	N/A	N/A

5.2. Support Equipment

Equipment	Brand Name	Model Name	P/N
PC	Lenovo	T480	/

5.3. Test Setup

The EUT can work in Fixed Frequency mode.

5.4. Setup Diagram for Tests



6. Measurement Uncertainty

Where relevant, the following measurement uncertainty levels have been estimated for tests performed on the apparatus:

Test Item	Uncertainty
AC Power Conduction emission	1.37 dB
All Radiated emissions	5.4dB
Conducted emissions	3.09 dB
Occupied Channel Bandwidth	1.1%
Conducted Output power	0.82dB
Power Spectral Density	0.82dB

Note: This uncertainty represents an expanded uncertainty expressed at approximately the 95 % confidence level using a coverage factor of $k = 2$.

7. Measuring Instrument and Software Used

TS Test System						
Used	Equipment	Manufacturer	Model No.	Serial No.	Last Cal.	Due. Date
<input checked="" type="checkbox"/>	Spectrum Analyzer	Keysight	N9030B	MY56320512	Sep. 12, 2023	Sep. 11, 2024
<input checked="" type="checkbox"/>	Vector Signal Generator	Keysight	N5182B	MY57300334	Sep. 12, 2023	Sep. 11, 2024
<input checked="" type="checkbox"/>	Signal Generator	Keysight	N5171B	MY57280639	Sep. 12, 2023	Sep. 11, 2024
<input checked="" type="checkbox"/>	DC POWER	Keysight	E342A	MY59020356	Jun. 29, 2024	Jun. 28, 2025
<input checked="" type="checkbox"/>	Incubator thermometer	GWS	EL-02JA	21107288	Sep. 12, 2023	Sep. 11, 2024
<input checked="" type="checkbox"/>	Control unit(Power sensor)	Tonscend	JS0806-2	/	Sep. 12, 2023	Sep. 11, 2024
<input checked="" type="checkbox"/>	Wideband radio communication tester	R&S	CMW500	163478	Jul. 03, 2024	Jul. 02, 2025
<input checked="" type="checkbox"/>	Spectrum Analyzer	Keysight	N9020B	MY60112206	Sep. 12, 2023	Sep. 12, 2024
<input checked="" type="checkbox"/>	Control unit(Power sensor)	Tonscend	JS0806-2	21H8060465	Sep. 12, 2023	Sep. 12, 2024
Software						
Used	Description	Manufacturer	Name		Version	
<input checked="" type="checkbox"/>	Test software	Tonscend	JS1120-3		V3.3.10	
RSE Test System						
Used	Equipment	Manufacturer	Model No.	Serial No.	Last Cal.	Due. Date
<input checked="" type="checkbox"/>	EMI Receiver	R&S	ESW	101685	Sep. 12, 2023	Sep. 11, 2024
<input checked="" type="checkbox"/>	Bilog Antenna	Schwarzbeck	VULB 9163	01416	May. 22, 2024	May. 21, 2025
<input checked="" type="checkbox"/>	Horn Antenna 1	Schwarzbeck	BBHA 9120 D	02910	Sep. 26, 2023	Sep. 25, 2024
<input checked="" type="checkbox"/>	Horn Antenna 2	ETS	BBHA 9170	1090	Sep. 04, 2023	Sep. 03, 2024
<input checked="" type="checkbox"/>	loop-antenna	Schwarzbeck	FMZB 1513-60	00030	Jan. 14, 2024	Jan. 13, 2025
<input checked="" type="checkbox"/>	Signal Pre-Amplifier	Tonscend	TAP01018050	AP23I8060293	Oct. 12, 2023	Oct. 11, 2024
<input checked="" type="checkbox"/>	Signal Pre-	ETS	3116C-PA	00217677	Sep. 02, 2024	Sep. 01, 2025

	Amplifier					
<input checked="" type="checkbox"/>	3m Fully-anechoic Chamber	YIHENG	9m*6m*6m	001	Sep. 05, 2023	Sep. 04, 2026
Software						
Used	Description	Manufacturer	Name		Version	
<input checked="" type="checkbox"/>	Test software	Tonscend	TS+		V3.0.0.4	
Conducted Emission Test For AC Power Port						
Used	Equipment	Manufacturer	Model No.	Serial No.	Last Cal.	Due. Date
<input checked="" type="checkbox"/>	LISN	R&S	ENV216	102509	Sep. 11, 2024	Sep. 10, 2025
<input checked="" type="checkbox"/>	EMI Receiver	R&S	ESR	102154	Sep. 11, 2024	Sep. 10, 2025
Software						
Used	Description	Manufacturer	Name		Version	
<input checked="" type="checkbox"/>	Test software	EZ	EZ-EMC		EMEC-3A1	
Other Instrument						
Used	Equipment	Manufacturer	Model No.	Serial No.	Last Cal.	Due. Date
<input checked="" type="checkbox"/>	Temperature & Humidity	Temperature	HTC-1	/	Nov. 02, 2023	Nov. 01, 2024

8. On Time and Duty Cycle

8.1. Block diagram of test setup

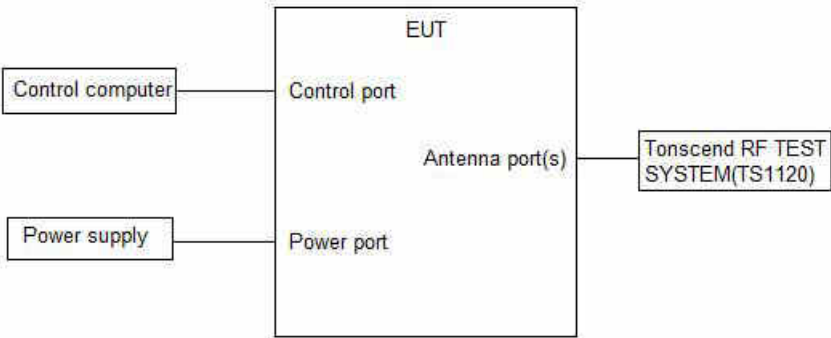

8.2. Limits

None; for reporting purposes only

8.3. Procedure

KDB 558074 Zero-Span Spectrum Analyzer Method

8.4. Results

Test Mode	Ant.	Freq. (MHz)	ON Time (ms)	Period (ms)	Duty Cycle (%)	Duty Cycle Factor(dB)
BLE_1M	Ant1	2402	2.09	2.50	83.60	0.78
		2440	2.10	2.50	84.00	0.76
		2480	2.09	2.50	83.60	0.78

Note: Duty Cycle Correction Factor = $10\log(1/x)$.
 Where: x is Duty Cycle(Linear)
 Where: T is On Time (transmit duration)
 If that calculated VBW is not available on the analyzer, then the next higher value should be used.

8.5. Original test data

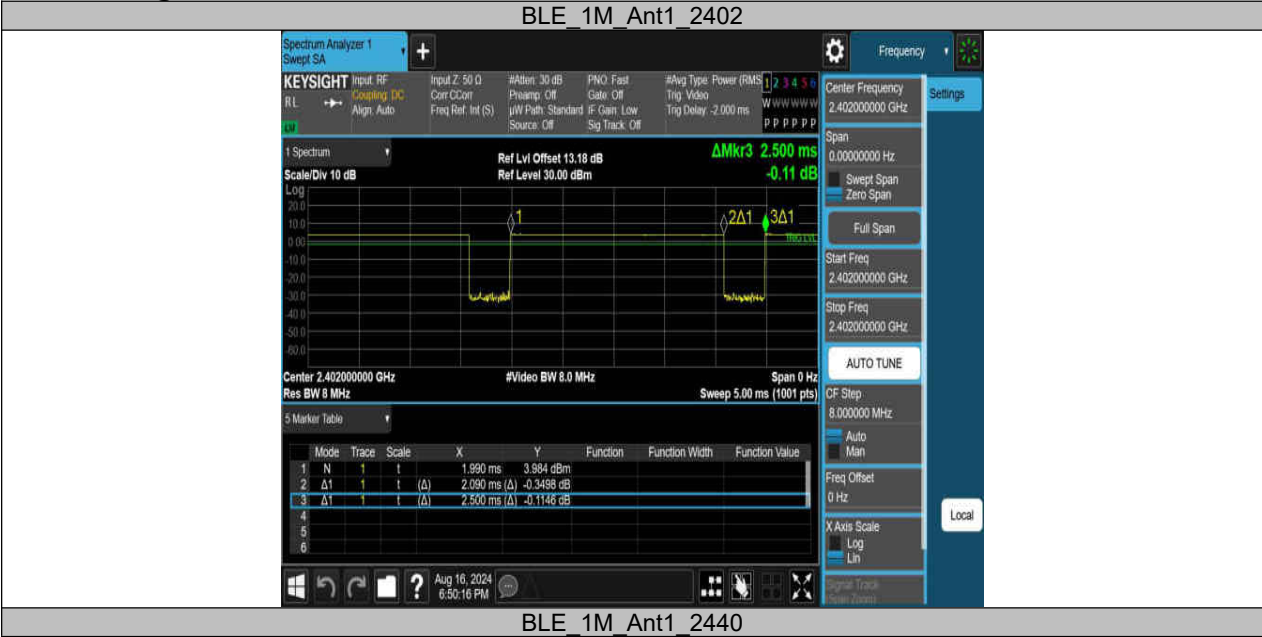



BLE 1M Ant1 2480



9. 6 dB DTS Bandwidth

9.1. Block diagram of test setup

Same as section 8.1

9.2. Limits

CFR 47FCC Part15 (15.247) Subpart C			
Section	Test Item	Limit	Frequency Range (MHz)
CFR 47 FCC 15.247(a)(2)	6 dB Bandwidth	≥ 500 kHz	2400-2483.5

9.3. Test Procedure

Connect the UUT to the spectrum analyzer and use the following settings:

Center Frequency	The center frequency of the channel under test
Detector	Peak
RBW	For 6 dB Bandwidth :100 kHz For 99 % Occupied Bandwidth :1 % to 5 % of the occupied bandwidth
VBW	For 6 dB Bandwidth : $\geq 3 \times$ RBW For 99 % Occupied Bandwidth : $\geq 3 \times$ RBW
Trace	Max hold
Sweep	Auto couple

Allow the trace to stabilize and measure the maximum width of the emission that is constrained by the frequencies associated with the two outermost amplitude points (upper and lower frequencies) that are attenuated by 6 dB/99 % relative to the maximum level measured in the fundamental emission.

9.4. Results

Test Mode	Ant.	Freq. (MHz)	DTS BW (MHz)	FL (MHz)	FH (MHz)	Limit (MHz)	Verdict
BLE_1M	Ant1	2402	0.636	2401.648	2402.284	0.5	PASS
		2440	0.628	2439.652	2440.280	0.5	PASS
		2480	0.648	2479.640	2480.288	0.5	PASS

Test Mode	Antenna	Frequency (MHz)	OCB (MHz)	FL(MHz)	FH(MHz)	Limit(MHz)	Verdict
BLE_1M	Ant1	2402	1.0261	2401.4503	2402.4764	---	---
		2440	1.0294	2439.4486	2440.4780	---	---
		2480	1.0130	2479.4595	2480.4725	---	---

9.5. Original test data

6 dB bandwidth:



99% bandwidth



10. Peak Conducted Output Power

10.1. Block diagram of test setup

Same as section 8.1

10.2. Limits

CFR 47 FCC Part15 (15.247) Subpart C			
Section	Test Item	Limit	Frequency Range (MHz)
CFR 47 FCC 15.247(b)(3)	Peak Output Power	1 watt or 30 dBm	2400 - 2483.5

10.3. Test Procedure

Connect EUT's antenna output to spectrum analyzer by RF cable.

99% Bandwidth set the spectrum analyzer as follows:

RBW:	30 kHz
VBW:	100 kHz
Detector Mode:	Peak
Sweep time:	auto
Trace mode	Max hold

6 dB Bandwidth set the spectrum analyzer as follows:

RBW:	100 kHz
VBW:	300 kHz
Detector Mode:	Peak
Sweep time:	auto
Trace mode	Max hold

Allow the trace to stabilize, measure the 6 dB and 99% bandwidth of signal.

10.4. Results

Test Mode	Ant.	Freq (MHz)	Conducted Peak Power (dBm)	Conducted Limit (dBm)	Verdict
BLE_1M	Ant1	2402	3.97	≤30	PASS
		2440	3.66	≤30	PASS
		2480	3.13	≤30	PASS

10.5. Original test data

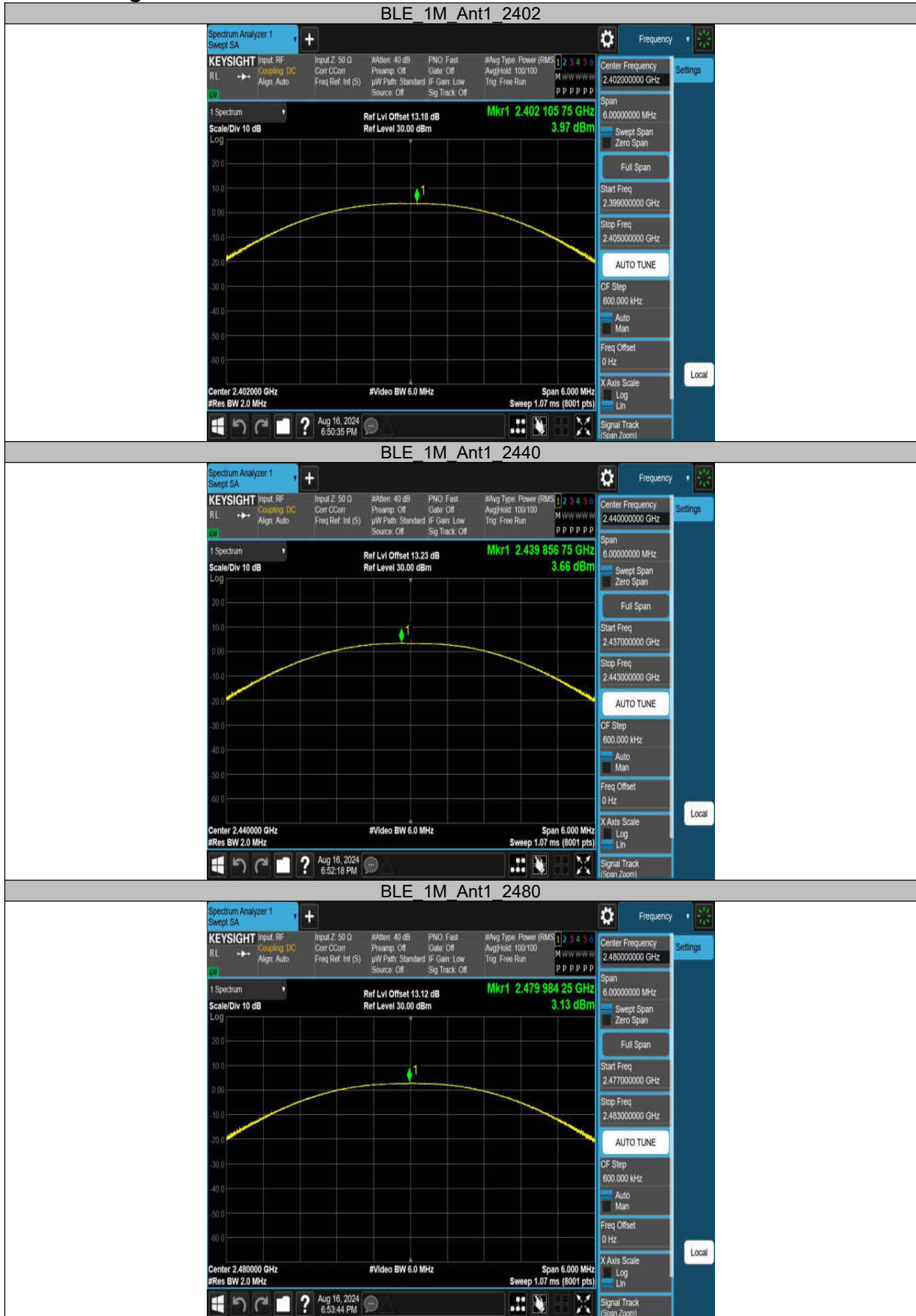

11. Power Spectral Density

11.1. Block diagram of test setup

Same as section 8.1

11.2. Limits

CFR 47 FCC Part15 (15.247) Subpart C			
Section	Test Item	Limit	Frequency Range (MHz)
CFR 47 FCC §15.247 (e)	Power Spectral Density	8 dBm in any 3 kHz band	2400 - 2483.5

11.3. Test Procedure

Connect the UUT to the spectrum analyzer and use the following settings:

Center Frequency	The center frequency of the channel under test
Detector	Peak
RBW	$3 \text{ kHz} \leq \text{RBW} \leq 100 \text{ kHz}$
VBW	$\geq 3 \times \text{RBW}$
Span	1.5 x DTS bandwidth
Trace	Max hold
Sweep time	Auto couple.

Allow trace to fully stabilize and use the peak marker function to determine the maximum amplitude level within the RBW.

If measured value exceeds limit, reduce RBW (no less than 3 kHz) and repeat.

11.4. Results

Test Mode	Ant.	Freq. (MHz)	Result (dBm/3kHz)	Limit (dBm/3kHz)	Verdict
BLE_1M	Ant1	2402	-12.59	≤ 8.00	PASS
		2440	-12.81	≤ 8.00	PASS
		2480	-13.73	≤ 8.00	PASS

11.5. Original test data

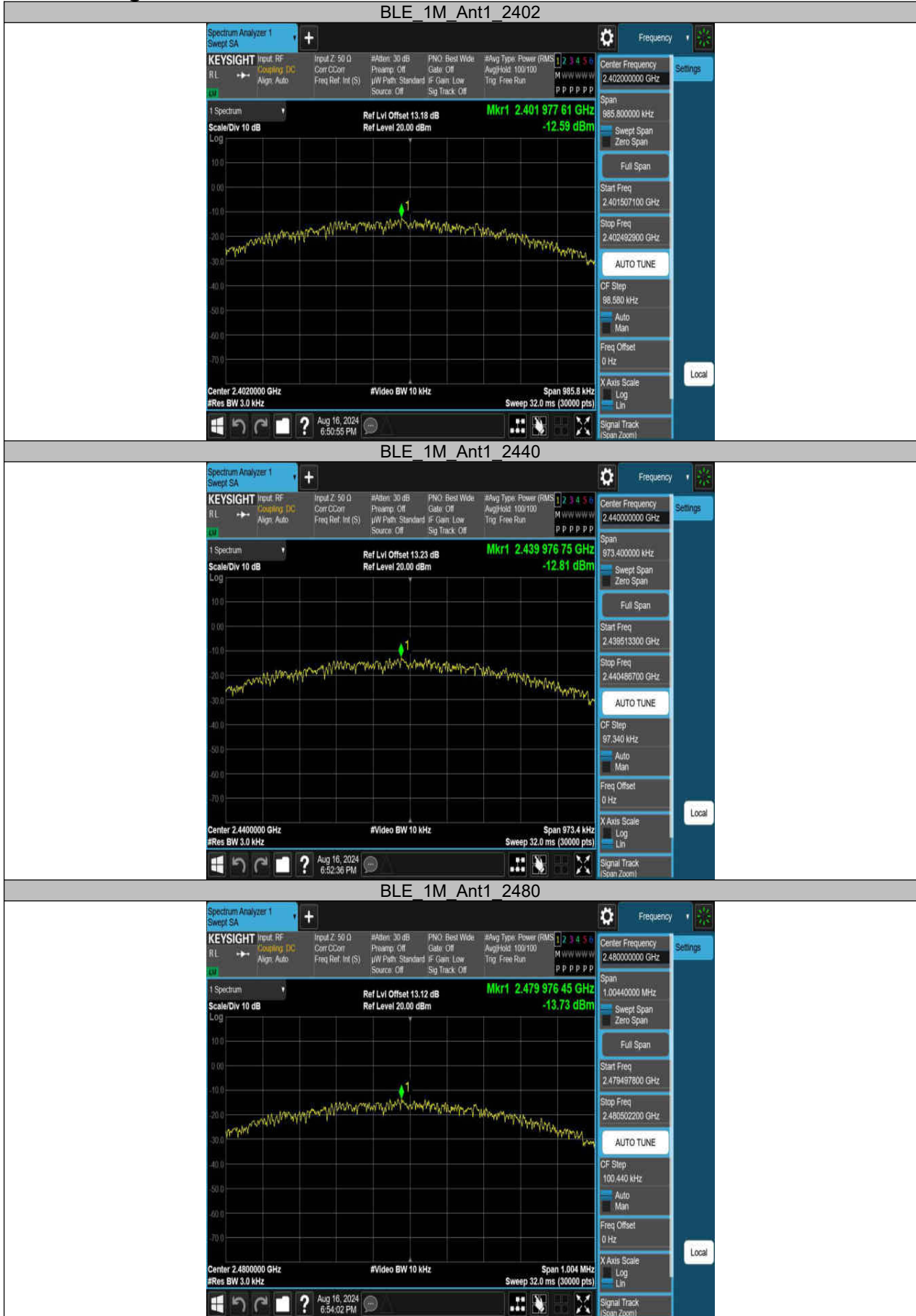

12. Conducted Bandedge and Spurious Emissions

12.1. Block diagram of test setup

Same as section 8.1

12.2. Limits

CFR 47 FCC Part15 (15.247) Subpart C		
Section	Test Item	Limit
CFR 47 FCC §15.247 (d)	Conducted Band edge and Spurious Emissions	at least 20 dB below that in the 100 kHz bandwidth within the band that contains the highest level of the desired power

12.3. Test Procedure

Center Frequency	The center frequency of the channel under test
Detector	Peak
RBW	100 kHz
VBW	$\geq 3 \times \text{RBW}$
Span	$\geq 1.5 \times \text{DTS bandwidth}$
Trace	Max hold
Sweep time	Auto couple

Connect the UUT to the spectrum analyzer and use the following settings:

Use the peak marker function to determine the maximum peak power level to establish the reference level.

Span	Set the center frequency and span to encompass frequency range to be measured
Detector	Peak
RBW	100 kHz
VBW	$\geq 3 \times \text{RBW}$
measurement points	$\geq \text{span/RBW}$
Trace	Max hold
Sweep time	Auto couple

Use the peak marker function to determine the maximum amplitude level.

12.4. Results

Band edge

Test Mode	Antenna	Ch Name	Frequency (MHz)	Ref Level(dBm)	Result(dBm)	Limit(dBm)	Verdict
BLE_1M	Ant1	Low	2402	3.38	-48.23	≤ -16.62	PASS
		High	2480	2.76	-47.68	≤ -17.24	PASS

Spurious Emissions

Test Mode	Antenna	Frequency (MHz)	Freq Range (MHz)	Ref Level (dBm)	Result(dBm)	Limit(dBm)	Verdict
BLE_1M	Ant1	2402	Reference	3.76	3.76	---	PASS
			30~1000	3.76	-48.88	≤ -16.24	PASS
			1000~26500	2.55	-34.15	≤ -17.45	PASS
		2480	Reference	2.81	2.81	---	PASS
			30~1000	2.81	-48.13	≤ -17.19	PASS
			1000~26500	2.81	-38.7	≤ -17.19	PASS

12.5. Original test data

Band edge:



Spurious Emissions:

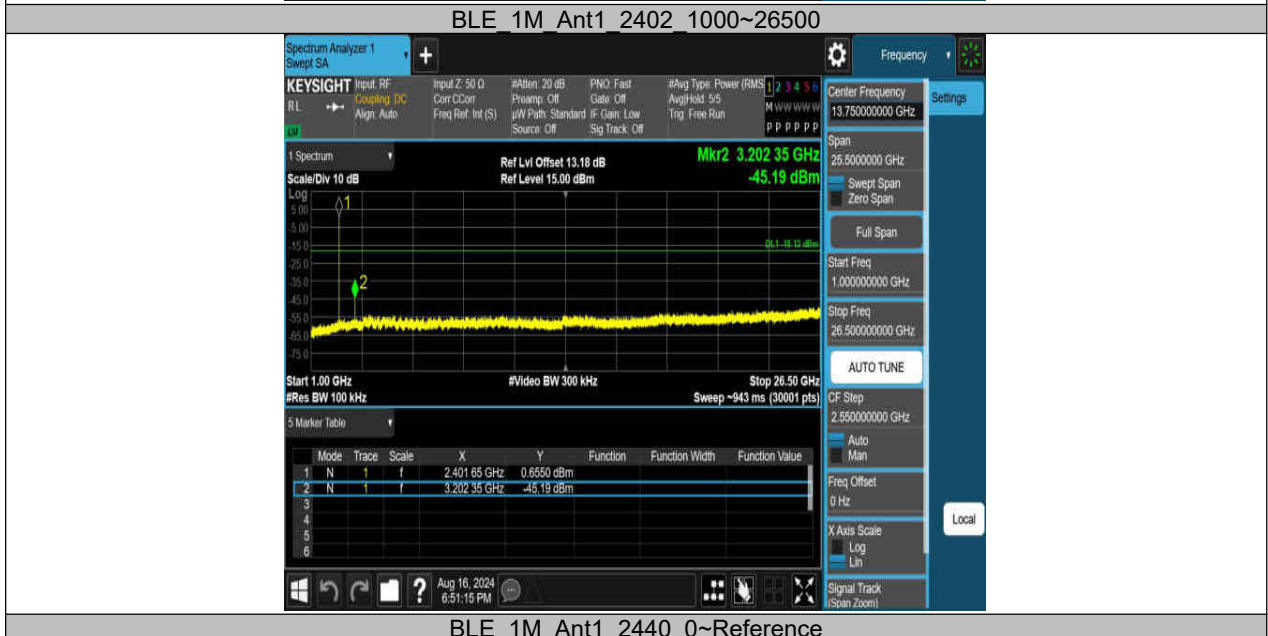
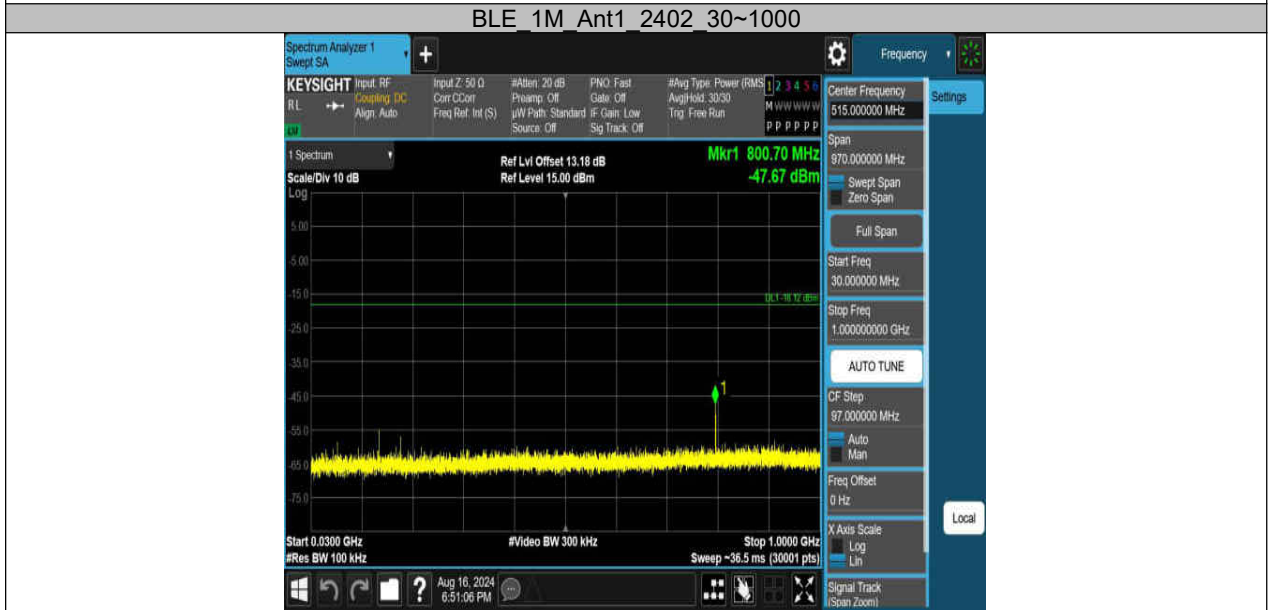

BLE 1M Ant1 2440 0~Reference

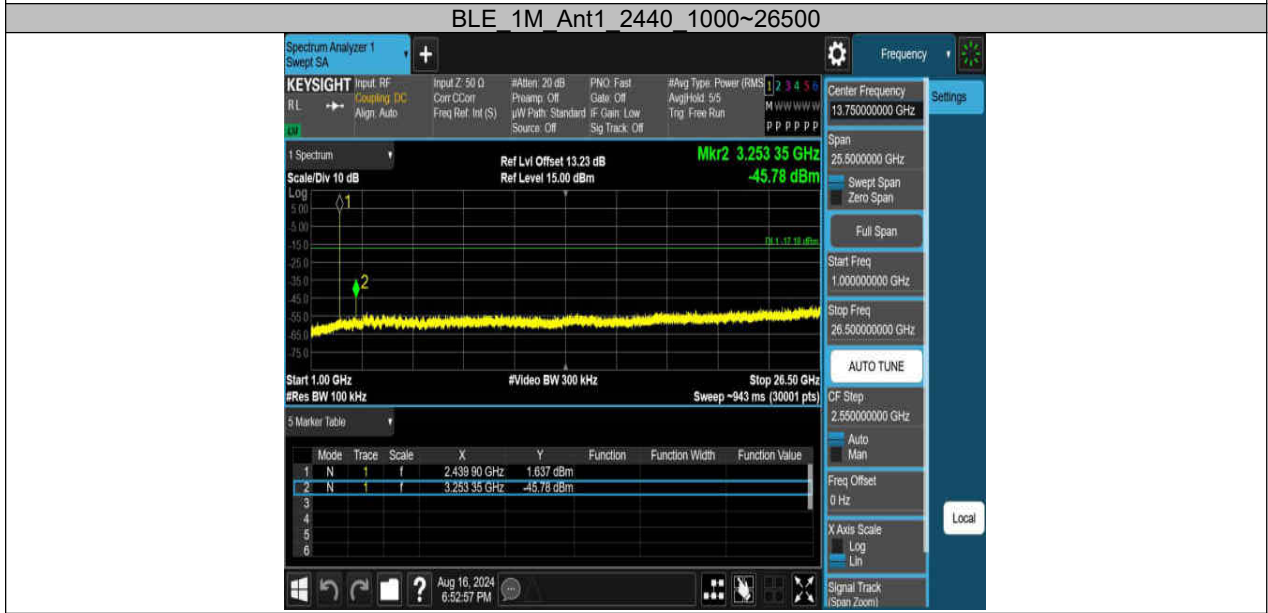
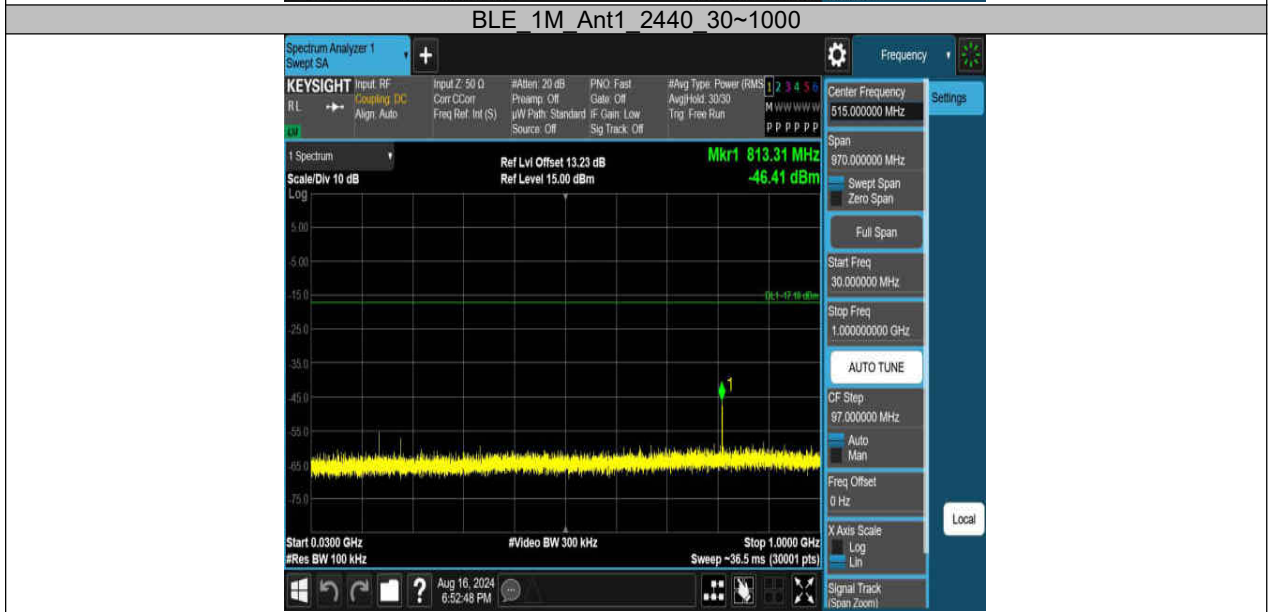

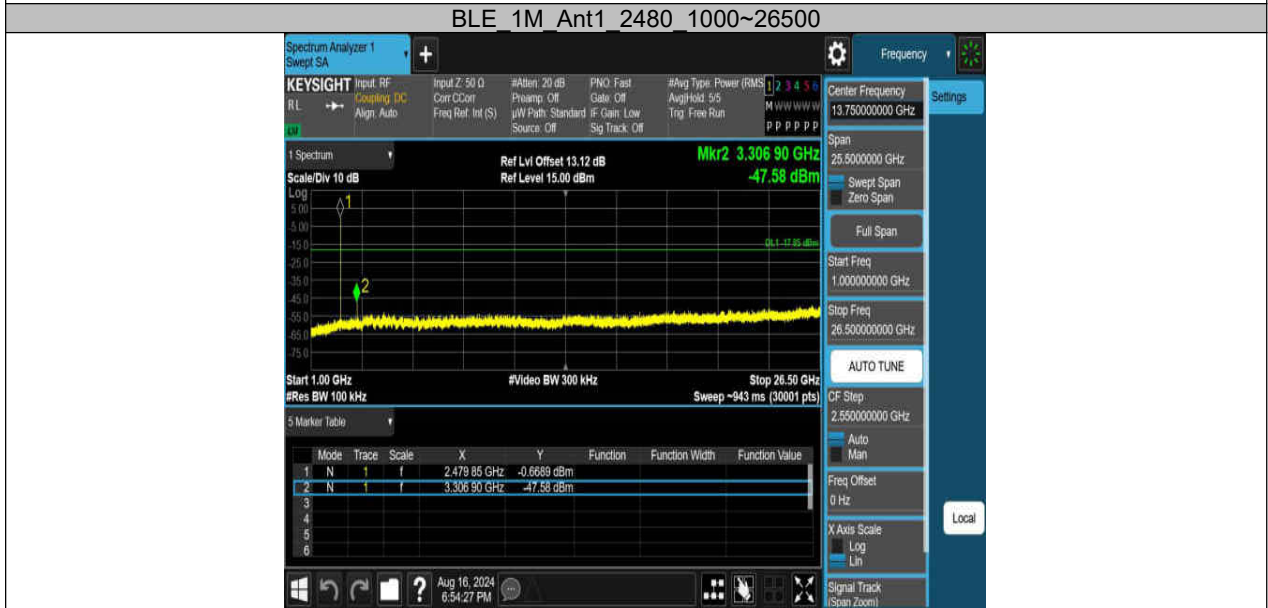
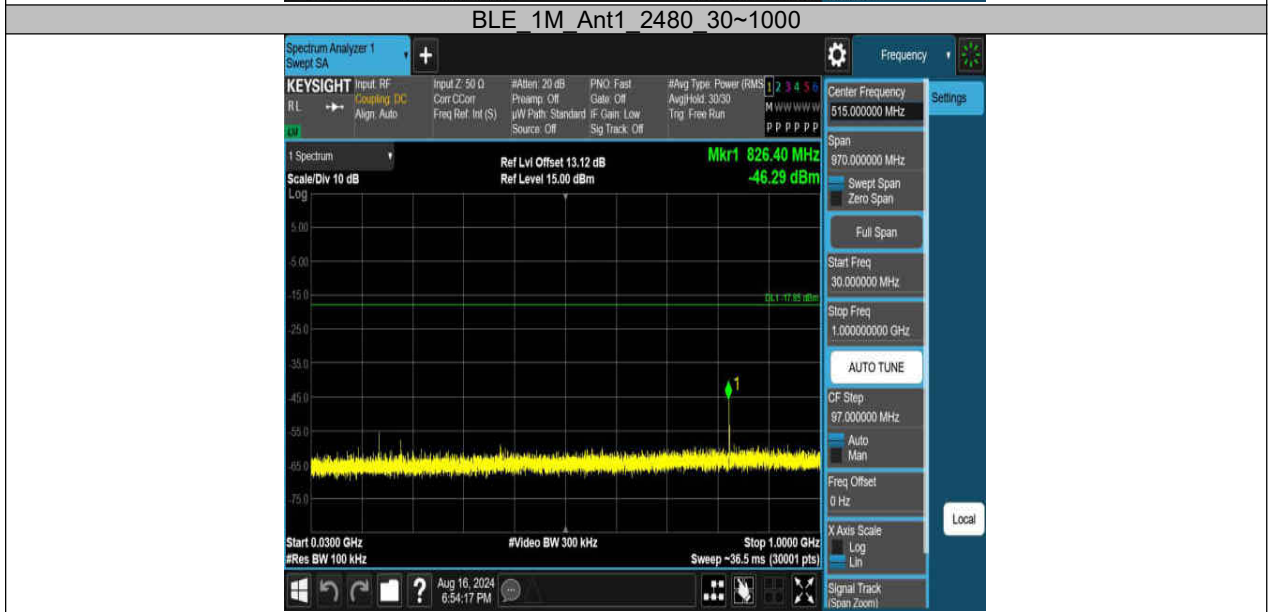

13. Radiated Emission

13.1. Block diagram of test setup

In 3 m Anechoic Chamber, test setup diagram for 9 kHz - 30 MHz:

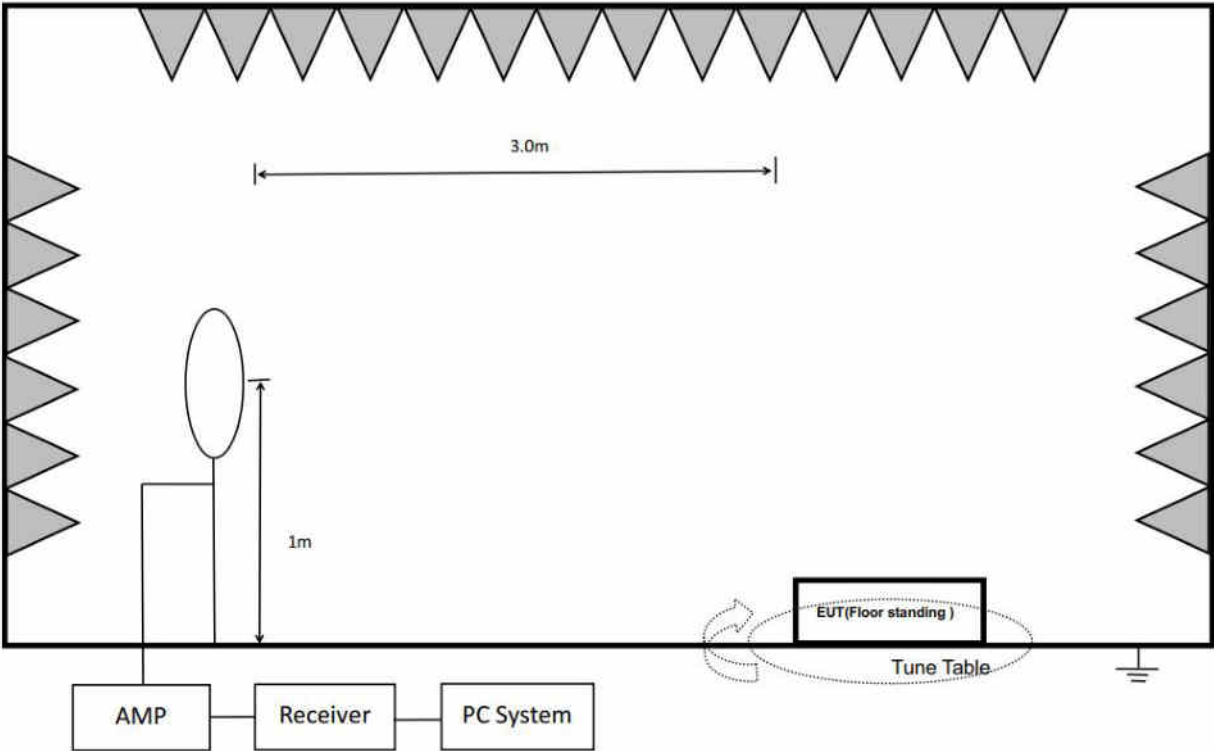

In 3 m Anechoic Chamber, test setup diagram for 30 MHz - 1 GHz:

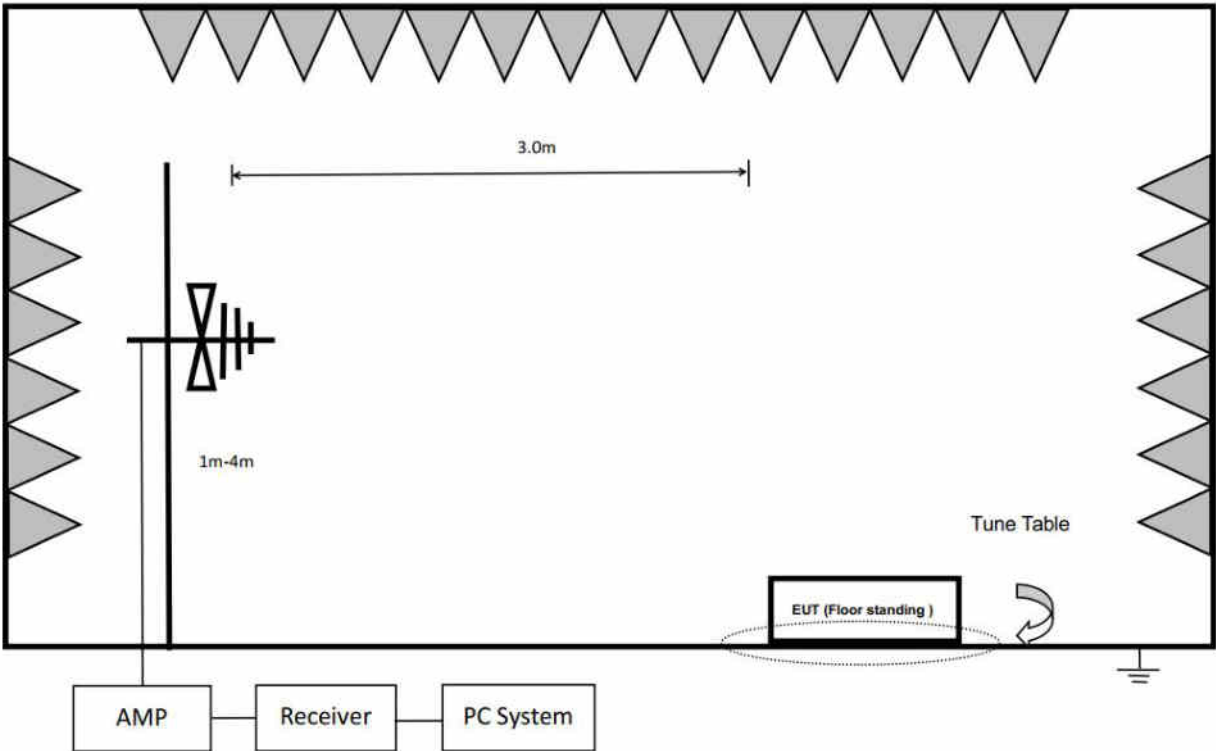

In 3 m Anechoic Chamber, test setup diagram for frequency above 1 GHz:

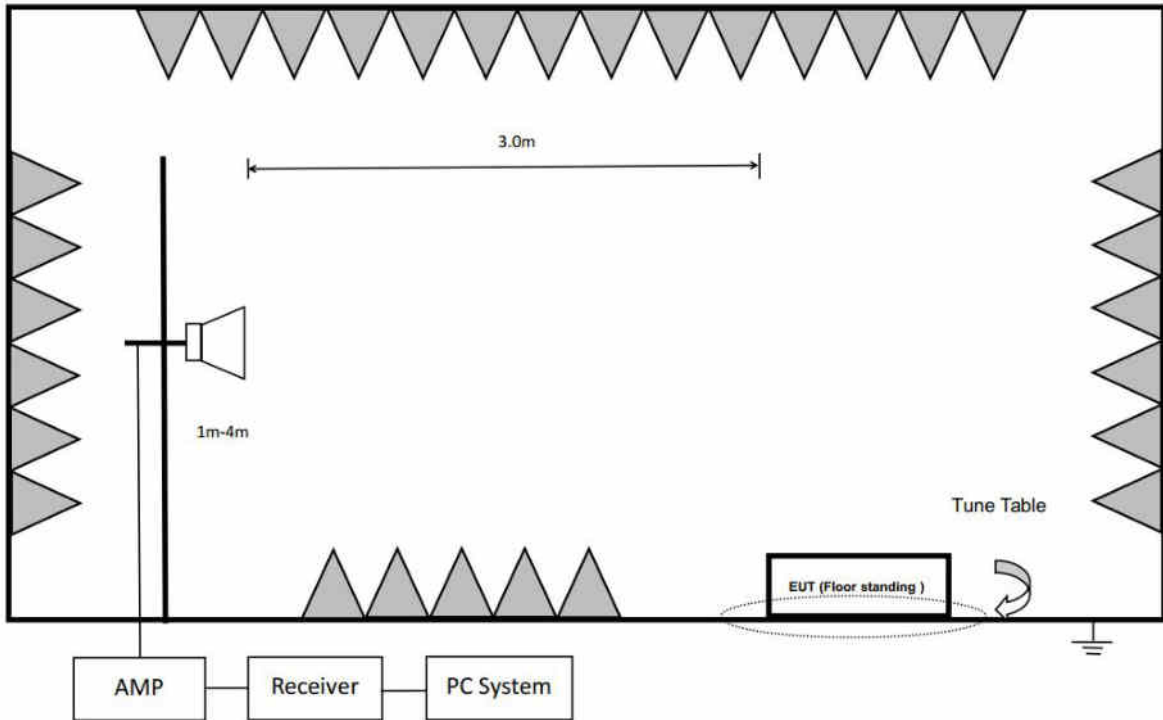

Note: For harmonic emissions test an appropriate high pass filter was inserted in the input port of AMP.

13.2. Limit

(1) FCC 15.205 Restricted frequency band

MHz	MHz	MHz	GHz
0.090-0.110	16.42-16.423	399.9-410	4.5-5.15
¹ 0.495-0.505	16.69475-16.69525	608-614	5.35-5.46
2.1735-2.1905	16.80425-16.80475	960-1240	7.25-7.75
4.125-4.128	25.5-25.67	1300-1427	8.025-8.5
4.1772&4.17775	37.5-38.25	1435-1626.5	9.0-9.2
4.2072&4.20775	73-74.6	1645.5-1646.5	9.3-9.5
6.215-6.218	74.8-75.2	1660-1710	10.6-12.7
6.26775-6.26825	108-121.94	1718.8-1722.2	13.25-13.4
6.31175-6.31225	123-138	2200-2300	14.47-14.5
8.291-8.294	149.9-150.05	2310-2390	15.35-16.2
8.362-8.366	156.52475-156.52525	2483.5-2500	17.7-21.4
8.37625-8.38675	156.7-156.9	2690-2900	22.01-23.12
8.41425-8.41475	162.0125-167.17	3260-3267	23.6-24.0
12.29-12.293	167.72-173.2	3332-3339	31.2-31.8
12.51975-12.52025	240-285	3345.8-3358	36.43-36.5
12.57675-12.57725	322-335.4	3600-4400	(²)
13.36-13.41			

¹Until February 1, 1999, this restricted band shall be 0.490-0.510 MHz.

²Above 38.6

(2) FCC 15.209 Limit.

Frequency MHz	Distance Meters	Field Strengths Limit	
		$\mu\text{V}/\text{m}$	$\text{dB}(\mu\text{V})/\text{m}$
0.009 ~ 0.490	300	2400/F(kHz)	67.6-20log(F)
0.490 ~ 1.705	30	24000/F(kHz)	87.6-20log(F)
1.705 ~ 30.0	30	30	29.54
30 ~ 88	3	100	40.0
88 ~ 216	3	150	43.5
216~960	3	200	46.0
960~1000	3	500	54.0
Above 1000	3	74.0 $\text{dB}(\mu\text{V})/\text{m}$ (Peak) 54.0 $\text{dB}(\mu\text{V})/\text{m}$ (Average)	

Note: (1) At frequencies at or above 30 MHz, measurements may be performed at a distance other than what is specified provided: measurements are not made in the near field except where it can be shown that near field measurements are appropriate due to the characteristics of the device; and it can be demonstrated that the signal levels needed to be measured at the distance employed can be detected by the measurement equipment. Measurements shall not be performed at a distance greater than 30 meters unless it can be further demonstrated that measurements at a distance of 30 meters or less are impractical. When performing measurements at a distance other than that specified, the results shall be extrapolated to the specified distance using an extrapolation factor of 20 dB/decade (inverse linear-distance for field strength measurements; inverse-linear-distance-squared for power density measurements).

(2) At frequencies below 30 MHz, measurements may be performed at a distance closer than that specified in the regulations; however, an attempt should be made to avoid making measurements in the near field. Pending the development of an appropriate measurement procedure for measurements performed below 30 MHz, when performing measurements at a closer distance than specified, the results shall be extrapolated to the specified distance by either making measurements at a minimum of two distances on at least one radial to determine the proper extrapolation factor or by using the square of an inverse linear distance extrapolation factor (40 dB/decade). This paragraph (f) shall not apply to Access BPL devices operating below 30 MHz.

About Restricted bands of operation please refer to FCC § 15.205(a),

13.3. Test Procedure

Below 30 MHz:

The setting of the spectrum Analyzer

RBW	300 Hz (From 9 kHz to 0.15 MHz)/ 10 kHz (From 0.15 MHz to 30 MHz)
VBW	1 kHz (From 9 kHz to 0.15 MHz)/ 30 kHz (From 0.15 MHz to 30 MHz)
Sweep	Auto
Trace	Max hold

1. The testing follows the guidelines in ANSI C63.10-2013

2. The EUT was arranged to its worst case and then turntable (from 0 degree to 360 degrees) to find the maximum reading. A pre-amp and a high pass filter are used for the test in order to get better signal level. Both Horizontal, Face-on and Face-off polarizations of the antenna are set to make the measurement.

3. The EUT and all cables shall be insulated, if required, from the ground plane by up to 12mm of insulating material.

4. The EUT was set 3 meters from the interference receiving antenna, which was mounted on the top of 1 meter height antenna tower.

5. The radiated emission limits are based on measurements employing a CISPR quasi-peak detector except for the frequency bands 9-90 kHz, 110-490 kHz and above 1000 MHz. Radiated emission limits in these three bands are based on measurements employing an average detector.

6. For measurement below 1 GHz, the initial step in collecting conducted emission data is a spectrum analyzer peak detector mode pre-scanning the measurement frequency range. Significant peaks are

then marked and then Quasi Peak detector mode re-measured. If the emission level of the EUT measured by the peak detector is 3 dB lower than the applicable limit, the peak emission level will be reported. Otherwise, the emission measurement will be repeated using the quasi-peak detector and reported.

7. Although these tests were performed other than open field site, adequate comparison measurements were confirmed against 30m open field site. Therefore, sufficient tests were made to demonstrate that the alternative site produces results that correlate with the ones of tests made in an open field site based on KDB 414788.

Below 1 GHz and above 30 MHz:

The setting of the spectrum Analyzer

RBW	100 kHz
VBW	300 kHz
Sweep	Auto
Trace	Max hold

1. The testing follows the guidelines in ANSI C63.10-2013.

2. The EUT was arranged to its worst case and then tune the antenna tower (from 1 m to 4 m) and turntable (from 0 degree to 360 degrees) to find the maximum reading. A pre-amp and a high pass filter are used for the test in order to get better signal level. Both horizontal and vertical polarizations of the antenna are set to make the measurement.

3. The EUT and all cables shall be insulated, if required, from the ground plane by up to 12mm of insulating material.

4. The EUT was set 3 meters from the interference receiving antenna, which was mounted on the top of a variable height antenna tower.

5. For measurement below 1GHz, the initial step in collecting conducted emission data is a spectrum analyzer peak detector mode pre-scanning the measurement frequency range. Significant peaks are then marked and then Quasi Peak detector mode re-measured. If the emission level of the EUT measured by the peak detector is 3 dB lower than the applicable limit, the peak emission level will be reported. Otherwise, the emission measurement will be repeated using the quasi-peak detector and reported.

Above 1 GHz:

RBW	1 MHz
VBW	PEAK: 3 MHz AVG: see note 6
Sweep	Auto
Detector	Peak
Trace	Max hold

1. The testing follows the guidelines in ANSI C63.10-2013.

2. The EUT was arranged to its worst case and then tune the antenna tower (from 1 m to 4 m) and turntable (from 0 degree to 360 degrees) to find the maximum reading. A pre-amp and a high pass filter are used for the test in order to get better signal level. Both horizontal and vertical polarizations of the antenna are set to make the measurement.

3. The EUT and all cables shall be insulated, if required, from the ground plane by up to 12mm of insulating material.

4. The EUT was set 3 meters from the interference receiving antenna, which was mounted on the top of a variable height antenna tower.

5. For measurement above 1GHz, the emission measurement will be measured by the peak detector. This peak level, once corrected, must comply with the limit specified in Section 15.209.

6. For measurements above 1 GHz the resolution bandwidth is set to 1 MHz, then the video bandwidth is set to 3 MHz for peak measurements and 1 MHz resolution bandwidth with 1/T video bandwidth with peak detector for AVG measurements. For the Duty Cycle please refer to clause 8.1.ON TIME AND DUTY CYCLE.

7. Restriction band: Investigated frequency range from 2310 MHz to 2410 MHz and 2470MHz to 2500 MHz.

All restriction band should comply with 15.209, other emission should be at least 20 dB below the fundamental.

Note 1: For all radiated test, EUT in each of three orthogonal axis emissions had been tested, but only the worst case (X axis) data recorded in the report.

Note 2: The EUT does not support simultaneous transmission.

Note 3: The EUT was fully exercised with external accessories during the test. In the case of multiple accessory external ports, an external accessory shall be connected to one of each type of port.

13.4. Results

Pass. (See below detailed test result)

All the emissions except fundamental emission from 9 kHz to 25 GHz were comply with 15.209 limits.

Note1: According exploratory test, the emission levels are 20 dB below the limit detected from 9 kHz to 30 MHz, so the final test was performed with frequency range from 30 MHz to 26 GHz and recorded in below.

Note2: For emissions below 1 GHz, according exploratory explorer test, when change Tx mode and channel, have no distinct influence on emissions level, so for emissions below 1 GHz, the final test was only performed with EUT working in Tx BLE 2402 MHz mode.

Note3: For emissions above 1 GHz. If peak results comply with AV limit, AV Result is deemed to comply with AV limit.

13.5. Original test data

Below 1 GHz and above 30 MHz test data Refer to appendix A

Above 1 GHz test data Refer to appendix B

14. AC Power Line Conducted Emissions

14.1. Block diagram of test setup

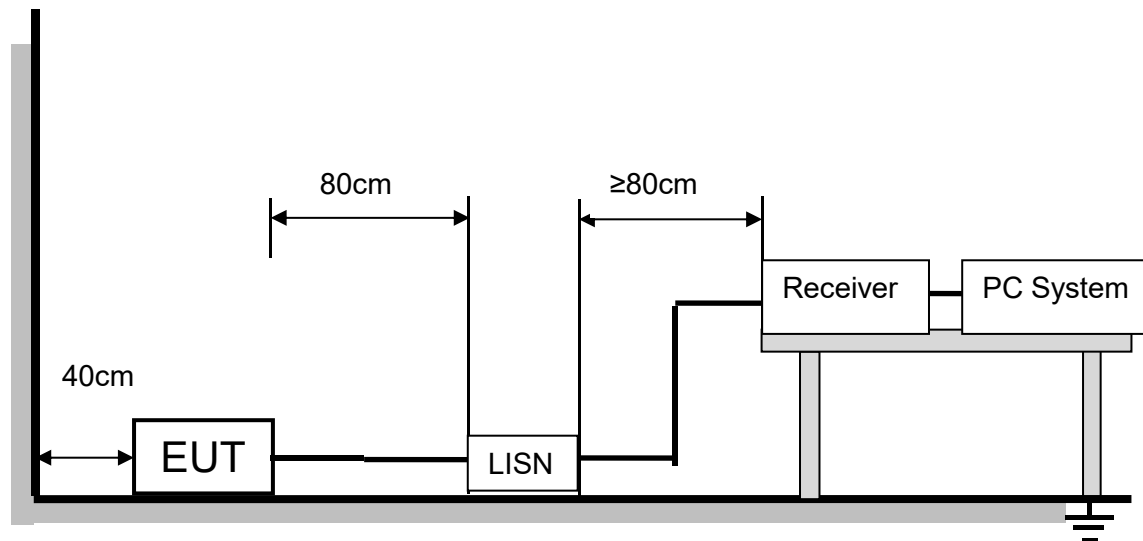

The EUT and all cables shall be insulated, if required, from the ground plane by up to 12mm of insulating material. The vertical conducting wall of shielding is located 40 cm to the rear of the EUT. The power line of the EUT is connected to the AC mains through an Artificial Mains Network (A.M.N.). A EMI Measurement Receiver (R&S Test Receiver ESR3) is used to test the emissions from both sides of AC line. According to the requirements in Section 6.2 of ANSI C63.10-2013. Conducted emissions from the EUT measured in the frequency range between 0.15 MHz and 30 MHz using CISPR Quasi-Peak and average detector mode. The bandwidth of EMI test receiver is set at 9 kHz.

The arrangement of the equipment is installed to meet the standards and operating in a manner, which tends to maximize its emission characteristics in a normal application.

14.2. Limits

Please refer to CFR 47 FCC § 15.207 (a).

Frequency (MHz)	Quasi-peak	Average
0.15 -0.5	66 - 56 *	56 - 46 *
0.50 -5.0	56.00	46.00
5.0 -30.0	60.00	50.00

Note 1: * Decreasing linearly with logarithm of frequency.

Note 2: The lower limit shall apply at the transition frequencies.

14.3. Test procedure

The EUT and Support equipment, if needed, were put placed on a insulating material, 12mm above the ground plane.

Configuration EUT to simulate typical usage as described in clause 2.4 and test equipment as described in clause 10.2 of this report.

All I/O cables were positioned to simulate typical actual usage as per ANSI C63.10.

All support equipment power received from a second LISN.

Emissions were measured on each current carrying line of the EUT using an EMI Test Receiver connected to the LISN powering the EUT.

The Receiver scanned from 150 kHz to 30 MHz for emissions in each of the test modes.

During the above scans, the emissions were maximized by cable manipulation.

The test mode(s) described in clause 2.4 were scanned during the preliminary test.

After the preliminary scan, we found the test mode producing the highest emission level.

The EUT configuration and worse cable configuration of the above highest emission levels were recorded for reference of the final test.

EUT and support equipment were set up on the test bench as per the configuration with highest emission level in the preliminary test.

A scan was taken on both power lines, Neutral and Line, recording at least the six highest emissions.

Emission frequency and amplitude were recorded into a computer in which correction factors were used to calculate the emission level and compare reading to the applicable limit.

The test data of the worst-case condition(s) was recorded.

The bandwidth of test receiver is set at 9 kHz.

14.4. Test result

Pass. (See below detailed test result)

Note1: All emissions not reported below are too low against the prescribed limits.

14.5. Original test data

AC Power Line Conducted Emission Test Data Refer to appendix C

15. Antenna Requirements

15.1. Limits

Please refer to FCC § 15.203

An intentional radiator shall be designed to ensure that no antenna other than that furnished by the responsible party shall be used with the device. The use of a permanently attached antenna or of an antenna that uses a unique coupling to the intentional radiator shall be considered sufficient to comply with the provisions of this section. The manufacturer may design the unit so that a broken antenna can be replaced by the user, but the use of a standard antenna jack or electrical connector is prohibited.

Please refer to FCC § 15.247(b)(4)

The conducted output power limit specified in paragraph (b) of this section is based on the use of antennas with directional gains that do not exceed 6 dBi. Except as shown in paragraph (c) of this section, if transmitting antennas of directional gain greater than 6 dBi are used, the conducted output power from the intentional radiator shall be reduced below the stated values in paragraphs (b)(1), (b)(2), and (b)(3) of this section, as appropriate, by the amount in dB that the directional gain of the antenna exceeds 6 dBi.

15.2. Result

The antenna used for this product is FPC antenna and that no antenna other than that furnished by the responsible party shall be used with the device, the maximum peak gain of the transmit antenna is 2.71 dBi

APPENDIX A – Radiated Emission Below 1GHz Test Data Test Report

Project Information			
Customer:			
EUT:	Portl UltraGym 70		
Model:	PUG-70	SN:	
Mode:	BLE_1M_2402	Voltage:	AC220V/60Hz
Environment:	Temp: 25°C; Humi:60%	Engineer:	Soho Liu
Remark:			
Test Standard: FCC PART 15 C			

Start of Test: 2024-08-20 18:25:46

Test Graph

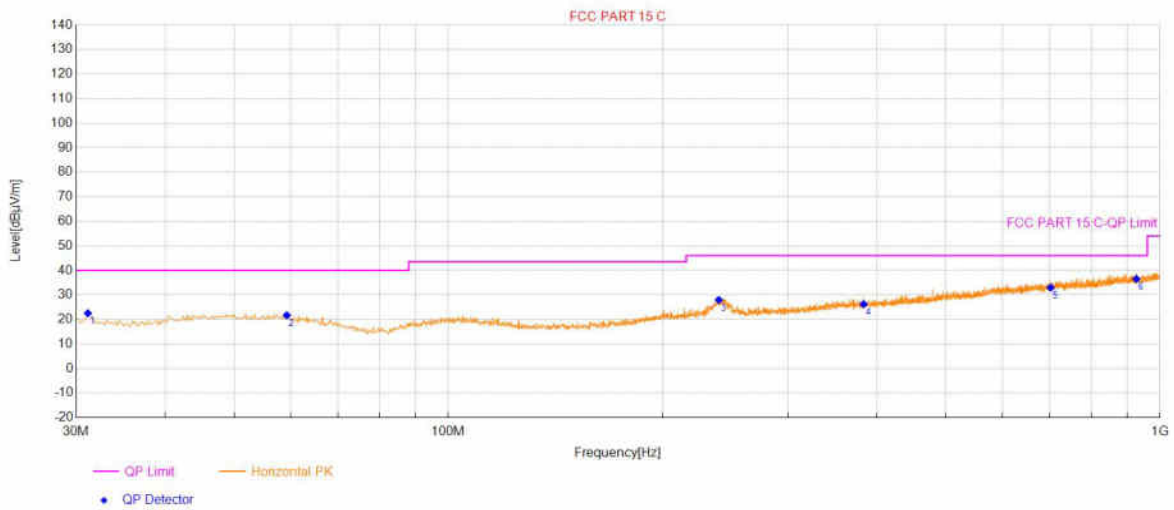

Final Data List									
NO.	Frequency (MHz)	Factor (dB/m)	QP Value (dBµV/m)	QP Limit (dBµV/m)	QP Margin (dB)	Height (cm)	Angle (°)	Polarity	Verdict
1	31.1642	17.72	22.55	40.00	17.45	100	111	Horizontal	PASS
2	59.2999	20.38	21.70	40.00	18.30	100	322	Horizontal	PASS
3	239.9500	21.67	27.96	46.00	18.04	100	360	Horizontal	PASS
4	383.3447	25.49	26.24	46.00	19.76	100	305	Horizontal	PASS
5	701.9564	31.27	32.99	46.00	13.01	100	207	Horizontal	PASS
6	926.2653	34.81	36.51	46.00	9.49	100	360	Horizontal	PASS

Test Report

Project Information			
Customer:			
EUT:	Portl UltraGym 70		
Model:	PUG-70	SN:	
Mode:	BLE_1M_2402	Voltage:	AC220V/60Hz
Environment:	Temp: 25°C; Humi:60%	Engineer:	Soho Liu
Remark:			
Test Standard: FCC PART 15 C			

Start of Test: 2024-08-20 18:26:32

Test Graph

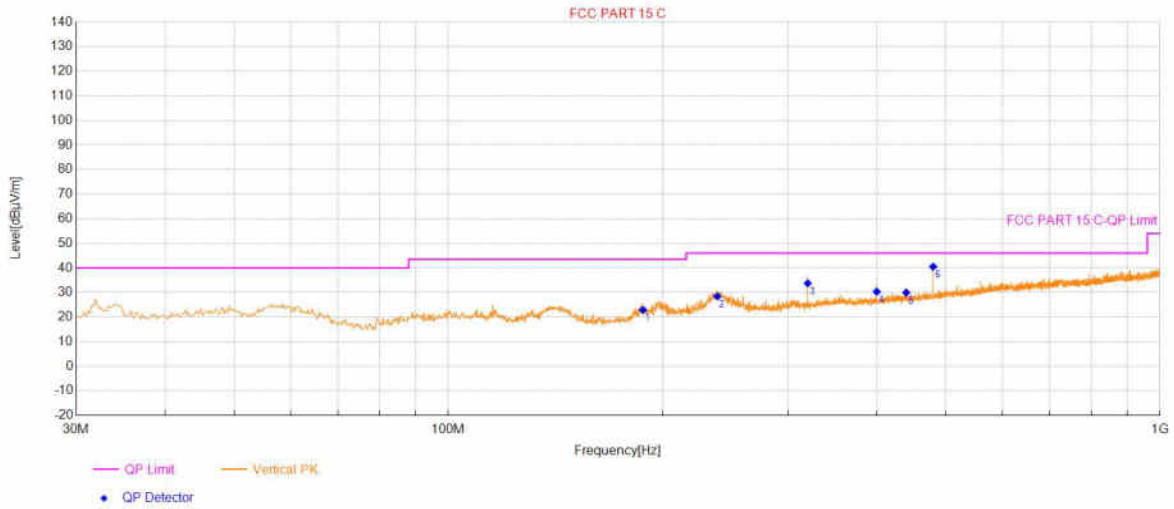

Final Data List									
NO.	Frequency (MHz)	Factor (dB/m)	QP Value (dBµV/m)	QP Limit (dBµV/m)	QP Margin (dB)	Height (cm)	Angle (°)	Polarity	Verdict
1	187.7536	19.22	22.92	43.50	20.58	100	71	Vertical	PASS
2	238.7858	21.64	28.43	46.00	17.57	100	319	Vertical	PASS
3	319.8940	23.84	33.77	46.00	12.23	100	35	Vertical	PASS
4	400.0320	25.72	30.34	46.00	15.66	100	62	Vertical	PASS
5	440.0040	26.39	29.95	46.00	16.05	100	328	Vertical	PASS
6	480.0078	27.35	40.48	46.00	5.52	100.1	53	Vertical	PASS

APPENDIX B – Radiated Emission Above 1GHz Test Data Test Report

Project Information			
Customer:			
EUT:	Portl UltraGym 70		
Model:	PUG-70	SN:	
Mode:	BLE_1M_2402	Voltage:	AC220V/60Hz
Environment:	Temp: 25°C; Humi:60%	Engineer:	Soho Liu
Remark:	Power Set:5		
Test Standard: FCC PART 15 C			

Start of Test:2024-08-20 17:34:31

Test Graph

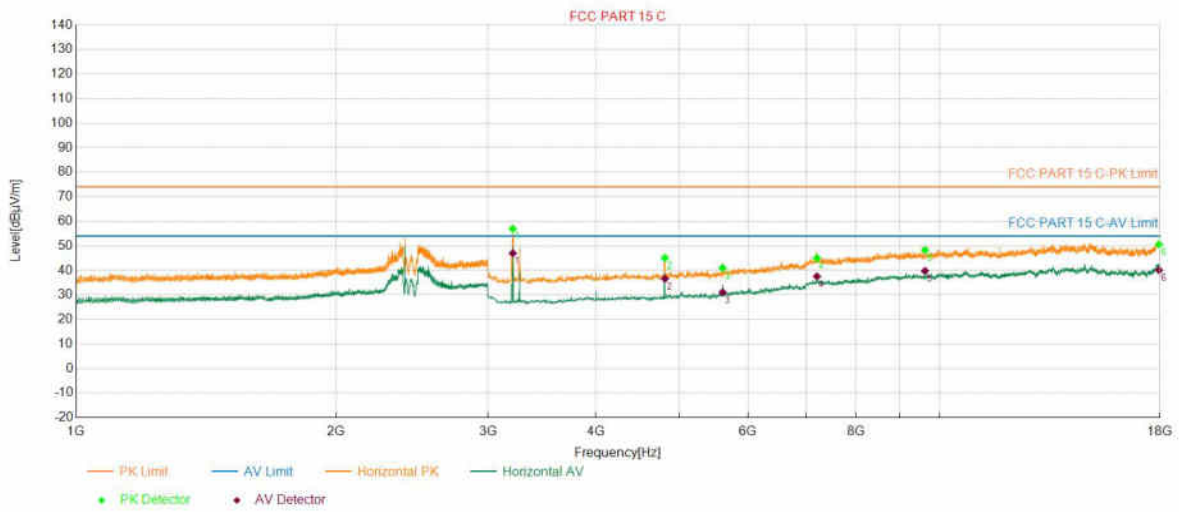

PK Final Data List											
NO.	Frequency (MHz)	Factor (dB/m)	PK Value (dBµV/m)	PK Limit (dBµV/m)	PK Margin (dB)	AV Value (dBµV/m)	AV Limit (dBµV/m)	AV Margin (dB)	Height (cm)	Angle (°)	Polarity
1	3204.0408	-10.52	56.96	74.00	17.04	46.98	54.00	7.02	100	112	Horizontal
2	4806.3613	-4.99	45.06	74.00	28.94	36.61	54.00	17.39	100	90	Horizontal
3	5607.5215	-2.64	41.03	74.00	32.97	31.09	54.00	22.91	100	81	Horizontal
4	7209.8420	3.37	45.00	74.00	29.00	37.56	54.00	16.44	100	59	Horizontal
5	9616.3233	7.94	48.31	74.00	25.69	39.78	54.00	14.22	100	300	Horizontal
6	17951.9904	21.05	50.60	74.00	23.40	40.09	54.00	13.91	100	1	Horizontal

Test Report

Project Information			
Customer:			
EUT:	Portl UltraGym 70		
Model:	PUG-70	SN:	
Mode:	BLE_1M_2402	Voltage:	AC220V/60Hz
Environment:	Temp: 25°C; Humi:60%	Engineer:	Soho Liu
Remark:	Power Set:5		
Test Standard: FCC PART 15 C			

Start of Test:2024-08-20 17:36:00

Test Graph

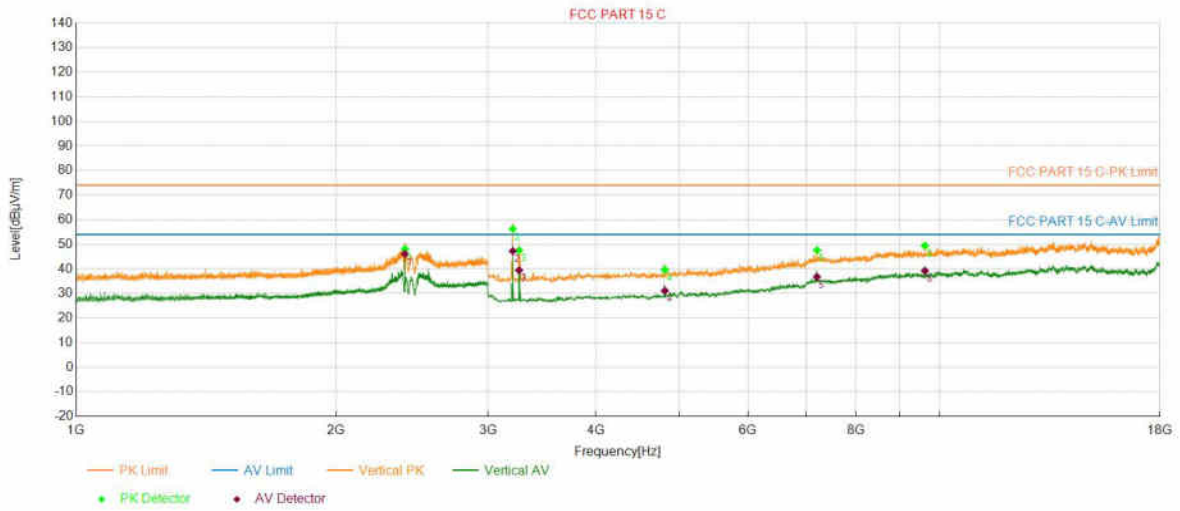

PK Final Data List											
NO.	Frequency (MHz)	Factor (dB/m)	PK Value (dBµV/m)	PK Limit (dBµV/m)	PK Margin (dB)	AV Value (dBµV/m)	AV Limit (dBµV/m)	AV Margin (dB)	Height (cm)	Angle (°)	Polarity
1	2403.8808	6.73	48.13	74.00	25.87	46.11	54.00	7.89	100	40	Vertical
2	3204.0408	-10.52	56.26	74.00	17.74	47.28	54.00	6.72	100	62	Vertical
3	3258.0516	-10.29	47.56	74.00	26.44	39.48	54.00	14.52	100	21	Vertical
4	4806.3613	-4.99	39.62	74.00	34.38	31.14	54.00	22.86	100	33	Vertical
5	7209.8420	3.37	47.67	74.00	26.33	36.79	54.00	17.21	100	93	Vertical
6	9616.3233	7.94	49.47	74.00	24.53	39.19	54.00	14.81	100	124	Vertical

Test Report

Project Information			
Customer:			
EUT:	Portl UltraGym 70		
Model:	PUG-70	SN:	
Mode:	BLE_1M_2440	Voltage:	AC220V/60Hz
Environment:	Temp: 25°C; Humi:60%	Engineer:	Soho Liu
Remark:	Power Set:5		
Test Standard: FCC PART 15 C			

Start of Test:2024-08-20 17:41:34

Test Graph

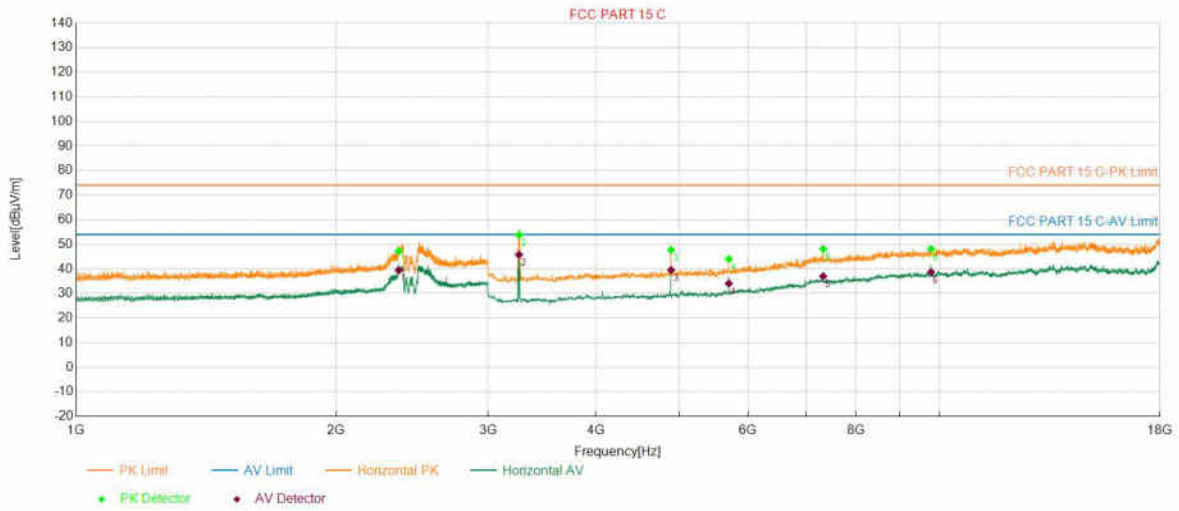

PK Final Data List

NO.	Frequency (MHz)	Factor (dB/m)	PK Value (dBµV/m)	PK Limit (dBµV/m)	PK Margin (dB)	AV Value (dBµV/m)	AV Limit (dBµV/m)	AV Margin (dB)	Height (cm)	Angle (°)	Polarity
1	2363.8728	6.48	47.27	74.00	26.73	39.47	54.00	14.53	100	102	Horizontal
2	3258.0516	-10.29	53.83	74.00	20.17	45.78	54.00	8.22	100	105	Horizontal
3	4887.3775	-4.38	47.68	74.00	26.32	39.55	54.00	14.45	100	105	Horizontal
4	5700.5401	-2.17	44.07	74.00	29.93	34.07	54.00	19.93	100	75	Horizontal
5	7329.8660	3.21	48.07	74.00	25.93	37.02	54.00	16.98	100	32	Horizontal
6	9775.3551	8.47	48.16	74.00	25.84	38.72	54.00	15.28	100	63	Horizontal

Test Report

Project Information			
Customer:			
EUT:	Portl UltraGym 70		
Model:	PUG-70	SN:	
Mode:	BLE_1M_2440	Voltage:	AC220V/60Hz
Environment:	Temp: 25°C; Humi:60%	Engineer:	Soho Liu
Remark:	Power Set:5		
Test Standard: FCC PART 15 C			

Start of Test:2024-08-20 17:43:14

Test Graph

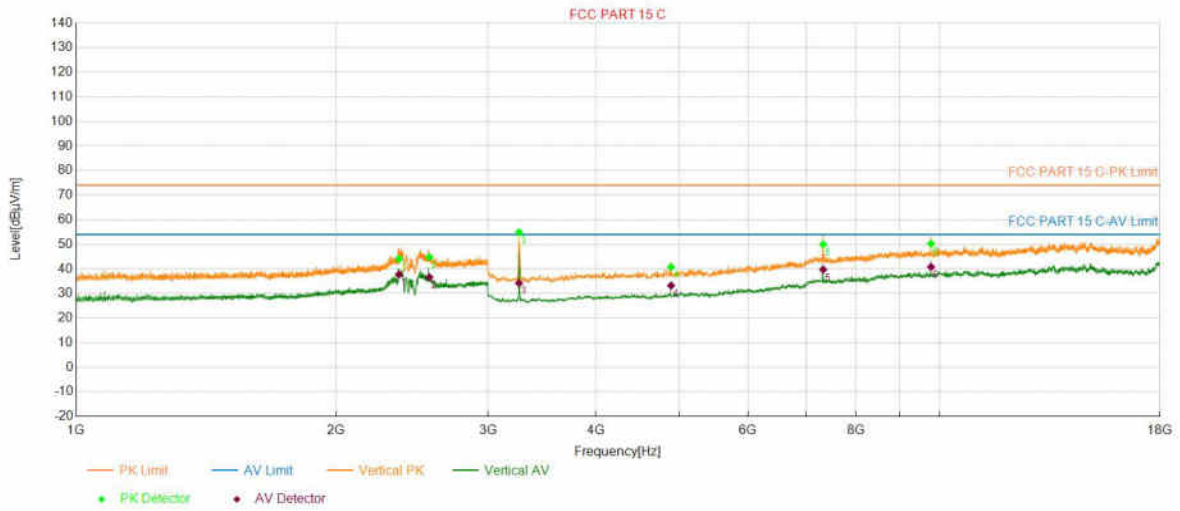

PK Final Data List											
NO.	Frequency (MHz)	Factor (dB/m)	PK Value (dBµV/m)	PK Limit (dBµV/m)	PK Margin (dB)	AV Value (dBµV/m)	AV Limit (dBµV/m)	AV Margin (dB)	Height (cm)	Angle (°)	Polarity
1	2365.0730	7.14	44.08	74.00	29.92	37.71	54.00	16.29	100	48	Vertical
2	2564.7129	5.55	44.79	74.00	29.21	36.62	54.00	17.38	100	39	Vertical
3	3258.0516	-10.29	54.90	74.00	19.10	34.22	54.00	19.78	100	40	Vertical
4	4887.3775	-4.38	40.76	74.00	33.24	33.26	54.00	20.74	100	112	Vertical
5	7329.8660	3.21	49.99	74.00	24.01	39.73	54.00	14.27	100	124	Vertical
6	9775.3551	8.47	50.23	74.00	23.77	40.79	54.00	13.21	100	124	Vertical

Test Report

Project Information			
Customer:			
EUT:	Portl UltraGym 70		
Model:	PUG-70	SN:	
Mode:	BLE_1M_2480	Voltage:	AC220V/60Hz
Environment:	Temp: 25°C; Humi:60%	Engineer:	Soho Liu
Remark:	Power Set:5		
Test Standard: FCC PART 15 C			

Start of Test:2024-08-20 17:46:42

Test Graph

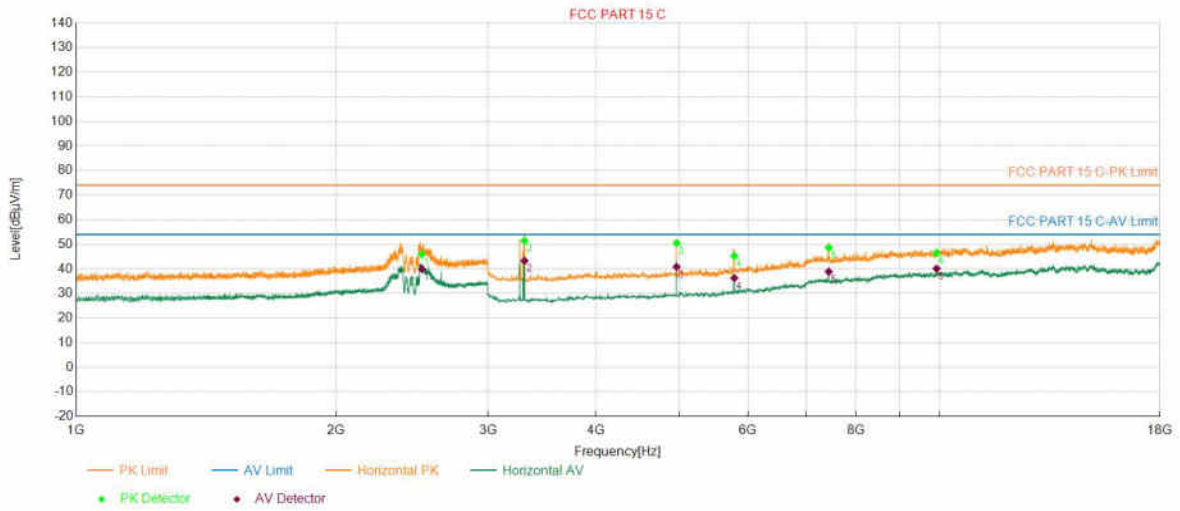

PK Final Data List

NO.	Frequency (MHz)	Factor (dB/m)	PK Value (dBµV/m)	PK Limit (dBµV/m)	PK Margin (dB)	AV Value (dBµV/m)	AV Limit (dBµV/m)	AV Margin (dB)	Height (cm)	Angle (°)	Polarity
1	2513.9028	5.92	45.98	74.00	28.02	39.95	54.00	14.05	100	102	Horizontal
2	3306.0612	-10.10	51.45	74.00	22.55	43.32	54.00	10.68	100	55	Horizontal
3	4959.3919	-4.16	50.51	74.00	23.49	40.82	54.00	13.18	100	117	Horizontal
4	5784.5569	-1.71	45.27	74.00	28.73	36.31	54.00	17.69	100	74	Horizontal
5	7440.8882	3.19	48.61	74.00	25.39	38.87	54.00	15.13	100	33	Horizontal
6	9919.3839	8.46	46.56	74.00	27.44	40.09	54.00	13.91	100	55	Horizontal

Test Report

Project Information			
Customer:			
EUT:	Portl UltraGym 70		
Model:	PUG-70	SN:	
Mode:	BLE_1M_2480	Voltage:	AC220V/60Hz
Environment:	Temp: 25°C; Humi:60%	Engineer:	Soho Liu
Remark:	Power Set:5		
Test Standard: FCC PART 15 C			

Start of Test:2024-08-20 17:48:12

Test Graph

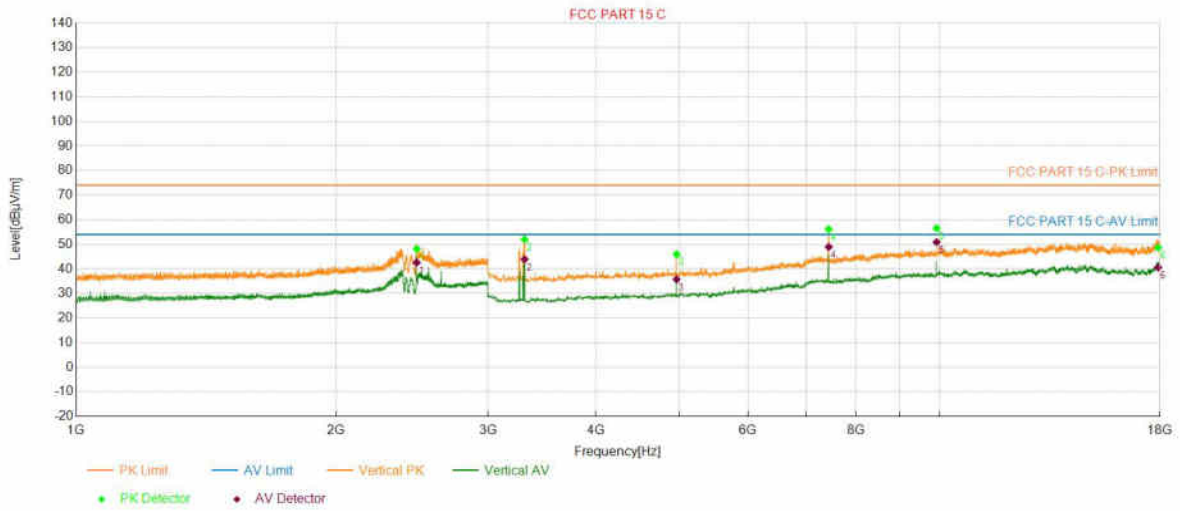

PK Final Data List											
NO.	Frequency (MHz)	Factor (dB/m)	PK Value (dBµV/m)	PK Limit (dBµV/m)	PK Margin (dB)	AV Value (dBµV/m)	AV Limit (dBµV/m)	AV Margin (dB)	Height (cm)	Angle (°)	Polarity
1	2479.8960	6.17	48.14	74.00	25.86	42.58	54.00	11.42	100	47	Vertical
2	3306.0612	-10.10	51.98	74.00	22.02	43.93	54.00	10.07	100	39	Vertical
3	4959.3919	-4.16	45.94	74.00	28.06	35.77	54.00	18.23	100	29	Vertical
4	7440.3933	3.19	56.16	74.00	17.84	48.95	54.00	5.05	108.1	126	Vertical
5	9919.8644	8.46	56.53	74.00	17.47	50.91	54.00	3.09	100	124	Vertical
6	17912.9826	21.06	48.69	74.00	25.31	40.59	54.00	13.41	100	51	Vertical

Test Report

Project Information			
Customer:			
EUT:	Portl UltraGym 70		
Model:	PUG-70	SN:	
Mode:	BLE_1M_2402	Voltage:	AC220V/60Hz
Environment:	Temp: 25°C; Humi:60%	Engineer:	Soho Liu
Remark:	Power Set:5		
Test Standard: FCC Part15 C			

Start of Test:2024-08-20 17:38:55

Test Graph

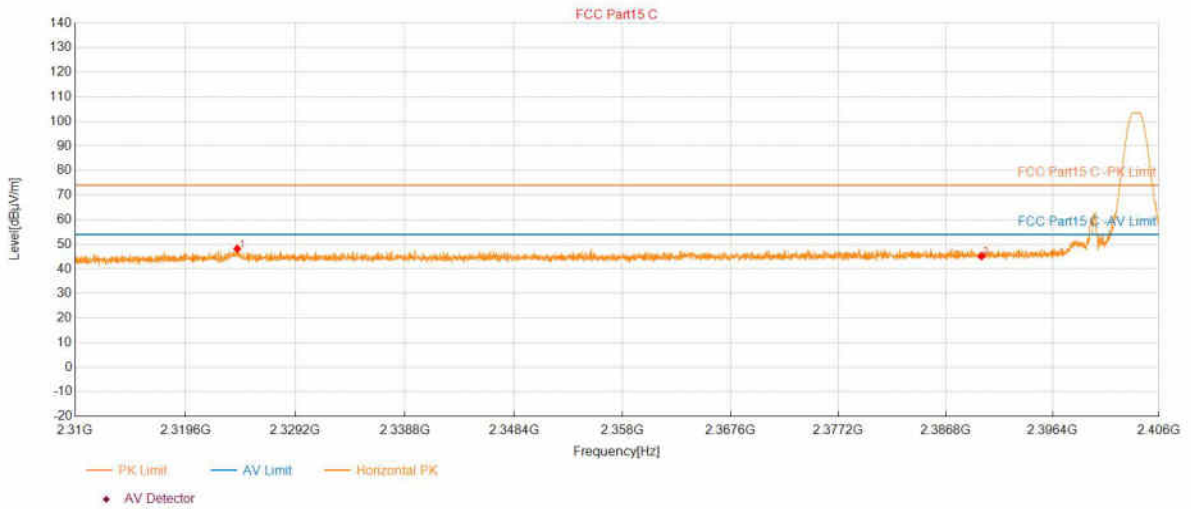

Suspected Data List							
NO.	Frequency (MHz)	Level (dBµV/m)	Limit (dBµV/m)	Margin (dB)	Height (cm)	Angle (°)	Polarity
1	2324.11	48.21	74.00	25.79	100	102	Horizontal
2	2390.00	45.13	74.00	28.87	100	112	Horizontal

Test Report

Project Information			
Customer:			
EUT:	Portl UltraGym 70		
Model:	PUG-70	SN:	
Mode:	BLE_1M_2402	Voltage:	AC220V/60Hz
Environment:	Temp: 25°C; Humi:60%	Engineer:	Soho Liu
Remark:	Power Set:5		
Test Standard: FCC Part15 C			

Start of Test:2024-08-20 17:39:41

Test Graph

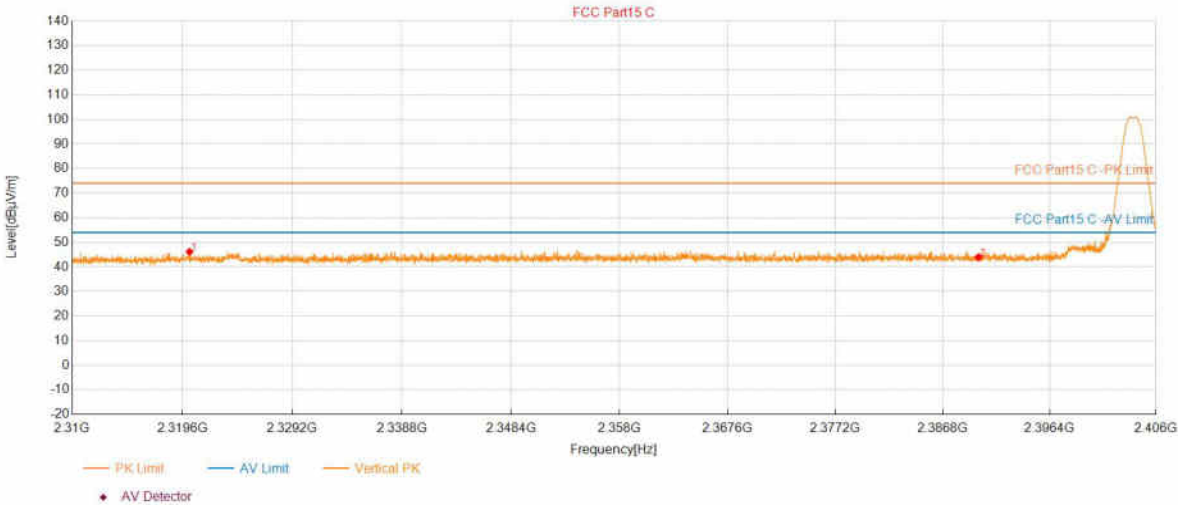

Suspected Data List							
NO.	Frequency (MHz)	Level (dBµV/m)	Limit (dBµV/m)	Margin (dB)	Height (cm)	Angle (°)	Polarity
1	2320.22	46.16	74.00	27.84	100	38	Vertical
2	2390.00	43.92	74.00	30.08	100	38	Vertical

Test Report

Project Information			
Customer:			
EUT:	Portl UltraGym 70		
Model:	PUG-70	SN:	
Mode:	BLE_1M_2480	Voltage:	AC220V/60Hz
Environment:	Temp: 25°C; Humi:60%	Engineer:	Soho Liu
Remark:	Power Set:5		
Test Standard: FCC Part15 C			

Start of Test:2024-08-20 17:54:26

Test Graph

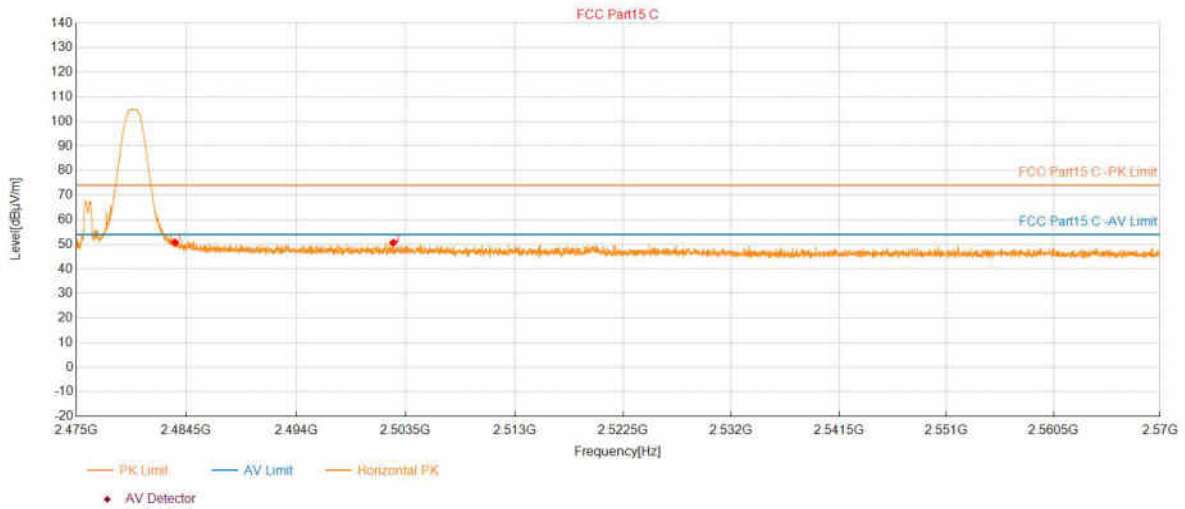

Suspected Data List							
NO.	Frequency (MHz)	Level (dBµV/m)	Limit (dBµV/m)	Margin (dB)	Height (cm)	Angle (°)	Polarity
1	2483.51	50.76	74.00	23.24	100	97	Horizontal
2	2502.42	50.62	74.00	23.38	100	97	Horizontal

Test Report

Project Information			
Customer:			
EUT:	Portl UltraGym 70		
Model:	PUG-70	SN:	
Mode:	BLE_1M_2480	Voltage:	AC220V/60Hz
Environment:	Temp: 25°C; Humi:60%	Engineer:	Soho Liu
Remark:	Power Set:5		
Test Standard: FCC Part15 C			

Start of Test:2024-08-20 17:55:12

Test Graph

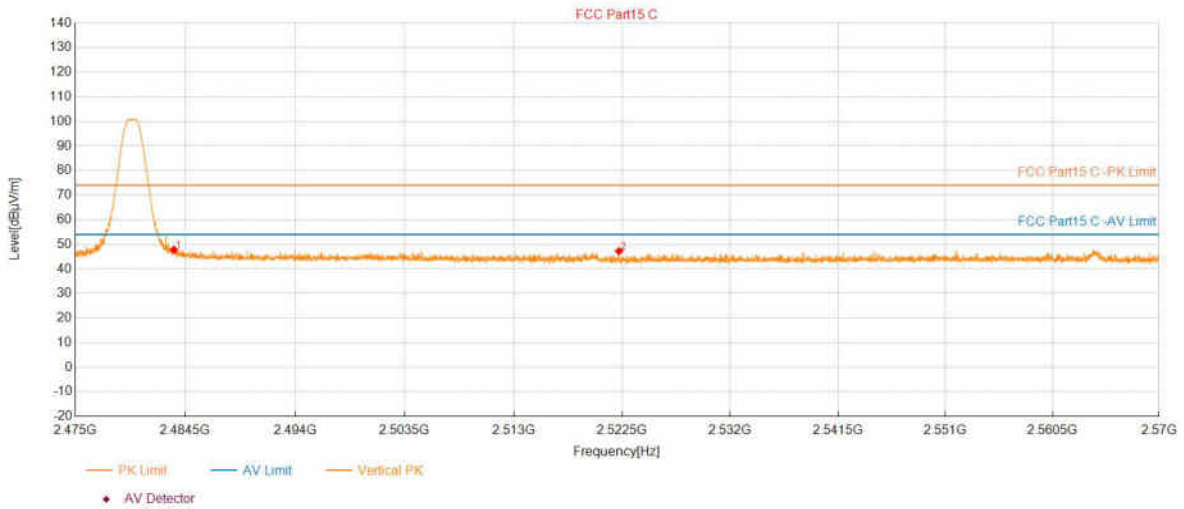

Suspected Data List							
NO.	Frequency (MHz)	Level (dBµV/m)	Limit (dBµV/m)	Margin (dB)	Height (cm)	Angle (°)	Polarity
1	2483.51	47.83	74.00	26.17	100	352	Vertical
2	2522.22	47.23	74.00	26.77	100	45	Vertical

APPENDIX C – AC Power Line Conducted Emission Test Data

