

RF TEST REPORT

Applicant Roadeazy
FCC ID 2BKST-RZ1VH2401
Product AI Vehicle Gateway
Model RZ1
Report No. R2408A1127-R4
Issue Date October 29, 2024

Eurofins TA Technology (Shanghai) Co., Ltd. tested the above equipment in accordance with the requirements in **FCC CFR47 Part 2 (2022)/FCC CFR 47 Part 90R (2022)**. The test results show that the equipment tested is capable of demonstrating compliance with the requirements as documented in this report.

Prepared by: Xu Ying

Approved by: Xu Kai

Eurofins TA Technology (Shanghai) Co., Ltd.

Building 3, No.145, Jintang Rd, Pudong Shanghai, P.R.China

TEL: +86-021-50791141/2/3

FAX: +86-021-50791141/2/3-8000

TABLE OF CONTENT

1. Test Laboratory	4
1.1. Notes of the Test Report	4
1.2. Test Facility	4
1.3. Testing Location	4
2. General Description of Equipment Under Test	5
2.1. Applicant and Manufacturer Information	5
2.2. General Information	5
3. Applied Standards	6
4. Test Configuration	7
5. Test Case	8
5.1. RF Power Output and Effective Radiated Power	8
5.2. Radiated Spurious Emission	9
6. Test Result	12
6.1. RF Power Output and Effective Radiated Power	12
6.2. Radiated Spurious Emission	14
7. Main Test Instruments	15
ANNEX A: The EUT Appearance	16
ANNEX B: Test Setup Photos	17

Summary of Measurement Results

No.	Test Case	Clause in FCC rules	Verdict
1	RF power output and Effective Radiated Power	2.1046/90.635 (b)/ 90.542	PASS
2	Radiated Spurious Emission	90.543 (e)	PASS
Date of Testing: September 5, 2024 ~ September 11, 2024			
Date of Sample Received: August 22, 2024			
Note: PASS: The EUT complies with the essential requirements in the standard. FAIL: The EUT does not comply with the essential requirements in the standard. All indications of Pass/Fail in this report are opinions expressed by Eurofins TA Technology (Shanghai) Co., Ltd. based on interpretations and/or observations of test results. Measurement Uncertainties were not taken into account and are published for informational purposes only.			

Only Radiated Spurious Emission is tested for RZ1 in this report, and because of the change of antenna gain, Effective Radiated Power also re evaluated. Other test items refer to the Module report (Report No.: 200722022RFM-3, FCC ID: QIPPLS83-X; Grant date: 08/30/2023).

1. Test Laboratory

1.1. Notes of the Test Report

This report shall not be reproduced in full or partial, without the written approval of **Eurofins TA Technology (Shanghai) Co., Ltd.** The results documented in this report apply only to the tested sample, under the conditions and modes of operation as described herein. Measurement Uncertainties were not taken into account and are published for informational purposes only. This report is written to support regulatory compliance of the applicable standards stated above.

1.2. Test Facility

FCC (Designation number: CN1179, Test Firm Registration Number: 446626)

Eurofins TA Technology (Shanghai) Co., Ltd. has been listed on the US Federal Communications Commission list of test facilities recognized to perform electromagnetic emissions measurements.

A2LA (Certificate Number: 3857.01)

Eurofins TA Technology (Shanghai) Co., Ltd. has been listed by American Association for Laboratory Accreditation to perform electromagnetic emission measurement.

1.3. Testing Location

Company: Eurofins TA Technology (Shanghai) Co., Ltd.
Address: Building 3, No.145, Jintang Rd, Pudong Shanghai, P.R.China
City: Shanghai
Post code: 201201
Country: P. R. China
Contact: Xu Kai
Telephone: +86-021-50791141/2/3
Fax: +86-021-50791141/2/3-8000
Website: <https://www.eurofins.com/electrical-and-electronics>
E-mail: Kain.Xu@cpt.eurofinscn.com

2. General Description of Equipment Under Test

2.1. Applicant and Manufacturer Information

Applicant	Roadeazy
Applicant address	1386 Enderby Way, Sunnyvale, CA USA
Manufacturer	Asiatelco Technologies Co.
Manufacturer address	#68 HuaTuo Road, Building-8, Zhangjiang Hi-Tech Park, Pudong, Shanghai 201204, China

2.2. General Information

EUT Description			
Model	RZ1		
IMEI	869254069966498		
Hardware Version	P2		
Software Version	V2		
Power Supply	External power supply		
Antenna Type	Internal Antenna		
Antenna Gain	1.4 dBi		
Test Mode(s)	LTE Band 14		
Test Modulation	QPSK, 16QAM;		
Maximum E.R.P.	22.38 dBm		
Rated Power Supply Voltage	24V		
Operating Voltage	Minimum: 9V Maximum: 32V		
Operating Temperature	Lowest: -40°C Highest: +85°C		
Operating Frequency Range(s)	Band	Tx (MHz)	Rx (MHz)
	LTE Band 14	788 ~ 798	758 ~ 768
Note: The EUT is sent from the applicant to Eurofins TA and the information of the EUT is declared by the applicant.			

3. Applied Standards

According to the specifications of the manufacturer, it must comply with the requirements of the following standards:

Test standards:

FCC CFR 47 Part 90R (2022)

ANSI C63.26-2015

Reference standard:

FCC 47 CFR Part 2 (2022)

KDB 971168 D01 Power Meas License Digital Systems v03r01

4. Test Configuration

Radiated measurements are performed by rotating the EUT in three different orthogonal test planes. EUT stand-up position (Z axis), lie-down position (X, Y axis). Receiver antenna polarization (horizontal and vertical), the worst emission was found in position (X axis, horizontal polarization) and the worst case was recorded.

All mode and data rates and positions were investigated.

The following testing in LTE is set based on the maximum RF Output Power.

Test modes are chosen as the worst case configuration below for LTE Band 14

Test items	Bandwidth (MHz)		Modulation		RB			Test Channel		
	5	10	QPSK	16QAM	1	50%	100%	L	M	H
RF Power Output and Effective Radiated Power	O	O	O	O	O	O	O	O	O	O
Radiated Spurious Emission	O	O	O	-	O	-	-	-	O	-
Note	1. The mark "O" means that this configuration is chosen for testing. 2. The mark "-" means that this configuration is not testing.									

5. Test Case

5.1. RF Power Output and Effective Radiated Power

Ambient Condition

Temperature	Relative humidity	Pressure
15°C ~ 35°C	20% ~ 80%	86 kPa ~ 106 kPa

Methods of Measurement

During the process of the testing, The EUT was connected to the Base Station Simulator with a known loss. The EUT is controlled by the Base Station Simulator test set to ensure max power transmission with proper modulation.

ERP can then be calculated as follows:

$EIRP \text{ (dBm)} = \text{Output Power (dBm)} + \text{Antenna Gain (dBi)}$

$EIRP \text{ (dBm)} = ERP \text{ (dBm)} + 2.15 \text{ (dB.)}$

Test Setup

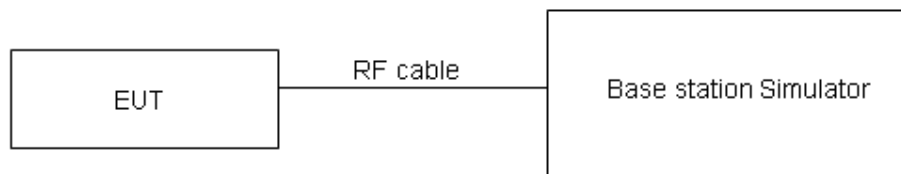

Limits

Part 90.635 (b) the maximum output power of the transmitter for mobile stations is 100 watts.

90.542(7) Portable stations (hand-held devices) transmitting in the 758-768 MHz band and the 788-798 MHz band are limited to 3 watts ERP.

Measurement Uncertainty

The assessed measurement uncertainty to ensure 95% confidence level for the normal distribution is with the coverage factor $k = 2$, $U = 0.4 \text{ dB}$ for RF power output, $k = 2$, $U = 1.19 \text{ dB}$ for ERP.

Test Results

Refer to the section 6.1 of this report for test data.

5.2. Radiated Spurious Emission

Ambient Condition

Temperature	Relative humidity	Pressure
15°C ~ 35°C	20% ~ 80%	86 kPa ~ 106 kPa

Method of Measurement

1. The testing follows FCC KDB 971168 D01 v03r01 Section 5.8 and ANSI C63.26.
2. Above 30MHz: The EUT is placed on a turntable 0.8 meters above the ground in the chamber, 3 meter away from the antenna. The maximal emission value is acquired by adjusting the antenna height, polarisation and turntable azimuth. Normally, the height range of antenna is 1 m to 4 m, the azimuth range of turntable is 0° to 360° , and the receive antenna has two polarizations Vertical (V) and Horizontal (H). Above 1GHz: (Note: the FCC' s permission to use 1.5m as an alternative per TCBC Conf call of Dec. 2, 2014.) The EUT is placed on a turntable 1.5 meters above the ground in the chamber, 3 meter away from the antenna. The maximal emission value is acquired by adjusting the antenna height, polarisation and turntable azimuth. Normally, the height range of antenna is 1 m to 4 m, the azimuth range of turntable is 0° to 360° , and the receive antenna has two polarizations Vertical (V) and Horizontal (H).
3. A loop antenna, A log-periodic antenna or horn antenna shall be substituted in place of the EUT. The log-periodic antenna will be driven by a signal generator and the level will be adjusted till the same power value on the spectrum analyzer or receiver. The level of the spurious emissions can be calculated through the level of the signal generator, cable loss, the gain of the substitution antenna and the reading of the spectrum analyzer or receiver.
4. The EUT is then put into continuously transmitting mode at its maximum power level during the test. Set Test Receiver or Spectrum RBW=100KHz, VBW=300KHz for all frequency, and the maximum value of the receiver should be recorded as (Pr).
5. The EUT shall be replaced by a substitution antenna. In the chamber, an substitution antenna for the frequency band of interest is placed at the reference point of the chamber. An RF Signal source for the frequency band of interest is connected to the substitution antenna with a cable that has been constructed to not interfere with the radiation pattern of the antenna. A power (PMea) is applied to the input of the substitution antenna, and adjust the level of the signal generator output until the value of the receiver reach the previously recorded (Pr). The power of signal source (PMea) is recorded. The test should be performed by rotating the test item and adjusting the receiving antenna polarization.
6. A amplifier should be connected to the Signal Source output port. And the cable should be connect between the Amplifier and the Substitution Antenna. The cable loss (Pcl) ,the Substitution Antenna Gain (Ga) and the Amplifier Gain (PAg) should be recorded after test.
7. The measurement results are obtained as described below:

$$\text{Power(EIRP)} = \text{PMea} - \text{PAg} - \text{Pcl} + \text{Ga}$$
 The measurement results are amend as described below:

$$\text{Power(EIRP)} = \text{PMea} - \text{Pcl} + \text{Ga}$$
8. This value is EIRP since the measurement is calibrated using an antenna of known gain (2.15 dBi) and known input power. ERP can be calculated from EIRP by subtracting the gain of the dipole, $\text{ERP} = \text{EIRP} - 2.15\text{dBi}$.

The modulation mode and RB allocation refer to section 5.1, using the maximum output power configuration.

Test Setup

9KHz ~ 30MHz

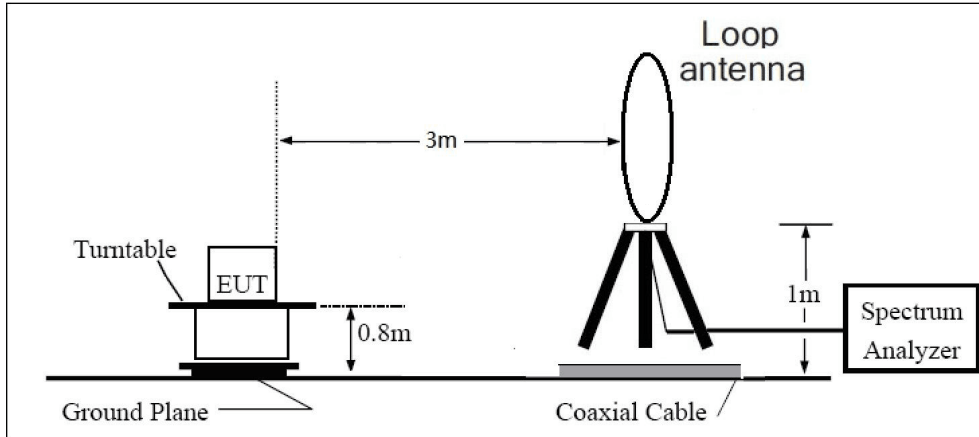

30MHz ~ 1GHz

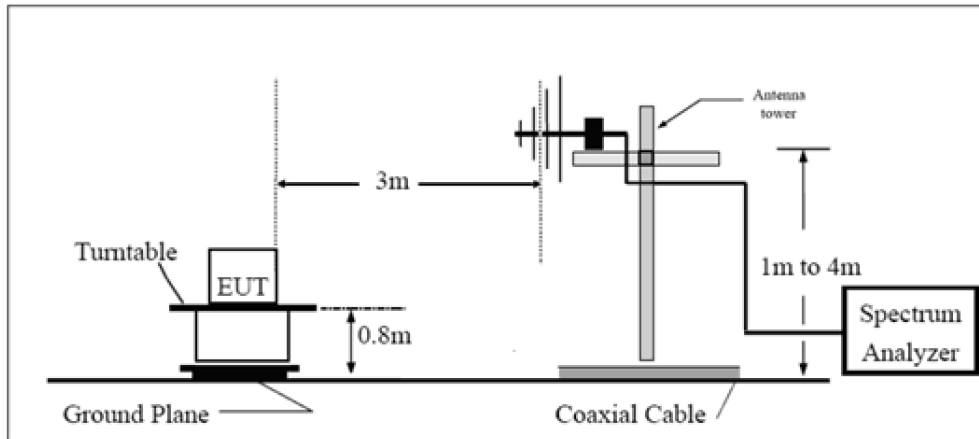

Above 1GHz

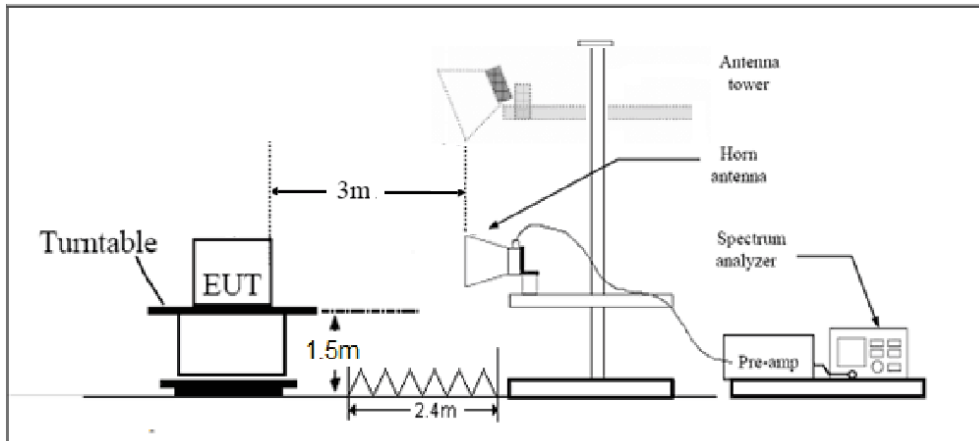

Note: Area side: 2.4mX3.6m

Limits

90.543 Emission limitations (e) For operations in the 758-768 MHz and the 788-798 MHz bands, the power of any emission outside the licensee's frequency band(s) of operation shall be attenuated below the transmitter power (P) within the licensed band(s) of operation, measured in watts, in accordance with the following:

- (1) On all frequencies between 769-775 MHz and 799-805 MHz, by a factor not less than $76 + 10 \log(P)$ dB in a 6.25 kHz band segment, for base and fixed stations.
- (2) On all frequencies between 769-775 MHz and 799-805 MHz, by a factor not less than $65 + 10 \log(P)$ dB in a 6.25 kHz band segment, for mobile and portable stations.
- (3) On any frequency between 775-788 MHz, above 805 MHz, and below 758 MHz, by at least $43 + 10 \log(P)$ dB.
- (4) Compliance with the provisions of paragraphs (e)(1) and (2) of this section is based on the use of measurement instrumentation such that the reading taken with any resolution bandwidth setting should be adjusted to indicate spectral energy in a 6.25 kHz segment.
- (5) Compliance with the provisions of paragraph (e)(3) of this section is based on the use of measurement instrumentation employing a resolution bandwidth of 100 kHz or greater. However, in the 100 kHz bands immediately outside and adjacent to the frequency block, a resolution bandwidth of 30 kHz may be employed.
- (f) For operations in the 758-775 MHz and 788-805 MHz bands, all emissions including harmonics in the band 1559-1610 MHz shall be limited to -70 dBW/MHz equivalent isotropically radiated power (EIRP) for wideband signals, and -80 dBW EIRP for discrete emissions of less than 700 Hz bandwidth. For the purpose of equipment authorization, a transmitter shall be tested with an antenna that is representative of the type that will be used with the equipment in normal operation.

Measurement Uncertainty

The assessed measurement uncertainty to ensure 95% confidence level for the normal distribution is with the coverage factor $k = 1.96$, $U = 3.55$ dB.

Test Results

Refer to the section 6.2 of this report for test data.

6. Test Result

6.1. RF Power Output and Effective Radiated Power

Band	Bandwidth (MHz)	UL Channel	RB Size	RB Position	Modulation	Power (dBm)	EPR (dBm)
LTE Band14	5	23305	1	#0	QPSK	22.65	21.90
LTE Band14	5	23305	1	#Mid	QPSK	22.90	22.15
LTE Band14	5	23305	1	#Max	QPSK	22.80	22.05
LTE Band14	5	23305	12	#0	QPSK	22.00	21.25
LTE Band14	5	23305	12	#Mid	QPSK	22.00	21.25
LTE Band14	5	23305	12	#Max	QPSK	22.05	21.30
LTE Band14	5	23305	25	#0	QPSK	22.02	21.27
LTE Band14	5	23305	1	#0	16QAM	22.15	21.40
LTE Band14	5	23305	1	#Mid	16QAM	22.65	21.90
LTE Band14	5	23305	1	#Max	16QAM	22.32	21.57
LTE Band14	5	23305	12	#0	16QAM	20.87	20.12
LTE Band14	5	23305	12	#Mid	16QAM	20.88	20.13
LTE Band14	5	23305	12	#Max	16QAM	20.94	20.19
LTE Band14	5	23305	25	#0	16QAM	20.95	20.20
LTE Band14	5	23330	1	#0	QPSK	22.81	22.06
LTE Band14	5	23330	1	#Mid	QPSK	22.90	22.15
LTE Band14	5	23330	1	#Max	QPSK	22.93	22.18
LTE Band14	5	23330	12	#0	QPSK	22.13	21.38
LTE Band14	5	23330	12	#Mid	QPSK	22.13	21.38
LTE Band14	5	23330	12	#Max	QPSK	22.09	21.34
LTE Band14	5	23330	25	#0	QPSK	22.04	21.29
LTE Band14	5	23330	1	#0	16QAM	21.71	20.96
LTE Band14	5	23330	1	#Mid	16QAM	21.84	21.09
LTE Band14	5	23330	1	#Max	16QAM	21.88	21.13
LTE Band14	5	23330	12	#0	16QAM	20.83	20.08
LTE Band14	5	23330	12	#Mid	16QAM	20.83	20.08
LTE Band14	5	23330	12	#Max	16QAM	20.80	20.05
LTE Band14	5	23330	25	#0	16QAM	20.82	20.07
LTE Band14	5	23355	1	#0	QPSK	22.79	22.04
LTE Band14	5	23355	1	#Mid	QPSK	22.91	22.16
LTE Band14	5	23355	1	#Max	QPSK	22.74	21.99
LTE Band14	5	23355	12	#0	QPSK	22.00	21.25
LTE Band14	5	23355	12	#Mid	QPSK	22.00	21.25
LTE Band14	5	23355	12	#Max	QPSK	22.03	21.28
LTE Band14	5	23355	25	#0	QPSK	22.02	21.27
LTE Band14	5	23355	1	#0	16QAM	21.71	20.96

LTE Band14	5	23355	1	#Mid	16QAM	21.84	21.09
LTE Band14	5	23355	1	#Max	16QAM	21.75	21.00
LTE Band14	5	23355	12	#0	16QAM	20.96	20.21
LTE Band14	5	23355	12	#Mid	16QAM	21.03	20.28
LTE Band14	5	23355	12	#Max	16QAM	21.14	20.39
LTE Band14	5	23355	25	#0	16QAM	21.01	20.26
LTE Band14	10	23330	1	#0	QPSK	23.13	22.38
LTE Band14	10	23330	1	#Mid	QPSK	23.05	22.30
LTE Band14	10	23330	1	#Max	QPSK	23.01	22.26
LTE Band14	10	23330	25	#0	QPSK	22.09	21.34
LTE Band14	10	23330	25	#Mid	QPSK	22.09	21.34
LTE Band14	10	23330	25	#Max	QPSK	22.06	21.31
LTE Band14	10	23330	50	#0	QPSK	22.07	21.32
LTE Band14	10	23330	1	#0	16QAM	22.12	21.37
LTE Band14	10	23330	1	#Mid	16QAM	23.01	22.26
LTE Band14	10	23330	1	#Max	16QAM	22.33	21.58
LTE Band14	10	23330	25	#0	16QAM	21.27	20.52
LTE Band14	10	23330	25	#Mid	16QAM	21.27	20.52
LTE Band14	10	23330	25	#Max	16QAM	21.26	20.51
LTE Band14	10	23330	50	#0	16QAM	21.04	20.29

6.2. Radiated Spurious Emission

Sweep the whole frequency band through the range from 9kHz to the 10th harmonic of the carrier, the emissions below the noise floor will not be recorded in the report.

LTE Band 14 QPSK 5MHz CH-Middle, RB 1

Harmonic	Frequency (MHz)	SG (dBm)	Cable Loss (dB)	Gain (dBi)	Antenna Polarization	Result Level (dBm)	Limit (dBm)	Margin (dB)	Azimuth (deg)
2	1581.00	-56.07	1.70	8.70	Horizontal	-51.22	-40.00	11.22	205
3	2374.00	-36.99	2.30	12.00	Horizontal	-29.44	-13.00	16.44	177
4	3167.00	-57.49	2.30	13.10	Horizontal	-48.84	-13.00	35.84	47
5	3960.00	-64.66	2.90	12.50	Horizontal	-57.21	-13.00	44.21	21
6	4753.00	-63.99	3.10	12.50	Horizontal	-56.74	-13.00	43.74	315
7	5546.00	-60.75	3.30	12.50	Horizontal	-53.70	-13.00	40.70	99
8	6339.00	-58.34	3.80	11.50	Horizontal	-52.79	-13.00	39.79	163
9	7132.00	-54.74	4.20	11.80	Horizontal	-49.29	-13.00	36.29	177
10	7925.00	-52.45	4.40	12.30	Horizontal	-46.70	-13.00	33.70	90

Note: 1. The other Spurious RF Radiated emissions level is no more than noise floor.
 2. The worst emission was found in the antenna is Horizontal position.

LTE Band 14 QPSK 10MHz CH-Middle, RB 1

Harmonic	Frequency (MHz)	SG (dBm)	Cable Loss (dB)	Gain (dBi)	Antenna Polarization	Result Level (dBm)	Limit (dBm)	Margin (dB)	Azimuth (deg)
2	1576.00	-55.40	1.70	8.70	Horizontal	-50.55	-40.00	10.55	214
3	2369.00	-34.86	2.30	12.00	Horizontal	-27.31	-13.00	14.31	159
4	3162.00	-56.67	2.30	13.10	Horizontal	-48.02	-13.00	35.02	128
5	3955.00	-64.91	2.90	12.50	Horizontal	-57.46	-13.00	44.46	96
6	4748.00	-63.87	3.10	12.50	Horizontal	-56.62	-13.00	43.62	39
7	5541.00	-61.53	3.30	12.50	Horizontal	-54.48	-13.00	41.48	144
8	6334.00	-57.46	3.80	11.50	Horizontal	-51.91	-13.00	38.91	257
9	7127.00	-55.27	4.20	11.80	Horizontal	-49.82	-13.00	36.82	254
10	7920.00	-52.69	4.40	12.30	Horizontal	-46.94	-13.00	33.94	171

Note: 1. The other Spurious RF Radiated emissions level is no more than noise floor.
 2. The worst emission was found in the antenna is Horizontal position.

7. Main Test Instruments

Name	Manufacturer	Type	Serial Number	Calibration Date	Expiration Date
Wireless Communication Tester	R&S	CMW500	150415	2024-05-07	2025-05-06
Spectrum Analyzer	R&S	FSV30	100815	2023-12-05	2024-12-04
High-pass filter	Chengyi	HPF 1000MHz	2024021	2024-02-21	2025-02-21
High-pass filter	R&S	HPF 1500MHz	HPF 002	2024-02-21	2025-02-21
High-pass filter	R&S	HPF 3000MHz	HPF 003	2024-02-21	2025-02-21
Loop Antenna	SCHWARZBECK	FMZB1519	1519-047	2023-04-16	2026-04-15
TRILOG Broadband Antenna	SCHWARZBECK	VULB 9163	391	2022-09-29	2025-09-28
Horn Antenna	SCHWARZBECK	BBHA 9120D	1594	2023-12-05	2026-12-04
Software	R&S	EMC32	10.35.10	/	/

ANNEX A: The EUT Appearance

The EUT Appearance are submitted separately.

ANNEX B: Test Setup Photos

The Test Setup Photos are submitted separately.

***** END OF REPORT *****