

# ENGLISH

## APP INSTALL

EN

### APP Installation

PLEASE SCAN THE QR CODE BELOW OR SEARCH FOR 'CARGO CONTAINER' ON GOOGLE PLAY STORE OR APP STORE TO INSTALL THE APP.



SEARCH FOR  
'CARGO CONTAINER'  
IN THE SEARCH BAR.



SEARCH FOR  
'CARGO CONTAINER'  
IN THE SEARCH BAR.



## Language Setting

**a** THIS IS THE HOME SCREEN OF THE APP. TAP THE LIST BUTTON ON THE TOP RIGHT CORNER TO ACCESS THE SETTINGS MENU.



**b** SELECT 'LANGUAGE'.

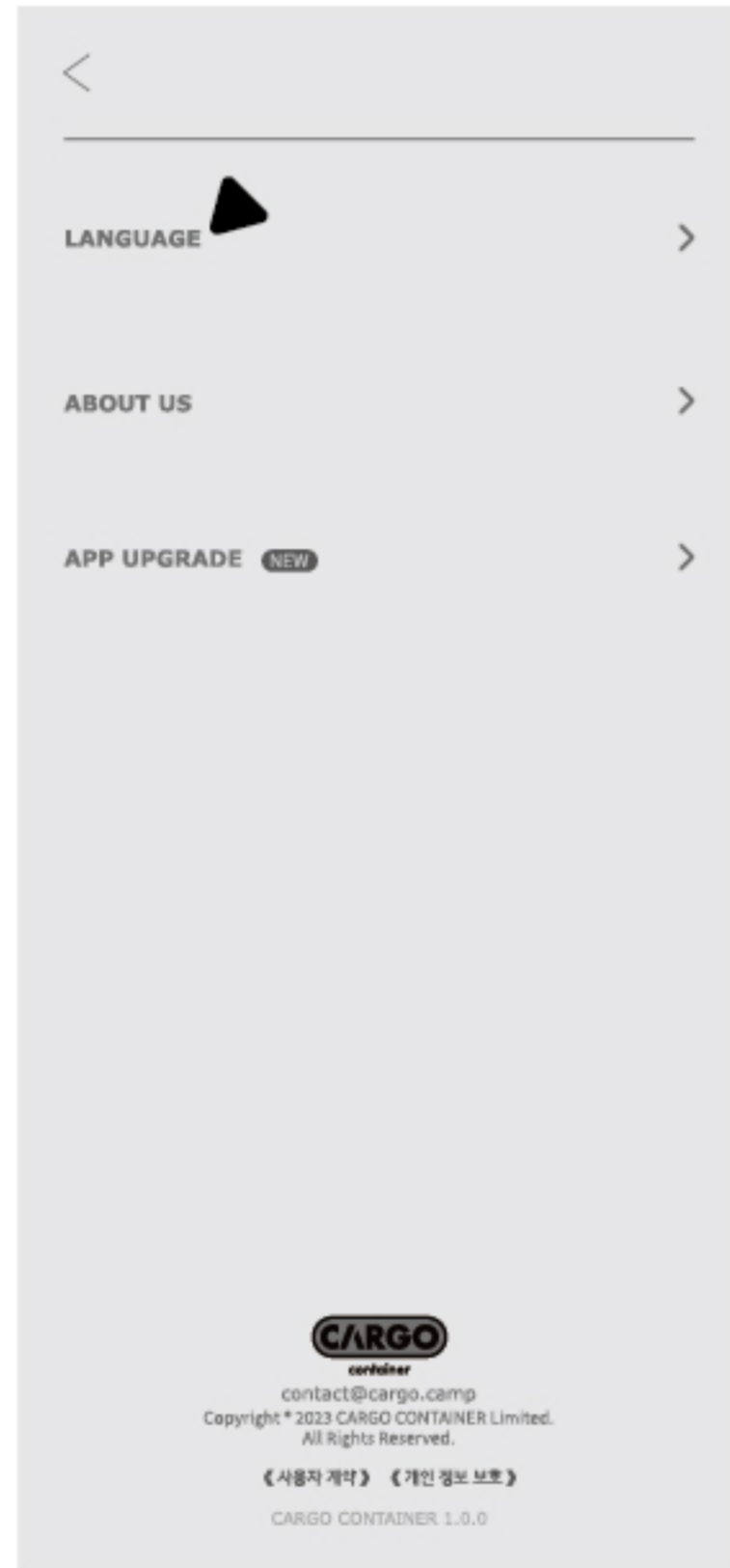

**c** CHOOSE YOUR DESIRED LANGUAGE FROM THE SUPPORTED LANGUAGES IN THE APP.

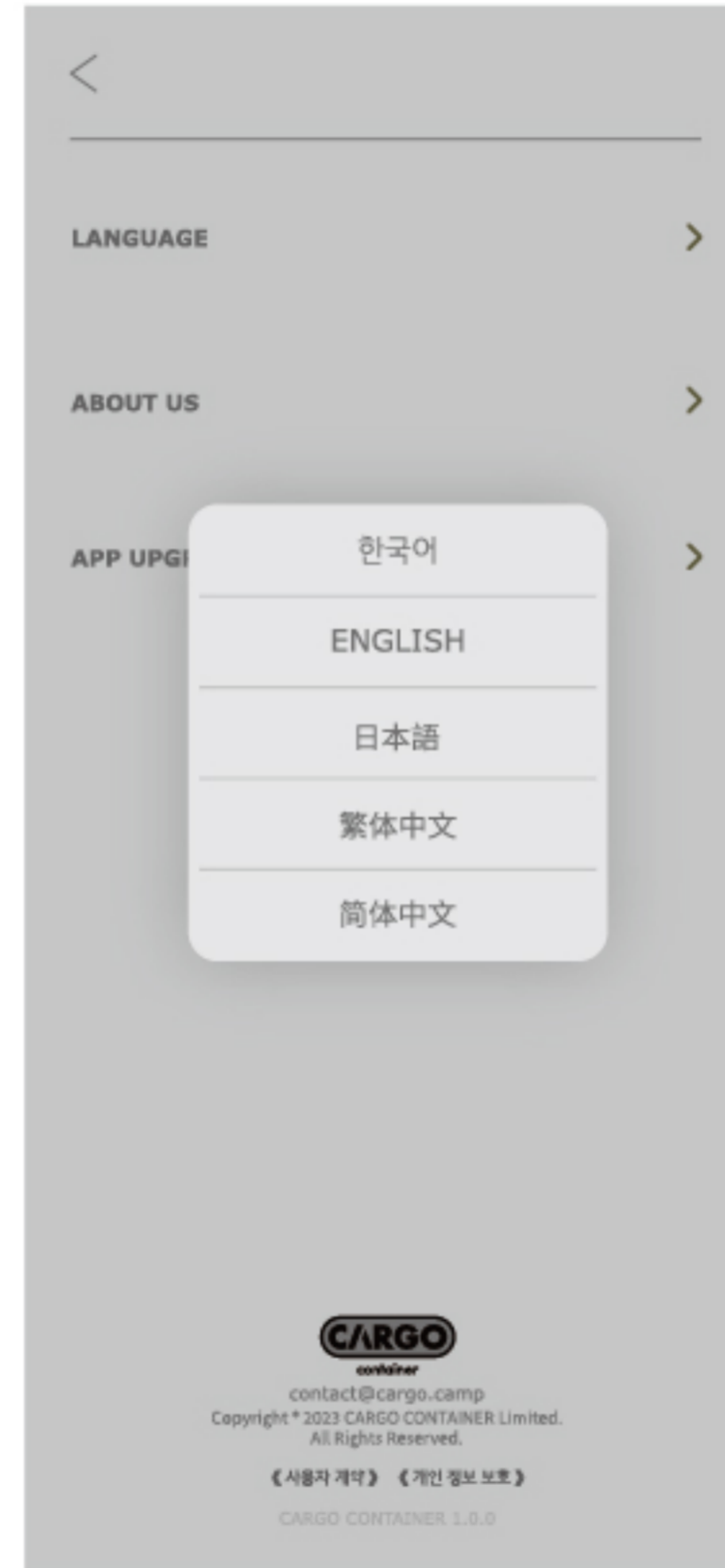

EN

## Bluetooth Pairing

- a** PRESS POWER BUTTON THREE TIMES.  
FIRST, PRESS POWER BUTTON TWO TIMES QUICKLY AND THE LAST THIRD TIME FOR THREE SECONDS.
- b** WHEN THE POWER BUTTON STARTS BLINKING, OPEN THE APPLICATION AND FOLLOW THE NEXT PAGES TO REGISTER THE DEVICE.

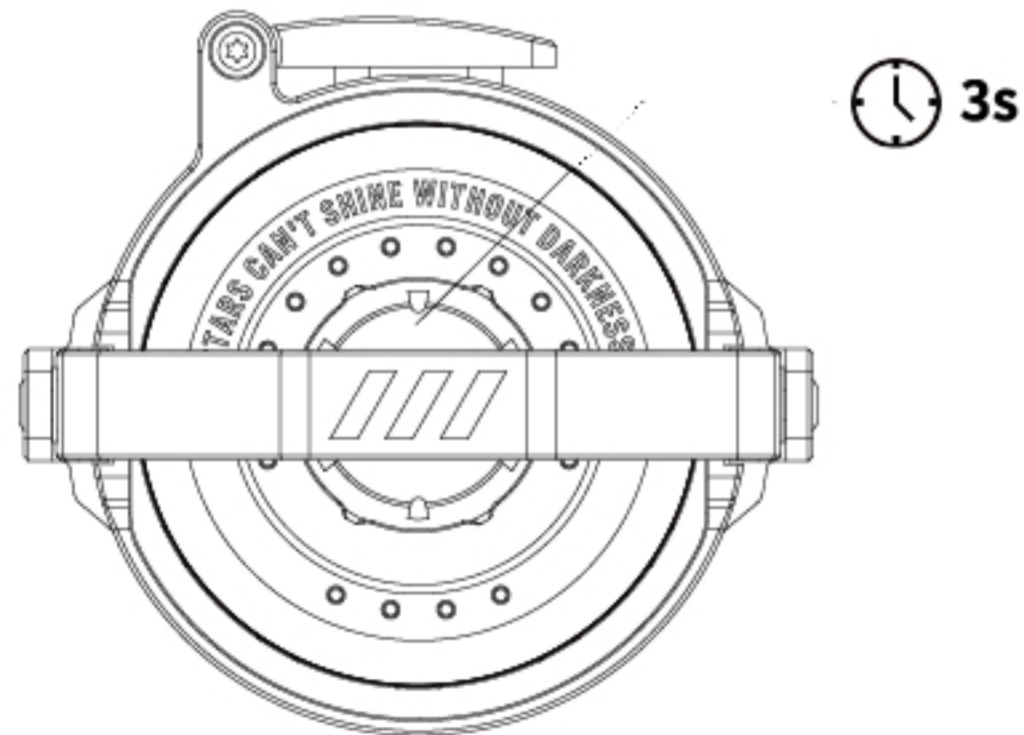

## HOW TO USE

EN

## Add New Product

- a** ON THE APP'S HOME SCREEN, TAP THE "ADD PRODUCT" BUTTON TO REGISTER A NEW PRODUCT.
- b** WHEN THE DEVICE SEARCH IS SUCCESSFUL, A LIST OF AVAILABLE PRODUCTS FOR REGISTRATION WILL BE DISPLAYED. SELECT THE PRODUCT YOU WANT TO CONNECT FROM THE LIST.

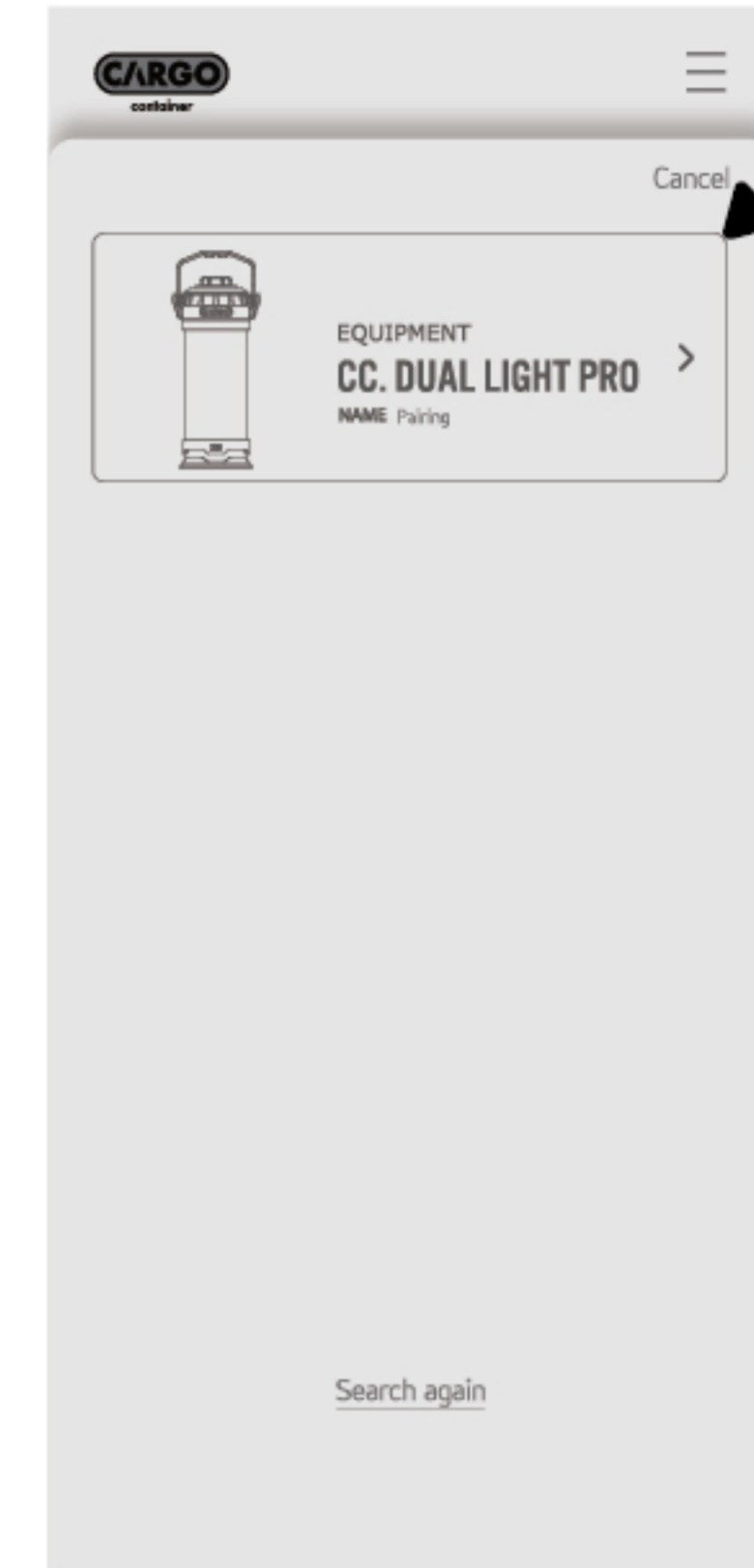

- c** ONCE THE DEVICE IS SUCCESSFULLY CONNECTED, YOU WILL BE TAKEN TO THE MAIN CONTROL SCREEN WHERE YOU CAN CONTROL THE DEVICE.

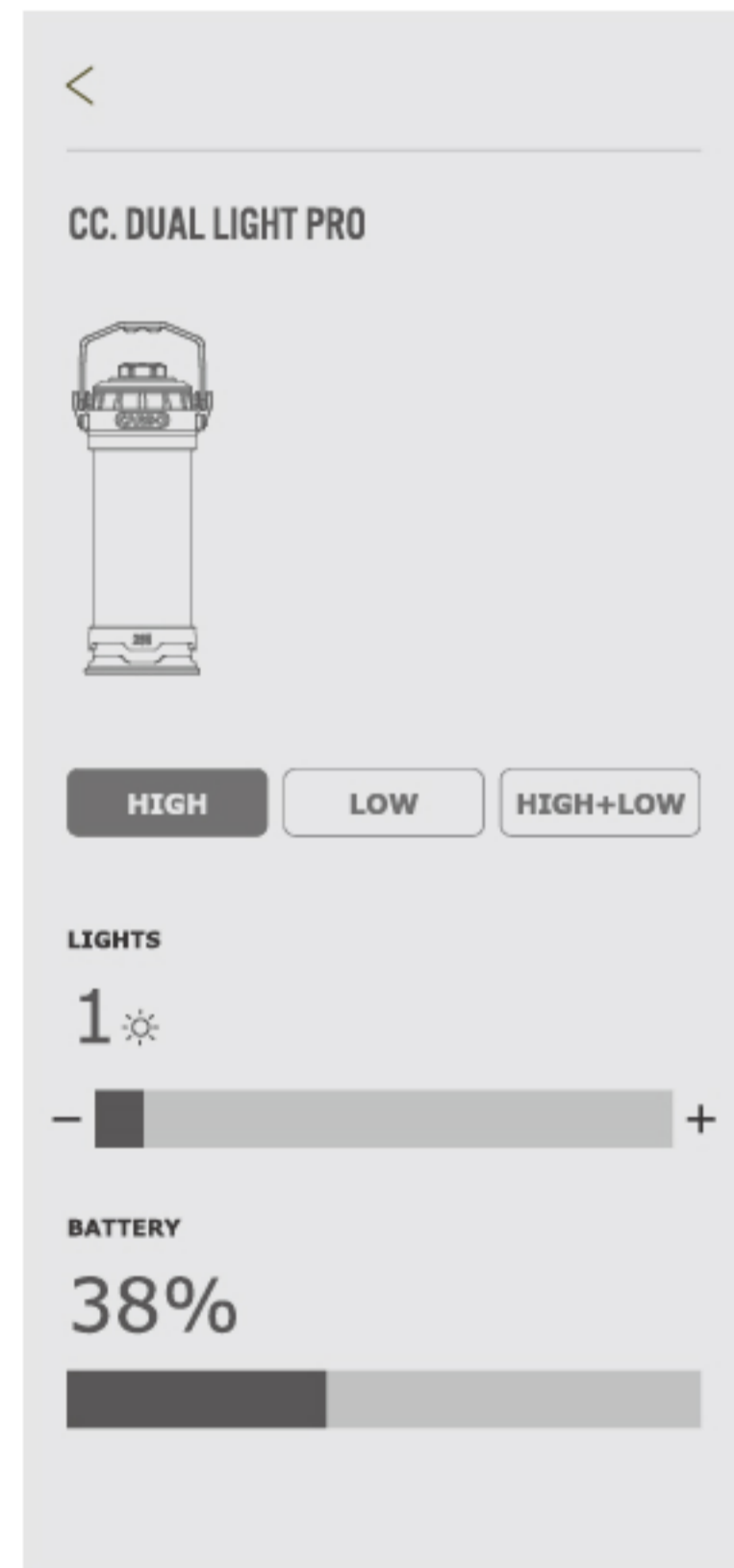

EN

## Main Control Screen

**a** REGISTERED PRODUCT DISPLAY

**b** MODE BUTTON

**c** BRIGHTNESS

**d** BATTERY INDICATOR



### **a** Registered Product Display

SHOWS THE CURRENTLY PAIRED PRODUCT.

### **b** Change mode

HIGH – LOW – HIGH + LOW MODE CAN BE SELECTED.

\* PRESS 2 TIMES TO TURN OFF THE POWER

### **c** Adjust brightness

DRAG THE CONTROL BAR WITH YOUR FINGER TO SET THE BRIGHTNESS TO STEPS 0 TO 12.

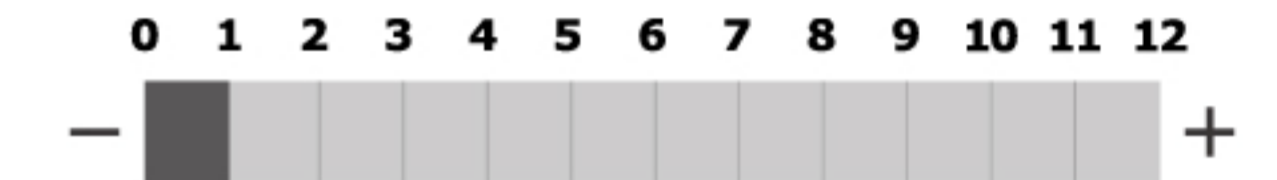

### **d** Battery Level Display

SHOWS THE REMAINING BATTERY LEVEL.

## Rename Product

**a** TO RENAME A PRODUCT IN THE REGISTERED PRODUCT LIST, LONG-PRESS THE PRODUCT YOU WANT TO RENAME.



**b** ON THE NEXT SCREEN, SELECT "RENAME" TO ACCESS THE RENAMING SCREEN.

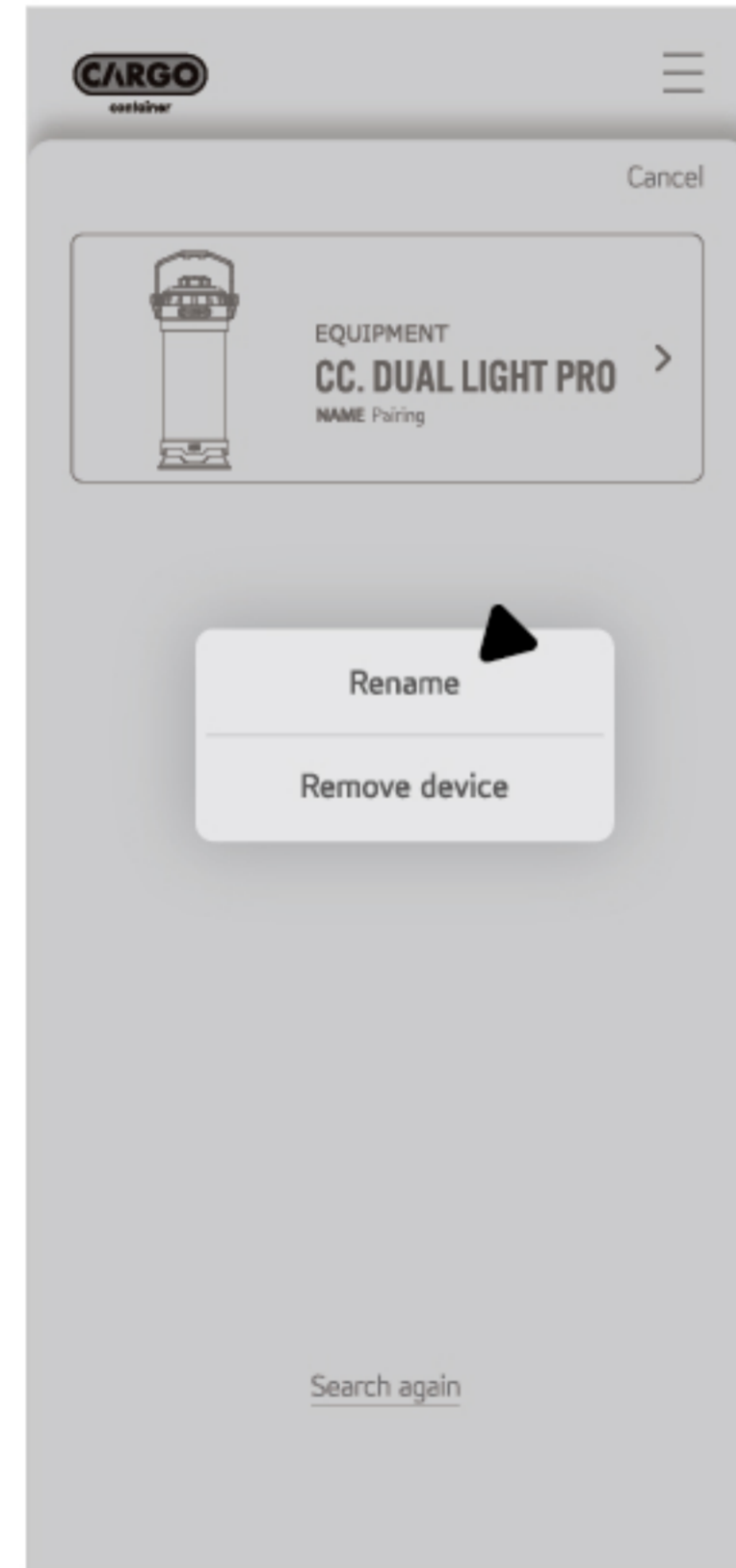

**c** ON THE RENAMING SCREEN, ENTER THE DESIRED PRODUCT NAME AND PRESS "SAVE" TO CHANGE THE REGISTERED NAME.

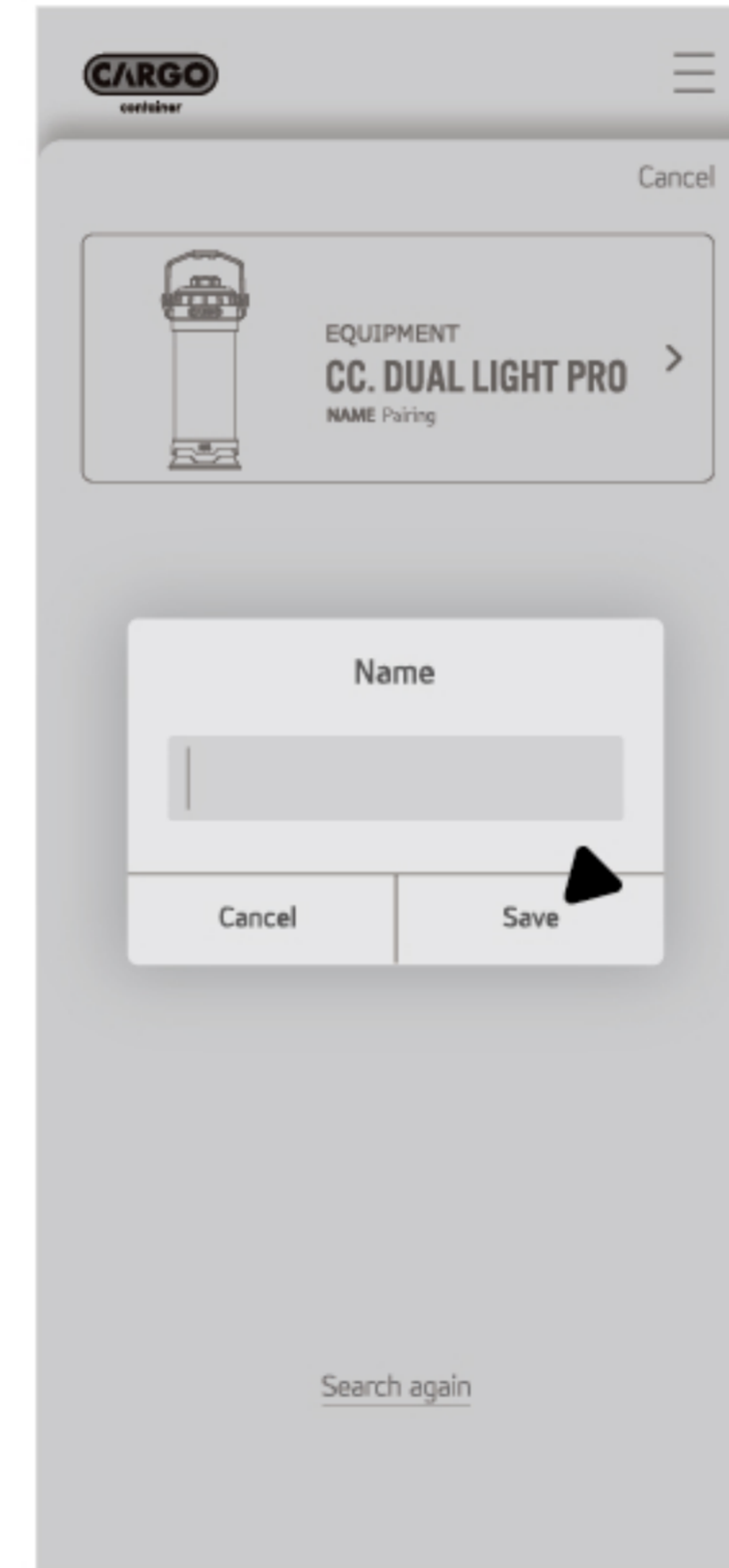

## Delete Device

**a** TO DELETE A DEVICE FROM THE REGISTERED PRODUCT LIST, LONG-PRESS THE PRODUCT YOU WANT TO DELETE.



**b** IF YOU WANT TO RE-REGISTER THE PRODUCT, PRESS THE "ADD PRODUCT" BUTTON ON THE APP'S HOME SCREEN TO REGISTER IT AGAIN.

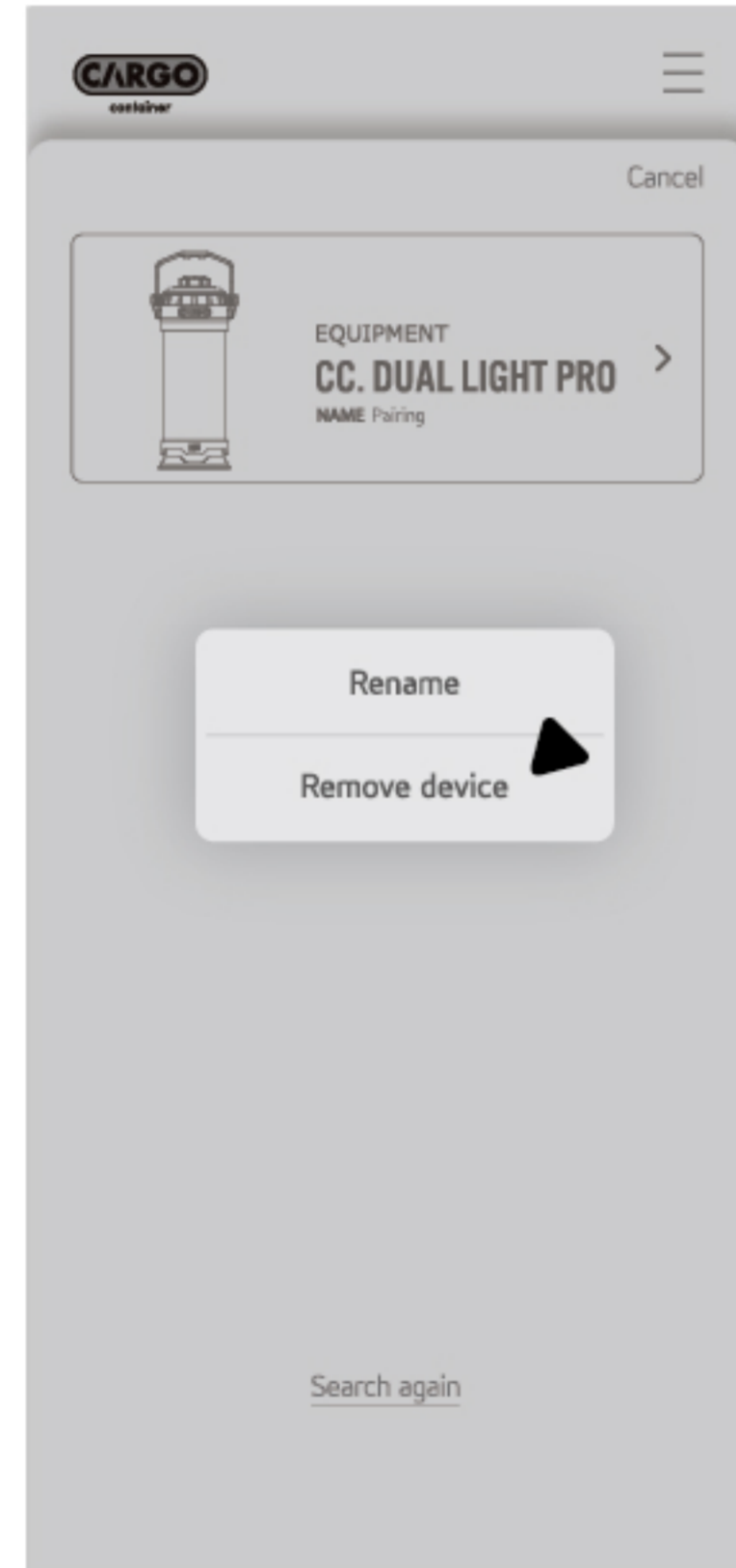

**c** IF YOU WANT TO RE-REGISTER THE PRODUCT, PRESS THE "ADD PRODUCT" BUTTON ON THE APP'S HOME SCREEN TO REGISTER IT AGAIN.



FCC Warning Statement: Changes or modifications to this unit not expressly approved by the party responsible for compliance could void the user's authority to operate the equipment. This equipment has been tested and found to comply with the limits for a Class B digital device, pursuant to Part 15 of the FCC Rules. These limits are designed to provide reasonable protection against harmful interference in a residential installation. This equipment generates, uses and can radiate radio frequency energy and, if not installed and used in accordance with the instructions, may cause harmful interference to radio communications.

However, there is no guarantee that interference will not occur in a particular installation. If this equipment does cause harmful interference to radio or television reception, which can be determined by turning the equipment off and on, the user is encouraged to try to correct the interference by one or more of the following measures:

- Reorient or relocate the receiving antenna.
- Increase the separation between the equipment and receiver.
- Connect the equipment into an outlet on a circuit different from that to which the receiver is connected.
- Consult the dealer or an experienced radio/TV technician for help.

This device complies with Part 15 of the FCC Rules. Operation is subject to the following two conditions: (1) this device may not cause harmful interference, and (2) this device must accept any interference received, including interference that may cause undesired operation.

#### FCC Radiation Exposure Statement

The device has been evaluated to meet general RF exposure requirement.

The device can be used in portable exposure condition without restriction.