

OFDMA with one active Resource Unit (worst case OFDMA):

Radio Technology = WLAN ax 20 MHz MIMO, Operating Frequency = low + high, Band Edge = low + high (S01_377_AE01)

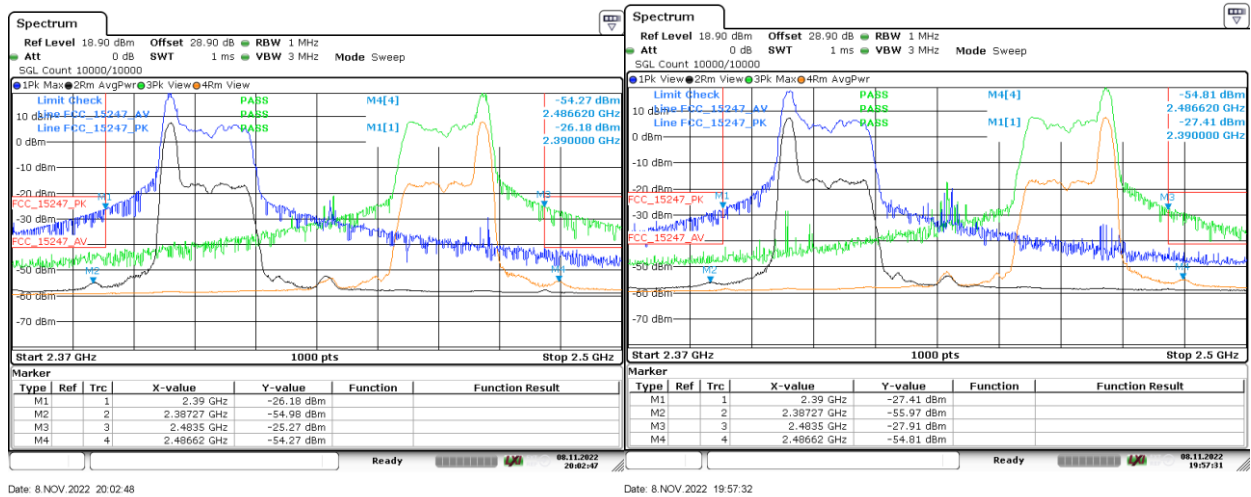

Antenna A

Power 9

Antenna B

Radio Technology = WLAN ax 40 MHz MIMO, Operating Frequency = low + high, Band Edge = low + high (S01_377_AE01)

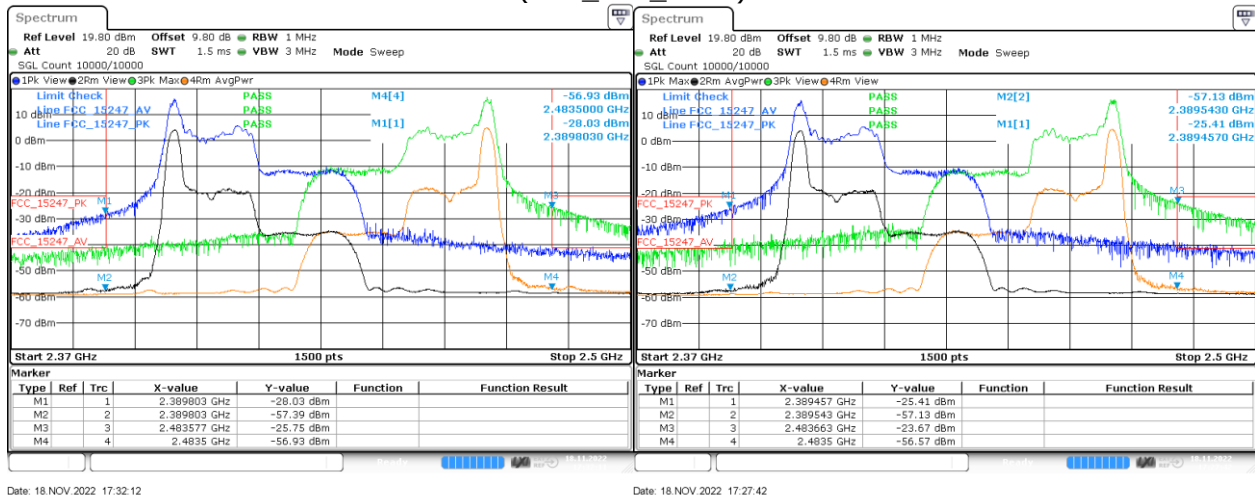

Antenna A

Power 6

Antenna B

5.8.5 TEST EQUIPMENT USED

- Radiated Emissions FAR 2.4 GHz FCC
- Radiated Emissions
- R&S TS8997

5.9 POWER DENSITY

Standard **FCC Part 15 Subpart C**

The test was performed according to:
ANSI C63.10

5.9.1 TEST DESCRIPTION

The Equipment Under Test (EUT) was set up in a shielded room to perform the Power Density measurements.

The results recorded were measured with the modulation which produces the worst-case (highest) power density.

The EUT was connected to the test system as described in the block diagram below. The complete attenuation of the measurement path is known and considered.

Maximum Peak Power Spectral Density (e.g. Bluetooth low energy):

Analyser settings:

- Resolution Bandwidth (RBW): 100 kHz, 10 kHz or 3 kHz
- Video Bandwidth (VBW): ≥ 3 times RBW
- Trace: Maxhold
- Sweeps: Till stable (min. 200, max. 15000)
- Sweeptime: Auto
- Detector: Peak

Maximum Average Power Spectral Density (e.g. WLAN):

Analyser settings:

- Resolution Bandwidth (RBW): 100 kHz, 10 kHz or 3 kHz
- Video Bandwidth (VBW): ≥ 3 times RBW
- Sweep Points: ≥ 2 times span / RBW
- Trace: Maxhold
- Sweeps: Till stable (max. 150)
- Sweeptime: \leq Number of Sweep Points x minimum transmission duration
- Detector: RMS

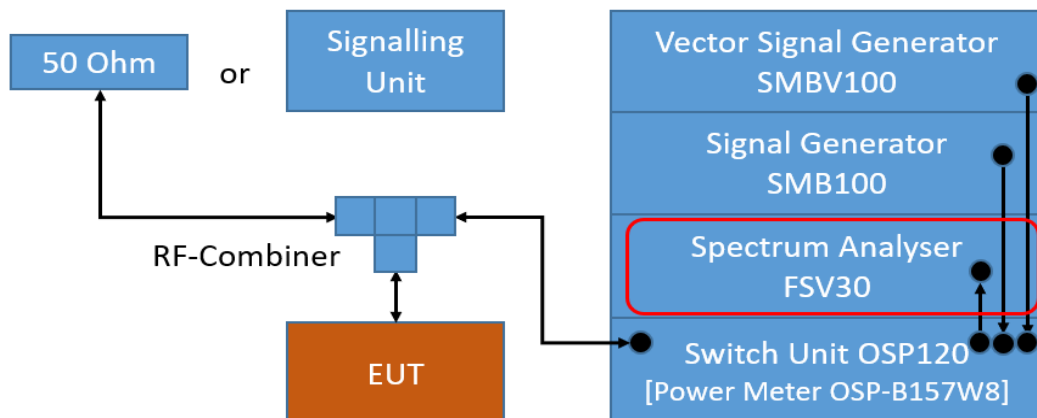

TS8997; Power Spectral Density

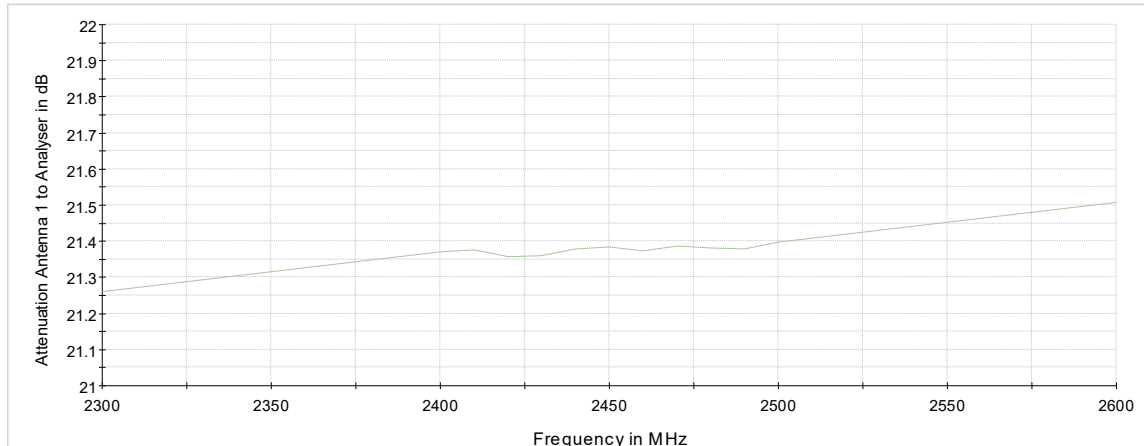

Attenuation of the measurement path

5.9.2 TEST REQUIREMENTS / LIMITS

FCC Part 15, Subpart C, §15.247 (e)

For digitally modulated systems, the peak power spectral density conducted from the intentional radiator to the antenna shall not be greater than 8 dBm in any 3 kHz band during any time interval of continuous transmission.

...

The same method of determining the conducted output power shall be used to determine the power spectral density.

FCC Part 15, Subpart C, §15.247 (f)

(f) For the purposes of this section, hybrid systems are those that employ a combination of both frequency hopping and digital modulation techniques.

...

The power spectral density conducted from the intentional radiator to the antenna due to the digital modulation operation of the hybrid system, with the frequency hopping operation turned off, shall not be greater than 8 dBm in any 3 kHz band during any time interval of continuous transmission

5.9.3 TEST PROTOCOL

Ambient temperature: 24 -26 °C
 Air Pressure: 1004 - 1026 hPa
 Humidity: 38 -40 %
 BT LE 1 Mbit/s

Variant	Ch. No.	Freq. [MHz]	Power Density [dBm / RBW]	RBW [kHz]	Limit [dBm/3kHz]	Margin to Limit [dB]
374	0	2402	-2.0	10.0	8.0	10.0
377	0	2402	-1.7	10.0	8.0	9.7
374	19	2440	-2.0	10.0	8.0	10.0
377	19	2440	-1.7	10.0	8.0	9.7
377	39	2480	-1.6	10.0	8.0	9.6
374	39	2480	-2.1	10.0	8.0	10.1

BT LE 2 Mbit/s

Variant	Channel No.	Frequency [MHz]	Power Density [dBm / RBW]	RBW [kHz]	Limit [dBm/3kHz]	Margin to Limit [dB]
377	0	2402	-5.0	10.0	8.0	13.0
374	0	2402	-5.3	10.0	8.0	13.3
377	19	2440	-5.0	10.0	8.0	13.0
374	19	2440	-5.3	10.0	8.0	13.3
374	39	2480	-5.5	10.0	8.0	13.5
377	39	2480	-5.0	10.0	8.0	13.0

BT GFSK (1-DH5)

Variant	Channel No.	Frequency [MHz]	Power Density [dBm / RBW]	RBW [kHz]	Limit [dBm/3kHz]	Margin to Limit [dB]
377	0	2402	5.6	10.0	8.0	2.4
377	39	2441	5.6	10.0	8.0	2.4
377	78	2480	5.5	10.0	8.0	2.5
374	0	2402	5.5	10.0	8.0	2.5
374	39	2441	5.5	10.0	8.0	2.5
374	78	2480	5.4	10.0	8.0	2.6

BT DQPSK (2-DH5)

Variant	Channel No.	Frequency [MHz]	Power Density [dBm / RBW]	RBW [kHz]	Limit [dBm/3kHz]	Margin to Limit [dB]
377	0	2402	2.0	10.0	8.0	6.0
377	39	2441	0.8	10.0	8.0	7.2
377	78	2480	0.8	10.0	8.0	7.2
374	0	2402	0.6	10.0	8.0	7.4
374	39	2441	0.7	10.0	8.0	7.3
374	78	2480	0.5	10.0	8.0	7.5

BT 8-DPSK (3-DH5)

Variant	Channel No.	Frequency [MHz]	Power Density [dBm / RBW]	RBW [kHz]	Limit [dBm/3kHz]	Margin to Limit [dB]
377	0	2402	0.5	10.0	8.0	7.5
377	39	2441	0.9	10.0	8.0	7.1
377	78	2480	0.6	10.0	8.0	7.4
374	0	2402	0.7	10.0	8.0	7.3
374	39	2441	0.5	10.0	8.0	7.5
374	78	2480	0.6	10.0	8.0	7.4

WLAN b-Mode; 20 MHz; 1 Mbit/s

Variant	Ch. No.	Freq. [MHz]	Power Density [dBm / RBW]	RBW [kHz]	Limit [dBm/3kHz]	Margin to Limit [dB]
377	1	2412	1.4	100.0	8.0	6.6
377	6	2437	3.3	100.0	8.0	4.7
377	11	2462	1.9	100.0	8.0	6.1

WLAN g-Mode; 20 MHz; 6 Mbit/s

Variant	Channel No.	Frequency [MHz]	Power Density [dBm / RBW]	RBW [kHz]	Limit [dBm/3kHz]	Margin to Limit [dB]
377	1	2412	-5.3	100.0	8.0	13.3
377	6	2437	-1.2	100.0	8.0	9.2
377	11	2462	-5.7	100.0	8.0	13.7

WLAN n-Mode; 20 MHz; MCS0

Variant	Channel No.	Frequency [MHz]	Power Density [dBm / RBW]	RBW [kHz]	Limit [dBm/3kHz]	Margin to Limit [dB]
377	1	2412	-5.7	100.0	8.0	13.7
377	6	2437	-3.0	100.0	8.0	11.0
377	11	2462	-6.2	100.0	8.0	14.2

WLAN n-Mode; 40 MHz; MCS0

Variant	Channel No.	Frequency [MHz]	Power Density [dBm / RBW]	RBW [kHz]	Limit [dBm/3kHz]	Margin to Limit [dB]
377	3	2422	-9.7	100.0	8.0	17.7
377	6	2437	-9.3	100.0	8.0	17.3
377	9	2452	-10.1	100.0	8.0	18.1

WLAN ax-Mode; 20 MHz; MCS0

Variant	Channel No.	Frequency [MHz]	Power Density [dBm / RBW]	RBW [kHz]	Limit [dBm/3kHz]	Margin to Limit [dB]
377	1	2412	-7.7	100.0	8.0	15.7
377	6	2437	-3.3	100.0	8.0	11.3
377	11	2462	-8.4	100.0	8.0	16.4

WLAN ax-Mode; 40 MHz; MCS0

Variant	Channel No.	Frequency [MHz]	Power Density [dBm / RBW]	RBW [kHz]	Limit [dBm/3kHz]	Margin to Limit [dB]
377	3	2422	-10.3	100.0	8.0	18.3
377	6	2437	-10.2	100.0	8.0	18.2
377	9	2452	-10.7	100.0	8.0	18.7

WLAN n-Mode; 20 MHz MIMO; MCS8

Variant	Channel No.	Frequency [MHz]	Power Density [dBm / RBW]	RBW [kHz]	Limit [dBm/3kHz]	Margin to Limit [dB]
377	1	2412	-3.5	100	8.0	11.5
377	6	2437	-1.1	100	8.0	9.1
377	11	2462	-4.3	100	8.0	12.3

WLAN n-Mode; 40 MHz MIMO; MCS8

Variant	Channel No.	Frequency [MHz]	Power Density [dBm / RBW]	RBW [kHz]	Limit [dBm/3kHz]	Margin to Limit [dB]
377	3	2422	-7.5	100	8.0	15.5
377	6	2437	-7.5	100	8.0	15.5
377	9	2452	-8.2	100	8.0	16.2

WLAN ax-Mode; 20 MHz; MCS0; MIMO

Variant	Ch. No.	Freq. [MHz]	Power Density [dBm / RBW]	RBW [kHz]	Limit [dBm/3kHz]	Margin to Limit [dB]
377	1	2412	-5.4	100	8.0	13.4
377	6	2437	-1.1	100	8.0	9.1
377	11	2462	-6.2	100	8.0	14.2

WLAN ax-Mode; 40 MHz; MCS0; MIMO

Variant	Ch. No.	Freq. [MHz]	Power Density [dBm / RBW]	RBW [kHz]	Limit [dBm/3kHz]	Margin to Limit [dB]
377	3	2422	-8.2	100	8.0	16.2
377	6	2437	-8.1	100	8.0	16.1
377	9	2452	-9.1	100	8.0	17.1

Remark: Please see next sub-clause for the measurement plot.
 WLAN SISO results of antenna A given in table above.

OFDMA with one active Resource Unit (worst case OFDMA):

WLAN ax-Mode; 20 MHz; MCS0; MIMO; RU 5

Variant	Ch. No.	Freq. [MHz]	Power Density [dBm / RBW]	RBW [kHz]	Limit [dBm/ 3kHz]	Margin to Limit [dB]
377	1	2412	0.5	100	8.0	7.5
377	6	2437	0.6	100	8.0	7.4
377	11	2462	0.8	100	8.0	7.2

WLAN ax-Mode; 40 MHz; MCS0; MIMO; RU 6

Variant	Ch. No.	Freq. [MHz]	Power Density [dBm / RBW]	RBW [kHz]	Limit [dBm/ 3kHz]	Margin to Limit [dB]
377	3	2422	0.6	100	8.0	7.4
377	6	2437	0.8	100	8.0	7.2
377	9	2452	0.7	100	8.0	7.3

Remark: Please see next sub-clause for the measurement plot.

Measurement was performed with active RU unit 5 (20 MHz BW) and 6 (40 MHz BW), which proved worst case in preliminary measurement.

WLAN ax 40 MHz tested at 9 dBm and not repeated for final setting of 6 dBm, since it is worse case.

5.9.4 MEASUREMENT PLOT (EXAMPLE PLOT, SHOWING WORST CASE, IF APPLICABLE)

Radio Technology = WLAN n 20 MHz MIMO, Operating Frequency = mid (S01_377_AA01)

DUT Frequency (MHz)	Frequency (MHz)	PSD (dBm)	Limit Max (dBm)	Result
2437.000000	2439.525000	-1.299	8.0	PASS

Ports

Port	State
1	used
2	used

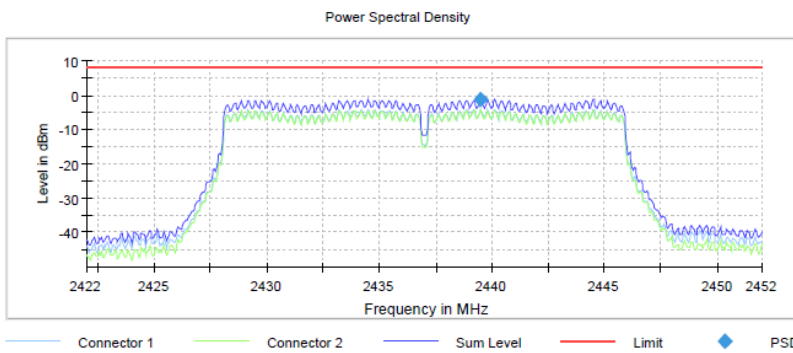

Setting	Instrument Value
Start Frequency	2.42200 GHz
Stop Frequency	2.45200 GHz
Span	30.000 MHz
RBW	100.000 kHz
VBW	300.000 kHz
SweepPoints	600
SweepTime	600.000 ms
Reference Level	0.000 dBm
Attenuation	10.000 dB
Detector	RMS
SweepCount	1
Filter	3 dB
Trace Mode	Max Hold
SweepType	Sweep
Preamp	off
Stablemode	Trace
Stablevalue	0.50 dB
Run	9 / max. 150
Stable	3 / 3
Max Stable Difference	0.34 dB

Radio Technology = Bluetooth LE 1 Mbps, Operating Frequency = low (S01_374_BA01)

DUT Frequency (MHz)	Frequency (MHz)	PSD (dBm)	Limit Max (dBm)	Result
2402.000000	2401.977500	-1.958	8.0	PASS

Ports

Port	State
1	used

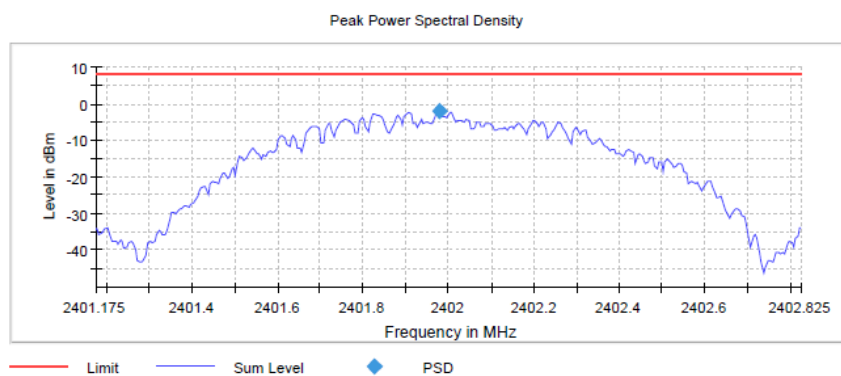

Setting	Instrument Value
Start Frequency	2.40118 GHz
Stop Frequency	2.40283 GHz
Span	1.650 MHz
RBW	10.000 kHz
VBW	30.000 kHz
SweepPoints	330
SweepTime	1.650 ms
Reference Level	-10.000 dBm
Attenuation	0.000 dB
Detector	MaxPeak
SweepCount	100
Filter	3 dB
Trace Mode	Max Hold
SweepType	Sweep
Preamp	off
Stablemode	Trace
Stablevalue	0.50 dB
Run	3 / max. 150
Stable	2 / 2
Max Stable Difference	0.11 dB

Radio Technology = Bluetooth LE 1 Mbps, Operating Frequency = low
(S01_377_AA01)

Result

DUT Frequency (MHz)	Frequency (MHz)	PSD (dBm)	Limit Max (dBm)	Result
2402.000000	2401.962500	-1.656	8.0	PASS

Ports

Port	State
1	used

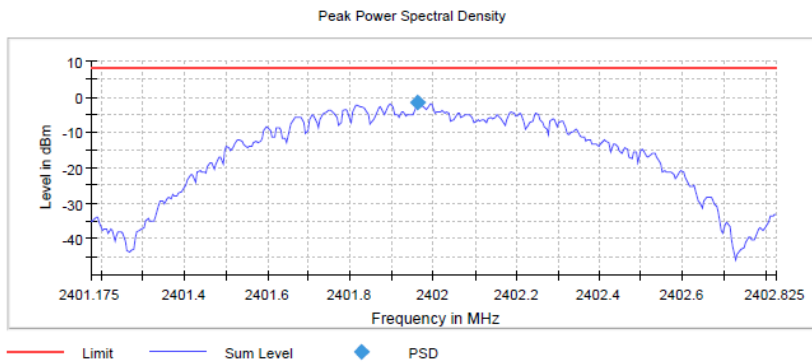

Setting	Instrument Value
Start Frequency	2.40118 GHz
Stop Frequency	2.40283 GHz
Span	1.650 MHz
RBW	10.000 kHz
VBW	30.000 kHz
SweepPoints	330
SweepTime	1.650 ms
Reference Level	-10.000 dBm
Attenuation	0.000 dB
Detector	MaxPeak
SweepCount	100
Filter	3 dB
Trace Mode	Max Hold
SweepType	Sweep
Preamp	off
Stablemode	Trace
Stablevalue	0.50 dB
Run	4 / max. 150
Stable	2 / 2
Max Stable Difference	0.08 dB

Radio Technology = Bluetooth BDR, Operating Frequency = low
(S01_377_AA01)

Result

DUT Frequency (MHz)	Frequency (MHz)	PSD (dBm)	Limit Max (dBm)	Result
2402.000000	2402.067500	5.573	8.0	PASS

Ports

Port	State
1	used

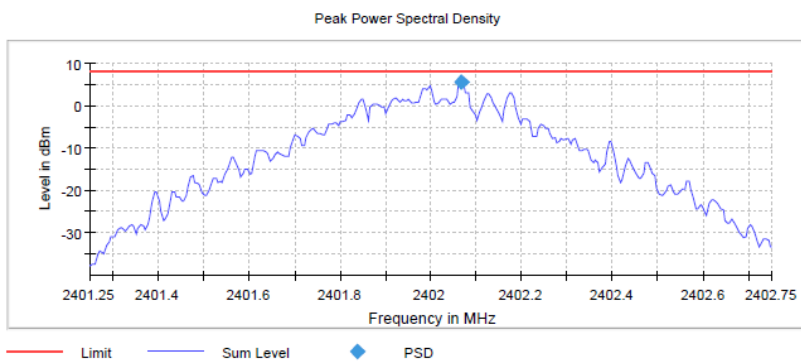

Setting	Instrument Value
Start Frequency	2.40125 GHz
Stop Frequency	2.40275 GHz
Span	1.500 MHz
RBW	10.000 kHz
VBW	30.000 kHz
SweepPoints	300
SweepTime	1.500 ms
Reference Level	0.000 dBm
Attenuation	10.000 dB
Detector	MaxPeak
SweepCount	100
Filter	3 dB
Trace Mode	Max Hold
SweepType	Sweep
Preamp	off
Stablemode	Trace
Stablevalue	0.50 dB
Run	9 / max. 150
Stable	2 / 2
Max Stable Difference	0.08 dB

Radio Technology = Bluetooth EDR2, Operating Frequency = low
(S01_377_AA01)

Result

DUT Frequency (MHz)	Frequency (MHz)	PSD (dBm)	Limit Max (dBm)	Result
2402.000000	2402.172500	2.032	8.0	PASS

Ports

Port	State
1	used

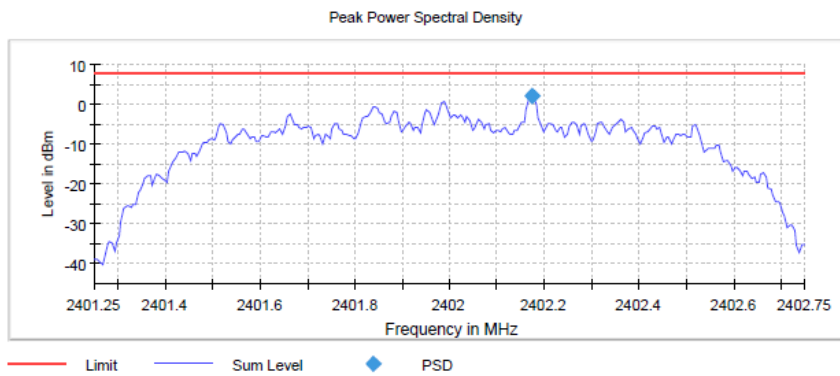

Setting	Instrument Value
Start Frequency	2.40125 GHz
Stop Frequency	2.40275 GHz
Span	1.500 MHz
RBW	10.000 kHz
VBW	30.000 kHz
SweepPoints	300
SweepTime	1.500 ms
Reference Level	0.000 dBm
Attenuation	10.000 dB
Detector	MaxPeak
SweepCount	100
Filter	3 dB
Trace Mode	Max Hold
SweepType	Sweep
Preamp	off
Stablemode	Trace
Stablevalue	0.50 dB
Run	6 / max. 150
Stable	2 / 2
Max Stable Difference	0.22 dB

Radio Technology = EDR3, Operating Frequency = mid
(S01_377_AA01)

Result

DUT Frequency (MHz)	Frequency (MHz)	PSD (dBm)	Limit Max (dBm)	Result
2441.000000	2440.987500	0.858	8.0	PASS

Ports

Port	State
1	used

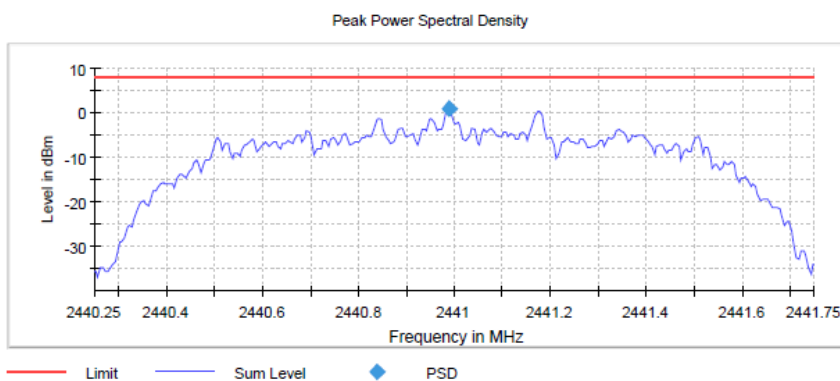

Setting	Instrument Value
Start Frequency	2.44025 GHz
Stop Frequency	2.44175 GHz
Span	1.500 MHz
RBW	10.000 kHz
VBW	30.000 kHz
SweepPoints	300
SweepTime	1.500 ms
Reference Level	0.000 dBm
Attenuation	10.000 dB
Detector	MaxPeak
SweepCount	100
Filter	3 dB
Trace Mode	Max Hold
SweepType	Sweep
Preamp	off
Stablemode	Trace
Stablevalue	0.50 dB
Run	7 / max. 150
Stable	2 / 2
Max Stable Difference	0.38 dB

Radio Technology = Bluetooth LE 2 Mbps, Operating Frequency = low
(S01_377_AA01)

Result

DUT Frequency (MHz)	Frequency (MHz)	PSD (dBm)	Limit Max (dBm)	Result
2402.000000	2401.967500	-5.006	8.0	PASS

Ports

Port	State
1	used

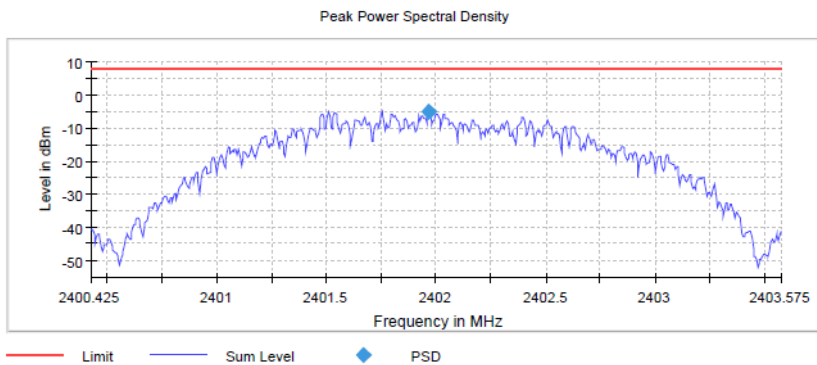

Setting	Instrument Value
Start Frequency	2.40043 GHz
Stop Frequency	2.40358 GHz
Span	3.150 MHz
RBW	10.000 kHz
VBW	30.000 kHz
SweepPoints	630
SweepTime	3.150 ms
Reference Level	-10.000 dBm
Attenuation	0.000 dB
Detector	MaxPeak
SweepCount	100
Filter	3 dB
Trace Mode	Max Hold
SweepType	Sweep
Preamp	off
Stablemode	Trace
Stablevalue	0.50 dB
Run	4 / max. 150
Stable	2 / 2
Max Stable Difference	0.15 dB

Radio Technology = Bluetooth LE 2 Mbps, Operating Frequency = low
(S01_374_BA01)

DUT Frequency (MHz)	Frequency (MHz)	PSD (dBm)	Limit Max (dBm)	Result
2402.000000	2401.507500	-5.324	8.0	PASS

Ports

Port	State
1	used

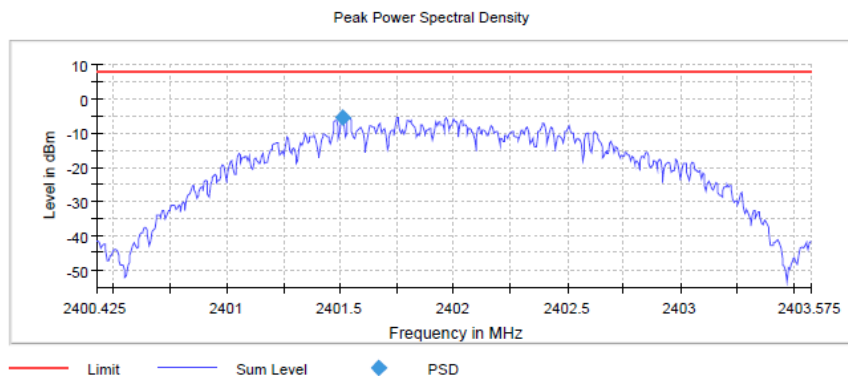

Setting	Instrument Value
Start Frequency	2.40043 GHz
Stop Frequency	2.40358 GHz
Span	3.150 MHz
RBW	10.000 kHz
VBW	30.000 kHz
SweepPoints	630
SweepTime	3.150 ms
Reference Level	-10.000 dBm
Attenuation	0.000 dB
Detector	MaxPeak
SweepCount	100
Filter	3 dB
Trace Mode	Max Hold
SweepType	Sweep
Preamp	off
Stablemode	Trace
Stablevalue	0.50 dB
Run	4 / max. 150
Stable	2 / 2
Max Stable Difference	0.16 dB

Radio Technology = WLAN n 40 MHz MIMO, Operating Frequency = mid (S01_377_AA01)

DUT Frequency (MHz)	Frequency (MHz)	PSD (dBm)	Limit Max (dBm)	Result
2437.000000	2451.975000	-7.493	8.0	PASS

Ports

Port	State
1	used
2	used

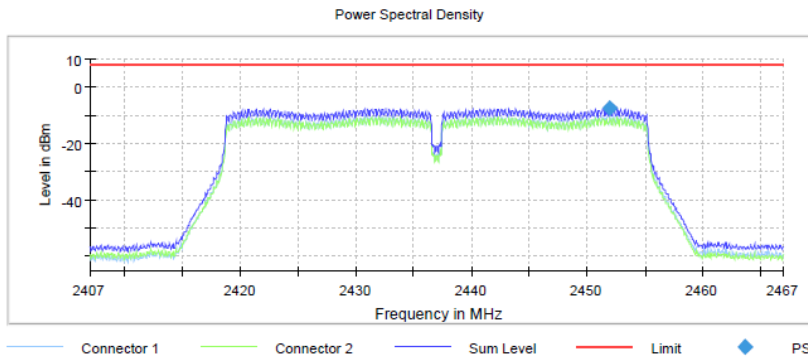

Setting	Instrument Value
Start Frequency	2.40700 GHz
Stop Frequency	2.46700 GHz
Span	60.000 MHz
RBW	100.000 kHz
VBW	300.000 kHz
SweepPoints	1200
SweepTime	1.200 s
Reference Level	0.000 dBm
Attenuation	10.000 dB
Detector	RMS
SweepCount	1
Filter	3 dB
Trace Mode	Max Hold
SweepType	Sweep
Preamp	off
Stablemode	Trace
Stablevalue	0.50 dB
Run	19 / max. 150
Stable	3 / 3
Max Stable Difference	0.47 dB

Radio Technology = WLAN b, Operating Frequency = mid (S01_377_AA01)

Result

DUT Frequency (MHz)	Frequency (MHz)	PSD (dBm)	Limit Max (dBm)	Result
2437.000000	2435.525000	3.335	8.0	PASS

Ports

Port	State
1	used

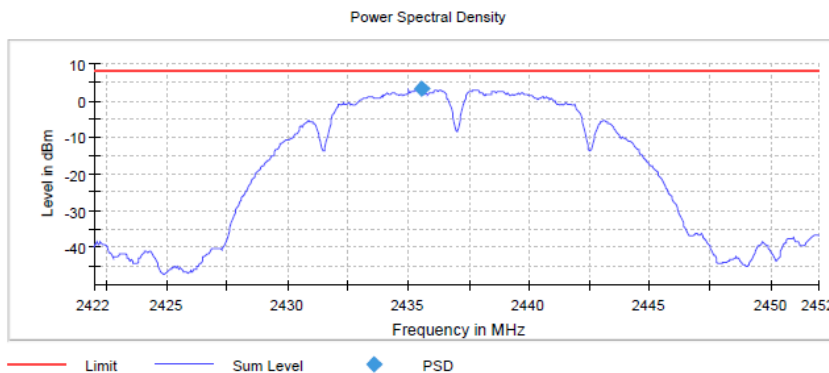

Setting	Instrument Value
Start Frequency	2.42200 GHz
Stop Frequency	2.45200 GHz
Span	30.000 MHz
RBW	100.000 kHz
VBW	300.000 kHz
SweepPoints	600
SweepTime	600.000 ms
Reference Level	10.000 dBm
Attenuation	20.000 dB
Detector	RMS
SweepCount	1
Filter	3 dB
Trace Mode	Max Hold
SweepType	Sweep
Preamp	off
Stablemode	Trace
Stablevalue	0.50 dB
Run	11 / max. 150
Stable	3 / 3
Max Stable Difference	0.30 dB

Radio Technology = WLAN ax 20 MHz MIMO, Operating Frequency = mid (S01_377_AA01)

DUT Frequency (MHz)	Frequency (MHz)	PSD (dBm)	Limit Max (dBm)	Result
2437.000000	2439.475000	-1.122	8.0	PASS

Ports

Port	State
1	used
2	used

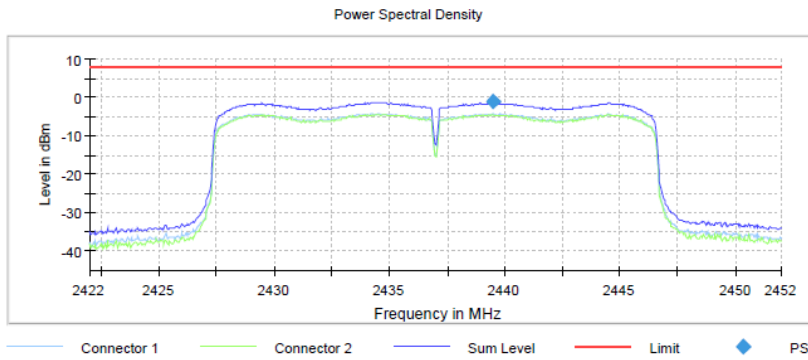

Setting	Instrument Value
Start Frequency	2.42200 GHz
Stop Frequency	2.45200 GHz
Span	30.000 MHz
RBW	100.000 kHz
VBW	300.000 kHz
SweepPoints	600
SweepTime	600.000 ms
Reference Level	0.000 dBm
Attenuation	10.000 dB
Detector	RMS
SweepCount	1
Filter	3 dB
Trace Mode	Max Hold
SweepType	Sweep
Preamp	off
Stablemode	Trace
Stablevalue	0.50 dB
Run	7 / max. 150
Stable	3 / 3
Max Stable Difference	0.46 dB

Radio Technology = WLAN ax 40 MHz MIMO, Operating Frequency = mid (S01_377_AA01)

DUT Frequency (MHz)	Frequency (MHz)	PSD (dBm)	Limit Max (dBm)	Result
2437.000000	2441.975000	-8.150	8.0	PASS

Ports

Port	State
1	used
2	used

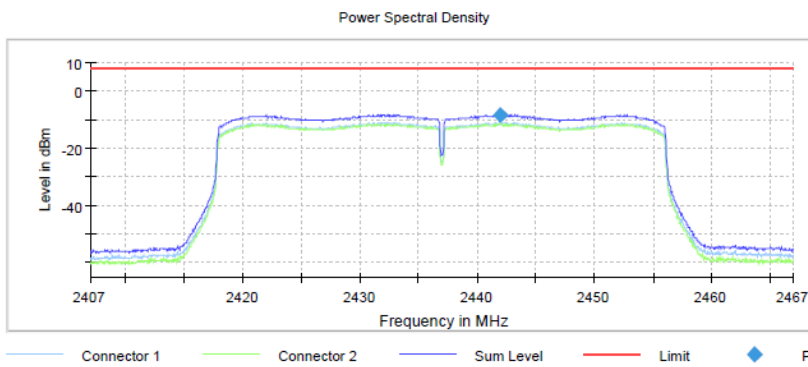

Setting	Instrument Value
Start Frequency	2.40700 GHz
Stop Frequency	2.46700 GHz
Span	60.000 MHz
RBW	100.000 kHz
VBW	300.000 kHz
SweepPoints	1200
SweepTime	1.200 s
Reference Level	0.000 dBm
Attenuation	10.000 dB
Detector	RMS
SweepCount	1
Filter	3 dB
Trace Mode	Max Hold
SweepType	Sweep
Preamp	off
Stablemode	Trace
Stablevalue	0.50 dB
Run	8 / max. 150
Stable	3 / 3
Max Stable Difference	0.41 dB

Radio Technology = WLAN g, Operating Frequency = mid
(S01_377_AA01)

DUT Frequency (MHz)	Frequency (MHz)	PSD (dBm)	Limit Max (dBm)	Result
2437.000000	2433.875000	-1.219	8.0	PASS

Ports

Port	State
1	used

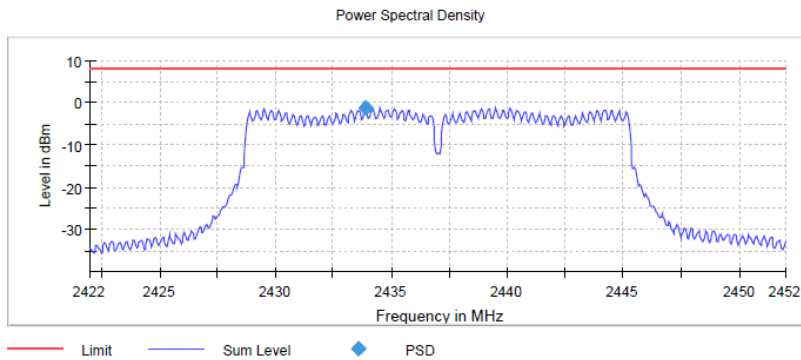

Setting	Instrument Value
Start Frequency	2.42200 GHz
Stop Frequency	2.45200 GHz
Span	30.000 MHz
RBW	100.000 kHz
VBW	300.000 kHz
SweepPoints	600
SweepTime	600.000 ms
Reference Level	0.000 dBm
Attenuation	10.000 dB
Detector	RMS
SweepCount	1
Filter	3 dB
Trace Mode	Max Hold
SweepType	Sweep
Preamp	off
Stablemode	Trace
Stablevalue	0.50 dB
Run	7 / max. 150
Stable	3 / 3
Max Stable Difference	0.47 dB

Radio Technology = WLAN n 20 MHz, Operating Frequency = mid
(S01_377_AA01)

DUT Frequency (MHz)	Frequency (MHz)	PSD (dBm)	Limit Max (dBm)	Result
2437.000000	2439.525000	-3.015	8.0	PASS

Ports

Port	State
1	used

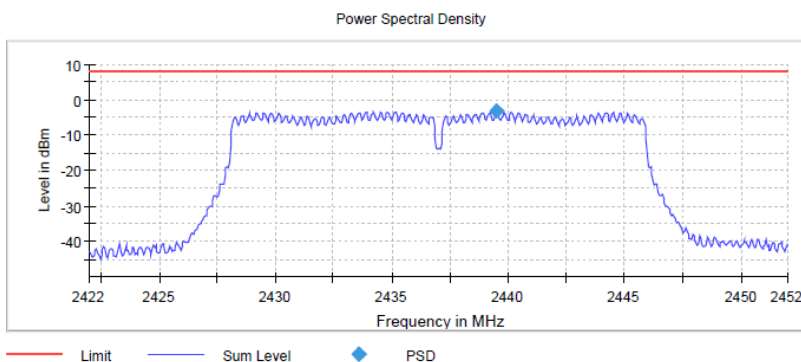

Setting	Instrument Value
Start Frequency	2.42200 GHz
Stop Frequency	2.45200 GHz
Span	30.000 MHz
RBW	100.000 kHz
VBW	300.000 kHz
SweepPoints	600
SweepTime	600.000 ms
Reference Level	0.000 dBm
Attenuation	10.000 dB
Detector	RMS
SweepCount	1
Filter	3 dB
Trace Mode	Max Hold
SweepType	Sweep
Preamp	off
Stablemode	Trace
Stablevalue	0.50 dB
Run	10 / max. 150
Stable	3 / 3
Max Stable Difference	0.18 dB

Radio Technology = WLAN n 40 MHz, Operating Frequency = mid (S01_377_AA01)

DUT Frequency (MHz)	Frequency (MHz)	PSD (dBm)	Limit Max (dBm)	Result
2437.000000	2452.025000	-9.273	8.0	PASS

Ports

Port	State
1	used

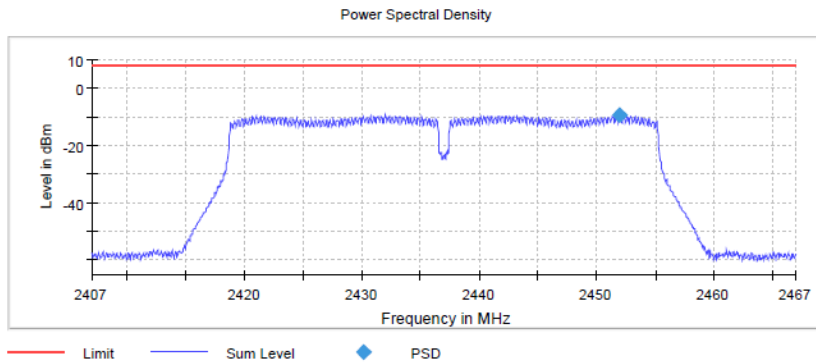

Setting	Instrument Value
Start Frequency	2.40700 GHz
Stop Frequency	2.46700 GHz
Span	60.000 MHz
RBW	100.000 kHz
VBW	300.000 kHz
SweepPoints	1200
Sweeptime	1.200 s
Reference Level	0.000 dBm
Attenuation	10.000 dB
Detector	RMS
SweepCount	1
Filter	3 dB
Trace Mode	Max Hold
Sweeptype	Sweep
Preamp	off
Stablemode	Trace
Stablevalue	0.50 dB
Run	21 / max. 150
Stable	3 / 3
Max Stable Difference	0.45 dB

Radio Technology = WLAN ax 20 MHz, Operating Frequency = mid (S01_377_AA01)

DUT Frequency (MHz)	Frequency (MHz)	PSD (dBm)	Limit Max (dBm)	Result
2437.000000	2434.425000	-3.330	8.0	PASS

Ports

Port	State
1	used

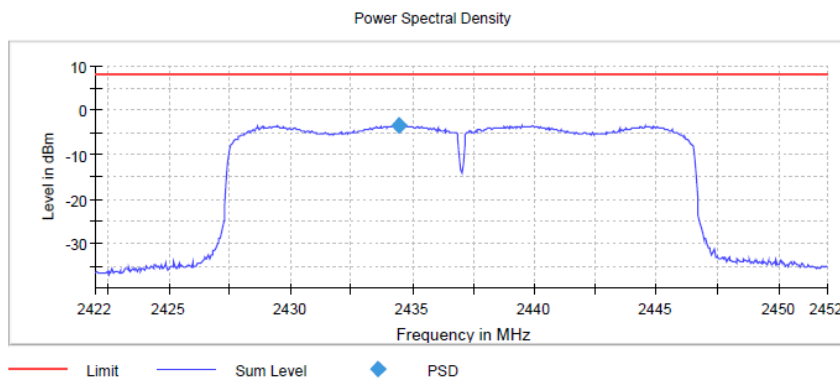

Setting	Instrument Value
Start Frequency	2.42200 GHz
Stop Frequency	2.45200 GHz
Span	30.000 MHz
RBW	100.000 kHz
VBW	300.000 kHz
SweepPoints	600
Sweeptime	600.000 ms
Reference Level	0.000 dBm
Attenuation	10.000 dB
Detector	RMS
SweepCount	1
Filter	3 dB
Trace Mode	Max Hold
Sweeptype	Sweep
Preamp	off
Stablemode	Trace
Stablevalue	0.50 dB
Run	9 / max. 150
Stable	3 / 3
Max Stable Difference	0.38 dB

Radio Technology = WLAN ax 40 MHz, Operating Frequency = mid (S01_377_AA01)

DUT Frequency (MHz)	Frequency (MHz)	PSD (dBm)	Limit Max (dBm)	Result
2437.000000	2452.025000	-10.212	8.0	PASS

Ports

Port	State
1	used

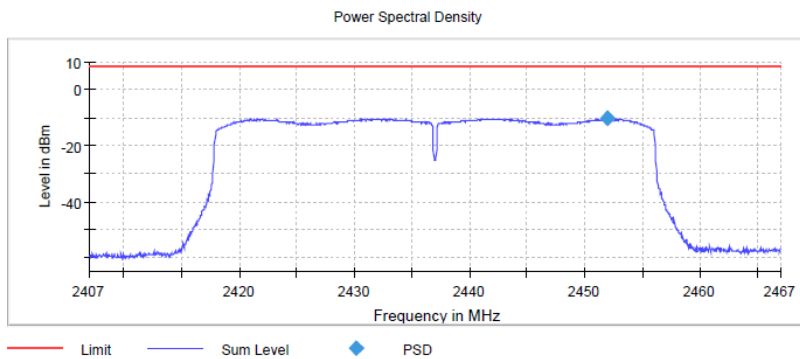

Setting	Instrument Value
Start Frequency	2.40700 GHz
Stop Frequency	2.46700 GHz
Span	60.000 MHz
RBW	100.000 kHz
VBW	300.000 kHz
SweepPoints	1200
SweepTime	1.200 s
Reference Level	0.000 dBm
Attenuation	10.000 dB
Detector	RMS
SweepCount	1
Filter	3 dB
Trace Mode	Max Hold
SweepType	Sweep
Preamp	off
Stablemode	Trace
Stablevalue	0.50 dB
Run	9 / max. 150
Stable	3 / 3
Max Stable Difference	0.42 dB

OFDMA with one active Resource Unit (worst case OFDMA):

Radio Technology = WLAN ax 20 MHz MIMO, Operating Frequency = high (S01_377_AE01)

DUT Frequency (MHz)	Frequency (MHz)	PSD (dBm)	Limit Max (dBm)	Result
2462.000000	2464.225000	0.802	8.0	PASS

Ports

Port	State
1	used
2	used

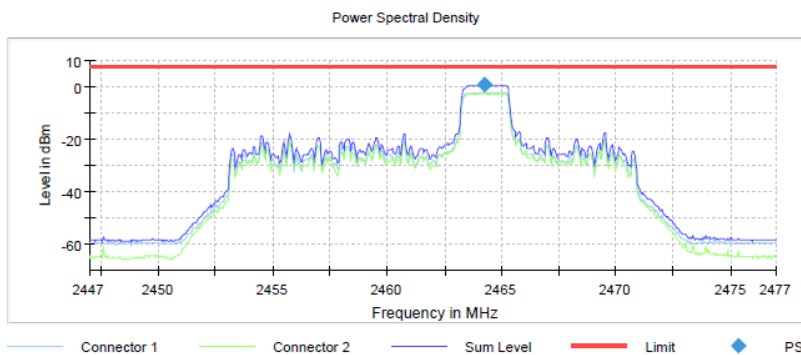

Setting	Instrument Value
Start Frequency	2.44700 GHz
Stop Frequency	2.47700 GHz
Span	30.000 MHz
RBW	100.000 kHz
VBW	300.000 kHz
SweepPoints	600
SweepTime	600.000 ms
Reference Level	10.000 dBm
Attenuation	20.000 dB
Detector	RMS
SweepCount	1
Filter	3 dB
Trace Mode	Max Hold
SweepType	Sweep
Preamp	off
Stablemode	Trace
Stablevalue	0.50 dB
Run	11 / max. 150
Stable	3 / 3
Max Stable Difference	0.39 dB

Radio Technology = WLAN ax 40 MHz MIMO, Operating Frequency = mid (S01_377_AE01)

DUT Frequency (MHz)	Frequency (MHz)	PSD (dBm)	Limit Max (dBm)	Result
2437.000000	2432.275000	0.821	8.0	PASS

Ports

Port	State
1	used
2	used

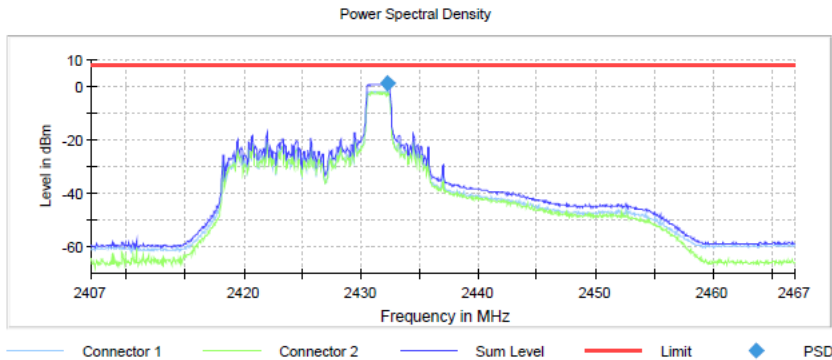

Setting	Instrument Value
Start Frequency	2.40700 GHz
Stop Frequency	2.46700 GHz
Span	60.000 MHz
RBW	100.000 kHz
VBW	300.000 kHz
SweepPoints	1200
SweepTime	1.200 s
Reference Level	10.000 dBm
Attenuation	20.000 dB
Detector	RMS
SweepCount	1
Filter	3 dB
Trace Mode	Max Hold
SweepType	Sweep
Preamplifier	off
Stablemode	Trace
Stablevalue	0.50 dB
Run	11 / max. 150
Stable	3 / 3
Max Stable Difference	0.49 dB

5.9.5 TEST EQUIPMENT USED

- R&S TS8997

6 TEST EQUIPMENT

- 1 Conducted Emissions FCC
Conducted Emissions AC Mains for FCC standards

Ref.No.	Device Name	Description	Manufacturer	Serial Number	Last Calibration	Calibration Due
1.1	MFS	Rubidium Frequency Normal MFS	Datum GmbH	002	2021-11	2022-11
1.2	Opus10 TPR (8253.00)	T/P Logger 13	Lufft Mess- und Regeltechnik GmbH	13936	2021-10	2023-10
1.3	Chroma 6404	AC Source	Chroma ATE INC.	64040001304		
1.4	Shielded Room 02	Shielded Room 4m x 3m	Frankonia Germany EMC Solution GmbH	-		
1.5	ESH3-Z5	Two-Line V-Network (EUT)	Rohde & Schwarz GmbH & Co. KG	829996/002	2021-08	2023-08
1.6	ESR 7	EMI Receiver / Spectrum Analyzer	Rohde & Schwarz	101424	2021-01	2023-01
1.7	Opus10 THI (8152.00)	T/H Logger 02	Lufft Mess- und Regeltechnik GmbH	7489	2021-10	2023-10

- 2 R&S TS8997
2.4 and 5 GHz Bands Conducted Test Lab

Ref.No.	Device Name	Description	Manufacturer	Serial Number	Last Calibration	Calibration Due
2.1	MFS	Rubidium Frequency Normal MFS	Datum GmbH	002	2021-11	2022-11
2.2	Opus10 TPR (8253.00)	T/P Logger 13	Lufft Mess- und Regeltechnik GmbH	13936	2021-10	2023-10
2.3	SMB100A	Signal Generator 9 kHz - 6 GHz	Rohde & Schwarz	107695	2021-06	2024-06
2.4	NGSM 32/10	Power Supply	Rohde & Schwarz GmbH & Co. KG	3456	2022-01	2024-01
2.5	FSW43	Signal analyser	Rohde & Schwarz GmbH & Co. KG	102013	2021-06	2023-06
2.6	Opus10 THI (8152.00)	T/H Logger 14	Lufft Mess- und Regeltechnik GmbH	13993	2021-08	2023-08
2.7	SMBV100A	Vector Signal Generator 9 kHz - 6 GHz	Rohde & Schwarz	259291	2019-11	2022-11
2.8	OSP120	Contains Power Meter and Switching Unit OSP-B157W8	Rohde & Schwarz	101158	2021-08	2024-08
2.9	CMX500	Radio Communication Tester New Radio 5G	Rohde & Schwarz GmbH & Co. KG	101305-LP	2020-04	2023-04

3 Radiated Emissions FAR 2.4 GHz FCC
 Radiated emission tests for 2.4 GHz ISM devices in a fully anechoic room

Ref.No.	Device Name	Description	Manufacturer	Serial Number	Last Calibration	Calibration Due
3.1	Opus10 TPR (8253.00)	T/P Logger 13	Lufft Mess- und Regeltechnik GmbH	13936	2021-10	2023-10
3.2	AMF-7D00101800-30-10P-R	Broadband Amplifier 100 MHz - 18 GHz	Miteq			
3.3	Anechoic Chamber 03	FAR, 8.80m x 4.60m x 4.05m (l x w x h)	Albatross Projects	P26971-647-001-PRB	2021-04	2023-04
3.4	Fluke 177	Digital Multimeter 03 (Multimeter)	Fluke Europe B.V.	86670383	2022-06	2024-06
3.5	JS4-18002600-32-5P	Broadband Amplifier 18 GHz - 26 GHz	Miteq	849785		
3.6	FSW 43	Spectrum Analyzer	Rohde & Schwarz	103779	2021-06	2023-06
3.7	EP 1200/B, NA/B1	AC Source, Amplifier with integrated variable Oscillator	Spitzenberger & Spies GmbH & Co. KG	B6278		
3.8	3160-09	Standard Gain / Pyramidal Horn Antenna 26.5 GHz	EMCO Elektronik GmbH	00083069		
3.9	WHKX 7.0/18G-8SS	High Pass Filter	Wainwright Instruments GmbH	09		
3.10	TT 1.5 WI	Turn Table	Maturo GmbH	-		
3.11	5HC3500/18000-1.2-KK	High Pass Filter	Trilithic	200035008		
3.12	Opus 20 THI (8120.00)	ThermoHygro Datalogger	Lufft Mess- und Regeltechnik GmbH	115.0318.0802.033	2020-10	2022-10
3.13	TD1.5-10kg	EUT Tilt Device (Rohacell)	Maturo GmbH	TD1.5-10kg/024/3790709		
3.14	PAS 2.5 - 10 kg	Antenna Mast	Maturo GmbH	-		
3.15	AFS42-00101800-25-S-42	Broadband Amplifier 25 MHz - 18 GHz	Miteq	2035324		
3.16	HF 907	Double-ridged horn	Rohde & Schwarz	102444	2021-09	2024-09

4 Radiated Emissions SAC H-Field
 Radiated emission tests in the H-Field in a semi anechoic room

Ref.No.	Device Name	Description	Manufacturer	Serial Number	Last Calibration	Calibration Due
4.1	Opus10 TPR (8253.00)	T/P Logger 13	Lufft Mess- und Regeltechnik GmbH	13936	2021-10	2023-10
4.2	ESW44	EMI Receiver / Spectrum Analyzer	Rohde & Schwarz GmbH & Co. KG	101603	2022-01	2024-01

Ref.No.	Device Name	Description	Manufacturer	Serial Number	Last Calibration	Calibration Due
4.3	Anechoic Chamber 01	SAC/FAR, 10.58 m x 6.38 m x 6.00 m	Frankonia	none		
4.4	Opus10 THI (8152.00)	T/H Logger 10	Lufft Mess- und Regeltechnik GmbH	12488	2021-08	2023-08
4.5	EP 1200/B, NA/B1	AC Source, Amplifier with integrated variable Oscillator	Spitzenberger & Spies GmbH & Co. KG	B6278		
4.6	DS 420S	Turn Table 2 m diameter	HD GmbH	420/573/99		
4.7	HFH2-Z2	Loop Antenna + 3 Axis Tripod	Rohde & Schwarz GmbH & Co. KG	829324/006	2021-01	2024-01

5 Radiated Emissions SAC up to 1 GHz
 Radiated emission tests up to 1 GHz in a semi anechoic room

Ref.No.	Device Name	Description	Manufacturer	Serial Number	Last Calibration	Calibration Due
5.1	Opus10 TPR (8253.00)	T/P Logger 13	Lufft Mess- und Regeltechnik GmbH	13936	2021-10	2023-10
5.2	ESW44	EMI Receiver / Spectrum Analyzer	Rohde & Schwarz GmbH & Co. KG	101603	2022-01	2024-01
5.3	Anechoic Chamber 01	SAC/FAR, 10.58 m x 6.38 m x 6.00 m	Frankonia	none		
5.4	HL 562 ULTRALOG	Biconical-log-per antenna (30 MHz - 3 GHz) with HL 562E biconicals	Rohde & Schwarz GmbH & Co. KG	830547/003	2021-09	2024-09
5.5	Opus10 THI (8152.00)	T/H Logger 10	Lufft Mess- und Regeltechnik GmbH	12488	2021-08	2023-08
5.6	EP 1200/B, NA/B1	AC Source, Amplifier with integrated variable Oscillator	Spitzenberger & Spies GmbH & Co. KG	B6278		
5.7	DS 420S	Turn Table 2 m diameter	HD GmbH	420/573/99		
5.8	AM 4.0	Antenna Mast 4 m	Maturo GmbH	AM4.0/180/11920513		

The calibration interval is the time interval between "Last Calibration" and "Calibration Due"

7 ANTENNA FACTORS, CABLE LOSS AND SAMPLE CALCULATIONS

This chapter contains the antenna factors with their corresponding path loss of the used measurement path for all antennas as well as the insertion loss of the LISN.

7.1 LISN R&S ESH3-Z5 (150 KHZ – 30 MHZ)

Frequency MHz	Corr. dB	LISN insertion loss ESH3- Z5 dB	cable loss (incl. 10 dB atten- uator) dB
0.15	10.1	0.1	10.0
5	10.3	0.1	10.2
7	10.5	0.2	10.3
10	10.5	0.2	10.3
12	10.7	0.3	10.4
14	10.7	0.3	10.4
16	10.8	0.4	10.4
18	10.9	0.4	10.5
20	10.9	0.4	10.5
22	11.1	0.5	10.6
24	11.1	0.5	10.6
26	11.2	0.5	10.7
28	11.2	0.5	10.7
30	11.3	0.5	10.8

Sample calculation

$$U_{\text{LISN}} \text{ (dB } \mu\text{V)} = U \text{ (dB } \mu\text{V)} + \text{Corr. (dB)}$$

U = Receiver reading

LISN Insertion loss = Voltage Division Factor of LISN

Corr. = sum of single correction factors of used LISN, cables, switch units (if used)

Linear interpolation will be used for frequencies in between the values in the table.

7.2 ANTENNA R&S HFH2-Z2 (9 KHZ – 30 MHZ)

Frequency MHz	AF HFH-Z2) dB (1/m)	Corr. dB	cable loss 1 (inside chamber) dB	cable loss 2 (outside chamber) dB	cable loss 3 (switch unit) dB	cable loss 4 (to receiver) dB	distance corr. (-40 dB/ decade) dB	d _{Limit} (meas. distance (limit) m	d _{used} (meas. distance (used) m
0.009	20.50	-79.6	0.1	0.1	0.1	0.1	-80	300	3
0.01	20.45	-79.6	0.1	0.1	0.1	0.1	-80	300	3
0.015	20.37	-79.6	0.1	0.1	0.1	0.1	-80	300	3
0.02	20.36	-79.6	0.1	0.1	0.1	0.1	-80	300	3
0.025	20.38	-79.6	0.1	0.1	0.1	0.1	-80	300	3
0.03	20.32	-79.6	0.1	0.1	0.1	0.1	-80	300	3
0.05	20.35	-79.6	0.1	0.1	0.1	0.1	-80	300	3
0.08	20.30	-79.6	0.1	0.1	0.1	0.1	-80	300	3
0.1	20.20	-79.6	0.1	0.1	0.1	0.1	-80	300	3
0.2	20.17	-79.6	0.1	0.1	0.1	0.1	-80	300	3
0.3	20.14	-79.6	0.1	0.1	0.1	0.1	-80	300	3
0.49	20.12	-79.6	0.1	0.1	0.1	0.1	-80	300	3
0.490001	20.12	-39.6	0.1	0.1	0.1	0.1	-40	30	3
0.5	20.11	-39.6	0.1	0.1	0.1	0.1	-40	30	3
0.8	20.10	-39.6	0.1	0.1	0.1	0.1	-40	30	3
1	20.09	-39.6	0.1	0.1	0.1	0.1	-40	30	3
2	20.08	-39.6	0.1	0.1	0.1	0.1	-40	30	3
3	20.06	-39.6	0.1	0.1	0.1	0.1	-40	30	3
4	20.05	-39.5	0.2	0.1	0.1	0.1	-40	30	3
5	20.05	-39.5	0.2	0.1	0.1	0.1	-40	30	3
6	20.02	-39.5	0.2	0.1	0.1	0.1	-40	30	3
8	19.95	-39.5	0.2	0.1	0.1	0.1	-40	30	3
10	19.83	-39.4	0.2	0.1	0.2	0.1	-40	30	3
12	19.71	-39.4	0.2	0.1	0.2	0.1	-40	30	3
14	19.54	-39.4	0.2	0.1	0.2	0.1	-40	30	3
16	19.53	-39.3	0.3	0.1	0.2	0.1	-40	30	3
18	19.50	-39.3	0.3	0.1	0.2	0.1	-40	30	3
20	19.57	-39.3	0.3	0.1	0.2	0.1	-40	30	3
22	19.61	-39.3	0.3	0.1	0.2	0.1	-40	30	3
24	19.61	-39.3	0.3	0.1	0.2	0.1	-40	30	3
26	19.54	-39.3	0.3	0.1	0.2	0.1	-40	30	3
28	19.46	-39.2	0.3	0.1	0.3	0.1	-40	30	3
30	19.73	-39.1	0.4	0.1	0.3	0.1	-40	30	3

Sample calculation

$$E \text{ (dB } \mu\text{V/m)} = U \text{ (dB } \mu\text{V)} + AF \text{ (dB 1/m)} + Corr. \text{ (dB)}$$

U = Receiver reading

AF = Antenna factor

Corr. = sum of single correction factors of used cables, switch unit, distance correction, amplifier (if applicable)

distance correction = $-40 * \text{LOG} (d_{\text{Limit}} / d_{\text{used}})$

Linear interpolation will be used for frequencies in between the values in the table.

Table shows an extract of values

7.3 ANTENNA R&S HL562 (30 MHZ – 1 GHZ)

($d_{Limit} = 3\text{ m}$)

Frequency	AF R&S HL562	Corr.
MHz	dB (1/m)	dB
30	18.6	0.6
50	6.0	0.9
100	9.7	1.2
150	7.9	1.6
200	7.6	1.9
250	9.5	2.1
300	11.0	2.3
350	12.4	2.6
400	13.6	2.9
450	14.7	3.1
500	15.6	3.2
550	16.3	3.5
600	17.2	3.5
650	18.1	3.6
700	18.5	3.6
750	19.1	4.1
800	19.6	4.1
850	20.1	4.4
900	20.8	4.7
950	21.1	4.8
1000	21.6	4.9

cable loss 1 (inside chamber)	cable loss 2 (outside chamber)	cable loss 3 (switch unit)	cable loss 4 (to receiver)	distance corr. (-20 dB/decade)	d_{Limit} (meas. distance (limit))	d_{used} (meas. distance (used))
dB	dB	dB	dB	dB	m	m
0.29	0.04	0.23	0.02	0.0	3	3
0.39	0.09	0.32	0.08	0.0	3	3
0.56	0.14	0.47	0.08	0.0	3	3
0.73	0.20	0.59	0.12	0.0	3	3
0.84	0.21	0.70	0.11	0.0	3	3
0.98	0.24	0.80	0.13	0.0	3	3
1.04	0.26	0.89	0.15	0.0	3	3
1.18	0.31	0.96	0.13	0.0	3	3
1.28	0.35	1.03	0.19	0.0	3	3
1.39	0.38	1.11	0.22	0.0	3	3
1.44	0.39	1.20	0.19	0.0	3	3
1.55	0.46	1.24	0.23	0.0	3	3
1.59	0.43	1.29	0.23	0.0	3	3
1.67	0.34	1.35	0.22	0.0	3	3
1.67	0.42	1.41	0.15	0.0	3	3
1.87	0.54	1.46	0.25	0.0	3	3
1.90	0.46	1.51	0.25	0.0	3	3
1.99	0.60	1.56	0.27	0.0	3	3
2.14	0.60	1.63	0.29	0.0	3	3
2.22	0.60	1.66	0.33	0.0	3	3
2.23	0.61	1.71	0.30	0.0	3	3

($d_{Limit} = 10\text{ m}$)

30	18.6	-9.9
50	6.0	-9.6
100	9.7	-9.2
150	7.9	-8.8
200	7.6	-8.6
250	9.5	-8.3
300	11.0	-8.1
350	12.4	-7.9
400	13.6	-7.6
450	14.7	-7.4
500	15.6	-7.2
550	16.3	-7.0
600	17.2	-6.9
650	18.1	-6.9
700	18.5	-6.8
750	19.1	-6.3
800	19.6	-6.3
850	20.1	-6.0
900	20.8	-5.8
950	21.1	-5.6
1000	21.6	-5.6

0.29	0.04	0.23	0.02	-10.5	10	3
0.39	0.09	0.32	0.08	-10.5	10	3
0.56	0.14	0.47	0.08	-10.5	10	3
0.73	0.20	0.59	0.12	-10.5	10	3
0.84	0.21	0.70	0.11	-10.5	10	3
0.98	0.24	0.80	0.13	-10.5	10	3
1.04	0.26	0.89	0.15	-10.5	10	3
1.18	0.31	0.96	0.13	-10.5	10	3
1.28	0.35	1.03	0.19	-10.5	10	3
1.39	0.38	1.11	0.22	-10.5	10	3
1.44	0.39	1.20	0.19	-10.5	10	3
1.55	0.46	1.24	0.23	-10.5	10	3
1.59	0.43	1.29	0.23	-10.5	10	3
1.67	0.34	1.35	0.22	-10.5	10	3
1.67	0.42	1.41	0.15	-10.5	10	3
1.87	0.54	1.46	0.25	-10.5	10	3
1.90	0.46	1.51	0.25	-10.5	10	3
1.99	0.60	1.56	0.27	-10.5	10	3
2.14	0.60	1.63	0.29	-10.5	10	3
2.22	0.60	1.66	0.33	-10.5	10	3
2.23	0.61	1.71	0.30	-10.5	10	3

Sample calculation

$$E \text{ (dB } \mu\text{V/m)} = U \text{ (dB } \mu\text{V)} + \text{AF (dB 1/m)} + \text{Corr. (dB)}$$

U = Receiver reading

AF = Antenna factor

Corr. = sum of single correction factors of used cables, switch unit, distance correction, amplifier (if applicable)

distance correction = $-20 * \text{LOG} (d_{Limit} / d_{used})$

Linear interpolation will be used for frequencies in between the values in the table.

Tables show an extract of values.

7.4 ANTENNA R&S HF907 (1 GHZ – 18 GHZ)

Frequency	AF R&S HF907	Corr.
MHz	dB (1/m)	dB
1000	24.4	-19.4
2000	28.5	-17.4
3000	31.0	-16.1
4000	33.1	-14.7
5000	34.4	-13.7
6000	34.7	-12.7
7000	35.6	-11.0

cable loss 1 (relay + cable inside chamber)	cable loss 2 (outside chamber)	cable loss 3 (switch unit, attenuator & pre-amp)	cable loss 4 (to receiver)		
dB	dB	dB	dB		
0.99	0.31	-21.51	0.79		
1.44	0.44	-20.63	1.38		
1.87	0.53	-19.85	1.33		
2.41	0.67	-19.13	1.31		
2.78	0.86	-18.71	1.40		
2.74	0.90	-17.83	1.47		
2.82	0.86	-16.19	1.46		

Frequency	AF R&S HF907	Corr.
MHz	dB (1/m)	dB
3000	31.0	-23.4
4000	33.1	-23.3
5000	34.4	-21.7
6000	34.7	-21.2
7000	35.6	-19.8

cable loss 1 (relay inside chamber)	cable loss 2 (inside chamber)	cable loss 3 (outside chamber)	cable loss 4 (switch unit, attenuator & pre-amp)	cable loss 5 (to receiver)	used for FCC 15.247
dB	dB	dB	dB	dB	
0.47	1.87	0.53	-27.58	1.33	
0.56	2.41	0.67	-28.23	1.31	
0.61	2.78	0.86	-27.35	1.40	
0.58	2.74	0.90	-26.89	1.47	
0.66	2.82	0.86	-25.58	1.46	

Frequency	AF R&S HF907	Corr.
MHz	dB (1/m)	dB
7000	35.6	-57.3
8000	36.3	-56.3
9000	37.1	-55.3
10000	37.5	-56.2
11000	37.5	-55.3
12000	37.6	-53.7
13000	38.2	-53.5
14000	39.9	-56.3
15000	40.9	-54.1
16000	41.3	-54.1
17000	42.8	-54.4
18000	44.2	-54.7

cable loss 1 (relay inside chamber)	cable loss 2 (High Pass)	cable loss 3 (pre-amp)	cable loss 4 (inside chamber)	cable loss 5 (outside chamber)	cable loss 6 (to receiver)
dB	dB	dB	dB	dB	dB
0.56	1.28	-62.72	2.66	0.94	1.46
0.69	0.71	-61.49	2.84	1.00	1.53
0.68	0.65	-60.80	3.06	1.09	1.60
0.70	0.54	-61.91	3.28	1.20	1.67
0.80	0.61	-61.40	3.43	1.27	1.70
0.84	0.42	-59.70	3.53	1.26	1.73
0.83	0.44	-59.81	3.75	1.32	1.83
0.91	0.53	-63.03	3.91	1.40	1.77
0.98	0.54	-61.05	4.02	1.44	1.83
1.23	0.49	-61.51	4.17	1.51	1.85
1.36	0.76	-62.36	4.34	1.53	2.00
1.70	0.53	-62.88	4.41	1.55	1.91

Sample calculation

$E \text{ (dB } \mu\text{V/m)} = U \text{ (dB } \mu\text{V)} + AF \text{ (dB 1/m)} + Corr. \text{ (dB)}$
 U = Receiver reading
 AF = Antenna factor
 Corr. = sum of single correction factors of used cables, switch unit, distance correction, amplifier (if applicable)
 Linear interpolation will be used for frequencies in between the values in the table.
 Tables show an extract of values.

7.5 ANTENNA EMCO 3160-09 (18 GHZ – 26.5 GHZ)

Frequency MHz	AF EMCO 3160-09 dB (1/m)	Corr. dB	cable loss 1 (inside chamber) dB	cable loss 2 (pre- amp) dB	cable loss 3 (inside chamber) dB	cable loss 4 (switch unit) dB	cable loss 5 (to receiver) dB
18000	40.2	-23.5	0.72	-35.85	6.20	2.81	2.65
18500	40.2	-23.2	0.69	-35.71	6.46	2.76	2.59
19000	40.2	-22.0	0.76	-35.44	6.69	3.15	2.79
19500	40.3	-21.3	0.74	-35.07	7.04	3.11	2.91
20000	40.3	-20.3	0.72	-34.49	7.30	3.07	3.05
20500	40.3	-19.9	0.78	-34.46	7.48	3.12	3.15
21000	40.3	-19.1	0.87	-34.07	7.61	3.20	3.33
21500	40.3	-19.1	0.90	-33.96	7.47	3.28	3.19
22000	40.3	-18.7	0.89	-33.57	7.34	3.35	3.28
22500	40.4	-19.0	0.87	-33.66	7.06	3.75	2.94
23000	40.4	-19.5	0.88	-33.75	6.92	3.77	2.70
23500	40.4	-19.3	0.90	-33.35	6.99	3.52	2.66
24000	40.4	-19.8	0.88	-33.99	6.88	3.88	2.58
24500	40.4	-19.5	0.91	-33.89	7.01	3.93	2.51
25000	40.4	-19.3	0.88	-33.00	6.72	3.96	2.14
25500	40.5	-20.4	0.89	-34.07	6.90	3.66	2.22
26000	40.5	-21.3	0.86	-35.11	7.02	3.69	2.28
26500	40.5	-21.1	0.90	-35.20	7.15	3.91	2.36

Sample calculation

$$E \text{ (dB } \mu\text{V/m)} = U \text{ (dB } \mu\text{V)} + AF \text{ (dB 1/m)} + Corr. \text{ (dB)}$$

U = Receiver reading

AF = Antenna factor

Corr. = sum of single correction factors of used cables, switch unit, distance correction, amplifier (if applicable)

Linear interpolation will be used for frequencies in between the values in the table.

Table shows an extract of values.

7.6 ANTENNA EMCO 3160-10 (26.5 GHZ – 40 GHZ)

Frequency GHz	AF EMCO 3160-10 dB (1/m)	Corr. dB	cable loss 1 (inside chamber) dB	cable loss 2 (outside chamber) dB	cable loss 3 (switch unit) dB	cable loss 4 (to receiver) dB	distance corr. (-20 dB/ decade) dB	d _{Limit} (meas. distance (limit) m	d _{used} (meas. distance (used) m
26.5	43.4	-11.2	4.4				-9.5	3	1.0
27.0	43.4	-11.2	4.4				-9.5	3	1.0
28.0	43.4	-11.1	4.5				-9.5	3	1.0
29.0	43.5	-11.0	4.6				-9.5	3	1.0
30.0	43.5	-10.9	4.7				-9.5	3	1.0
31.0	43.5	-10.8	4.7				-9.5	3	1.0
32.0	43.5	-10.7	4.8				-9.5	3	1.0
33.0	43.6	-10.7	4.9				-9.5	3	1.0
34.0	43.6	-10.6	5.0				-9.5	3	1.0
35.0	43.6	-10.5	5.1				-9.5	3	1.0
36.0	43.6	-10.4	5.1				-9.5	3	1.0
37.0	43.7	-10.3	5.2				-9.5	3	1.0
38.0	43.7	-10.2	5.3				-9.5	3	1.0
39.0	43.7	-10.2	5.4				-9.5	3	1.0
40.0	43.8	-10.1	5.5				-9.5	3	1.0

Sample calculation

$$E \text{ (dB } \mu\text{V/m)} = U \text{ (dB } \mu\text{V)} + \text{AF (dB 1/m)} + \text{Corr. (dB)}$$

U = Receiver reading

AF = Antenna factor

Corr. = sum of single correction factors of used cables, switch unit, distance correction, amplifier (if applicable)

Linear interpolation will be used for frequencies in between the values in the table.

$$\text{distance correction} = -20 * \text{LOG} (d_{\text{Limit}} / d_{\text{used}})$$

Linear interpolation will be used for frequencies in between the values in the table.

Table shows an extract of values.

8 MEASUREMENT UNCERTAINTIES

Test Case	Parameter	Uncertainty
AC Power Line	Power	± 3.4 dB
Field Strength of spurious radiation	Power	± 5.5 dB
6 dB / 26 dB / 99% Bandwidth	Power Frequency	± 2.9 dB ± 11.2 kHz
Conducted Output Power	Power	± 2.2 dB
Band Edge Compliance	Power Frequency	± 2.2 dB ± 11.2 kHz
Frequency Stability	Frequency	± 25 Hz
Power Spectral Density	Power	± 2.2 dB

The measurement uncertainties for all parameters are calculated with an expansion factor (coverage factor) $k = 1.96$. This means, that the true value is in the corresponding interval with a probability of 95 %.

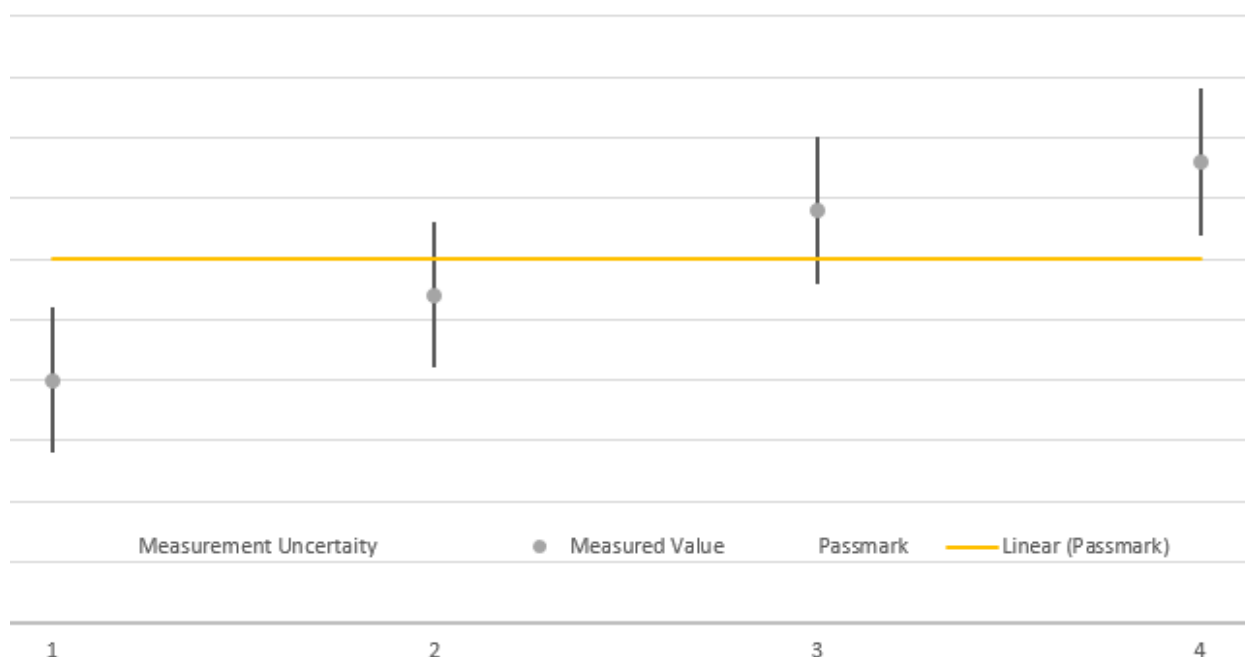

The verdicts in this test report are given according the above diagram:

Case	Measured Value	Uncertainty Range	Verdict
1	below pass mark	below pass mark	Passed
2	below pass mark	within pass mark	Passed
3	above pass mark	within pass mark	Failed
4	above pass mark	above pass mark	Failed

That means, the laboratory applies, as decision rule (see ISO/IEC 17025:2017), the so called shared risk principle.

9 PHOTO REPORT

Please see separate photo report.