

承 認 書

SPECIFICATION FOR APPROVAL

客 戶: **Shenzhen Haitao Technology Co.,Ltd.**

CUSTOMER:

客 戶 料 號:

CUST P/N:

音 澤 料 號:

BESOFTP/N:

產 品 型 號:

14. 9-0. 08*24-12T-6. 5UH-L15MM+**磁铁+BJ**

DESC:

2024/09/13

日 期:

DATE:

版 本:

A.0

Version:

擬 制 PREPARED BY	審 核 CHECKED BY	批 准 APPROVED BY	客 戶 承 認 CUSTOMER APPROVE
何立成	马莉	但可清	

Dongguan Yinze Electronics Co., Ltd.

Factory address: No. 901, Building 2, Xinghan (Wealth Creation Central City), Chashan Town, Dongguan City

但可清

TEL: 18617251159

SPECIFICATION

產品型號: DESC	14.9-0.08*24-12T-6.5UH- L15MM+磁铁+BJ	版本 Rev: A.0	客戶 CUST:	
			音澤料号 Fine P/N:	
			客戶料号 CUST P/N:	

一、尺寸 DIMENSION:(mm)

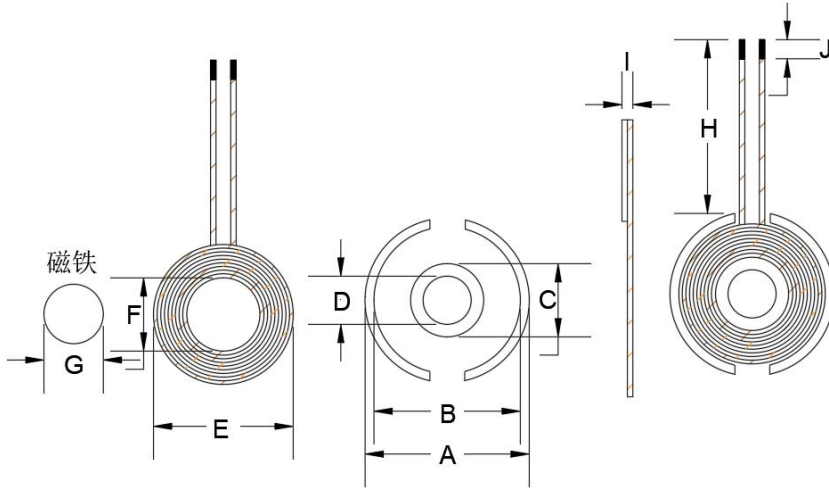

A	24±0.5
B	21±0.5
C	14±0.5
D	8±0.5
E	20.8±0.1
F	14.9±0.5
G	7.5±0.5
H	15±2
J	3±2
I	3.0±0.1

注:

- 1.线圈贴24mm磁片, 磁片尺寸 24±0.5mm,厚度为2.8mm
- 2.磁片背面贴带手撕位圆形直径17mm(ref)普通双面胶。

二、原理图SCHEMATICDIAGR

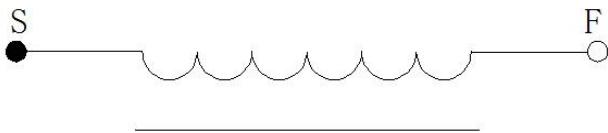



OPPO Reno6 Pro 5G
2024.09.10 15:53

SPECIFICATION

序号 NO.	端子 TERMINAL	线径 WIRE	圈数 Turns	绕线方向 Winding Direction
1	S F	热风线 0.08*24P	12TS	CCW

三、绕线参数 Winding Specification:

四、电气特性 ELECTRICAL CHARACTERISTICS:

温度 TEMPERATURE:25 ±10°C, 湿度 RELATIVE HUMIDITY:65 ±20%

序号 NO.	项目 ITEM	端子 TERMINAL	标准 SPECIFICATION	测试条件 TEST FREQUENCY	测试仪器 TEST EQUIPMENTS
1	IND.	S-F	3.9uH ±20%单独线圈	100KHz/1V	LCZ METER 1062B
2	IND.	S-F	6.5uH ±10%加磁片	100KHz/1V	LCZ METER 1062B
3	Q	S-F	≤3.8	100KHz/1V	LCZ METER 1062B
4	DCR	S-F	≤110mΩ		LCZ METER 502B

5.MATERIAL LIST:

NO	ITEM	DESCRIPTION	RATING	SUPPLIERS	UL NO.	REMARK
	WIRE	热风线	155°C	Guangdong Xinju wire Co., LTD		
	SOLDER	99.3/0.7		Dongguan Feiquan electronic material Co., LTD		
	CORE	24*2.8*14 带槽		Huizhou Huibo Cheng Electronics Co., LTD		
	EPOXY	1603HFR-HS		Dongguan Wan He new material Co., LTD		
	TAPE	PI 260°C		Dongguan die cut charm sound Co., LTD		

1. Tested at 1.0Kz0.25Vrms, 0.1Aac

Average current for 40 temperature rise from 25°C

2. Saturation current(Isat): Inductance drop: 10% typ at Isat.

3. Heat rating current(Irms): 3L@IrmS=AT≤40°C.

4. Electrical specifications at 25°C

5. Storage Temp: -40°C....+85°C

6. Operating Temp: -40°C....+85°C

SPECIFICATION

序号 number	材料名称 Material name	品名描述 Description	制造商 Manufacturer											
1	Hot air wire 0.08*24 strands	Hot air line 0.08*24 strands												
2	Lead-free tin bar	Lead-free tin bar												
3	Magnetic sheet	Φ24mm manganese zinc slotted hard magnetic sheet												
4	Glue	460 glue												
5	Magnet	7.5*2mm												
6	Non-porous double-sided tape	Circular diameter 17mm (ref) adhesive backing												
<table border="1" style="width:100%; border-collapse: collapse;"> <tr> <td rowspan="3" style="width:15%; vertical-align: top;"> 產品型號: DESC </td> <td rowspan="3" style="width:35%; vertical-align: top;"> 14. 9-0. 08*24-12T-6. 5UH- L15MM+磁铁+BJ </td> <td style="width:10%; vertical-align: top;"> 版本 Rev: A.0 </td> <td style="width:15%; vertical-align: top;"> 客戶 CUST: </td> <td style="width:25%;"></td> </tr> <tr> <td></td> <td style="vertical-align: top;"> 音澤料號 Fine P/N: </td> <td></td> </tr> <tr> <td></td> <td style="vertical-align: top;"> 客戶料號 CUST P/N: </td> <td></td> </tr> </table>				產品型號: DESC	14. 9-0. 08*24-12T-6. 5UH- L15MM+磁铁+BJ	版本 Rev: A.0	客戶 CUST:			音澤料號 Fine P/N:			客戶料號 CUST P/N:	
產品型號: DESC	14. 9-0. 08*24-12T-6. 5UH- L15MM+磁铁+BJ	版本 Rev: A.0	客戶 CUST:											
			音澤料號 Fine P/N:											
			客戶料號 CUST P/N:											
擬制/日期 PREPARED BY/DATE		審核/日期 CHECKED BY/DATE												
何立成 2024/09/13														