

# 承 認 書

## SPECIFICATION FOR APPROVAL

音泽料號:  
FINE P/N:

**G43.5\*0.8-20.5-#-10TS-6.5UH-L200MM+BJ**

產品型號:  
DESC:

**Φ43.5MMX0.8MM**

日期:  
DATE:

**2024/03/26**

版本:  
Version:

**A.0**

擬制 PREPARED BY	審核 CHECKED BY	批准 APPROVED BY	客戶承認 CUSTOMER APPROVE
何立成	马莉	但可清	

## 东莞市音泽电子科技有限公司

工廠地址：东莞市茶山镇兴韩路（创富中心城）2栋901号

但可清 TEL: 18617251159

Dongguan Yinze electronic technology Co., LTD

Factory address: No. 901, Building 2, Xinghan Road (Wealth Creation Central City), Chashan Town, Dongguan City



# SPECIFICATION

產品型號: DESC	<b>G43.5*0.8-20.5-#-10TS-6.5UH -L200MM+BJ</b>	版本 Rev: A.0	客戶 CUST: 客戶料号 CUST P/N:	辉码
---------------	---	----------------	----------------------------	----

一、尺寸 DIMENSION:(mm)

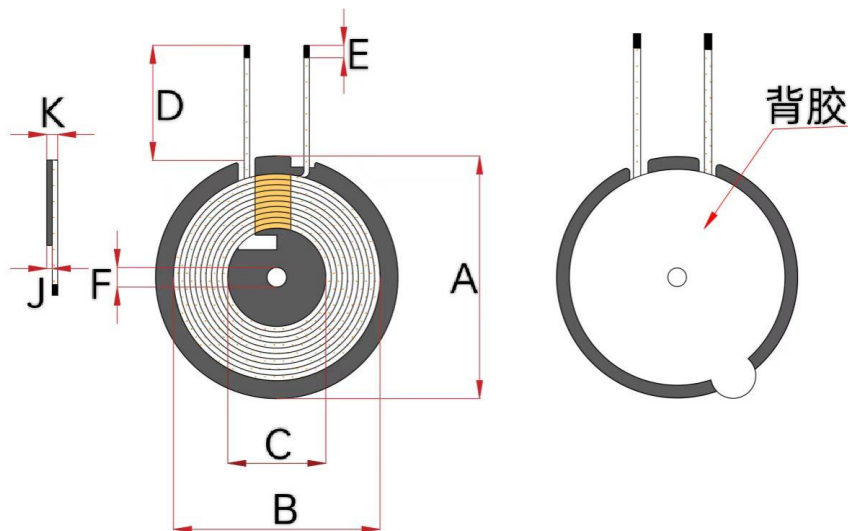

A	43.5±0.5
B	40.5±0.5
C	20.5±0.5
D	200±2
E	3±2
F	5.3±0.2
J	0.8±0.05
K	≤2.3
I	

二、原理图 SCHEMATIC DIAGRAM:

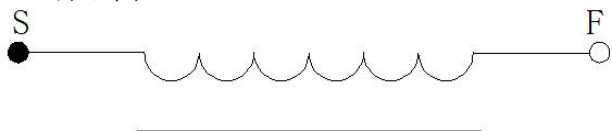

注:

- 1.交叉出线;
- 2.线圈贴双槽磁片，磁片尺寸 43.5±0.5mm, 厚度为 0.8±0.05mm.
- 3.磁片背面贴背胶

三、绕线参数 Winding Specification:

序号 NO.	端子 TERMINAL		线径 WIRE	圈数 Turns	绕线方向 Winding Direction
1	S	F	丝包线#	10Ts	CCW

四、电气特性 ELECTRICAL CHARACTERISTICS:

温度 TEMPERATURE:25±10°C, 湿度 RELATIVE HUMIDITY:65±20%

序号 NO.	项目 ITEM	端子 TERMINAL	标准 SPECIFICATION	测试条件 TEST FREQUENCY	测试仪器 TEST EQUIPMENTS
1	IND.	S-F	3.7uH ±10% Single coil	100KHz/1.0V	LCZ METER 1062B
2	IND.	S-F	6.5uH ±10% Add magnetic disk	100KHz/1.0V	LCZ METER 1062B
3	DCR	S-R	≤70mΩ		LCZ METER 502B
	DCR				

擬制/日期 PREPARED BY/DATE

審核/日期 CHECKED BY/DATE

何立成 2024.03.26