

承认书

Pledge

客户名称 (Client name) :

客户料号 (Client p/NO) :

我司型号 (Model NO) : YZ-G25-2.5-7.6UH-3200GS-7MM -14.5M

送样日期 (Date) : 2023 / 7 / 31

供应方 (Supply-side) : 东莞市捷瑞思科技有限公司

(Dongguan Jieruisi Technology Co., Ltd)

绘制 (protract)	审核 (Audit)	批准 (Ratification)
陆琳 Lu Lin	邓祥桂 Deng Xianggui	陆如圣 Lu Rusheng

客户承认 (Customer acknowledges) :

合格 Eligibility	不合格 (Not eligible)	承认 Recognition
备注 remark		

东

莞捷瑞思科技有限公司 Dongguan Jieruisi Technology Co., Ltd

Tel: _____

Fax: 86+13632701380

地址 Address: 东莞市大岭山镇太公岭村莞长路段 152 号 No. 152, Guanchang Road, Taigongling Village, Dalingshan Town, Dongguan

客户名称 Client	客户料号 Client p/NO	我司型号 Model NO	版本 Edition	日期 Date
瀚彩		YZ-G25-2.5-7.6UH-3200GS-7MM-14.5M	A0	2023.7.31

一、平面结构图 (Floor plan) : 单位 (unit) :MM

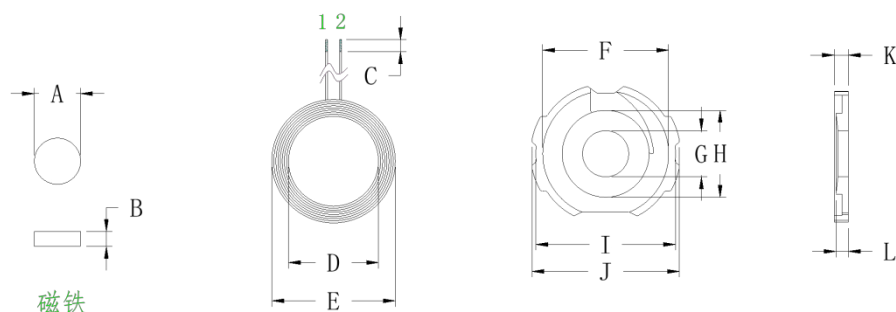

A	7.65±0.05
B	2.0±0.05
C	2±1
D	15±0.2
E	20.7±0.3
F	21±0.2
G	7.7±0.05
H	14.5±0.2
I	23.5±0.3
J	25±0.2
K	2.5±0.15
L	2.4±0.1 中柱高度
M	7±1

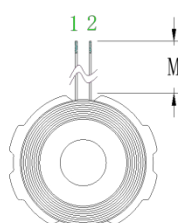

二、产品参数 (Product parameters) :

脚位 foot position	线 径 Line diameter	圈 数 Number of lans	备 注 remark
1 -- 2	0.08*24	13	热风绞合线 Hot air stranded

三、技术要求 Technical requirements: (磁铁磁力为 3200 高斯值 The magnetic ferromagnet is a 3200 Gaussian value)

1. 固定好线头线尾, 防止线松断线等现象 Fix the head and tail of the line to prevent the loosening and breaking line
2. 按客户要求把过长的线头剪, 镀上锡, 镀锡深度统一为 2±1MM According to the customer requirements, the long wire shear, tin plating, tin depth unified for 2 ± 1MM
3. 在软磁片上点上适当的白胶, 贴上线圈, 过程中要保证产品表面干净整洁 Point the appropriate white glue on the soft magnetic sheet, stick the coil, and ensure that the surface of the product is clean and tidy in the process

4. 所用软磁片为带圆孔, 无破损 The soft magnetic sheet used is made with round holes and no damage

5. 附加工序(按客户要求): 于成品中间圆孔装上 7.65x2.0mm 的磁铁并在成品背后加贴直径 14mm 的双面背胶, 后包装 Additional process (according to customer requirements): Install 7.65x2.0mm magnet in the round hole in the middle of the finished product and add 14mm diameter double-sided back tape on the back of the finished product, and pack after it

四、电性参数 Electrical parameters:

1. 电感值 The inductance value, Q 值 q value:

$$\text{PIN } 1 - 2 = 7.6\mu\text{H} \pm 0.2\mu\text{H}$$

$$\text{Q 值 } q \text{ value} \geq 25$$

以上电感值以铨华 1062A 仪器, 以 10KHZ/0.3Vrms 为标准或等同仪器 The above inductance value is the Quanhua 1062A instrument, and 10KHZ/0.3Vrms is the standard or equivalent instrument.。

Q 值以铨华 1062A 仪器, 以 100KHZ/0.3Vrms 为标准或等同仪器 Q value is Quanhua 1062A instrument, 100KHZ/0.3Vrms as the standard or equivalent instrument

五、材料清单 Bill of materia:

序号 orde	名称 name	材质 material quality	供应商 supplier	备注 remark
1	热风绞合线 Hot air stranded wire	0.08X24	维汉或等同 Vihan or equivalent	
2	磁片 magnetic sheet	G25 压铸基材 Die casting substrate	天通或等同 Tiantong or equivalent	
3	锡 Tin	高温环保 High temperature environmental protection	千岛或等同 Thousand islands or equivalent	
4	白胶 Alban	BY882	宝月或等同 Treasure month or equivalent	
5	强磁 Strong magnetic	7.65*2(强度大于 3200GS (Intensity was greater than 3,200 GS))	联胜或等同 United wins or equivalent	附加工序,按客户要求 Additional processes, according to the customer's requirements
6	双面胶 Double-sided tape	513-14mm	鸿辉或等同 Honghui or equivalent	