



# TEST REPORT

**Report Number** : TZ0106240901FRF10  
**Product Name** : Xinli public network intercom  
**Model/Type reference** : K300S  
**FCC ID** : 2BK6D-K300S  
**Prepared for** : Quanzhou Xinli Electronics Co., LTD  
8F, Building 8, Binnan 1st Road, Binjiang Development Zone, Xiamei Town,  
Nanan City, Quanzhou City, Fujian Province, China

**Prepared By** : Shenzhen Tongzhou Testing Co.,Ltd.  
1st Floor, Building 1, Haomai High-tech Park, Huating Road 387, Dalang Street,  
Longhua, Shenzhen, China  
**Standards** : FCC CFR Title 47 Part 22, FCC CFR Title 47 Part 24, FCC CFR Title 47 Part 27,  
ANSI C63.26:2015  
**Date of Test** : August 20, 2024 ~ August 27, 2024  
**Date of Issue** : October 12, 2024

Prepared by : Lena Wen  
(File administrators) Lena Wen

Reviewed by : Hugo Chen  
(Technical Manager) Hugo Chen

Approved by : Andy Zhang  
(General Manager) Andy Zhang



**\*\* Report Revise Record \*\***

<b>Report Version</b>	<b>Revise Time</b>	<b>Issued Date</b>	<b>Valid Version</b>	<b>Notes</b>
V1.0	/	October 12, 2024	Valid	Initial release



## TABLE OF CONTENTS

<b>1.</b>	<b>SUMMARY</b> .....	<b>4</b>
1.1.	Client Information .....	4
1.2.	Description of Device (EUT).....	4
1.3.	Wireless Function Tested in this Report .....	4
1.4.	Normal Accessory setting.....	4
1.5.	Related Submittal(s) / Grant (s) .....	5
1.6.	Modifications .....	5
<b>2.</b>	<b>TEST ENVIRONMENT</b> .....	<b>6</b>
2.1.	Test Facility .....	6
2.2.	Measurement uncertainty .....	6
<b>3.</b>	<b>SUMMARY OF TEST RESULTS</b> .....	<b>7</b>
3.1.	Environmental conditions .....	8
<b>4.</b>	<b>EQUIPMENTS USED DURING THE TEST</b> .....	<b>9</b>
<b>5.</b>	<b>TEST CONDITIONS AND RESULTS</b> .....	<b>10</b>
5.1.	Conducted Output Power / E.I.R.P / E.R.P / Peak-to-Average Ratio (PAR).....	10
5.2.	Occupied Bandwidth and Emission Bandwidth .....	12
5.3.	Band Edge compliance .....	13
5.4.	Spurious Emssion on Antenna Port .....	15
5.5.	Radiated Spurious Emssion .....	16
5.6.	Frequency Stability under Temperature & Voltage Variations.....	24
<b>6.</b>	<b>TEST SETUP PHOTOS OF THE EUT</b> .....	<b>26</b>
<b>7.</b>	<b>EXTERNAL PHOTOS OF THE EUT</b> .....	<b>26</b>
<b>8.</b>	<b>INTERNAL PHOTOS OF THE EUT</b> .....	<b>26</b>



## 1. SUMMARY

### 1.1. Client Information

Applicant	: Quanzhou Xinli Electronics Co., LTD
Address	: 8F, Building 8, Binnan 1st Road, Binjiang Development Zone, Xiamei Town, Nanan City, Quanzhou City, Fujian Province, China
Manufacturer	: Quanzhou Xinli Electronics Co., LTD
Address	: 8F, Building 8, Binnan 1st Road, Binjiang Development Zone, Xiamei Town, Nanan City, Quanzhou City, Fujian Province, China

### 1.2. Description of Device (EUT)

Product Name	: Xinli public network intercom
Trade Mark	: XINLIZP
Model Number	: K300S
Model Declaration	: N/A
Test Model	: K300S
Power Supply	: DC 3.7V by battery
Hardware version	: V0.1A
Software version	: V008_1.011.069

### 1.3. Wireless Function Tested in this Report

E-UTRA	
E-UTRA FCC Operation Frequency	: FDD Band 2 (UL: 1850 – 1910 MHz/DL: 1930 – 1990 MHz) FDD Band 4 (UL: 1710 – 1755 MHz/DL: 2110 – 2155 MHz) FDD Band 5 (UL: 824 – 849 MHz/DL: 869 – 894 MHz) FDD Band 7(UL: 2500 – 2570 MHz/DL:2620 – 2690 MHz) TDD Band 38(UL: 2570 – 2620 MHz/DL: 2570 – 2620 MHz) TDD Band 41(UL: 2496 MHz - 2690 MHz/DL: 2496 - 2690 MHz)
Channel Separation	: 0.1 MHz
Modulation Technology	: OFDM (16QAM, QPSK)
Antenna Type And Gain	: Internal Antenna FDD Band 2:1.75 dBi, FDD Band 4:1.71 dBi, FDD Band 5:1.20 dBi, FDD Band 7:1.94 dBi, TDD Band 38:1.70 dBi, TDD Band 41:1.96 dBi

Note 1: Antenna position refer to EUT Photos.

Note 2: the above information was supplied by the applicant.

### 1.4. Normal Accessory setting

Fully charged battery was used during the test.



Report No.: TZ0106240901FRF10

### **1.5. Related Submittal(s) / Grant (s)**

This submittal(s) (test report) is intended for **FCC ID: 2BK6D-K300S** filing to comply with FCC Rules.

### **1.6. Modifications**

No modifications were implemented to meet testing criteria.



## 2. TEST ENVIRONMENT

### 2.1. Test Facility

#### FCC

Designation Number: CN1275

Test Firm Registration Number: 167722

Shenzhen Tongzhou Testing Co.,Ltd has been listed on the US Federal Communications Commission list of test facilities recognized to perform electromagnetic emissions measurements.

#### A2LA

Certificate Number: 5463.01

Shenzhen Tongzhou Testing Co.,Ltd has been listed by American Association for Laboratory Accreditation to perform electromagnetic emission measurement.

#### IC

ISED#: 22033

CAB identifier: CN0099

Shenzhen Tongzhou Testing Co.,Ltd has been listed by Innovation, Science and Economic Development Canada to perform electromagnetic emission measurement.

The 3m-Semi anechoic test site fulfils CISPR 16-1-4 according to ANSI C63.4 and CISPR 16-1-4:2010

### 2.2. Measurement uncertainty

The data and results referenced in this document are true and accurate. The reader is cautioned that there may be errors within the calibration limits of the equipment and facilities. The measurement uncertainty was calculated for all measurements listed in this test report acc. to ETSI TR 100 028 " Electromagnetic compatibility and Radio spectrum Matters (ERM); Uncertainties in the measurement of mobile radio equipment characteristics" and is documented in the Shenzhen Tongzhou Testing Co.,Ltd. quality system acc. to ISO/IEC 17025. Furthermore, component and process variability of devices similar to that tested may result in additional deviation. The manufacturer has the sole responsibility of continued compliance of the device.

Hereafter the best measurement capability for Shenzhen Tongzhou Testing Co.,Ltd. is reported:

Test	Range	Measurement Uncertainty	Notes
Radiated Emission	30~1000MHz	3.10 dB	(1)
Radiated Emission	1~18GHz	3.70 dB	(1)
Radiated Emission	18-40GHz	3.90 dB	(1)
Conducted Disturbance	0.15~30MHz	1.63 dB	(1)
Conducted Power	9KHz~18GHz	0.61 dB	(1)
Spurious RF Conducted Emission	9KHz~40GHz	1.22 dB	(1)
Band Edge Compliance of RF Emission	9KHz~40GHz	1.22 dB	(1)
Occupied Bandwidth	9KHz~40GHz	-	(1)
Frequency Error	9KHz~40GHz	$1 \times 10^{-7}$	(1)

(1) This uncertainty represents an expanded uncertainty expressed at approximately the 95% confidence level using a coverage factor of  $k=1.96$ .



### 3. SUMMARY OF TEST RESULTS

#### FDD Band 2[Part 24]

Test Item	FCC Rule No.	Requirements	Judgement	Sample ID
Effective (Isotropic) Radiated Power	2.1046, 24.232(c)	EIRP ≤ 2W(33dBm)	Pass	TZ0106240902-1#
Bandwidth	2.1049 24.238(a)	OBW: No limit. EBW: No limit.	Pass	TZ0106240902-1#
Band Edges	2.1051, 24.238(a)	-13dBm	Pass	TZ0106240902-1#
Spurious Emission at Antenna Terminals	2.1051, 24.238(a)	-13dBm	Pass	TZ0106240902-1#
Field Strength of Spurious Radiation	2.1053, 24.238(a)	-13dBm	Pass	TZ0106240902-2#
Frequency Stability	2.1055, 24.235	the fundamental emission stays within the authorized frequency block.	Pass	TZ0106240902-1#
Peak to average ratio	24.232(d)	<13dB	Pass	TZ0106240902-1#

#### FDD Band 5[Part 22]

Test Item	FCC Rule No.	Requirements	Judgement	Sample ID
Effective (Isotropic) Radiated Power	2.1046, 22.913(a)	ERP ≤ 7W(38.5dBm)	Pass	TZ0106240902-1#
Occupied Bandwidth	2.1049	OBW: No limit.	Pass	TZ0106240902-1#
Emission Bandwidth	22.917(b)	EBW: No limit.	Pass	TZ0106240902-1#
Band Edges Compliance	2.1051, 22.917(a)(b)	-13dBm	Pass	TZ0106240902-1#
Spurious Emission at Antenna Terminals	2.1051, 22.917	-13dBm	Pass	TZ0106240902-1#
Field Strength of Spurious Radiation	2.1053, 22.917	-13dBm	Pass	TZ0106240902-2#
Frequency Stability	2.1055, 22.355	the fundamental emissions stay within the authorized bands of operation. (2.5ppm)	Pass	TZ0106240902-1#
Peak to average ratio	2.1046, 22.913(a)	<13dB	Pass	TZ0106240902-1#

#### FDD Band 4[Part 27]

Test Item	FCC Rule No.	Requirements	Judgement	Sample ID
Effective (Isotropic) Radiated Power	2.1046, 27.50(d)	EIRP ≤ 1W(30dBm)	Pass	TZ0106240902-1#
Occupied Bandwidth	2.1049	OBW: No limit.	Pass	TZ0106240902-1#
Emission Bandwidth	2.1049	EBW: No limit.	Pass	TZ0106240902-1#
Band Edges Compliance	2.1051, 27.53(h)	≤ -13 dBm/1%*EBW, in 1 MHz bands immediately outside and adjacent to the frequency block.	Pass	TZ0106240902-1#
Spurious Emission at Antenna Terminals	2.1051, 27.53(h)	-13dBm	Pass	TZ0106240902-1#
Field Strength of Spurious Radiation	2.1053, 27.53(h)	-13dBm	Pass	TZ0106240902-2#
Frequency Stability	2.1055, 27.54	the fundamental emissions stay within the authorized bands of operation. (2.5ppm)	Pass	TZ0106240902-1#
Peak to average ratio	2.1046, 27.50(d)	<13dB	Pass	TZ0106240902-1#



**FDD Band 7/38/41[Part 27]**

Test Item	FCC Rule No.	Requirements	Judgement	Sample ID
Effective (Isotropic) Radiated Power	2.1046, 27.50(h)(2)	EIRP ≤ 2W(33dBm)	Pass	TZ0106240902-1#
Occupied Bandwidth	2.1049	OBW: No limit.	Pass	TZ0106240902-1#
Emission Bandwidth	2.1049	EBW: No limit.	Pass	TZ0106240902-1#
Band Edges(Out of Band Emission) Compliance	2.1051, 27.53(m)	KDB 971 168 D02 971168 D02 Misc OOBE License Digital Systems v01 &27.53(m) for detail the limit is upon different OBW	Pass	TZ0106240902-1#
Spurious Emission at Antenna Terminals	2.1051, 27.53(g)	-25dBm	Pass	TZ0106240902-1#
Field Strength of Spurious Radiation	2.1053, 27.53(g)	-25dBm	Pass	TZ0106240902-2#
Frequency Stability	2.1055, 27.54	the fundamental emissions stay within the authorized bands of operation. (2.5ppm)	Pass	TZ0106240902-1#
Peak to average ratio	2.1046, 27.50(d)	<13dB	Pass	TZ0106240902-1#

Remark: The measurement uncertainty is not included in the test result.

**3.1. Environmental conditions**

During the measurement the environmental conditions were within the listed ranges:

Temperature:	15-35 ° C
Humidity:	30-60 %
Atmospheric pressure:	950-1050mbar





#### 4. EQUIPMENTS USED DURING THE TEST

Item	Test Equipment	Manufacturer	Model No.	Serial No.	Calibration Date	Calibration Due Date
1	MXA Signal Analyzer	Keysight	N9020A	MY52091623	2024/1/4	2025/1/3
2	Power Sensor	Agilent	U2021XA	MY5365004	2024/1/4	2025/1/3
3	Loop Antenna	schwarzbeck	FMZB1519 B	00023	2022/11/13	2025/11/12
4	Wideband Antenna	schwarzbeck	VULB 9163	958	2022/11/13	2025/11/12
5	Horn Antenna	schwarzbeck	BBHA 9120D	01989	2022/11/13	2025/11/12
6	EMI Test Receiver	R&S	ESCI	100849/003	2024/1/4	2025/1/3
7	Controller	MF	MF7802	N/A	N/A	N/A
8	Amplifier	schwarzbeck	BBV 9743	209	2024/1/4	2025/1/3
9	Amplifier	Tonscend	TSAMP-0518SE	--	2024/1/4	2025/1/3
10	RF Cable(below 1GHz)	HUBER+SUHNER	RG214	N/A	2024/1/4	2025/1/3
11	RF Cable(above 1GHz)	HUBER+SUHNER	RG214	N/A	2024/1/4	2025/1/3
12	RE test software	Tonscend	JS32-RE	V5.0.0.0	N/A	N/A
12	Test Software	Tonscend	JS1120-3	V3.2.22	N/A	N/A
14	Horn Antenna	A-INFO	LB-180400-KF	J211020657	2024/1/4	2025/1/3
15	Amplifier	Chengyi	EMC18404 5SE	980508	2024/9/20	2025/9/19
16	Spectrum Analyzer	R&S	FSP40	100550	2024/1/10	2025/1/10
17	UNIVERSAL RADIO COMMUNICATION	R&S	CMW500	101855	2024/1/4	2025/1/3
18	Signal Generator	Keysight	N5182A	MY4620709	2024/1/4	2025/1/3



## 5. TEST CONDITIONS AND RESULTS

### 5.1. Conducted Output Power / E.I.R.P / E.R.P / Peak-to-Average Ratio (PAR)

#### 5.1.1. TEST APPLICABLE

During the process of testing, the EUT was controlled via R&S Digital Radio Communication tester (CMW500) to ensure max power transmission and proper modulation. This result contains output power and EIRP measurements for the EUT. In all cases, output power is within the specified limits.

#### 5.1.2. LIMIT

##### **For Conducted Power**

Within Tune-up Value

##### **For Radiated Power**

This is the test for the maximum radiated power from the EUT.

Per Part 22.913(a)(4) The ERP of mobile transmitters and auxiliary test transmitters must not exceed 7 watts.

Per Part 24.232(c) Mobile and portable stations are limited to 2 watts EIRP and the equipment must employ a means for limiting power to the minimum necessary for successful communications.

Per Part 27.50(d) (4) specifies, Fixed, mobile, and portable (hand-held) stations operating in the 1710-1755MHz band are limited to 1W EIRP. Fixed stations operating in this band are limited to a maximum antenna height of 10 meters above ground. Mobile and portable stations operating in this band must employ a means for limiting power to the minimum necessary for successful communications.

Per Part 27.50 (c) (10) the following power and antenna height requirements apply to stations transmitting in the 698–746 MHz band, the portable stations (hand-held devices) are limited to 3 watts ERP.

Per Part 27.50(b) (9) specifies, Control stations and mobile stations transmitting in the 746-757 MHz, 776-788 MHz, and 805-806 MHz bands and fixed stations transmitting in the 787-788 MHz and 805-806 MHz bands are limited to 30 watts ERP.

Per Part 27.50(b)(10) specifies, Portable stations (hand-held devices) transmitting in the 746-757 MHz, 776-788 MHz, and 805-806 MHz bands are limited to 3 watts ERP.

Per Part 27.50(a) (3) specifies, *Mobile and portable stations*. (i) For mobile and portable stations transmitting in the 2305-2315 MHz band or the 2350-2360 MHz band, the average EIRP must not exceed 50 milliwatts within any 1 megahertz of authorized bandwidth, *except that* for mobile and portable stations compliant with 3GPP LTE standards or another advanced mobile broadband protocol that avoids concentrating energy at the edge of the operating band the average EIRP must not exceed 250 milliwatts within any 5 megahertz of authorized bandwidth but may exceed 50 milliwatts within any 1 megahertz of authorized bandwidth. For mobile and portable stations using time division duplexing (TDD) technology, the duty cycle must not exceed 38 percent in the 2305-2315 MHz and 2350-2360 MHz bands. Mobile and portable stations using FDD technology are restricted to transmitting in the 2305-2315 MHz band. Power averaging shall not include intervals in which the transmitter is off.

Per Part 27.50(h) (2) specifies, The following power limits shall apply in the BRS and EBS: *Mobile and other user stations*. Mobile stations are limited to 2.0 watts EIRP. All user stations are limited to 2.0 watts transmitter output power.

##### **For Peak-to-Average Ratio (PAR)**

The Peak-to-Average Ratio (PAR) of the transmission may not exceed 13 dB.



### 5.1.3. TEST CONFIGURATION

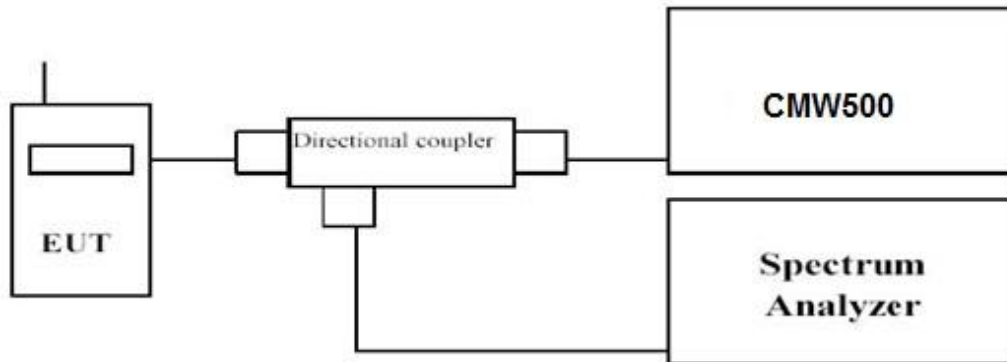

### 5.1.4. TEST PROCEDURE

1. Place the EUT on a bench and set it in transmitting mode.
2. Connect a low loss RF cable from the antenna port to a CMW500 by an Att.
3. EUT Communicate with CMW500 then selects a channel for testing.
4. Add a correction factor to the display CMW500, and then test.
5. Record the Peak power(P1) and Average power(P2).
6. Peak-to-Average Ratio (PAR) = Peak power(P1) - Average power(P2)
7. EIRP = Average power(P2) + Antenna Gain(dBi), ERP can be calculated from EIRP by subtracting the gain of the dipole, ERP = EIRP-2.15dBi.

### 5.1.5. TEST RESULTS

#### Pass

#### Remark:

1. We were tested all RB Configuration refer 3GPP TS136 521 for each Channel Bandwidth as list in section 3.3 of this report;
2. please refer to Output Power and Peak-to-Average Ratio (PAR) in Appendix Test data for LTE Band2.
3. please refer to Output Power and Peak-to-Average Ratio (PAR) in Appendix Test data for LTE Band4.
4. please refer to Output Power and Peak-to-Average Ratio (PAR) in Appendix Test data for LTE Band5.
5. please refer to Output Power and Peak-to-Average Ratio (PAR) in Appendix Test data for LTE Band7.
6. please refer to Output Power and Peak-to-Average Ratio (PAR) in Appendix Test data for LTE Band38.
7. please refer to Output Power and Peak-to-Average Ratio (PAR) in Appendix Test data for LTE Band41.



## 5.2. Occupied Bandwidth and Emission Bandwidth

### 5.2.1. LIMIT

N/A

### 5.2.2. TEST CONFIGURATION

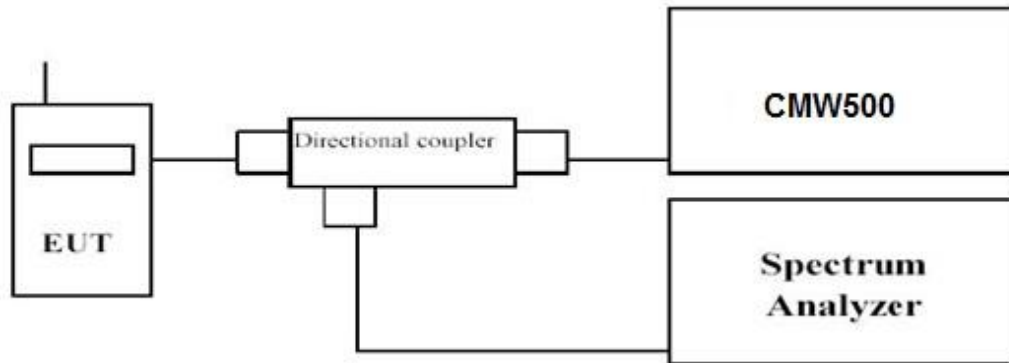

### 5.2.3. TEST PROCEDURE

The transmitter output was connected to a calibrated coaxial cable and coupler, the other end of which was connected to a spectrum analyzer. The occupied bandwidth was measured with the spectrum analyzer at low, middle and high channel in each band. The -26dBc Emission bandwidth was also measured and recorded. Set RBW was set to about 1% of emission BW, VBW $\geq$ 3 times RBW.

-26dBc display line was placed on the screen (or 99% bandwidth), the occupied bandwidth is the delta frequency between the two points where the display line intersects the signal trace.

### 5.2.4. TEST RESULTS

**Pass**

Remark:

1. We were tested full RB Configuration refer 3GPP TS136 521 for each Channel Bandwidth as list in section 3.3 of this report;
2. please refer to Emission bandwidth and OBW in Appendix Test data for LTE Band2.
3. please refer to Emission bandwidth and OBW in Appendix Test data for LTE Band4.
4. please refer to Emission bandwidth and OBW in Appendix Test data for LTE Band5.
5. please refer to Emission bandwidth and OBW in Appendix Test data for LTE Band7.
6. please refer to Emission bandwidth and OBW in Appendix Test data for LTE Band38.
7. please refer to Emission bandwidth and OBW in Appendix Test data for LTE Band41.



### 5.3. Band Edge compliance

#### 5.3.1. LIMIT

*For LTE FDD Band 2:* Per §24.238(a): Out of band emissions. The power of any emission outside of the authorized operating frequency ranges must be attenuated below the transmitting power (P) by a factor of at least  $43 + 10 \log(P)$  dB.

*For LTE FDD Band 5:* Per 22.917(a): The power of any emission outside of the authorized operating frequency ranges must be attenuated below the transmitting power (P) by a factor of at least  $43 + 10 \log(P)$  dB.

*For LTE FDD Band 4:* Per §27.53(h): For operations in the 814–849 MHz band, the power of any emission outside of the authorized operating frequency ranges must be attenuated below the transmitting power (P) by a factor of at least  $43 + 10 \log(P)$  dB.

*For LTE FDD Band 7/38/41:* Per §27.53(m)(4): For mobile digital stations, the attenuation factor shall be not less than  $40 + 10 \log(P)$  dB on all frequencies between the channel edge and 5 megahertz from the channel edge,  $43 + 10 \log(P)$  dB on all frequencies between 5 megahertz and X megahertz from the channel edge, and  $55 + 10 \log(P)$  dB on all frequencies more than X megahertz from the channel edge, where X is the greater of 6 megahertz or the actual emission bandwidth as defined in paragraph (m)(6) of this section. In addition, the attenuation factor shall not be less than  $43 + 10 \log(P)$  dB on all frequencies between 2490.5 MHz and 2496 MHz and  $55 + 10 \log(P)$  dB at or below 2490.5 MHz. Mobile Satellite Service licensees operating on frequencies below 2495 MHz may also submit a documented interference complaint against BRS licensees operating on channel BRS Channel 1 on the same terms and conditions as adjacent channel BRS or EBS licensees.

#### 5.3.2. TEST CONFIGURATION

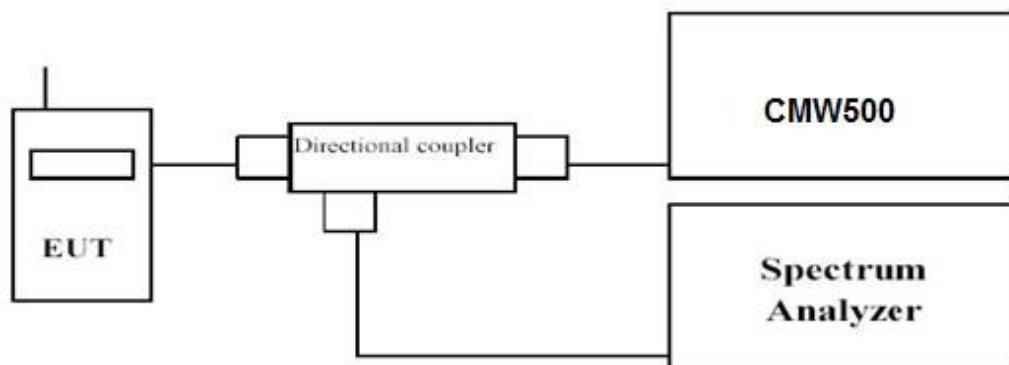

#### 5.3.3. TEST PROCEDURE

1. The transmitter output port was connected to base station.
2. The RF output of EUT was connected to the power meter by RF cable and attenuator, the path loss was compensated to the results for each measurement.
3. Set EUT at maximum power through base station.
4. Select lowest and highest channels for each band and different modulation.
5. Measure Band edge using RMS (Average) detector by spectrum

#### 5.3.4. TEST RESULTS



**Pass**

Remark:

1. We were tested all RB Configuration refer 3GPP TS136 521 for each Channel Bandwidth as list in section 3.3 of this report;
2. please refer to Band Edge and Emission Mask in Appendix Test data for LTE Band2.
3. please refer to Band Edge and Emission Mask in Appendix Test data for LTE Band4.
4. please refer to Band Edge and Emission Mask in Appendix Test data for LTE Band5.
5. please refer to Band Edge and Emission Mask in Appendix Test data for LTE Band7.
6. please refer to Band Edge and Emission Mask in Appendix Test data for LTE Band38.
7. please refer to Band Edge and Emission Mask in Appendix Test data for LTE Band41.



## 5.4. Spurious Emission on Antenna Port

### 5.4.1. LIMIT

Refer to section 3.3 of this report for each frequency band

### 5.4.2. TEST CONFIGURATION

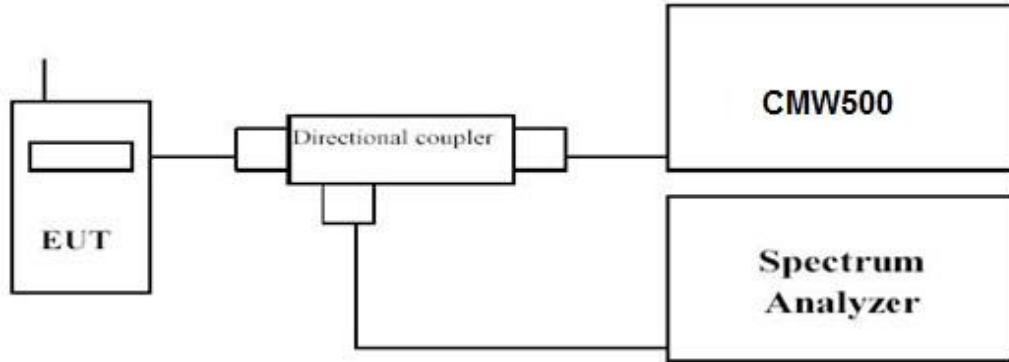

### 5.4.3. TEST PROCEDURE

The EUT was setup according to ANSI C63.26

- Place the EUT on a bench and set it in transmitting mode.
- Connect a low loss RF cable from the antenna port to a spectrum analyzer and CMW500 by a Directional Couple.
- EUT Communicate with CMW500, then select a channel for testing.
- Add a correction factor to the display of spectrum, and then test.
- The resolution bandwidth of the spectrum analyzer was set sufficient scans were taken to show the out of band Emission if any up to 10<sup>th</sup> harmonic.
- Please refer to following tables for test antenna conducted emissions.

Sub range (GHz)	RBW	VBW	Sweep time (s)
0.000009~0.000015	1KHz	3KHz	Auto
0.000015~0.03	10KHz	30KHz	Auto
0.03~26	1 MHz	3 MHz	Auto

### 5.4.4. TEST RESULTS

#### Pass

Remark:

- We were tested all RB Configuration refer 3GPP TS136 521 for each Channel Bandwidth as list in section 3.3 of this report;
- please refer to Conducted Spurious Emission in Appendix Test data for LTE Band2.
- please refer to Conducted Spurious Emission in Appendix Test data for LTE Band4.
- please refer to Conducted Spurious Emission in Appendix Test data for LTE Band5.
- please refer to Conducted Spurious Emission in Appendix Test data for LTE Band7.
- please refer to Conducted Spurious Emission in Appendix Test data for LTE Band38.
- please refer to Conducted Spurious Emission in Appendix Test data for LTE Band41.



## 5.5. Radiated Spurious Emission

### 5.5.1. LIMIT

Refer to section 3.3 of this report for each frequency band

### 5.5.2. TEST CONFIGURATION

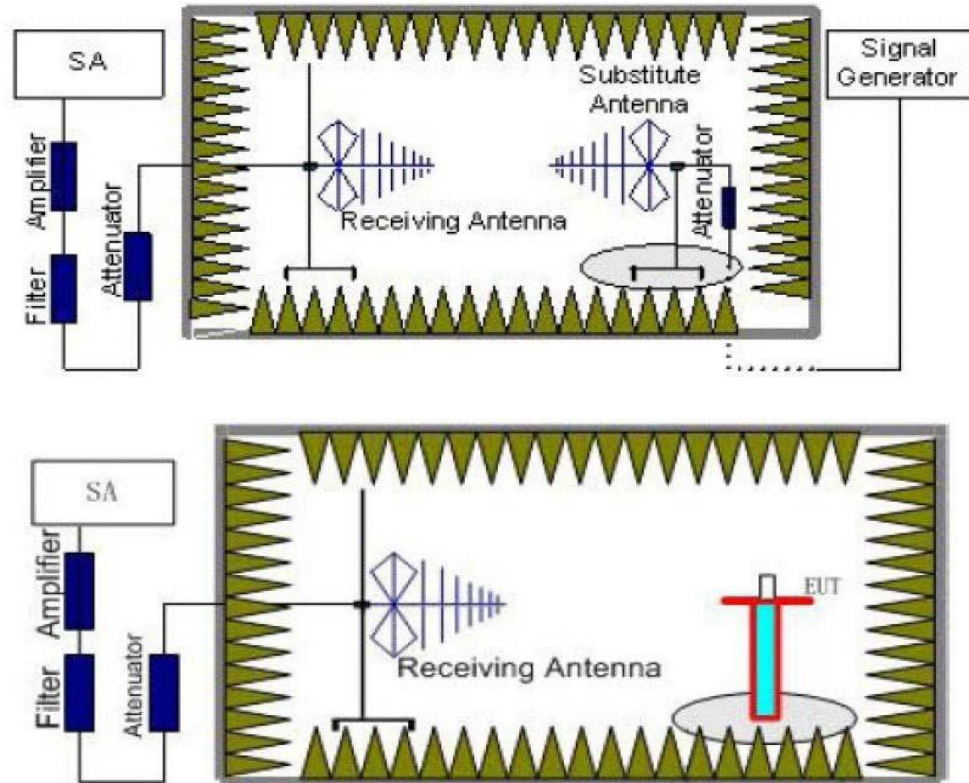

### 5.5.3. TEST PROCEDURE

1. Setup as illustrated above the DUT placed on the 0.8m height (for frequencies < 1GHz) or 1.5m (for frequencies > 1GHz) of Turn Table, rotated the table around 360 degrees to search the maximum radiation power and receiver antenna shall be rotated vertical and horizontal polarization and moved height from 1m to 4m to find the maximum polar radiated power.
2. A log-periodic antenna or double-ridged waveguide horn antenna shall be substituted in place of the EUT. The log-periodic antenna will be driven by a signal generator and the level will be adjusted till the same power value on the spectrum analyzer or receiver. The level of the spurious emissions can be calculated through the level of the signal generator, cable loss, the gain of the substitution antenna and the reading of the spectrum analyzer or receiver.
3. The EUT is then put into continuously transmitting mode at its maximum power level during the test. Set Test Receiver or Spectrum RBW=1MHz, VBW=3MHz, And the maximum value of the receiver should be recorded as ( $P_r$ ).
4. The EUT shall be replaced by a substitution antenna. In the chamber, a substitution antenna for the frequency band of interest is placed at the reference point of the chamber. An RF Signal source for the frequency band of interest is connected to the substitution antenna with a cable that has been constructed to not interfere with the radiation pattern of the antenna. A power ( $P_{Mea}$ ) is applied to the input of the substitution antenna, and adjust the level of the signal generator output until the value of the receiver reach the





previously recorded ( $P_r$ ). The power of signal source ( $P_{Mea}$ ) is recorded. The test should be performed by rotating the test item and adjusting the receiving antenna polarization.

5. A amplifier should be connected to the Signal Source output port. And the cable should be connect between the Amplifier and the Substitution Antenna. The cable loss ( $P_{cl}$ ), the Substitution Antenna Gain ( $G_a$ ) and the Amplifier Gain ( $P_{Ag}$ ) should be recorded after test.

The measurement results are obtained as described below:  $Power(EIRP) = P_{Mea} + P_{Ag} - P_{cl} + G_a$

It can omit power amplifier if signal generator level meets requirement;

6. This value is EIRP since the measurement is calibrated using an antenna of known gain (2.15 dBi) and known input power.

7. ERP can be calculated from EIRP by subtracting the gain of the dipole,  $ERP = EIRP - 2.15dBi$ .

8. In order to make sure test results more clearly, we set frequency range and sweep time for difference frequency range as follows table:

Subrange (GHz)	RBW	VBW	Sweep time (s)
0.00009~0.15	1KHz	3KHz	30
0.00015~0.03	10KHz	30KHz	10
0.03~1	100KHz	300KHz	10
1~2	1 MHz	3 MHz	2
2~5	1 MHz	3 MHz	3
5~8	1 MHz	3 MHz	3
8~10 <sup>th</sup>	1 MHz	3 MHz	3

#### 5.5.4. TEST LIMITS

According to rules specify that the power of any emission outside of the authorized operating frequency ranges must be attenuated below the transmitting power (P) by a factor of at least  $43 + 10 \log(P)$  dB. The specification that emissions shall be attenuated below the transmitter power (P) by at least  $43 + 10 \log(P)$  dB, translates in the relevant power range (1 to 0.001 W) to -13 dBm. At 1 W the specified minimum attenuation becomes 43 dB and relative to a 30 dBm (1 W) carrier becomes a limit of -13 dBm. At 0.001 W (0 dBm) the minimum attenuation is 13 dB, which again yields a limit of -13 dBm. In this way a translation of the specification from relative to absolute terms is carried out.

Channel	Frequency Range	Verdict
Low	9 KHz – 10 <sup>th</sup> GHz	PASS
Middle	9 KHz – 10 <sup>th</sup> GHz	PASS
High	9 KHz – 10 <sup>th</sup> GHz	PASS

#### 5.5.5. TEST RESULTS

##### Pass

Temperature	24.8°C	Humidity	58%
Test Engineer	Anna Hu		

Remark:

1. We tested all RB Configuration refer 3GPP TS136 521 for each Channel Bandwidth as list in section 3.3 of this report;
2.  $EIRP = P_{Mea}(dBm) - P_{cl}(dB) + G_a(dBi)$
3. We were not recorded other points as values lower than limits.
4.  $Margin = EIRP - Limit$



*LTE FDD Band 2\_Channel Bandwidth 5MHz\_QPSK\_Low Channel*

Frequency (MHz)	P <sub>Mea</sub> (dBm)	P <sub>cl</sub> (dB)	Diatance	G <sub>a</sub> Antenna Gain(dB)	Peak EIRP (dBm)	Limit (dBm)	Margin (dB)	Polarization
3705	-53.68	1.26	3	12.1	-42.84	-13	29.84	H
3705	-56.25	1.26	3	12.1	-45.41	-13	32.41	V
5557.5	-52.44	1.7	3	12.58	-41.56	-13	28.56	H
5557.5	-55.51	1.7	3	12.58	-44.63	-13	31.63	V

*LTE FDD Band 2\_Channel Bandwidth 5MHz\_QPSK\_Middle Channel*

Frequency (MHz)	P <sub>Mea</sub> (dBm)	P <sub>cl</sub> (dB)	Diatance	G <sub>a</sub> Antenna Gain(dB)	Peak EIRP (dBm)	Limit (dBm)	Margin (dB)	Polarization
3760	-54.19	1.28	3	12.16	-43.31	-13	30.31	H
3760	-58.53	1.28	3	12.16	-47.65	-13	34.65	V
5640	-47.71	1.72	3	12.62	-36.81	-13	23.81	H
5640	-58.83	1.72	3	12.62	-47.93	-13	34.93	V

*LTE FDD Band 2\_Channel Bandwidth 5MHz\_QPSK\_High Channel*

Frequency (MHz)	P <sub>Mea</sub> (dBm)	P <sub>cl</sub> (dB)	Diatance	G <sub>a</sub> Antenna Gain(dB)	Peak EIRP (dBm)	Limit (dBm)	Margin (dB)	Polarization
3815	-56.65	1.29	3	12.22	-45.72	-13	32.72	H
3815	-55.88	1.29	3	12.22	-44.95	-13	31.95	V
5722.5	-53.74	1.74	3	12.66	-42.82	-13	29.82	H
5722.5	-60.13	1.74	3	12.66	-49.21	-13	36.21	V



*LTE FDD Band 4\_Channel Bandwidth 5MHz\_QPSK\_ Low Channel*

Frequency (MHz)	P <sub>Mea</sub> (dBm)	P <sub>cl</sub> (dB)	Diatance	G <sub>a</sub> Antenna Gain(dB)	Peak EIRP (dBm)	Limit (dBm)	Margin (dB)	Polarization
3425	-53.45	1.2	3	11.82	-42.83	-13	29.83	H
3425	-54.25	1.2	3	11.82	-43.63	-13	30.63	V
5137.5	-50.64	1.6	3	12.37	-39.87	-13	26.87	H
5137.5	-53.22	1.6	3	12.37	-42.45	-13	29.45	V

*LTE FDD Band 4\_Channel Bandwidth 5MHz\_QPSK\_ Middle Channel*

Frequency (MHz)	P <sub>Mea</sub> (dBm)	P <sub>cl</sub> (dB)	Diatance	G <sub>a</sub> Antenna Gain(dB)	Peak EIRP (dBm)	Limit (dBm)	Margin (dB)	Polarization
3465	-56.09	1.21	3	11.86	-45.44	-13	32.44	H
3465	-55.21	1.21	3	11.86	-44.56	-13	31.56	V
5197.5	-47.03	1.61	3	12.4	-36.24	-13	23.24	H
5197.5	-53.11	1.61	3	12.4	-42.32	-13	29.32	V

*LTE FDD Band 4\_Channel Bandwidth 5MHz\_QPSK\_ High Channel*

Frequency (MHz)	P <sub>Mea</sub> (dBm)	P <sub>cl</sub> (dB)	Diatance	G <sub>a</sub> Antenna Gain(dB)	Peak EIRP (dBm)	Limit (dBm)	Margin (dB)	Polarization
3505	-54.46	1.22	3	11.9	-43.78	-13	30.78	H
3505	-55.09	1.22	3	11.9	-44.41	-13	31.41	V
5257.5	-46.81	1.63	3	12.43	-36.01	-13	23.01	H
5257.5	-58.28	1.63	3	12.43	-47.48	-13	34.48	V



*LTE FDD Band 5\_Channel Bandwidth 5MHz\_QPSK\_Low Channel*

Frequency (MHz)	P <sub>Mea</sub> (dBm)	P <sub>cl</sub> (dB)	Diatance	G <sub>a</sub> Antenna Gain(dB)	Peak EIRP (dBm)	Limit (dBm)	Margin (dB)	Polarization
1653	-50.43	0.83	3	8.61	-42.65	-13	29.65	H
1653	-52.58	0.83	3	8.61	-44.80	-13	31.80	V
2479.5	-51.17	1	3	10.72	-41.45	-13	28.45	H
2479.5	-54.07	1	3	10.72	-44.35	-13	31.35	V

*LTE FDD Band 5\_Channel Bandwidth 5MHz\_QPSK\_Middle Channel*

Frequency (MHz)	P <sub>Mea</sub> (dBm)	P <sub>cl</sub> (dB)	Diatance	G <sub>a</sub> Antenna Gain(dB)	Peak EIRP (dBm)	Limit (dBm)	Margin (dB)	Polarization
1673	-53.18	0.83	3	8.69	-45.32	-13	32.32	H
1673	-51.17	0.83	3	8.69	-43.31	-13	30.31	V
2509.5	-51.57	1	3	10.76	-41.81	-13	28.81	H
2509.5	-54.86	1	3	10.76	-45.10	-13	32.10	V

*LTE FDD Band 5\_Channel Bandwidth 5MHz\_QPSK\_High Channel*

Frequency (MHz)	P <sub>Mea</sub> (dBm)	P <sub>cl</sub> (dB)	Diatance	G <sub>a</sub> Antenna Gain(dB)	Peak EIRP (dBm)	Limit (dBm)	Margin (dB)	Polarization
1693	-55.84	0.84	3	8.78	-47.90	-13	34.90	H
1693	-52.10	0.84	3	8.78	-44.16	-13	31.16	V
2539.5	-46.71	1.01	3	10.8	-36.92	-13	23.92	H
2539.5	-52.51	1.01	3	10.8	-42.72	-13	29.72	V



*LTE FDD Band 7\_Channel Bandwidth 5MHz\_QPSK\_Low Channel*

Frequency (MHz)	P <sub>Mea</sub> (dBm)	P <sub>cl</sub> (dB)	Diatance	G <sub>a</sub> Antenna Gain(dB)	Peak EIRP (dBm)	Limit (dBm)	Margin (dB)	Polarization
5005	-52.88	1.57	3	12.3	-42.15	-25	17.15	H
5005	-56.42	1.57	3	12.3	-45.69	-25	20.69	V
7507.5	-47.51	2	3	11.25	-38.26	-25	13.26	H
7507.5	-56.08	2	3	11.25	-46.83	-25	21.83	V

*LTE FDD Band 7\_Channel Bandwidth 5MHz\_QPSK\_Middle Channel*

Frequency (MHz)	P <sub>Mea</sub> (dBm)	P <sub>cl</sub> (dB)	Diatance	G <sub>a</sub> Antenna Gain(dB)	Peak EIRP (dBm)	Limit (dBm)	Margin (dB)	Polarization
5070	-54.79	1.58	3	12.34	-44.03	-25	19.03	H
5070	-57.80	1.58	3	12.34	-47.04	-25	22.04	V
7605	-51.96	2.01	3	11.22	-42.75	-25	17.75	H
7605	-55.29	2.01	3	11.22	-46.08	-25	21.08	V

*LTE FDD Band 7\_Channel Bandwidth 5MHz\_QPSK\_High Channel*

Frequency (MHz)	P <sub>Mea</sub> (dBm)	P <sub>cl</sub> (dB)	Diatance	G <sub>a</sub> Antenna Gain(dB)	Peak EIRP (dBm)	Limit (dBm)	Margin (dB)	Polarization
5135	-56.84	1.6	3	12.37	-46.07	-25	21.07	H
5135	-54.26	1.6	3	12.37	-43.49	-25	18.49	V
7702.5	-47.54	2.03	3	11.19	-38.38	-25	13.38	H
7702.5	-52.15	2.03	3	11.19	-42.99	-25	17.99	V



*LTE TDD Band 38\_Channel Bandwidth 5MHz\_QPSK\_Low Channel*

Frequency (MHz)	P <sub>Mea</sub> (dBm)	P <sub>cl</sub> (dB)	Diatance	G <sub>a</sub> Antenna Gain(dB)	Peak EIRP (dBm)	Limit (dBm)	Margin (dB)	Polarization
5145	-53.25	1.6	3	12.37	-42.48	-25	17.48	H
5145	-53.17	1.6	3	12.37	-42.40	-25	17.40	V
7717.5	-49.07	2.03	3	11.18	-39.92	-25	14.92	H
7717.5	-51.79	2.03	3	11.18	-42.64	-25	17.64	V

*LTE TDD Band 38\_Channel Bandwidth 5MHz\_QPSK\_Middle Channel*

Frequency (MHz)	P <sub>Mea</sub> (dBm)	P <sub>cl</sub> (dB)	Diatance	G <sub>a</sub> Antenna Gain(dB)	Peak EIRP (dBm)	Limit (dBm)	Margin (dB)	Polarization
5190	-54.26	1.61	3	12.4	-43.47	-25	18.47	H
5190	-53.96	1.61	3	12.4	-43.17	-25	18.17	V
7785	-49.25	2.04	3	11.16	-40.13	-25	15.13	H
7785	-58.97	2.04	3	11.16	-49.85	-25	24.85	V

*LTE TDD Band 38\_Channel Bandwidth 5MHz\_QPSK\_High Channel*

Frequency (MHz)	P <sub>Mea</sub> (dBm)	P <sub>cl</sub> (dB)	Diatance	G <sub>a</sub> Antenna Gain(dB)	Peak EIRP (dBm)	Limit (dBm)	Margin (dB)	Polarization
5235	-56.57	1.62	3	12.42	-45.77	-25	20.77	H
5235	-55.16	1.62	3	12.42	-44.36	-25	19.36	V
7852.5	-45.75	2.05	3	11.14	-36.66	-25	11.66	H
7852.5	-57.07	2.05	3	11.14	-47.98	-25	22.98	V



*LTE TDD Band 41\_Channel Bandwidth 5MHz\_QPSK\_Low Channel*

Frequency (MHz)	P <sub>Mea</sub> (dBm)	P <sub>cl</sub> (dB)	Diatance	G <sub>a</sub> Antenna Gain(dB)	Peak EIRP (dBm)	Limit (dBm)	Margin (dB)	Polarization
4997	-53.89	1.57	3	12.3	-43.16	-25	18.16	H
4997	-56.10	1.57	3	12.3	-45.37	-25	20.37	V
7495.5	-46.87	2	3	11.25	-37.62	-25	12.62	H
7495.5	-57.13	2	3	11.25	-47.88	-25	22.88	V

*LTE TDD Band 41\_Channel Bandwidth 5MHz\_QPSK\_Middle Channel*

Frequency (MHz)	P <sub>Mea</sub> (dBm)	P <sub>cl</sub> (dB)	Diatance	G <sub>a</sub> Antenna Gain(dB)	Peak EIRP (dBm)	Limit (dBm)	Margin (dB)	Polarization
5186	-53.10	1.61	3	12.39	-42.32	-25	17.32	H
5186	-55.79	1.61	3	12.39	-45.01	-25	20.01	V
7779	-46.69	2.04	3	11.17	-37.56	-25	12.56	H
7779	-56.35	2.04	3	11.17	-47.22	-25	22.22	V

*LTE TDD Band 41\_Channel Bandwidth 5MHz\_QPSK\_High Channel*

Frequency (MHz)	P <sub>Mea</sub> (dBm)	P <sub>cl</sub> (dB)	Diatance	G <sub>a</sub> Antenna Gain(dB)	Peak EIRP (dBm)	Limit (dBm)	Margin (dB)	Polarization
5375	-58.95	1.65	3	12.49	-48.11	-25	23.11	H
5375	-57.06	1.65	3	12.49	-46.22	-25	21.22	V
8062.5	-46.66	2.08	3	11.14	-37.60	-25	12.60	H
8062.5	-58.60	2.08	3	11.14	-49.54	-25	24.54	V



## 5.6. Frequency Stability under Temperature & Voltage Variations

### 5.6.1. LIMIT

According to FCC §2.1055, §22.355, §24.235 and §27.54 and §90.213 requirement, the frequency stability shall be sufficient to ensure that the fundamental emissions stay within the authorized bands of operation and should not exceed 2.5ppm.

### 5.6.2. TEST CONFIGURATION

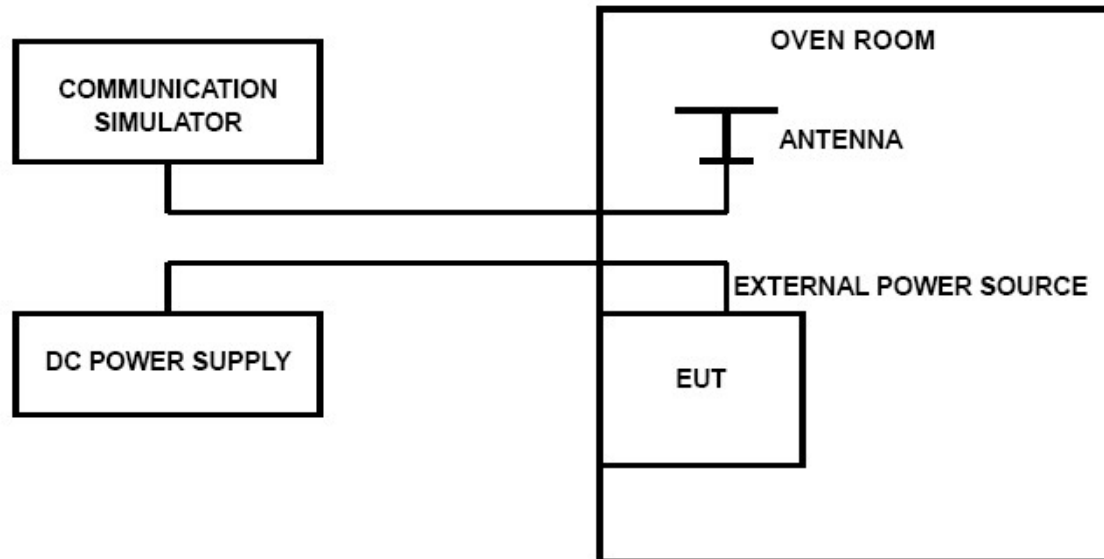

### 5.6.3. TEST PROCEDURE

The EUT was setup according to ANSI C63.26.

### 5.6.4. Frequency Stability Under Temperature Variations:

In order to measure the carrier frequency under the condition of AFC lock, it is necessary to make measurements with the EUT in a “call mode”. This is accomplished with the use of R&S CMW500 DIGITAL RADIO COMMUNICATION TESTER.

1. Measure the carrier frequency at room temperature.
2. Subject the EUT to overnight soak at -30°C.
3. With the EUT, powered via nominal voltage, connected to the CMW500 and in a simulated call on middle channel for Specific band, measure the carrier frequency. These measurements should be made within 2 minutes of Powering up the EUT, to prevent significant self-warming.
4. Repeat the above measurements at 10°C increments from -30°C to +50°C. Allow at least 1.5 hours at each temperature, unpowered, before making measurements.
5. Re-measure carrier frequency at room temperature with nominal voltage. Vary supply voltage from minimum voltage to maximum voltage, in 0.1Volt increments re-measuring carrier frequency at each voltage. Pause at nominal voltage for 1.5 hours unpowered, to allow any self-heating to stabilize, before continuing.
6. Subject the EUT to overnight soak at +50°C.
7. With the EUT, powered via nominal voltage, connected to the CMW500 and in a simulated call on the centre channel, measure the carrier frequency. These measurements should be made within 2 minutes of Powering up the EUT, to prevent significant self-warming.
8. Repeat the above measurements at 10 °C increments from +50°C to -30°C. Allow at least 1.5 hours at each temperature, unpowered, before making measurements
9. At all temperature levels hold the temperature to +/- 0.5°C during the measurement procedure.





#### 5.6.5. Frequency Stability Under Voltage Variations:

Set chamber temperature to 20°C. Use a variable AC power supply / DC power source to power the EUT and set the voltage to rated voltage. Set the spectrum analyzer RBW low enough to obtain the desired frequency resolution and recorded the frequency.

Reduce the input voltage to specify extreme voltage variation ( $\pm 15\%$ ) and endpoint, record the maximum frequency change.

#### 5.6.6. TEST RESULTS

##### Pass

Remark:

1. We tested all RB Configuration refer 3GPP TS136 521 for each Channel Bandwidth as list in section 3.3 of this report, and record the worst case in this report.
2. please refer to Frequency Stability in Appendix Test data for LTE Band2.
3. please refer to Frequency Stability in Appendix Test data for LTE Band4.
4. please refer to Frequency Stability in Appendix Test data for LTE Band5.
5. please refer to Frequency Stability in Appendix Test data for LTE Band7.
6. please refer to Frequency Stability in Appendix Test data for LTE Band38.
7. please refer to Frequency Stability in Appendix Test data for LTE Band41.



## **6. TEST SETUP PHOTOS OF THE EUT**

Please refer to separated files for Test Setup Photos of the EUT.

## **7. EXTERNAL PHOTOS OF THE EUT**

Please refer to separated files for External Photos of the EUT.

## **8. INTERNAL PHOTOS OF THE EUT**

Please refer to separated files for Internal Photos of the EUT.

-----THE END OF REPORT-----