



TEST REPORT

FCC ID:2BK5W-YMP-A1

Report Number.....: **ZKT-240913L11618E-1**
Date of Test..... Sep. 07, 2024-Sep. 19, 2024
Date of issue.....: Sep. 25, 2024
Total number of pages..... 40
Test Result: **PASS**

Testing Laboratory.....: Shenzhen ZKT Technology Co., Ltd.
Address: 1/F, No. 101, Building B, No. 6, Tangwei Community Industrial Avenue, Fuhai Street, Bao'an District, Shenzhen, China

Applicant's name: Shenzhen Huiran Technology Co., Ltd
Address: Room 403, Block C, Zhantao Building, Minzhi Avenue Longhua New District, Shenzhen

Manufacturer's name: Shenzhen Huiran Technology Co., Ltd
Address: Room 403, Block C, Zhantao Building, Minzhi Avenue Longhua New District, Shenzhen

Test specification:
Standard.....: FCC CFR Title 47 Part 15 Subpart C Section 15.247
ANSI C63.10:2013
Test procedure.....: /
Non-standard test method: N/A

Test Report Form No.....: TRF-EL-112_V0
Test Report Form(s) Originator.....: ZKT Testing
Master TRF: Dated: 2021-04-22

This device described above has been tested by ZKT, and the test results show that the equipment under test (EUT) is in compliance with the FCC requirements. And it is applicable only to the tested sample identified in the report.
This report shall not be reproduced except in full, without the written approval of ZKT, this document may be altered or revised by ZKT, personal only, and shall be noted in the revision of the document.

Product name.....: MP4 Player
Trademark: YFFIZQ
Model/Type reference.....: YMP-A1, YMP-A2, YMP-A3, YMP-A4, YMP-A5, YMP-M1, YMP-M2, YMP-M3, YMP-M5, YMP-M7, YMP-M9, CRP-Z1, CRP-Z2, CRP-Z3, CRP.Z4, CRP-Z5, CRP-W1, CRP-W5, CRP-W7, CRP-W9, CRP-W10, YMP-F1, YMP-F2, YMP-F3, YMP-F4, YMP-F5, YMP-H1, YMP-H2, YMP-H3, YMP-H4, YMP-H5, M8, M9-TP-01, M9-TP-02, M9-TP-03, M9-TP-04, M9-TP-05, M9-LT01, M9-LT-02, M9-LT-03, M9-LT-04, M9-LT-05, TWR-01, TWR-02, TWR-03, TWR-04, TWR-05, YSF-S1, YSF-S2
Ratings.....: DC 5V form Adapter input AC 120V/60Hz or Battery 3.7V



Testing procedure and testing location:

Testing Laboratory.....: Shenzhen ZKT Technology Co., Ltd.

Address.....: 1/F, No. 101, Building B, No. 6, Tangwei Community Industrial Avenue, Fuhai Street, Bao'an District, Shenzhen, China

Tested by (name + signature).....: Jim Liu

Reviewer (name + signature).....: Jackson Fang

Approved (name + signature).....: Lake Xie





Table of Contents

	Page
1. VERSION	5
2. TEST SUMMARY	6
2.1 TEST FACILITY	7
2.2 MEASUREMENT UNCERTAINTY	7
3. GENERAL INFORMATION	8
3.1 GENERAL DESCRIPTION OF EUT	8
3.2 Test Setup Configuration	10
3.3 Support Equipment	10
3.4 Test Mode	11
3.5 EQUIPMENTS LIST FOR ALL TEST ITEMS	12
4. EMC EMISSION TEST	14
4.1 Conducted emissions	14
4.1.1 POWER LINE CONDUCTED EMISSION Limits	14
4.1.2 TEST PROCEDURE	14
4.1.3 DEVIATION FROM TEST STANDARD	14
4.1.5 EUT OPERATING CONDITIONS	15
4.1.6 Test Result	16
4.2 Radiated emissions	18
4.2.1 Radiated Emission Limits	18
4.2.2 TEST PROCEDURE	18
4.2.3 DEVIATION FROM TEST STANDARD	19
4.2.4 TEST SETUP	19
4.2.5 EUT OPERATING CONDITIONS	20
4.2.6 TEST RESULTS	20
5. RADIATED BAND EMISSION MEASUREMENT	29
5.1 Test Requirement:	29
5.2 TEST PROCEDURE	29
5.3 DEVIATION FROM TEST STANDARD	30
5.4 TEST SETUP	30
5.5 EUT OPERATING CONDITIONS	30
5.6 TEST RESULT	31
6. CONDUCTED BAND EDGE AND SPURIOUS EMISSION	33
6.1 Limit	33
6.2 Test Setup	33
6.3 Test procedure	33
6.4 DEVIATION FROM STANDARD	33
6.5 Test Result	33
7. 20DB BANDWIDTH & 99% OCCUPIED BANDWIDTH	34
7.1 Test Setup	34
7.2 Limit	34
7.3 Test procedure	34
7.4 DEVIATION FROM STANDARD	34
7.5 Test Result	34



8. MAXIMUM PEAK OUTPUT POWER	35
8.1 Block Diagram Of Test Setup.....	35
8.2 Limit.....	35
8.3 Test procedure.....	35
8.4 DEVIATION FROM STANDARD.....	35
8.5 Test Result.....	35
9. HOPPING CHANNEL SEPARATION	36
9.1 Test Setup.....	36
9.2 Test procedure.....	36
9.3 DEVIATION FROM STANDARD.....	36
9.4 Test Result.....	36
10. NUMBER OF HOPPING FREQUENCY	37
10.1 Test Setup.....	37
10.2 Test procedure.....	37
10.3 DEVIATION FROM STANDARD.....	37
10.4 Test Result.....	37
11. DWELL TIME	38
11.1 Test Setup.....	38
11.2 Test procedure.....	38
11.3 DEVIATION FROM STANDARD.....	38
11.4 Test Result.....	38
13. TEST SETUP PHOTO	40
14. EUT CONSTRUCTIONAL DETAILS	40



1. VERSION

Report No.	Version	Description	Approved
ZKT-240913L11618E-1	Rev.01	Initial issue of report	Sep. 25, 2024



2. TEST SUMMARY

Test procedures according to the technical standards:

FCC Part15 (15.247) , Subpart C			
Standard Section	Test Item	Result	Remark
15.203	Antenna Requirement	PASS	
15.207	AC Power Line Conducted Emission	PASS	
15.247 (b)(1)	Conducted Peak Output Power	PASS	
15.247 (a)(1)	20 dB Bandwidth & 99% Occupied Bandwidth	PASS	
15.247 (a)(1)	Carrier Frequencies Separation	PASS	
15.247 (a)(1)(iii)	Hopping Channel Number	PASS	
15.247 (a)(1)(iii)	Dwell Time	PASS	
15.205/15.209	Radiated Emission and Restricted Band	PASS	
15.247(d)	Conducted Unwanted emissions and Band Edge	PASS	

NOTE:

(1) "N/A" denotes test is not applicable in this Test Report



2.1 TEST FACILITY

Shenzhen ZKT Technology Co., Ltd.
Add. : 1/F, No. 101, Building B, No. 6, Tangwei Community Industrial Avenue, Fuhai Street,
Bao'an District, Shenzhen, China

FCC Test Firm Registration Number: 692225
Designation Number: CN1299
IC Registered No.: 27033
CAB identifier: CN0110
Designation Number: CN0110

2.2 MEASUREMENT UNCERTAINTY

The reported uncertainty of measurement $y \pm U$, where expanded uncertainty U is based on a standard uncertainty multiplied by a coverage factor of $k=2$, providing a level of confidence of approximately 95 %.

No.	Item	Uncertainty
1	3m chamber Radiated spurious emission(9KHz-30MHz)	U=4.5dB
2	3m chamber Radiated spurious emission(30MHz-1GHz)	U=4.8dB
3	3m chamber Radiated spurious emission(1GHz-6GHz)	U=4.9dB
4	3m chamber Radiated spurious emission(6GHz-40GHz)	U=5.0dB
5	Conducted disturbance	U=3.2dB
6	RF Band Edge	U=1.68dB
7	RF power conducted	U=1.86dB
8	RF conducted Spurious Emission	U=2.2dB
9	RF Occupied Bandwidth	U=1.8MHz
10	humidity uncertainty	U=5.3%
11	Temperature uncertainty	U=0.59°C



3. GENERAL INFORMATION

3.1 GENERAL DESCRIPTION OF EUT

Product Name:	MP4 Player
Model No.:	YMP-A1, YMP-A2, YMP-A3, YMP-A4, YMP-A5, YMP-M1, YMP-M2, YMP-M3, YMP-M5, YMP-M7, YMP-M9, CRP-Z1, CRP-Z2, CRP-Z3, CRP.Z4, CRP-Z5, CRP-W1, CRP-W5, CRP-W7, CRP-W9, CRP-W10, YMP-F1, YMP-F2, YMP-F3, YMP-F4, YMP-F5, YMP-H1, YMP-H2, YMP-H3, YMP-H4, YMP-H5, M8, M9-TP-01, M9-TP-02, M9-TP-03, M9-TP-04, M9-TP-05, M9-LT01, M9-LT-02, M9-LT-03, M9-LT-04, M9-LT-05, TWR-01, TWR-02, TWR-03, TWR-04, TWR-05, YSF-S1, YSF-S2
Model difference:	All models are only different in color
Test sample(s) ID:	ZKT-240913L11618-1
Sample(s) Status:	Engineer sample
Hardware Version:	V2
Software Version:	V1.0
Channel numbers:	79
Channel separation:	2402MHz~2480MHz
Modulation technology:	GFSK, $\pi/4$ -DQPSK, 8DPSK
Antenna Type:	FPC Antenna
Antenna gain:	0.25 dBi
Power supply:	DC 5V form Adapter input AC 120V/60Hz or Battery 3.7V



Operation Frequency each of channel							
Channel	Frequency	Channel	Frequency	Channel	Frequency	Channel	Frequency
0	2402MHz	20	2422MHz	40	2442MHz	60	2462MHz
1	2403MHz	21	2423MHz	41	2443MHz	61	2463MHz
2	2404MHz	22	2424MHz	42	2444MHz	62	2464MHz
3	2405MHz	23	2425MHz	43	2445MHz	63	2465MHz
4	2406MHz	24	2426MHz	44	2446MHz	64	2466MHz
5	2407MHz	25	2427MHz	45	2447MHz	65	2467MHz
6	2408MHz	26	2428MHz	46	2448MHz	66	2468MHz
7	2409MHz	27	2429MHz	47	2449MHz	67	2469MHz
8	2410MHz	28	2430MHz	48	2450MHz	68	2470MHz
9	2411MHz	29	2431MHz	49	2451MHz	69	2471MHz
10	2412MHz	30	2432MHz	50	2452MHz	70	2472MHz
11	2413MHz	31	2433MHz	51	2453MHz	71	2473MHz
12	2414MHz	32	2434MHz	52	2454MHz	72	2474MHz
13	2415MHz	33	2435MHz	53	2455MHz	73	2475MHz
14	2416MHz	34	2436MHz	54	2456MHz	74	2476MHz
15	2417MHz	35	2437MHz	55	2457MHz	75	2477MHz
16	2418MHz	36	2438MHz	56	2458MHz	76	2478MHz
17	2419MHz	37	2439MHz	57	2459MHz	77	2479MHz
18	2420MHz	38	2440MHz	58	2460MHz	78	2480MHz
19	2421MHz	39	2441MHz	59	2461MHz		

Note:

In section 15.31(m), regards to the operating frequency range over 10 MHz, the Lowest frequency, the middle frequency, and the highest frequency of channel were selected to perform the test, and the selected channel see below:

Test channel	Frequency
The lowest channel	2402MHz
The middle channel	2441MHz
The Highest channel	2480MHz



3.2 Test Setup Configuration

Conducted Emission

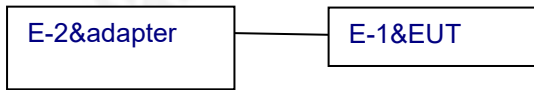

Radiated Emission



Conducted Spurious

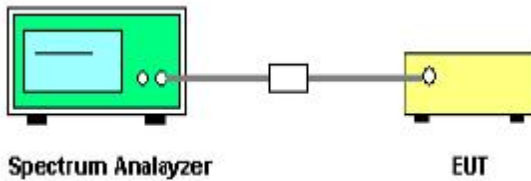

3.3 Support Equipment

The EUT has been tested as an independent unit together with other necessary accessories or support units. The following support units or accessories were used to form a representative test configuration during the tests.

Item	Equipment	Mfr/Brand	Model/Type No.	Series No.	Note
E-1	MP4 Player	YFFIZQ	YMP-A1	N/A	EUT
E-2	Power adapter	/	/	N/A	AE

Item	Shielded Type	Ferrite Core	Length	Note

Note:

- (1) The support equipment was authorized by Declaration of Confirmation.
- (2) For detachable type I/O cable should be specified the length in cm in 『Length』 column.
- (3) “YES” is means “shielded” “with core”; “NO” is means “unshielded” “without core”.



3.4 Test Mode

Transmitting mode	Keep the EUT in continuously transmitting mode.
Remark: During the test, the test voltage was tuned from 85% to 115% of the nominal rated supply voltage, and found that the worst case was under the nominal rated supply condition. So the report just shows that condition's data.	

Operating mode	
Test mode 1	MP4 playing
Test mode 2	Bluetooth
Test mode 3	PC data transmitting

Test Software	BT Test Tool
Power level setup	Default



3.5 EQUIPMENTS LIST FOR ALL TEST ITEMS

Radiation Test equipment

Item	Equipment	Manufacturer	Type No.	Serial No.	Firmware Version	Last calibration	Calibrated until
1	Spectrum Analyzer (9kHz-26.5GHz)	KEYSIGHT	9020A	MY55370835	A.17.05	Nov. 02, 2023	Nov. 01, 2024
2	Spectrum Analyzer (10kHz-39.9GHz)	R&S	FSV40-N	100363	1.71 SP2	Nov. 02, 2023	Nov. 01, 2024
3	EMI Test Receiver (9kHz-7GHz)	R&S	ESCI7	100969	4.32	Nov. 02, 2023	Nov. 01, 2024
4	Bilog Antenna (30MHz-1500MHz)	Schwarzbeck	VULB9168	N/A	N/A	Nov. 13, 2023	Nov. 12, 2024
5	Horn Antenna (1GHz-18GHz)	Agilent	AH-118	071145	N/A	Nov. 13, 2023	Nov. 12, 2024
6	Horn Antenna (15GHz-40GHz)	A.H.System	SAS-574	588	N/A	Nov. 13, 2023	Nov. 12, 2024
7	Loop Antenna	TESEQ	HLA6121	58357	N/A	Nov. 16, 2023	Nov. 15, 2024
8	Amplifier (30-1000MHz)	EM Electronics	EM330 Amplifier	60747	N/A	Nov. 02, 2023	Nov. 01, 2024
9	Amplifier (1GHz-26.5GHz)	HuiPu	8449B	3008A00315	N/A	Nov. 02, 2023	Nov. 01, 2024
10	Amplifier (500MHz-40GHz)	QuanJuDa	DLE-161	097	N/A	Nov. 02, 2023	Nov. 01, 2024
11	Test Cable	N/A	R-01	N/A	N/A	Nov. 02, 2023	Nov. 01, 2024
12	Test Cable	N/A	R-02	N/A	N/A	Nov. 02, 2023	Nov. 01, 2024
13	Test Cable	N/A	R-03	N/A	N/A	Nov. 02, 2023	Nov. 01, 2024
14	Test Cable	N/A	RF-01	N/A	N/A	Nov. 02, 2023	Nov. 01, 2024
15	Test Cable	N/A	RF-02	N/A	N/A	Nov. 02, 2023	Nov. 01, 2024
16	Test Cable	N/A	RF-03	N/A	N/A	Nov. 02, 2023	Nov. 01, 2024
17	ESG Signal Generator	Agilent	E4421B	N/A	B.03.84	Nov. 02, 2023	Nov. 01, 2024
18	Signal Generator	Agilent	N5182A	N/A	A.01.87	Nov. 02, 2023	Nov. 01, 2024
19	Magnetic Field Probe Tester	Narda	ELT-400	0-0344	N/A	Nov. 16, 2023	Nov. 15, 2024
20	Wideband Radio Communication Test	R&S	CMW500	106504	V 3.7.22	Nov. 02, 2023	Nov. 01, 2024
21	MWRF Power Meter Test system	MW	MW100-RF CB	N/A	N/A	Nov. 02, 2023	Nov. 01, 2024
22	D.C. Power Supply	LongWei	TPR-6405D	N/A	N/A	\	\
23	EMC Software	Frad	EZ-EMC	Ver.EMC-CO N 3A1.1	N/A	\	\
24	RF Software	MW	MTS8310	V2.0.0.0	N/A	\	\
25	Turntable	MF	MF-7802BS	N/A	N/A	\	\
26	Antenna tower	MF	MF-7802BS	N/A	N/A	\	\



Conduction Test equipment

Item	Kind of Equipment	Manufacturer	Type No.	Serial No.	Firmware Version	Last calibration	Calibrated until
1	LISN	R&S	ENV216	101471	N/A	Nov. 14, 2023	Nov. 13, 2024
2	LISN	CYBERTEK	EM5040A	E1850400149	N/A	Nov. 02, 2023	Nov. 01, 2024
3	Test Cable	N/A	C-01	N/A	N/A	Nov. 02, 2023	Nov. 01, 2024
4	Test Cable	N/A	C-02	N/A	N/A	Nov. 02, 2023	Nov. 01, 2024
5	Test Cable	N/A	C-03	N/A	N/A	Nov. 02, 2023	Nov. 01, 2024
6	EMI Test Receiver	R&S	ESCI3	101393	4.42 SP3	Nov. 02, 2023	Nov. 01, 2024
7	Triple-Loop Antenna	N/A	RF300	N/A	N/A	Nov. 02, 2023	Nov. 01, 2024
8	Absorbing Clamp	DZ	ZN23201	15034	N/A	Nov. 07, 2023	Nov. 06, 2024
9	EMC Software	Frad	EZ-EMC	Ver.EMC-CON 3A1.1	N/A	\	\



4. EMC EMISSION TEST

4.1 Conducted emissions

Test Requirement:	FCC Part15 C Section 15.207
Test Method:	ANSI C63.10:2013
Test Frequency Range:	150KHz to 30MHz
Receiver setup:	RBW=9KHz, VBW=30KHz, Sweep time=auto

4.1.1 POWER LINE CONDUCTED EMISSION Limits

FREQUENCY (MHz)	Limit (dBuV)		Standard
	Quasi-peak	Average	
0.15 -0.5	66 - 56 *	56 - 46 *	FCC
0.50 -5.0	56.00	46.00	FCC
5.0 -30.0	60.00	50.00	FCC

Note:

(1) *Decreases with the logarithm of the frequency.

4.1.2 TEST PROCEDURE

- a. The EUT was placed 0.1 meters from the horizontal ground plane with EUT being connected to the power mains through a line impedance stabilization network (LISN). All other support equipments powered from additional LISN(s). The LISN provide 50 Ohm/ 50uH of coupling impedance for the measuring instrument.
- b. Interconnecting cables that hang closer than 40 cm to the ground plane shall be folded back and forth in the center forming a bundle 30 to 40 cm long.
- c. I/O cables that are not connected to a peripheral shall be bundled in the center. The end of the cable may be terminated, if required, using the correct terminating impedance. The overall length shall not exceed 1 m.
- d. LISN at least 80 cm from nearest part of EUT chassis.
- e. For the actual test configuration, please refer to the related Item –EUT Test Photos.

4.1.3 DEVIATION FROM TEST STANDARD

No deviation



4.1.4 TEST SETUP

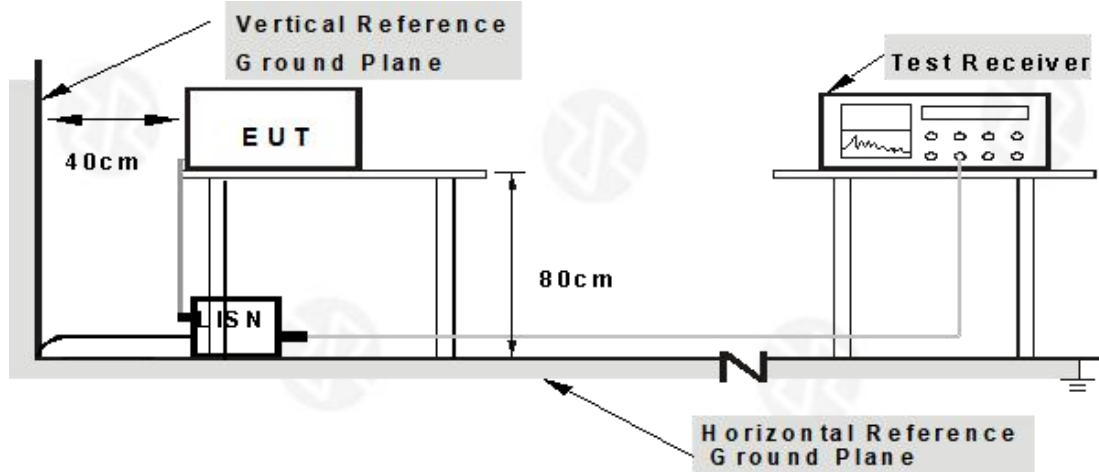

Note: 1.Support units were connected to second LISN.

2.Both of LISNs (AMN) are 80 cm from EUT and at least 80 from other units and other metal planes

4.1.5 EUT OPERATING CONDITIONS

The EUT was configured for testing in a typical fashion (as a customer would normally use it). The EUT has been programmed to continuously transmit during test. This operating condition was tested and used to collect the included data.



4.1.6 Test Result

Temperature:	26°C	Relative Humidity:	54%
Pressure:	101kPa	Phase :	L
Test Voltage :	AC 120V/60Hz	Test Mode :	TX GFSK-2402MHz

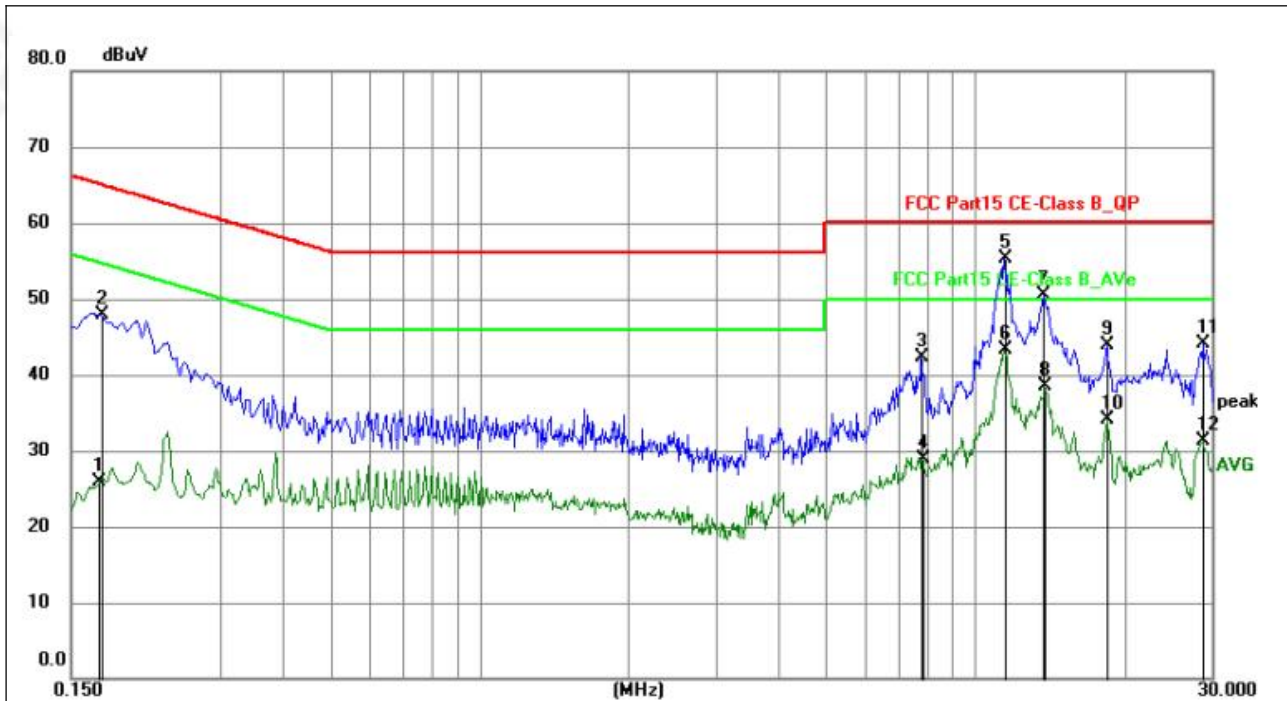

No.	Frequency (MHz)	Reading (dBuV)	Factor (dB)	Level (dBuV)	Limit (dBuV)	Margin (dB)	Detector	P/F
1	0.1711	5.07	20.93	26.00	54.91	-28.91	AVG	P
2	0.1724	27.05	20.94	47.99	64.84	-16.85	QP	P
3	7.7954	20.78	21.59	42.37	60.00	-17.63	QP	P
4	7.8360	7.37	21.60	28.97	50.00	-21.03	AVG	P
5	11.4764	33.03	22.29	55.32	60.00	-4.68	QP	P
6	11.4764	20.94	22.29	43.23	50.00	-6.77	AVG	P
7	13.7129	27.86	22.66	50.52	60.00	-9.48	QP	P
8	13.8074	15.91	22.68	38.59	50.00	-11.41	AVG	P
9	18.5234	20.45	23.46	43.91	60.00	-16.09	QP	P
10	18.5234	10.74	23.46	34.20	50.00	-15.80	AVG	P
11	28.8150	18.96	25.13	44.09	60.00	-15.91	QP	P
12	28.8150	6.23	25.13	31.36	50.00	-18.64	AVG	P

Notes:

1. An initial pre-scan was performed on the line and neutral lines with peak detector.
2. Quasi-Peak and Average measurement were performed at the frequencies with maximized peak emission.
3. Measurement Level = Reading level + Correct Factor
4. The test data shows only the worst case GFSK-2402MHz.



Temperature:	26°C	Relative Humidity:	54%
Pressure:	101kPa	Phase :	N
Test Voltage :	AC 120V/60Hz	Test Mode :	TX GFSK-2402MHz

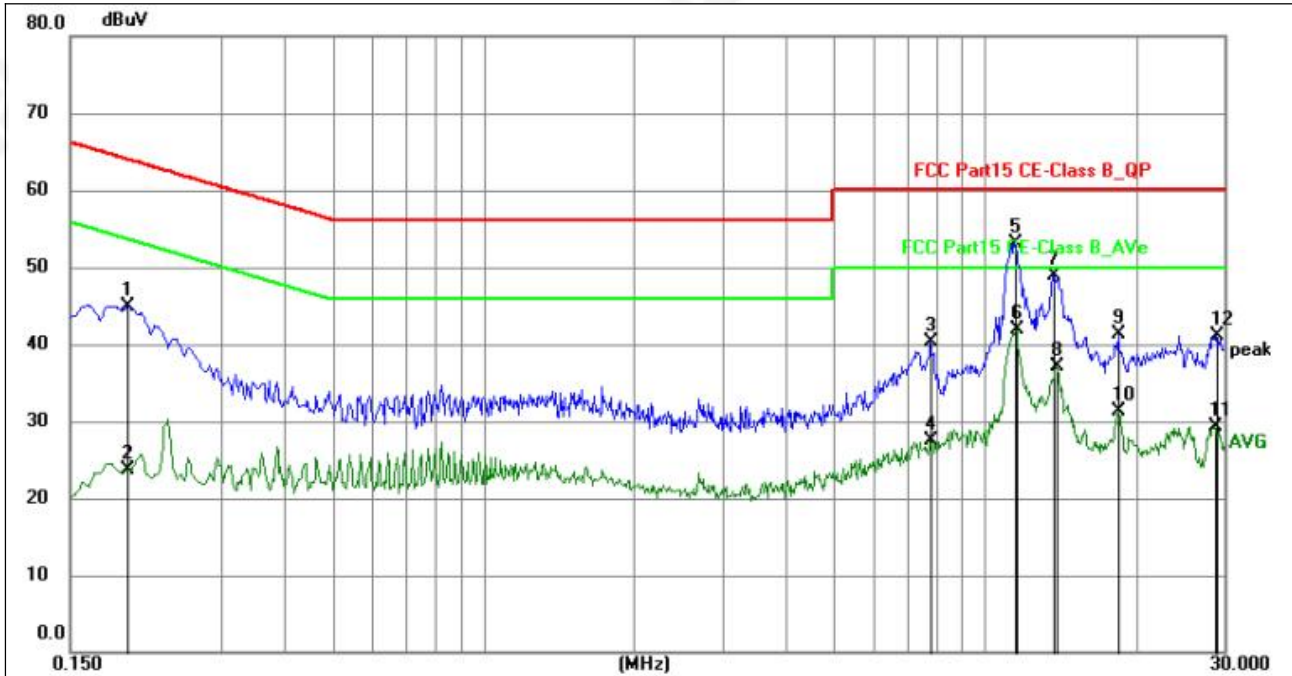

No.	Frequency (MHz)	Reading (dBuV)	Factor (dB)	Level (dBuV)	Limit (dBuV)	Margin (dB)	Detector	P/F
1	0.1949	23.87	20.99	44.86	63.83	-18.97	QP	P
2	0.1952	2.72	20.99	23.71	53.81	-30.10	AVG	P
3	7.8000	18.58	21.69	40.27	60.00	-19.73	QP	P
4	7.8000	5.72	21.69	27.41	50.00	-22.59	AVG	P
5	11.4945	30.72	22.31	53.03	60.00	-6.97	QP	P
6	11.5619	19.57	22.32	41.89	50.00	-8.11	AVG	P
7	13.6950	26.16	22.68	48.84	60.00	-11.16	QP	P
8	13.8524	14.40	22.72	37.12	50.00	-12.88	AVG	P
9	18.4875	17.84	23.51	41.35	60.00	-18.65	QP	P
10	18.4875	7.80	23.51	31.31	50.00	-18.69	AVG	P
11	28.7295	4.18	25.14	29.32	50.00	-20.68	AVG	P
12	28.9185	16.00	25.16	41.16	60.00	-18.84	QP	P

Notes:

1. An initial pre-scan was performed on the line and neutral lines with peak detector.
2. Quasi-Peak and Average measurement were performed at the frequencies with maximized peak emission.
3. Measurement Level = Reading level + Correct Factor
4. The test data shows only the worst case GFSK-2402MHz.



4.2 Radiated emissions

Test Requirement:	FCC Part15 C Section 15.209				
Test Method:	ANSI C63.10:2013				
Test Frequency Range:	9kHz to 25GHz				
Test site:	Measurement Distance: 3m				
Receiver setup:	Frequency	Detector	RBW	VBW	Value
	9KHz-150KHz	Quasi-peak	200Hz	600Hz	Quasi-peak
	150KHz-30MHz	Quasi-peak	9KHz	30KHz	Quasi-peak
	30MHz-1GHz	Quasi-peak	100KHz	300KHz	Quasi-peak
	Above 1GHz	Peak	1MHz	3MHz	Peak
		Peak	1MHz	10Hz	Average

4.2.1 Radiated Emission Limits

Frequencies (MHz)	Field Strength (micovolts/meter)	Measurement Distance (meters)
0.009~0.490	2400/F(KHz)	300
0.490~1.705	24000/F(KHz)	30
1.705~30.0	30	30
30~88	100	3
88~216	150	3
216~960	200	3
Above 960	500	3

LIMITS OF RADIATED EMISSION MEASUREMENT

FREQUENCY (MHz)	Limit (dBuV/m) (at 3M)	
	PEAK	AVERAGE
Above 1000	74	54

Notes:

- (1) The limit for radiated test was performed according to FCC PART 15C.
- (2) The tighter limit applies at the band edges.
- (3) Emission level (dBuV/m)=20log Emission level (uV/m).

4.2.2 TEST PROCEDURE

Below 1GHz test procedure as below:

- a. The EUT was placed on the top of a rotating table 0.8 meters above the ground at a 3 meter semi-anechoic chamber. The table was rotated 360 degrees to determine the position of the highest radiation.
- b. The EUT was set 3 meters away from the interference-receiving antenna, which was mounted on the top of a variable-height antenna tower.
- c. The antenna height is varied from one meter to four meters above the ground to determine the maximum value of the field strength. Both horizontal and vertical polarizations of the antenna are set to make the measurement.



- d. For each suspected emission, the EUT was arranged to its worst case and then the antenna was tuned to heights from 1 meter to 4 meters (for the test frequency of below 30MHz, the antenna was tuned to heights 1 meter) and the rotatable table was turned from 0 degrees to 360 degrees to find the maximum reading.
- e. The test-receiver system was set to Peak Detect Function and Specified Bandwidth with Maximum Hold Mode.
- f. If the emission level of the EUT in peak mode was 10dB lower than the limit specified, then testing could be stopped and the peak values of the EUT would be reported. Otherwise the emissions that did not have 10dB margin would be re-tested one by one using peak, quasi-peak or average method as specified and then reported in a data sheet.

Above 1GHz test procedure as below:

- g. Different between above is the test site, change from Semi- Anechoic Chamber to fully Anechoic Chamber and change form table 0.8 metre to 1.5 metre(Above 18GHz the distance is 1 meter and table is 1.5 metre).
- h. Test the EUT in the lowest channel ,the middle channel ,the Highest channel

Note:

Both horizontal and vertical antenna polarities were tested and performed pretest to three orthogonal axis. The worst case emissions were reported

4.2.3 DEVIATION FROM TEST STANDARD

No deviation

4.2.4 TEST SETUP

(A) Radiated Emission Test-Up Frequency Below 30MHz

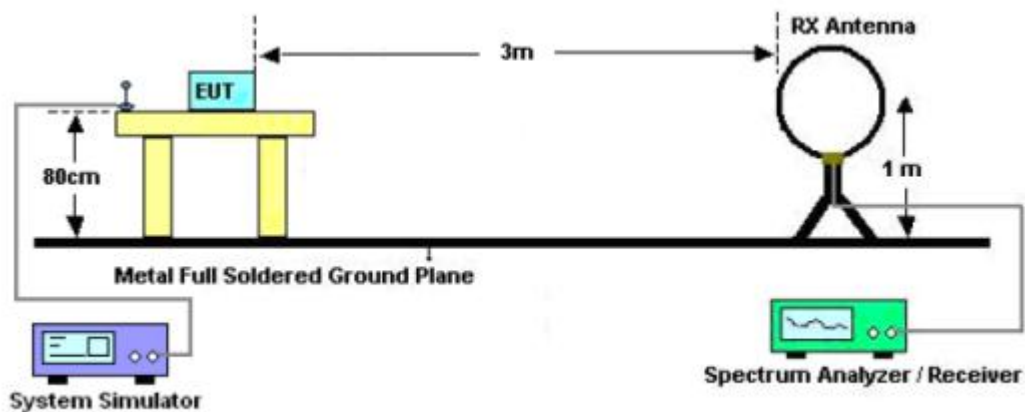



(B) Radiated Emission Test-Up Frequency 30MHz~1GHz

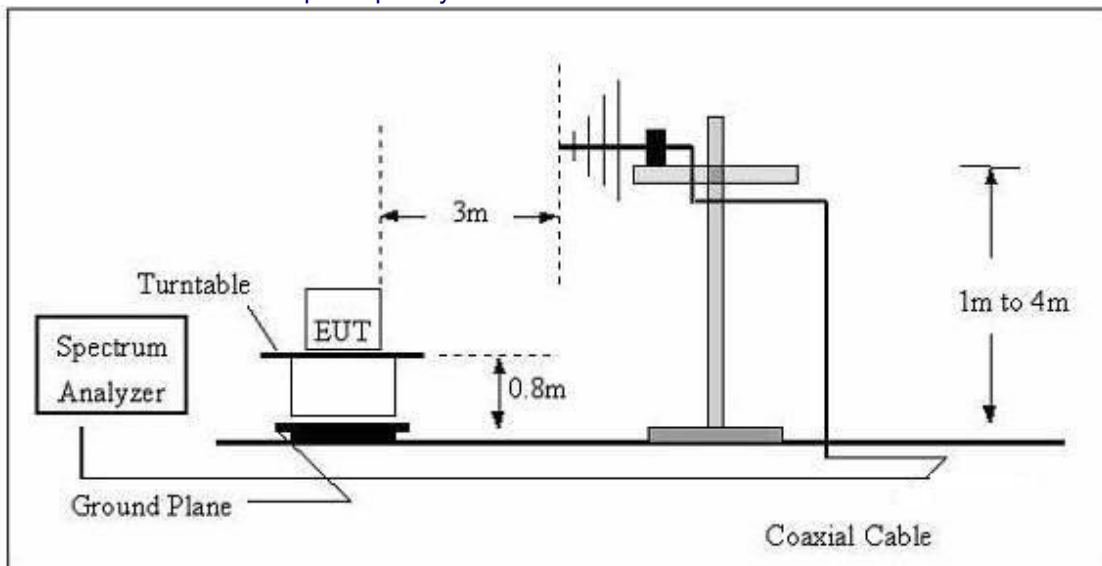

(C) Radiated Emission Test-Up Frequency Above 1GHz

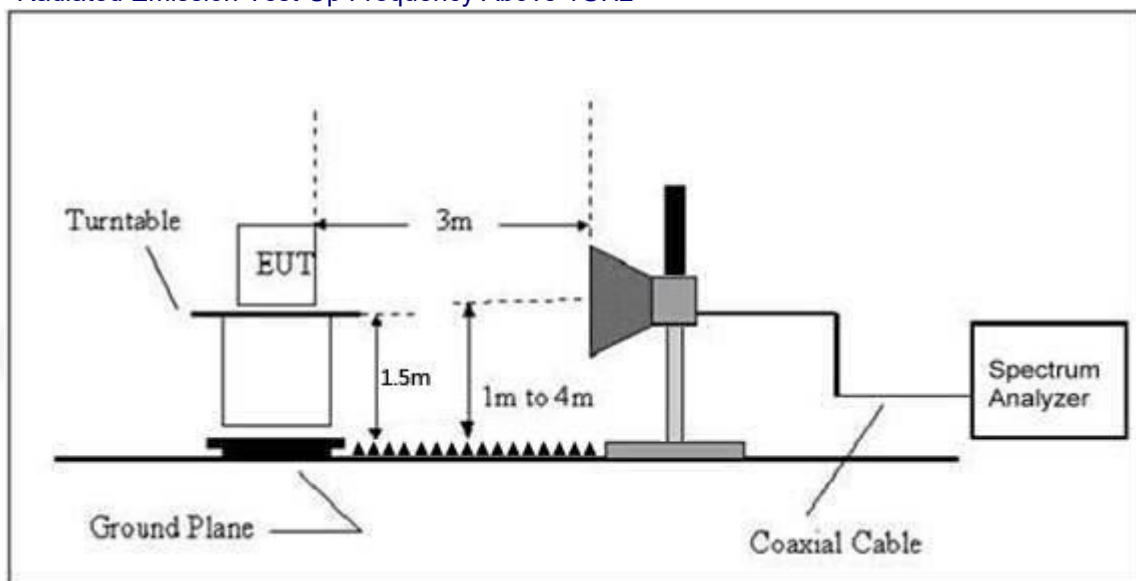

4.2.5 EUT OPERATING CONDITIONS

The EUT tested system was configured as the statements of 2.4 Unless otherwise a special operating condition is specified in the follows during the testing.

4.2.6 TEST RESULTS

Between 9KHz – 30MHz

The emission from 9 kHz to 30MHz was pre-tested and found the result was 20dB lower than the limit, and according to 15.31(o) & RSS-Gen 6.13, the test result no need to reported.



Between 30MHz – 1GHz

Temperature:	26°C	Relative Humidity:	54%
Pressure:	101 kPa	Polarization:	Horizontal
Test Voltage:	AC 120V/60Hz		

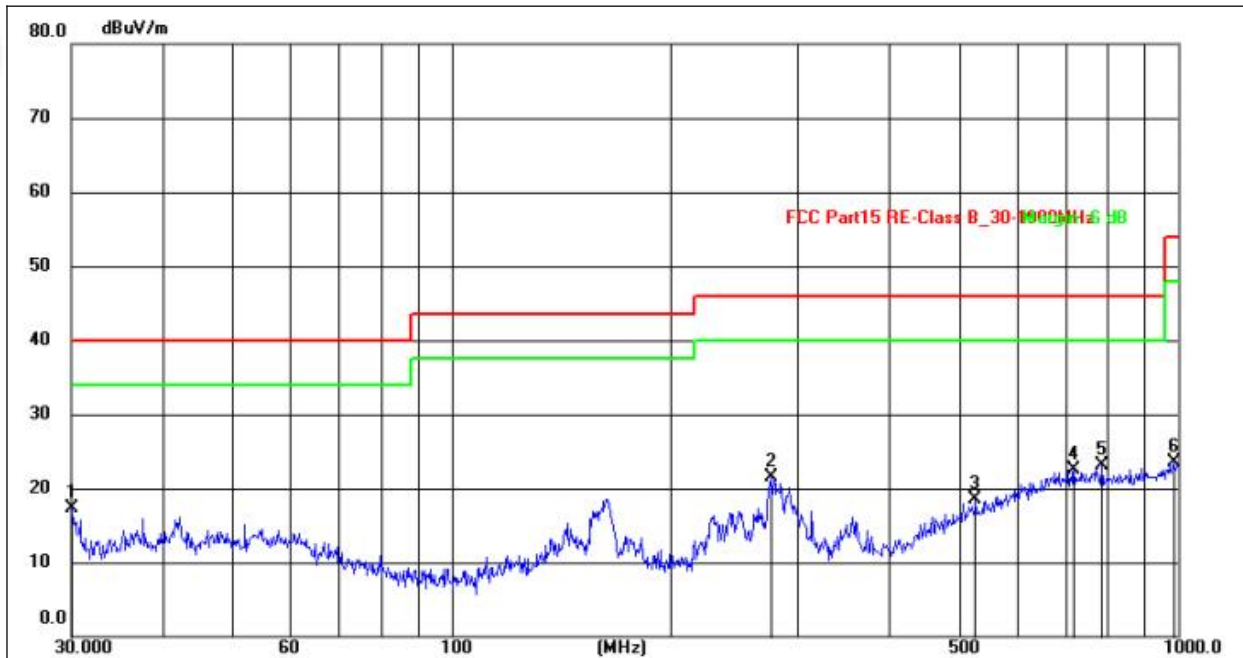

No.	Frequency (MHz)	Reading (dBuV)	Factor (dB/m)	Level (dBuV/m)	Limit (dBuV/m)	Margin (dB)	Detector
1	30.1052	31.46	-14.23	17.23	40.00	-22.77	QP
2	275.1569	36.20	-14.64	21.56	46.00	-24.44	QP
3	526.3967	29.33	-10.88	18.45	46.00	-27.55	QP
4	719.1994	29.33	-6.76	22.57	46.00	-23.43	QP
5	785.0933	30.10	-6.92	23.18	46.00	-22.82	QP
6	986.0715	28.59	-5.17	23.42	54.00	-30.58	QP



Temperature:	26°C	Relative Humidity:	54%
Pressure:	101kPa	Polarization:	Vertical
Test Voltage:	AC 120V/60Hz		

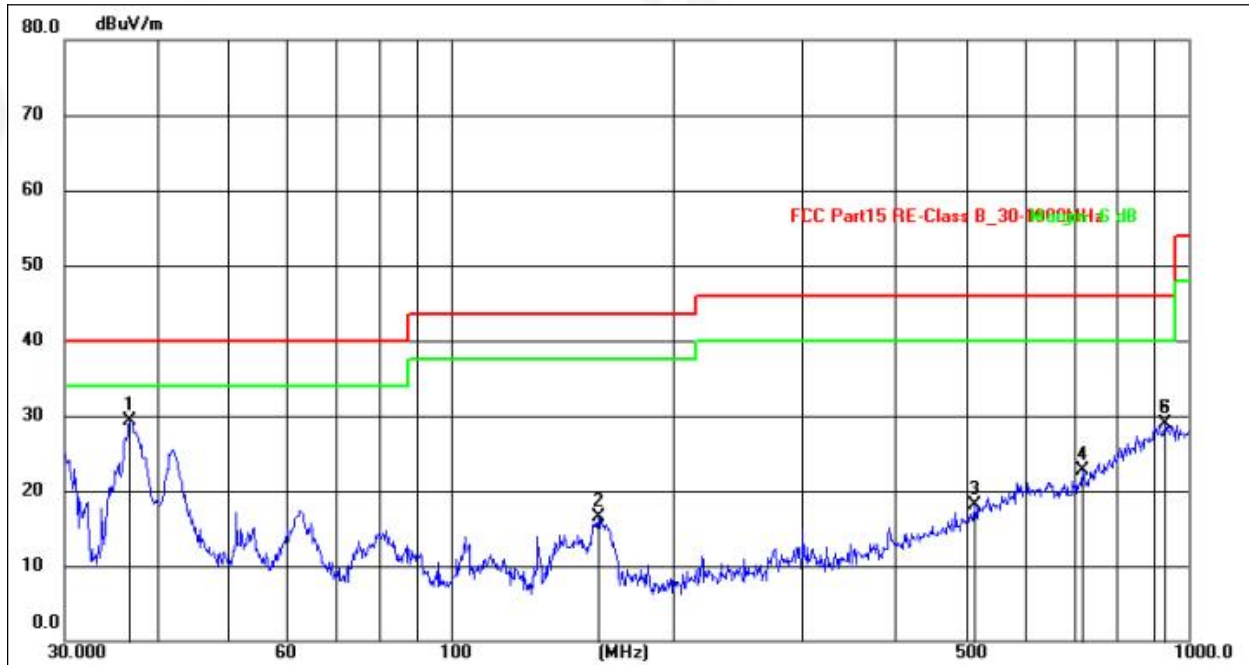

No.	Frequency (MHz)	Reading (dBuV)	Factor (dB/m)	Level (dBuV/m)	Limit (dBuV/m)	Margin (dB)	Detector
1	36.7661	46.69	-17.34	29.35	40.00	-10.65	QP
2	158.6676	36.80	-20.24	16.56	43.50	-26.94	QP
3	513.6331	29.11	-11.05	18.06	46.00	-27.94	QP
4	719.1994	29.54	-6.87	22.67	46.00	-23.33	QP
5	929.0081	29.54	-0.58	28.96	46.00	-17.04	QP
6	929.0081	29.54	-0.58	28.96	46.00	-17.04	QP

Notes:

1. The EUT was test at 3m in field chamber.
2. Final Level =Receiver Read level +Antenna Factor
3. The emission levels of other frequencies are very lower than the limit and not show in test report.



1GHz~25GHz

Polar (H/V)	Frequency	Meter Reading	Pre-amplifier	Cable Loss	Antenna Factor	Emission Level	Limits	Margin	Detector Type
	(MHz)	(dBuV)	(dB)	(dB)	(dB)	(dBuV/m)	(dBuV/m)	(dB)	
Low Channel:2402MHz									
V	4804.00	54.83	30.55	5.77	24.66	54.71	74.00	-19.29	Pk
V	4804.00	45.18	30.55	5.77	24.66	45.06	54.00	-8.94	AV
V	7206.00	54.24	30.33	6.32	24.55	54.78	74.00	-19.22	Pk
V	7206.00	45.7	30.33	6.32	24.55	46.24	54.00	-7.76	AV
V	9608.00	53.15	30.85	7.45	24.69	54.44	74.00	-19.56	Pk
V	9608.00	44.96	30.85	7.45	24.69	46.25	54.00	-7.75	AV
V	12010.00	56.66	31.02	8.99	25.57	60.2	74.00	-13.8	Pk
V	12010.00	45.41	31.02	8.99	25.57	48.95	54.00	-5.05	AV
H	4804.00	53.42	30.55	5.77	24.66	53.3	74.00	-20.7	Pk
H	4804.00	45.87	30.55	5.77	24.66	45.75	54.00	-8.25	AV
H	7206.00	55.1	30.33	6.32	24.55	55.64	74.00	-18.36	Pk
H	7206.00	45.57	30.33	6.32	24.55	46.11	54.00	-7.89	AV
H	9608.00	53.69	30.85	7.45	24.69	54.98	74.00	-19.02	Pk
H	9608.00	45.89	30.85	7.45	24.69	47.18	54.00	-6.82	AV
H	12010.00	55.41	31.02	8.99	25.57	58.95	74.00	-15.05	Pk
H	12010.00	45.01	31.02	8.99	25.57	48.55	54.00	-5.45	AV

Polar (H/V)	Frequency	Meter Reading	Pre-amplifier	Cable Loss	Antenna Factor	Emission Level	Limits	Margin	Detector Type
	(MHz)	(dBuV)	(dB)	(dB)	(dB)	(dBuV/m)	(dBuV/m)	(dB)	
Middle Channel:2441MHz									
V	4882.00	55.39	30.55	5.77	24.66	55.27	74.00	-18.73	Pk
V	4882.00	45.89	30.55	5.77	24.66	45.77	54.00	-8.23	AV
V	7323.00	55.29	30.33	6.32	24.55	55.83	74.00	-18.17	Pk
V	7323.00	45.46	30.33	6.32	24.55	46	54.00	-8	AV
V	9764.00	54.1	30.85	7.45	24.69	55.39	74.00	-18.61	Pk
V	9764.00	45.38	30.85	7.45	24.69	46.67	54.00	-7.33	AV
V	12205.00	53.61	31.02	8.99	25.57	57.15	74.00	-16.85	Pk
V	12205.00	45.52	31.02	8.99	25.57	49.06	54.00	-4.94	AV
H	4882.00	55.78	30.55	5.77	24.66	55.66	74.00	-18.34	Pk
H	4882.00	45.66	30.55	5.77	24.66	45.54	54.00	-8.46	AV
H	7323.00	56.16	30.33	6.32	24.55	56.7	74.00	-17.3	Pk
H	7323.00	45.05	30.33	6.32	24.55	45.59	54.00	-8.41	AV
H	9764.00	52.86	30.85	7.45	24.69	54.15	74.00	-19.85	Pk
H	9764.00	45.87	30.85	7.45	24.69	47.16	54.00	-6.84	AV
H	12205.00	52.25	31.02	8.99	25.57	55.79	74.00	-18.21	Pk
H	12205.00	45.9	31.02	8.99	25.57	49.44	54.00	-4.56	AV



Polar (H/V)	Frequency	Meter Reading	Pre-amplifier	Cable Loss	Antenna Factor	Emission Level	Limits	Margin	Detector Type
	(MHz)	(dBuV)	(dB)	(dB)	(dB)	(dBuV/m)	(dBuV/m)	(dB)	
High Channel:2480MHz									
V	4960.00	55.63	30.55	5.77	24.66	55.51	74.00	-18.49	Pk
V	4960.00	45.91	30.55	5.77	24.66	45.79	54.00	-8.21	AV
V	7440.00	54.8	30.33	6.32	24.55	55.34	74.00	-18.66	Pk
V	7440.00	44.95	30.33	6.32	24.55	45.49	54.00	-8.51	AV
V	9920.00	52.68	30.85	7.45	24.69	53.97	74.00	-20.03	Pk
V	9920.00	45.57	30.85	7.45	24.69	46.86	54.00	-7.14	AV
V	12400.00	53.43	31.02	8.99	25.57	56.97	74.00	-17.03	Pk
V	12400.00	45.41	31.02	8.99	25.57	48.95	54.00	-5.05	AV
H	4960.00	53.76	30.55	5.77	24.66	53.64	74.00	-20.36	Pk
H	4960.00	45.17	30.55	5.77	24.66	45.05	54.00	-8.95	AV
H	7440.00	53.49	30.33	6.32	24.55	54.03	74.00	-19.97	Pk
H	7440.00	45.4	30.33	6.32	24.55	45.94	54.00	-8.06	AV
H	9920.00	54.03	30.85	7.45	24.69	55.32	74.00	-18.68	Pk
H	9920.00	45.62	30.85	7.45	24.69	46.91	54.00	-7.09	AV
H	12400.00	56.57	31.02	8.99	25.57	60.11	74.00	-13.89	Pk
H	12400.00	45.24	31.02	8.99	25.57	48.78	54.00	-5.22	AV

Remark:

1. Emission Level = Meter Reading + Antenna Factor + Cable Loss – Pre-amplifier,
Margin= Emission Level - Limit
2. If peak below the average limit, the average emission was no test.
3. The amplitude of spurious emissions which are attenuated by more than 20dB below the permissible value has no need to be reported.



$\pi/4$ -DQPSK

Polar (H/V)	Frequency	Meter Reading	Pre-amplifier	Cable Loss	Antenna Factor	Emission Level	Limits	Margin	Detector Type
	(MHz)	(dBuV)	(dB)	(dB)	(dB)	(dBuV/m)	(dBuV/m)	(dB)	
Low Channel:2402MHz									
V	4804.00	53.93	30.55	5.77	24.66	53.81	74.00	-20.19	Pk
V	4804.00	45.5	30.55	5.77	24.66	45.38	54.00	-8.62	AV
V	7206.00	54.08	30.33	6.32	24.55	54.62	74.00	-19.38	Pk
V	7206.00	45.95	30.33	6.32	24.55	46.49	54.00	-7.51	AV
V	9608.00	55.61	30.85	7.45	24.69	56.9	74.00	-17.1	Pk
V	9608.00	45.31	30.85	7.45	24.69	46.6	54.00	-7.4	AV
V	12010.00	55	31.02	8.99	25.57	58.54	74.00	-15.46	Pk
V	12010.00	45.57	31.02	8.99	25.57	49.11	54.00	-4.89	AV
H	4804.00	56.67	30.55	5.77	24.66	56.55	74.00	-17.45	Pk
H	4804.00	45.96	30.55	5.77	24.66	45.84	54.00	-8.16	AV
H	7206.00	56.69	30.33	6.32	24.55	57.23	74.00	-16.77	Pk
H	7206.00	45.49	30.33	6.32	24.55	46.03	54.00	-7.97	AV
H	9608.00	55.22	30.85	7.45	24.69	56.51	74.00	-17.49	Pk
H	9608.00	45.75	30.85	7.45	24.69	47.04	54.00	-6.96	AV
H	12010.00	55.46	31.02	8.99	25.57	59	74.00	-15	Pk
H	12010.00	46.12	31.02	8.99	25.57	49.66	54.00	-4.34	AV

Polar (H/V)	Frequency	Meter Reading	Pre-amplifier	Cable Loss	Antenna Factor	Emission Level	Limits	Margin	Detector Type
	(MHz)	(dBuV)	(dB)	(dB)	(dB)	(dBuV/m)	(dBuV/m)	(dB)	
Middle Channel:2441MHz									
V	4882.00	53.19	30.55	5.77	24.66	53.07	74.00	-20.93	Pk
V	4882.00	45.88	30.55	5.77	24.66	45.76	54.00	-8.24	AV
V	7323.00	55.14	30.33	6.32	24.55	55.68	74.00	-18.32	Pk
V	7323.00	45.58	30.33	6.32	24.55	46.12	54.00	-7.88	AV
V	9764.00	56.76	30.85	7.45	24.69	58.05	74.00	-15.95	Pk
V	9764.00	45.9	30.85	7.45	24.69	47.19	54.00	-6.81	AV
V	12205.00	56.21	31.02	8.99	25.57	59.75	74.00	-14.25	Pk
V	12205.00	46.08	31.02	8.99	25.57	49.62	54.00	-4.38	AV
H	4882.00	52.37	30.55	5.77	24.66	52.25	74.00	-21.75	Pk
H	4882.00	45.14	30.55	5.77	24.66	45.02	54.00	-8.98	AV
H	7323.00	53.54	30.33	6.32	24.55	54.08	74.00	-19.92	Pk
H	7323.00	45.67	30.33	6.32	24.55	46.21	54.00	-7.79	AV
H	9764.00	53.93	30.85	7.45	24.69	55.22	74.00	-18.78	Pk
H	9764.00	45.74	30.85	7.45	24.69	47.03	54.00	-6.97	AV
H	12205.00	55.92	31.02	8.99	25.57	59.46	74.00	-14.54	Pk
H	12205.00	45.52	31.02	8.99	25.57	49.06	54.00	-4.94	AV



Polar (H/V)	Frequency	Meter Reading	Pre-amplifier	Cable Loss	Antenna Factor	Emission Level	Limits	Margin	Detector Type
	(MHz)	(dBuV)	(dB)	(dB)	(dB)	(dBuV/m)	(dBuV/m)	(dB)	
High Channel:2480MHz									
V	4960.00	52.77	30.55	5.77	24.66	52.65	74.00	-21.35	Pk
V	4960.00	45.3	30.55	5.77	24.66	45.18	54.00	-8.82	AV
V	7440.00	52.87	30.33	6.32	24.55	53.41	74.00	-20.59	Pk
V	7440.00	45.41	30.33	6.32	24.55	45.95	54.00	-8.05	AV
V	9920.00	55.78	30.85	7.45	24.69	57.07	74.00	-16.93	Pk
V	9920.00	45.63	30.85	7.45	24.69	46.92	54.00	-7.08	AV
V	12400.00	53.77	31.02	8.99	25.57	57.31	74.00	-16.69	Pk
V	12400.00	45.55	31.02	8.99	25.57	49.09	54.00	-4.91	AV
H	4960.00	53.83	30.55	5.77	24.66	53.71	74.00	-20.29	Pk
H	4960.00	45.66	30.55	5.77	24.66	45.54	54.00	-8.46	AV
H	7440.00	56.79	30.33	6.32	24.55	57.33	74.00	-16.67	Pk
H	7440.00	45.34	30.33	6.32	24.55	45.88	54.00	-8.12	AV
H	9920.00	54.01	30.85	7.45	24.69	55.3	74.00	-18.7	Pk
H	9920.00	46.1	30.85	7.45	24.69	47.39	54.00	-6.61	AV
H	12400.00	54.07	31.02	8.99	25.57	57.61	74.00	-16.39	Pk
H	12400.00	45.36	31.02	8.99	25.57	48.9	54.00	-5.1	AV

Remark:

1. Emission Level = Meter Reading + Antenna Factor + Cable Loss – Pre-amplifier,
Margin= Emission Level - Limit
2. If peak below the average limit, the average emission was no test.
3. The amplitude of spurious emissions which are attenuated by more than 20dB below the permissible value has no need to be reported.



8DPSK

Polar (H/V)	Frequency	Meter Reading	Pre-amplifier	Cable Loss	Antenna Factor	Emission Level	Limits	Margin	Detector Type
	(MHz)	(dBuV)	(dB)	(dB)	(dB)	(dBuV/m)	(dBuV/m)	(dB)	
Low Channel:2402MHz									
V	4804.00	53.93	30.55	5.77	24.66	53.81	74.00	-20.19	Pk
V	4804.00	45.5	30.55	5.77	24.66	45.38	54.00	-8.62	AV
V	7206.00	54.08	30.33	6.32	24.55	54.62	74.00	-19.38	Pk
V	7206.00	45.95	30.33	6.32	24.55	46.49	54.00	-7.51	AV
V	9608.00	55.61	30.85	7.45	24.69	56.9	74.00	-17.1	Pk
V	9608.00	45.31	30.85	7.45	24.69	46.6	54.00	-7.4	AV
V	12010.00	55	31.02	8.99	25.57	58.54	74.00	-15.46	Pk
V	12010.00	45.57	31.02	8.99	25.57	49.11	54.00	-4.89	AV
H	4804.00	56.67	30.55	5.77	24.66	56.55	74.00	-17.45	Pk
H	4804.00	45.96	30.55	5.77	24.66	45.84	54.00	-8.16	AV
H	7206.00	56.69	30.33	6.32	24.55	57.23	74.00	-16.77	Pk
H	7206.00	45.49	30.33	6.32	24.55	46.03	54.00	-7.97	AV
H	9608.00	55.22	30.85	7.45	24.69	56.51	74.00	-17.49	Pk
H	9608.00	45.75	30.85	7.45	24.69	47.04	54.00	-6.96	AV
H	12010.00	55.46	31.02	8.99	25.57	59	74.00	-15	Pk
H	12010.00	46.12	31.02	8.99	25.57	49.66	54.00	-4.34	AV

Polar (H/V)	Frequency	Meter Reading	Pre-amplifier	Cable Loss	Antenna Factor	Emission Level	Limits	Margin	Detector Type
	(MHz)	(dBuV)	(dB)	(dB)	(dB)	(dBuV/m)	(dBuV/m)	(dB)	
Middle Channel:2441MHz									
V	4882.00	53.19	30.55	5.77	24.66	53.07	74.00	-20.93	Pk
V	4882.00	45.88	30.55	5.77	24.66	45.76	54.00	-8.24	AV
V	7323.00	55.14	30.33	6.32	24.55	55.68	74.00	-18.32	Pk
V	7323.00	45.58	30.33	6.32	24.55	46.12	54.00	-7.88	AV
V	9764.00	56.76	30.85	7.45	24.69	58.05	74.00	-15.95	Pk
V	9764.00	45.9	30.85	7.45	24.69	47.19	54.00	-6.81	AV
V	12205.00	56.21	31.02	8.99	25.57	59.75	74.00	-14.25	Pk
V	12205.00	46.08	31.02	8.99	25.57	49.62	54.00	-4.38	AV
H	4882.00	52.37	30.55	5.77	24.66	52.25	74.00	-21.75	Pk
H	4882.00	45.14	30.55	5.77	24.66	45.02	54.00	-8.98	AV
H	7323.00	53.54	30.33	6.32	24.55	54.08	74.00	-19.92	Pk
H	7323.00	45.67	30.33	6.32	24.55	46.21	54.00	-7.79	AV
H	9764.00	53.93	30.85	7.45	24.69	55.22	74.00	-18.78	Pk
H	9764.00	45.74	30.85	7.45	24.69	47.03	54.00	-6.97	AV
H	12205.00	55.92	31.02	8.99	25.57	59.46	74.00	-14.54	Pk
H	12205.00	45.52	31.02	8.99	25.57	49.06	54.00	-4.94	AV



Polar (H/V)	Frequency	Meter Reading	Pre-amplifier	Cable Loss	Antenna Factor	Emission Level	Limits	Margin	Detector Type
	(MHz)	(dBuV)	(dB)	(dB)	(dB)	(dBuV/m)	(dBuV/m)	(dB)	
High Channel:2480MHz									
V	4960.00	52.77	30.55	5.77	24.66	52.65	74.00	-21.35	Pk
V	4960.00	45.3	30.55	5.77	24.66	45.18	54.00	-8.82	AV
V	7440.00	52.87	30.33	6.32	24.55	53.41	74.00	-20.59	Pk
V	7440.00	45.41	30.33	6.32	24.55	45.95	54.00	-8.05	AV
V	9920.00	55.78	30.85	7.45	24.69	57.07	74.00	-16.93	Pk
V	9920.00	45.63	30.85	7.45	24.69	46.92	54.00	-7.08	AV
V	12400.00	53.77	31.02	8.99	25.57	57.31	74.00	-16.69	Pk
V	12400.00	45.55	31.02	8.99	25.57	49.09	54.00	-4.91	AV
H	4960.00	53.83	30.55	5.77	24.66	53.71	74.00	-20.29	Pk
H	4960.00	45.66	30.55	5.77	24.66	45.54	54.00	-8.46	AV
H	7440.00	56.79	30.33	6.32	24.55	57.33	74.00	-16.67	Pk
H	7440.00	45.34	30.33	6.32	24.55	45.88	54.00	-8.12	AV
H	9920.00	54.01	30.85	7.45	24.69	55.3	74.00	-18.7	Pk
H	9920.00	46.1	30.85	7.45	24.69	47.39	54.00	-6.61	AV
H	12400.00	54.07	31.02	8.99	25.57	57.61	74.00	-16.39	Pk
H	12400.00	45.36	31.02	8.99	25.57	48.9	54.00	-5.1	AV

Remark:

1. Emission Level = Meter Reading + Antenna Factor + Cable Loss – Pre-amplifier,
Margin= Emission Level - Limit
2. If peak below the average limit, the average emission was no test.
3. The amplitude of spurious emissions which are attenuated by more than 20dB below the permissible value has no need to be reported.



5. RADIATED BAND EMISSION MEASUREMENT

5.1 Test Requirement:

Test Requirement:	FCC Part15 C Section 15.209 and 15.205				
Test Method:	ANSI C63.10: 2013				
Test Frequency Range:	All of the restrict bands were tested, only the worst band's (2310MHz to 2500MHz) data was showed.				
Test site:	Measurement Distance: 3m				
Receiver setup:	Frequency	Detector	RBW	VBW	Value
	Above 1GHz	Peak	1MHz	3MHz	Peak
		Average	1MHz	3MHz	Average

LIMITS OF RADIATED EMISSION MEASUREMENT (Above 1000MHz)

FREQUENCY (MHz)	Limit (dBuV/m) (at 3M)	
	PEAK	AVERAGE
Above 1000	74	54

Notes:

- (1) The limit for radiated test was performed according to FCC PART 15C.
- (2) The tighter limit applies at the band edges.
- (3) Emission level (dBuV/m)=20log Emission level (uV/m).

Spectrum Parameter	Setting
Attenuation	Auto
Start Frequency	2300MHz
Stop Frequency	2520
RB / VB (emission in restricted band)	1 MHz / 1 MHz for Peak, 1 MHz / 10Hz for Average

5.2 TEST PROCEDURE

Above 1GHz test procedure as below:

- a. 1. The EUT was placed on the top of a rotating table 1.5 meters above the ground at a 3 meter camber. The table was rotated 360 degrees to determine the position of the highest radiation.
- b. The EUT was set 3 meters away from the interference-receiving antenna, which was mounted on the top of a variable-height antenna tower.
- c. The antenna height is varied from one meter to four meters above the ground to determine the maximum value of the field strength. Both horizontal and vertical polarizations of the antenna are set to make the measurement.
- d. For each suspected emission, the EUT was arranged to its worst case and then the antenna was tuned to heights from 1 meter to 4 meters and the rota table was turned from 0 degrees to 360 degrees to find the maximum reading.
- e. The test-receiver system was set to Peak Detect Function and Specified Bandwidth with Maximum Hold Mode.
- f. If the emission level of the EUT in peak mode was 10dB lower than the limit specified, then testing could be stopped and the peak values of the EUT would be reported. Otherwise the emissions that did not have 10dB margin would be re-tested one by one using peak, quasi-peak or average method as specified and then reported in a data sheet.
- g. Test the EUT in the lowest channel,the Highest channel

Note:



Both horizontal and vertical antenna polarities were tested and performed pretest to three orthogonal axis. The worst case emissions were reported

5.3 DEVIATION FROM TEST STANDARD

No deviation

5.4 TEST SETUP

Radiated Emission Test-Up Frequency Above 1GHz

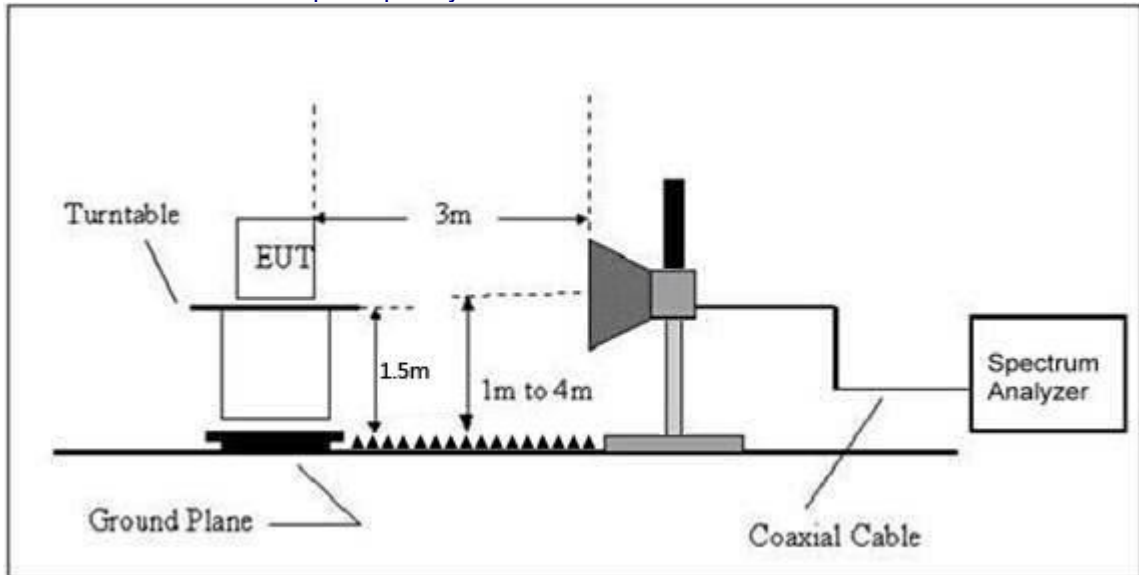

5.5 EUT OPERATING CONDITIONS

The EUT tested system was configured as the statements of 2.3 Unless otherwise a special operating condition is specified in the follows during the testing.



5.6 TEST RESULT

	Polar (H/V)	Frequency (MHz)	Meter Reading (dBUV)	Pre-amplifier (dB)	Cable Loss (dB)	Antenna Factor (dB/m)	Emission level (dBUV/m)	Limit (dBUV/m)	Detector Type	Result
GFSK	Low Channel: 2402MHz									
	H	2390.00	55.68	30.22	4.85	23.98	54.29	74.00	PK	PASS
	H	2390.00	46.08	30.22	4.85	23.98	44.69	54.00	AV	PASS
	H	2400.00	55.46	30.22	4.85	23.98	54.07	74.00	PK	PASS
	H	2400.00	46.37	30.22	4.85	23.98	44.98	54.00	AV	PASS
	V	2390.00	54.51	30.22	4.85	23.98	53.12	74.00	PK	PASS
	V	2390.00	46.15	30.22	4.85	23.98	44.76	54.00	AV	PASS
	V	2400.00	55.94	30.22	4.85	23.98	54.55	74.00	PK	PASS
	V	2400.00	46.28	30.22	4.85	23.98	44.89	54.00	AV	PASS
	High Channel: 2480MHz									
	H	2483.50	55.8	30.22	4.85	23.98	54.41	74.00	PK	PASS
	H	2483.50	45.8	30.22	4.85	23.98	44.41	54.00	AV	PASS
	H	2500.00	56.07	30.22	4.85	23.98	54.68	74.00	PK	PASS
	H	2500.00	45.64	30.22	4.85	23.98	44.25	54.00	AV	PASS
	V	2483.50	55.39	30.22	4.85	23.98	54	74.00	PK	PASS
	V	2483.50	45.94	30.22	4.85	23.98	44.55	54.00	AV	PASS
	V	2500.00	55.03	30.22	4.85	23.98	53.64	74.00	PK	PASS
	V	2500.00	46.23	30.22	4.85	23.98	44.84	54.00	AV	PASS
π/4-DQPSK	Low Channel: 2402MHz									
	H	2390.00	55.89	30.22	4.85	23.98	54.5	74.00	PK	PASS
	H	2390.00	45.84	30.22	4.85	23.98	44.45	54.00	AV	PASS
	H	2400.00	55.18	30.22	4.85	23.98	53.79	74.00	PK	PASS
	H	2400.00	45.48	30.22	4.85	23.98	44.09	54.00	AV	PASS
	V	2390.00	55.38	30.22	4.85	23.98	53.99	74.00	PK	PASS
	V	2390.00	45.59	30.22	4.85	23.98	44.2	54.00	AV	PASS
	V	2400.00	55.84	30.22	4.85	23.98	54.45	74.00	PK	PASS
	V	2400.00	46.33	30.22	4.85	23.98	44.94	54.00	AV	PASS
	High Channel: 2480MHz									
	H	2483.50	54.53	30.22	4.85	23.98	53.14	74.00	PK	PASS
	H	2483.50	45.86	30.22	4.85	23.98	44.47	54.00	AV	PASS
	H	2500.00	55.34	30.22	4.85	23.98	53.95	74.00	PK	PASS
	H	2500.00	46.25	30.22	4.85	23.98	44.86	54.00	AV	PASS
	V	2483.50	55.86	30.22	4.85	23.98	54.47	74.00	PK	PASS
	V	2483.50	45.63	30.22	4.85	23.98	44.24	54.00	AV	PASS
	V	2500.00	56.08	30.22	4.85	23.98	54.69	74.00	PK	PASS
	V	2500.00	45.69	30.22	4.85	23.98	44.3	54.00	AV	PASS



Low Channel: 2402MHz											
8DPSK	H	2390.00	54.64	30.22	4.85	23.98	53.25	74.00	PK	PASS	
	H	2390.00	44.59	30.22	4.85	23.98	43.2	54.00	AV	PASS	
	H	2400.00	53.93	30.22	4.85	23.98	52.54	74.00	PK	PASS	
	H	2400.00	44.23	30.22	4.85	23.98	42.84	54.00	AV	PASS	
	V	2390.00	54.13	30.22	4.85	23.98	52.74	74.00	PK	PASS	
	V	2390.00	44.34	30.22	4.85	23.98	42.95	54.00	AV	PASS	
	V	2400.00	54.59	30.22	4.85	23.98	53.2	74.00	PK	PASS	
	V	2400.00	45.08	30.22	4.85	23.98	43.69	54.00	AV	PASS	
	High Channel: 2480MHz										
	H	2483.50	53.49	30.22	4.85	23.98	52.1	74.00	PK	PASS	
	H	2483.50	44.82	30.22	4.85	23.98	43.43	54.00	AV	PASS	
	H	2500.00	54.3	30.22	4.85	23.98	52.91	74.00	PK	PASS	
	H	2500.00	45.21	30.22	4.85	23.98	43.82	54.00	AV	PASS	
	V	2483.50	54.82	30.22	4.85	23.98	53.43	74.00	PK	PASS	
	V	2483.50	44.59	30.22	4.85	23.98	43.2	54.00	AV	PASS	
	V	2500.00	55.04	30.22	4.85	23.98	53.65	74.00	PK	PASS	
V	2500.00	44.65	30.22	4.85	23.98	43.26	54.00	AV	PASS		



6. CONDUCTED BAND EDGE AND SPURIOUS EMISSION

Test Requirement:	FCC Part15 C Section 15.247 (d)
Test Method:	KDB558074 D0115.247 Meas Guidancev05r02

6.1 Limit

Regulation 15.247 (d), In any 100 kHz bandwidth outside the frequency band in which the spread spectrum or digitally modulated intentional radiator is operating, the radio frequency power that is produced by the intentional radiator shall be at least 20 dB below that in the 100 kHz bandwidth within the band that contains the highest level of the desired power, based on either an RF conducted or a radiated measurement, provided the transmitter demonstrates compliance with the peak conducted power limits. If the transmitter complies with the conducted power limits based on the use of RMS averaging over a time interval, as permitted under paragraph (b)(3) of this section, the attenuation required under this paragraph shall be 30 dB instead of 20 dB. Attenuation below the general limits specified in §15.209(a) is not required. In addition, radiated emissions which fall in the restricted bands, as defined in §15.205(a), must also comply with the radiated emission limits specified in §15.209(a) (see §15.205(c)).

6.2 Test Setup



6.3 Test procedure

Using the following spectrum analyzer setting:

- A) Set the RBW = 100KHz.
- B) Set the VBW = 300KHz.
- C) Sweep time = auto couple.
- D) Detector function = peak.
- E) Trace mode = max hold.
- F) Allow trace to fully stabilize.

6.4 DEVIATION FROM STANDARD

No deviation.

6.5 Test Result

Measurement Data : The detailed test data see Appendix I



7. 20DB BANDWIDTH & 99% OCCUPIED BANDWIDTH

Test Requirement:	FCC Part15 C Section 15.247 (a)(2)
Test Method:	ANSI C63.10:2013 and KDB558074 D01 DTS Meas Guidance v05r02

7.1 Test Setup



7.2 Limit

N/A

7.3 Test procedure

1. Set RBW = 1% to 5% of the OBW.
2. Set the video bandwidth (VBW) $\geq 3 \times$ RBW.
3. Detector = Peak.
4. Trace mode = max hold.
5. Sweep = auto couple.
6. Allow the trace to stabilize.
7. Measure the maximum width of the emission that is constrained by the frequencies associated with the two outermost amplitude points (upper and lower frequencies) that are attenuated by 6 dB relative to the maximum level measured in the fundamental emission.

7.4 DEVIATION FROM STANDARD

No deviation.

7.5 Test Result

Measurement Data : The detailed test data see Appendix I



8. Maximum Peak Output Power

Test Requirement:	FCC Part15 C Section 15.247 (b)(3)
Test Method:	ANSI C63.10:2013
Limit:	GFSK:30 dBm $\pi/4$ -DQPSK & 8-DPSK:20.97 dBm
EIRP Limit:	36dBm

8.1 Block Diagram Of Test Setup



8.2 Limit

For frequency hopping systems operating in the 2400-2483.5 MHz band employing at least 75 non-overlapping hopping channels, and all frequency hopping systems in the 5725-5850 MHz band: 1 watt.
For all other frequency hopping systems in the 2400-2483.5 MHz band: 0.125 watts.

For FHSs operating in the band 2400-2483.5 MHz, the maximum peak conducted output power shall not exceed 1.0 W if the hopset uses 75 or more hopping channels; the maximum peak conducted output power shall not exceed 0.125 W if the hopset uses less than 75 hopping channels. The e.i.r.p. shall not exceed 4 W.

8.3 Test procedure

1. Remove the antenna from the EUT and then connect a low RF cable from the antenna port to the spectrum.
2. Set the spectrum analyzer: RBW = 2MHz. VBW =2MHz. Sweep = auto; Detector Function = Peak.
3. Keep the EUT in transmitting at lowest, medium and highest channel individually. Record the max value.

8.4 DEVIATION FROM STANDARD

No deviation.

8.5 Test Result

Measurement Data : The detailed test data see Appendix I



9. HOPPING CHANNEL SEPARATION

Test Requirement:	FCC Part15 C Section 15.247 (a)(1)
Test Method:	ANSI C63.10:2013
Receiver setup:	RBW=300KHz, VBW=300KHz, detector=Peak
Limit:	GFSK: 20dB bandwidth $\pi/4$ -DQPSK : 0.025MHz or 2/3 of the 20dB bandwidth (whichever is greater)

9.1 Test Setup



9.2 Test procedure

1. Remove the antenna from the EUT and then connect a low RF cable from the antenna port to the spectrum.
2. Set the spectrum analyzer: RBW = 300kHz. VBW = 300kHz , Span = 3.0MHz. Sweep = auto; Detector Function = Peak. Trace = Max hold.
3. Allow the trace to stabilize. Use the marker-delta function to determine the separation between the peaks of the adjacent channels. The limit is specified in one of the subparagraphs of this Section Submit this plot.

9.3 DEVIATION FROM STANDARD

No deviation.

9.4 Test Result

Measurement Data : The detailed test data see Appendix I



10.NUMBER OF HOPPING FREQUENCY

Test Requirement:	FCC Part15 C Section 15.247 (a)(1)(iii)
Test Method:	ANSI C63.10:2013
Receiver setup:	RBW=300kHz, VBW=300kHz, Frequency range=2400MHz-2483.5MHz, Detector=Peak
Limit:	15 channels

10.1 Test Setup

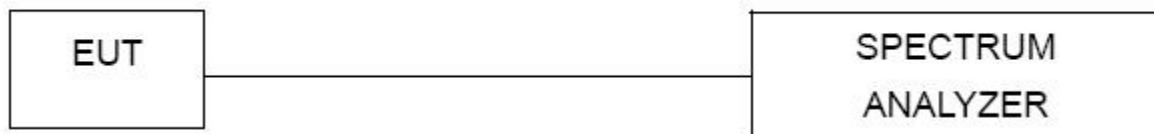

10.2 Test procedure

1. Remove the antenna from the EUT and then connect a low RF cable from the antenna port to the spectrum.
2. Set the spectrum analyzer: RBW = 100kHz. VBW = 300kHz. Sweep = auto; Detector Function = Peak. Trace = Max hold.
3. Allow the trace to stabilize. It may prove necessary to break the span up to sections. in order to clearly show all of the hopping frequencies. The limit is specified in one of the subparagraphs of this Section.
4. Set the spectrum analyzer: Start Frequency = 2.4GHz, Stop Frequency = 2.4835GHz. Sweep=auto;

10.3 DEVIATION FROM STANDARD

No deviation.

10.4 Test Result

Measurement Data : The detailed test data see Appendix I



11. DWELL TIME

Test Requirement:	FCC Part15 C Section 15.247 (a)(1)(iii)
Test Method:	ANSI C63.10:2013
Receiver setup:	RBW=910KHz, VBW=910KHz, Span=0Hz, Detector=Peak
Limit:	0.4 Second

11.1 Test Setup

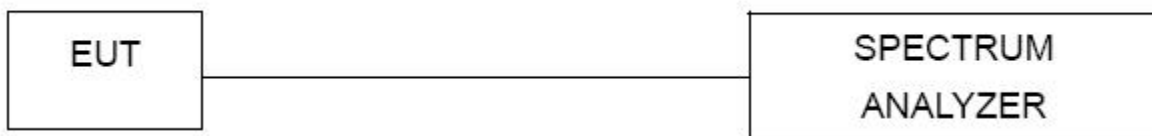

11.2 Test procedure

1. Remove the antenna from the EUT and then connect a low RF cable from the antenna port to the spectrum.
2. Set spectrum analyzer span = 0Hz;
3. Set RBW = 910KHz and VBW = 910KHz.Sweep = as necessary to capture the entire dwell time per hopping channel. Set the EUT for DH5, DH3 and DH1 packet transmitting.
4. Use the marker-delta function to determine the dwell time. If this value varies with different modes of operation (e.g.. data rate. modulation format. etc.). repeat this test for each variation. The limit is specified in one of the subparagraphs of this Section. Submit this plot(s).

11.3 DEVIATION FROM STANDARD

No deviation.

11.4 Test Result

Measurement Data : The detailed test data see Appendix I



12. Antenna Requirement

Standard requirement:	FCC Part15 C Section 15.203 /247(c)
15.203 requirement: An intentional radiator shall be designed to ensure that no antenna other than that furnished by the responsible party shall be used with the device. The use of a permanently attached antenna or of an antenna that uses a unique coupling to the intentional radiator, the manufacturer may design the unit so that a broken antenna can be replaced by the user, but the use of a standard antenna jack or electrical connector is prohibited.	
15.247(c) (1)(i) requirement: (i) Systems operating in the 2400-2483.5 MHz band that is used exclusively for fixed. Point-to-point operations may employ transmitting antennas with directional gain greater than 6dBi provided the maximum conducted output power of the intentional radiator is reduced by 1 dB for every 3 dB that the directional gain of the antenna exceeds 6dBi.	
EUT Antenna:	
The antenna is FPC antenna, the best case gain of the antennas is 0.25 dBi, reference to the Appendix -EUT PHOTO Internal Photos for details	



13. Test Setup Photo

Reference to the appendix **Test Setup Photo** for details.

14. EUT Constructional Details

Reference to the appendix External Photos & Internal Photos for details.

***** END OF REPORT *****