



FCC TEST REPORT

FCC ID:2BK25-HB-F1

Report Number : ZKT-24092011941E

Date of Test Sep. 04, 2024 to Sep. 20, 2024

Date of issue : Sep. 20, 2024

Total number of pages 59

Test Result : PASS

Testing Laboratory : **Shenzhen ZKT Technology Co., Ltd.**

Address : 1/F, No. 101, Building B, No. 6, Tangwei Community Industrial Avenue, Fuhai Street, Bao'an District, Shenzhen, China

Applicant's name : **Shenzhen Xinvo Digital Company Limited**

Address : 5th Floor, Building 10, Longbi Industrial Park, Dafa Road, Bantian, Longgang, Shenzhen City, China.

Manufacturer's name : **Shenzhen Xinvo Digital Company Limited**

Address : 5th Floor, Building 10, Longbi Industrial Park, Dafa Road, Bantian, Longgang, Shenzhen City, China.

Test specification:

Standard : FCC CFR Title 47 Part 15 Subpart C Section 15.247
ANSI C63.10:2013

Test procedure : /

Non-standard test method : N/A

Test Report Form No. : TRF-EL-110_V0

Test Report Form(s) Originator : ZKT Testing

Master TRF : Dated: 2020-01-06

This device described above has been tested by ZKT, and the test results show that the equipment under test (EUT) is in compliance with the FCC requirements. And it is applicable only to the tested sample identified in the report.

This report shall not be reproduced except in full, without the written approval of ZKT, this document may be altered or revised by ZKT, personal only, and shall be noted in the revision of the document.

Product name : **Smart bird feeder**

Trademark : N/A

Model/Type reference : HB-F1

Ratings : Input: DC 5V USB or DC 3.7V Battery



Testing procedure and testing location:

Testing Laboratory.....: **Shenzhen ZKT Technology Co., Ltd.**

Address.....: 1/F, No. 101, Building B, No. 6, Tangwei Community Industrial Avenue, Fuhai Street, Bao'an District, Shenzhen, China

Tested by (name + signature).....: Jim Liu

Reviewer (name + signature).....: Jackson Fang

Approved (name + signature).....: Lake Xie





Table of Contents

	Page
1. VERSION	5
2. SUMMARY OF TEST RESULTS	6
2.1 TEST FACILITY	7
2.2 MEASUREMENT UNCERTAINTY	7
3. GENERAL INFORMATION	8
3.1 GENERAL DESCRIPTION OF EUT	8
3.2 DESCRIPTION OF TEST MODES	9
3.3 BLOCK DIGRAM SHOWING THE CONFIGURATION OF SYSTEM TESTED	10
3.4 DESCRIPTION OF SUPPORT UNITS(CONDUCTED MODE)	10
3.5EQUIPMENTS LIST FOR ALL TEST ITEMS	11
4. EMC EMISSION TEST	13
4.1 CONDUCTED EMISSION MEASUREMENT	13
4.1.1 POWER LINE CONDUCTED EMISSION LIMITS	13
4.1.2 TEST PROCEDURE	13
4.1.3 DEVIATION FROM TEST STANDARD	13
4.1.4 TEST SETUP	14
4.1.5 EUT OPERATING CONDITIONS	14
4.1.6 TEST RESULT	15
4.2 RADIATED EMISSION MEASUREMENT	17
4.2.1 RADIATED EMISSION LIMITS	17
4.2.2 TEST PROCEDURE	17
4.2.3 DEVIATION FROM TEST STANDARD	18
4.2.4 TEST SETUP	18
4.2.5 EUT OPERATING CONDITIONS	19
4.2.6 TEST RESULTS	19
5. RADIATED BANDEMISSIONMEASUREMENT	28
5.1 TEST REQUIREMENT	28
5.2 TEST PROCEDURE	28
5.3 DEVIATION FROM TEST STANDARD	28
5.4 TEST SETUP	29
5.5 EUT OPERATING CONDITIONS	29
5.6 TEST RESULT	30
6. POWER SPECTRAL DENSITY TEST	32
6.1 APPLIED PROCEDURES / LIMIT	32
6.2 TEST PROCEDURE	32
6.3 DEVIATION FROM STANDARD	32
6.4 TEST SETUP	32



6.5 EUT OPERATION CONDITIONS	32
6.6 TEST RESULT	33
7. 6DB OCCUPIED BANDWIDTH	37
7.1 APPLIED PROCEDURES / LIMIT	37
7.2 TEST PROCEDURE	37
7.3 DEVIATION FROM STANDARD	37
7.4 TEST SETUP	37
7.5 EUT OPERATION CONDITIONS	37
7.6 TEST RESULT	38
8.PEAK OUTPUT POWER TEST	42
8.1 APPLIED PROCEDURES/LIMIT	42
8.2 TEST PROCEDURE	42
8.3 DEVIATION FROM STANDARD	42
8.4 TEST SETUP	42
8.5 EUT OPERATION CONDITIONS	42
8.6 TEST RESULT	43
9. CONDUCTED BAND EDGE AND SPURIOUS EMISSION	44
9.1 APPLICABLE STANDARD	44
9.2 TEST PROCEDURE	44
9.3 DEVIATION FROM STANDARD	44
9.4 TEST SETUP	44
9.5 EUT OPERATION CONDITIONS	44
9.6 TEST RESULTS	44
10. DUTY CYCLE	54
10.1 APPLIED PROCEDURES / LIMIT	54
10.2 DEVIATION FROM STANDARD	54
10.3 TEST SETUP	54
10.4 TEST RESULTS	55
11. ANTENNA REQUIREMENT	58
12. TEST SETUP PHOTO	59
13. EUT CONSTRUCTIONAL DETAILS	59



1. VERSION

Report No.	Version	Description	Approved
ZKT-24092011941E	Rev.01	Initial issue of report	Sep. 20, 2024



2. SUMMARY OF TEST RESULTS

Test procedures according to the technical standards:

FCC Part15 (15.247) , Subpart C				
Standard Section	Test Item	Result	Remark	
FCC part 15.203/15.247 (c)	Antenna requirement	PASS		
FCC part 15.207	AC Power Line Conducted Emission	PASS		
FCC part 15.247 (b)(3)	Conducted Peak Output Power	PASS		
FCC part 15.247 (a)(2)	6dB Occupied Bandwidth	PASS		
FCC part 15.247 (e)	Power Spectral Density	PASS		
FCC part 15.247(d)	Band Edge	PASS		
FCC part 15.205/15.209	Spurious Emission	PASS		
ANSI C63.10:2013	Duty cycle	PASS		

NOTE:

(1) "N/A" denotes test is not applicable in this Test Report



2.1 TEST FACILITY

Shenzhen ZKT Technology Co., Ltd.
Add. : 1/F, No. 101, Building B, No. 6, Tangwei Community Industrial Avenue, Fuhai Street, Bao'an District, Shenzhen, China

FCC Test Firm Registration Number: 692225
Designation Number: CN1299
IC Registered No.: 27033
CAB identifier: CN0110

2.2 MEASUREMENT UNCERTAINTY

The reported uncertainty of measurement $y \pm U$ where expanded uncertainty U is based on a standard uncertainty multiplied by a coverage factor of $k=2$ providing a level of confidence of approximately 95 %.

No.	Item	Uncertainty
1	3m chamber Radiated spurious emission(9KHz-30MHz)	U=4.5dB
2	3m chamber Radiated spurious emission(30MHz-1GHz)	U=4.8dB
3	3m chamber Radiated spurious emission(1GHz-6GHz)	U=4.9dB
4	3m chamber Radiated spurious emission(6GHz-40GHz)	U=5.0dB
5	Conducted disturbance	U=3.2dB
6	RF Band Edge	U=1.68dB
7	RF power conducted	U=1.86dB
8	RF conducted Spurious Emission	U=2.2dB
9	RF Occupied Bandwidth	U=1.8MHz
10	RF Power Spectral Density	U=1.75dB
11	humidity uncertainty	U=5.3%
12	Temperature uncertainty	U=0.59°C



3. GENERAL INFORMATION

3.1 GENERAL DESCRIPTION OF EUT

Product Name:	Smart bird feeder
Model No.:	HB-F1
Serial No.:	N/A
Model Different.:	N/A
Hardware Version:	H1.0
Software Version:	S1.0
Sample(s) Status:	Engineer sample
Channel numbers:	802.11b/g/n20: 11 CH
Channel separation:	5MHz
Modulation technology:	802.11b: Direct Sequence Spread Spectrum(DSSS) 802.11g/n20: Orthogonal Frequency Division Multiplexing(OFDM)
Data Rate	802.11b: 1/2/5.5/11Mbit/s 802.11g: 6/9/12/24/18/36/48/54Mbit/s 802.11n20:MCS0-MCS7
Antenna Type:	FPC Antenna
Antenna gain:	2.0dBi
Power supply:	Input: DC 5V USB or DC 3.7V Battery



Operation Frequency each of channel							
Channel	Frequency	Channel	Frequency	Channel	Frequency	Channel	Frequency
1	2412MHz	4	2427MHz	7	2442MHz	10	2457MHz
2	2417MHz	5	2432MHz	8	2447MHz	11	2462MHz
3	2422MHz	6	2437MHz	9	2452MHz	X	

Note:

In section 15.31(m), regards to the operating frequency range over 10 MHz, the Lowest frequency, the middle frequency, and the highest frequency of channel were selected to perform the test, and the selected channel see below:

Test channel	Frequency (MHz)
	802.11b/g/n20
Lowest channel	2412MHz
Middle channel	2437MHz
Highest channel	2462MHz

3.2 DESCRIPTION OF TEST MODES

Transmitting mode	Keep the EUT in continuously transmitting mode
<p>Remark: During the test, the test voltage was tuned from 85% to 115% of the nominal rated supply voltage, and found that the worst case was under the nominal rated supply condition. So the report just shows that condition's data.</p> <p>For battery operated equipment, the equipment tests shall be performed using a new battery.</p>	

<p>We have verified the construction and function in typical operation. All the test modes were carried out with the EUT in transmitting operation, which was shown in this test report and defined as follows:</p>				
<p>Pre-scan all kind of data rate in lowest channel, and found the follow list which it was worst case.</p>				
Mode	802.11b	802.11g	802.11n20	
Data rate	1Mbps	6Mbps	MCS00(HT0)	

Test Software	WIFI testing software
Power level setup	Default



3.3 BLOCK DIGRAM SHOWING THE CONFIGURATION OF SYSTEM TESTED

Conducted Emission



Radiated Emission



Conducted Spurious



3.4 DESCRIPTION OF SUPPORT UNITS(CONDUCTED MODE)

The EUT has been tested as an independent unit together with other necessary accessories or support units. The following support units or accessories were used to form a representative test configuration during the tests.

Item	Equipment	Mfr/Brand	Model/Type No.	Series No.	Note
E-1	Smart bird feeder	N/A	HB-F1	N/A	EUT
A1	AC/DC Adapter	HUAWEI	HW-050450C00	N/A	Auxiliary

Item	Shielded Type	Ferrite Core	Length	Note

Note:

- (1) The support equipment was authorized by Declaration of Confirmation.
- (2) For detachable type I/O cable should be specified the length in cm in 『Length』 column.
- (3) EUT is tested with new battery.



3.5EQUIPMENTS LIST FOR ALL TEST ITEMS

Conduction Test equipment

Item	Kind of Equipment	Manufacturer	Type No.	Serial No.	Firmware Version	Last calibration	Calibrated until
1	LISN	R&S	ENV216	101471	N/A	Nov. 14, 2023	Nov. 13, 2024
2	LISN	CYBERTEK	EM5040A	E1850400149	N/A	Nov. 02, 2023	Nov. 01, 2024
3	Test Cable	N/A	C-01	N/A	N/A	Nov. 02, 2023	Nov. 01, 2024
4	Test Cable	N/A	C-02	N/A	N/A	Nov. 02, 2023	Nov. 01, 2024
5	Test Cable	N/A	C-03	N/A	N/A	Nov. 02, 2023	Nov. 01, 2024
6	EMI Test Receiver	R&S	ESCI3	101393	4.42 SP3	Nov. 02, 2023	Nov. 01, 2024
7	Triple-Loop Antenna	N/A	RF300	N/A	N/A	Nov. 02, 2023	Nov. 01, 2024
8	Absorbing Clamp	DZ	ZN23201	15034	N/A	Nov. 07, 2023	Nov. 06, 2024
9	EMC Software	Frad	EZ-EMC	Ver.EMC-CON 3A1.1	N/A	\	\

Radiation Test equipment

Item	Equipment	Manufacturer	Type No.	Serial No.	Firmware Version	Last calibration	Calibrated until
1	Spectrum Analyzer (9kHz-26.5GHz)	KEYSIGHT	9020A	MY55370835	A.17.05	Nov. 02, 2023	Nov. 01, 2024
2	Spectrum Analyzer (10kHz-39.9GHz)	R&S	FSV40-N	100363	1.71 SP2	Nov. 02, 2023	Nov. 01, 2024
3	EMI Test Receiver (9kHz-7GHz)	R&S	ESCI7	101169	4.32	Nov. 02, 2023	Nov. 01, 2024
4	Bilog Antenna (30MHz-1500MHz)	Schwarzbeck	VULB9168	N/A	N/A	Nov. 13, 2023	Nov. 12, 2024
5	Horn Antenna (1GHz-18GHz)	Agilent	AH-118	071145	N/A	Nov. 13, 2023	Nov. 12, 2024
6	Horn Antenna (15GHz-40GHz)	A.H.System	SAS-574	588	N/A	Nov. 13, 2023	Nov. 12, 2024
7	Loop Antenna	TESEQ	HLA6121	58357	N/A	Nov. 16, 2023	Nov. 15, 2024
8	Amplifier (30-1000MHz)	EM Electronics	EM330 Amplifier	060747	N/A	Nov. 02, 2023	Nov. 01, 2024
9	Amplifier (1GHz-26.5GHz)	Agilent	8449B	3008A00315	N/A	Nov. 02, 2023	Nov. 01, 2024
10	Amplifier (500MHz-40GHz)	QuanJuDa	DLE-161	097	N/A	Nov. 02, 2023	Nov. 01, 2024
11	Test Cable	N/A	R-01	N/A	N/A	Nov. 02, 2023	Nov. 01, 2024
12	Test Cable	N/A	R-02	N/A	N/A	Nov. 02, 2023	Nov. 01, 2024
13	Test Cable	N/A	R-03	N/A	N/A	Nov. 02, 2023	Nov. 01, 2024
14	D.C. Power Supply	LongWei	TPR-6405D	N/A	N/A	\	\
15	EMC Software	Frad	EZ-EMC	Ver.EMC-CO N 3A1.1	N/A	\	\
16	Turntable	MF	MF-7802BS	N/A	N/A	\	\
17	Antenna tower	MF	MF-7802BS	N/A	N/A	\	\



RF Test equipment

Item	Equipment	Manufacturer	Type No.	Serial No.	Firmware Version	Last calibration	Calibrated until
1	Spectrum Analyzer (9kHz-26.5GHz)	KEYSIGHT	9020A	MY55370835	A.17.05	Nov. 02, 2023	Nov. 01, 2024
2	Spectrum Analyzer (10kHz-39.9GHz)	R&S	FSV40-N	100363	1.71 SP2	Nov. 02, 2023	Nov. 01, 2024
3	Test Cable	N/A	RF-01	N/A	N/A	Nov. 02, 2023	Nov. 01, 2024
4	Test Cable	N/A	RF-02	N/A	N/A	Nov. 02, 2023	Nov. 01, 2024
5	Test Cable	N/A	RF-03	N/A	N/A	Nov. 02, 2023	Nov. 01, 2024
6	ESG Signal Generator	Agilent	E4421B	N/A	B.03.84	Nov. 02, 2023	Nov. 01, 2024
7	Signal Generator	Agilent	N5182A	N/A	A.01.87	Nov. 02, 2023	Nov. 01, 2024
8	Magnetic Field Probe Tester	Narda	ELT-400	0-0344	N/A	Nov. 16, 2023	Nov. 15, 2024
9	Wideband Radio Communication Test	R&S	CMW500	106504	V 3.7.22	Nov. 02, 2023	Nov. 01, 2024
10	MWRF Power Meter Test system	MW	MW100-RF CB	N/A	N/A	Nov. 02, 2023	Nov. 01, 2024
11	Power Meter	KEYSIGHT	N1912A P	N/A	A.05.00	Nov. 02, 2023	Nov. 01, 2024
12	D.C. Power Supply	LongWei	TPR-6405D	N/A	N/A	\	\
13	RF Software	MW	MTS8310	V2.0.0.0	N/A	\	\



4. EMC EMISSION TEST

4.1 CONDUCTED EMISSION MEASUREMENT

Test Requirement:	FCC Part15 C Section 15.207
Test Method:	ANSI C63.10:2013
Test Frequency Range:	150KHz to 30MHz
Receiver setup:	RBW=9KHz, VBW=30KHz, Sweep time=auto

4.1.1 POWER LINE CONDUCTED EMISSION Limits

FREQUENCY (MHz)	Limit (dBuV)		Standard
	Quasi-peak	Average	
0.15 -0.5	66 - 56 *	56 - 46 *	FCC
0.50 -5.0	56.00	46.00	FCC
5.0 -30.0	60.00	50.00	FCC

Note:

(1) *Decreases with the logarithm of the frequency.

4.1.2 TEST PROCEDURE

- The EUT was placed 0.8 meters from the horizontal ground plane with EUT being connected to the power mains through a line impedance stabilization network (LISN). All other support equipments powered from additional LISN(s). The LISN provide 50 Ohm/ 50uH of coupling impedance for the measuring instrument.
- Interconnecting cables that hang closer than 40 cm to the ground plane shall be folded back and forth in the center forming a bundle 30 to 40 cm long.
- I/O cables that are not connected to a peripheral shall be bundled in the center. The end of the cable may be terminated, if required, using the correct terminating impedance. The overall length shall not exceed 1 m.
- LISN at least 80 cm from nearest part of EUT chassis.
- For the actual test configuration, please refer to the related Item –EUT Test Photos.

4.1.3 DEVIATION FROM TEST STANDARD

No deviation



4.1.4 TEST SETUP

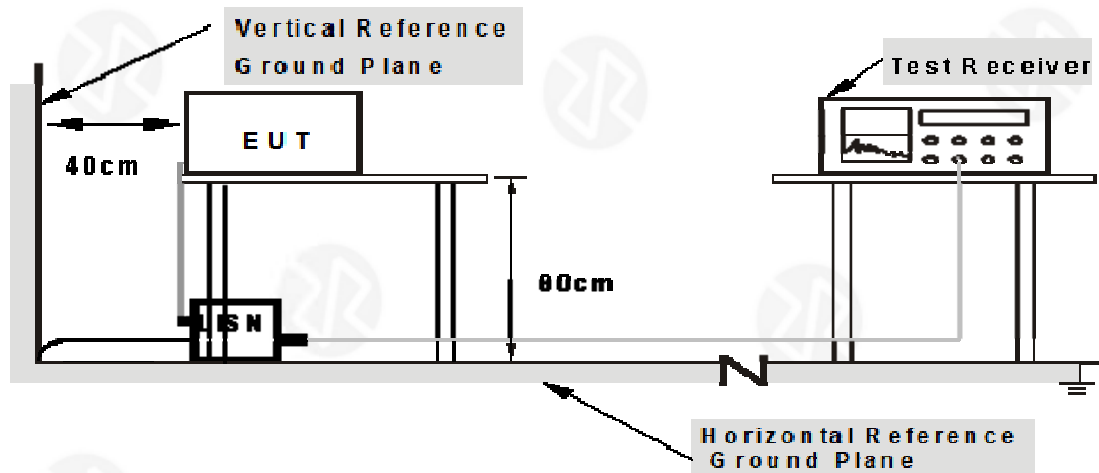

- Note:**
- 1.Support units were connected to second LISN.
 - 2.Both of LISNs (AMN) are 80 cm from EUT and at least 80 from other units and other metal planes

4.1.5 EUT OPERATING CONDITIONS

The EUT was configured for testing in a typical fashion (as a customer would normally use it). The EUT has been programmed to continuously transmit during test. This operating condition was tested and used to collect the included data.



4.1.6 TEST RESULT

Temperature:	26°C	Relative Humidity:	54%
Pressure:	101 kPa	Polarization:	L
Test Voltage:	AC 120V/60Hz	Test Mode:	TX 802.11b - 2412MHz

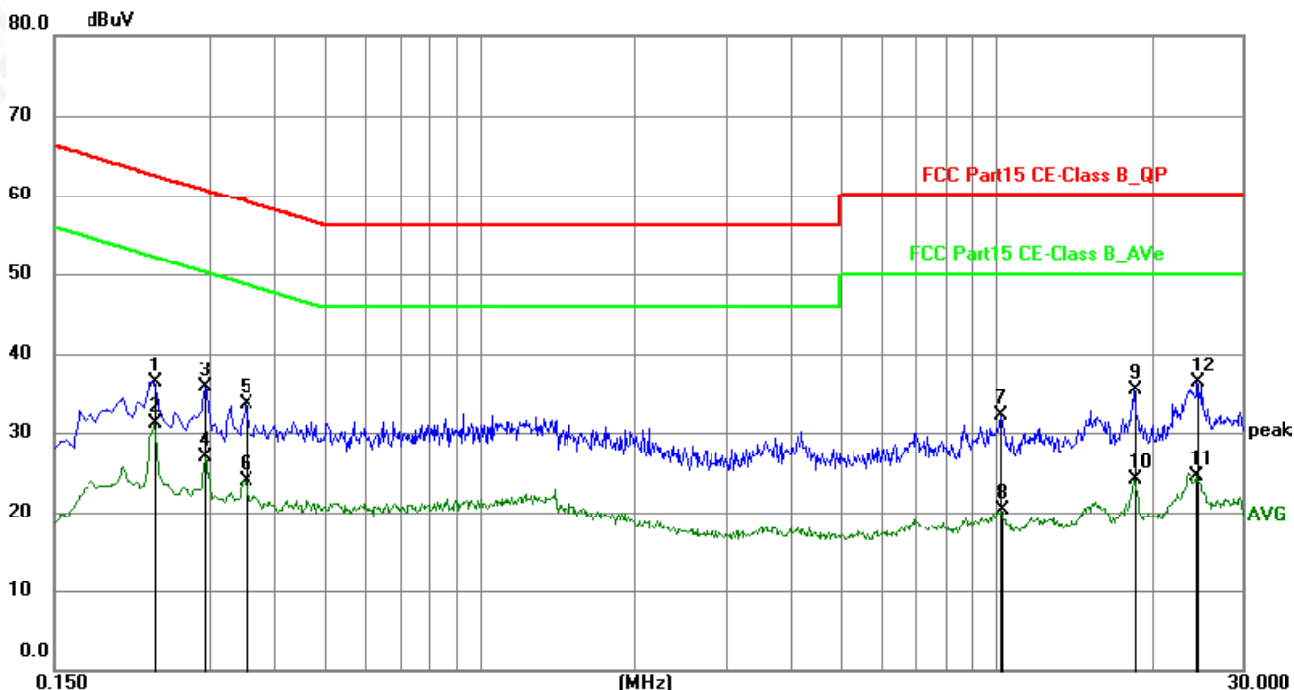

No.	Frequency (MHz)	Reading (dBuV)	Factor (dB)	Level (dBuV)	Limit (dBuV)	Margin (dB)	Detector	P/F	Remark
1	0.2354	15.31	21.02	36.33	62.26	-25.93	QP	P	
2	0.2354	10.02	21.02	31.04	52.26	-21.22	AVG	P	
3	0.2939	14.69	21.00	35.69	60.41	-24.72	QP	P	
4	0.2939	5.86	21.00	26.86	50.41	-23.55	AVG	P	
5	0.3524	12.48	20.97	33.45	58.91	-25.46	QP	P	
6	0.3524	2.91	20.97	23.88	48.91	-25.03	AVG	P	
7	10.2299	10.04	22.08	32.12	60.00	-27.88	QP	P	
8	10.2705	-1.85	22.08	20.23	50.00	-29.77	AVG	P	
9	18.5955	11.88	23.47	35.35	60.00	-24.65	QP	P	
10	18.5955	0.65	23.47	24.12	50.00	-25.88	AVG	P	
11	24.3644	0.09	24.41	24.50	50.00	-25.50	AVG	P	
12	24.5219	11.89	24.44	36.33	60.00	-23.67	QP	P	

Notes:

1. An initial pre-scan was performed on the line and neutral lines with peak detector.
2. Quasi-Peak and Average measurement were performed at the frequencies with maximized peak emission.
3. Final Level = Reading level + Correct Factor.
4. Correct Factor= Lism factor+ Cable loss factor + limiter factor.
5. Margin= Measurement Level-Limit.
6. The test data shows only the worst case TX 802.11b - 2412MHz.



Temperature:	26°C	Relative Humidity:	54%
Pressure:	101 kPa	Polarization:	N
Test Voltage:	AC 120V/60Hz	Test Mode:	TX 802.11b - 2412MHz

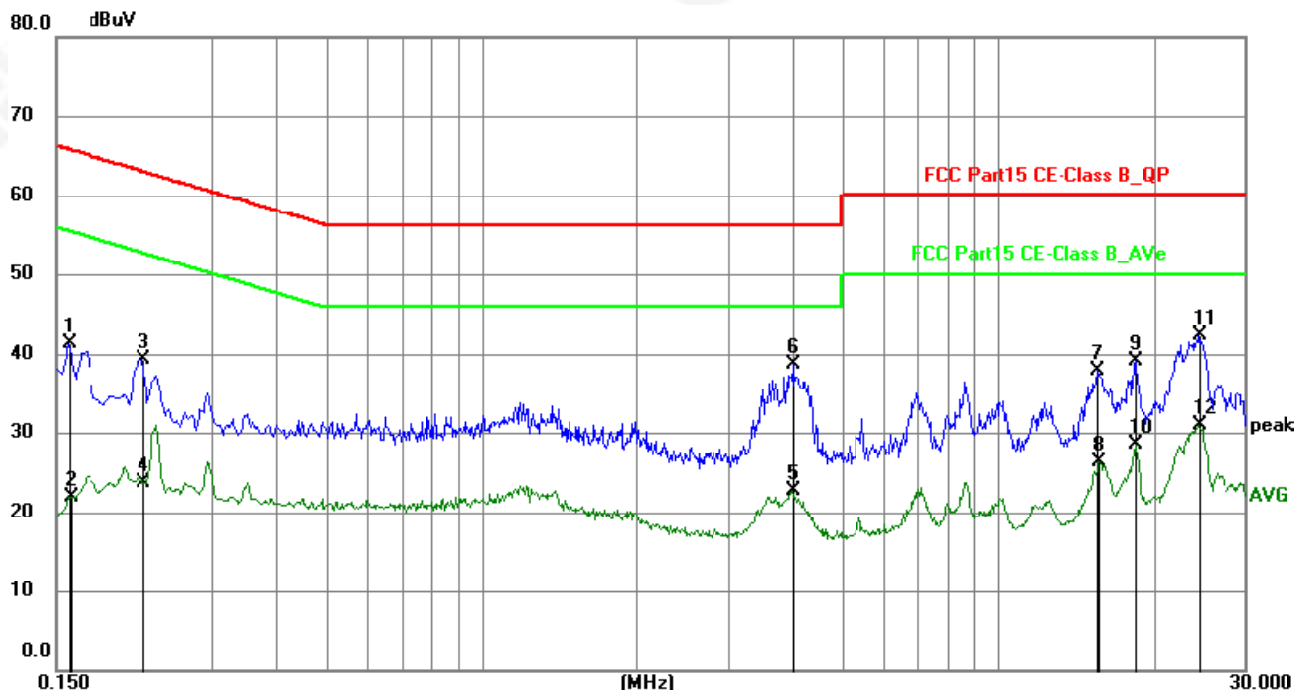

No.	Frequency (MHz)	Reading (dBuV)	Factor (dB)	Level (dBuV)	Limit (dBuV)	Margin (dB)	Detector	P/F	Remark
1	0.1590	20.48	20.87	41.35	65.52	-24.17	QP	P	
2	0.1598	0.98	20.87	21.85	55.47	-33.62	AVG	P	
3	0.2220	18.41	20.99	39.40	62.74	-23.34	QP	P	
4	0.2220	2.62	20.99	23.61	52.74	-29.13	AVG	P	
5	3.9930	1.51	21.11	22.62	46.00	-23.38	AVG	P	
6	4.0200	17.56	21.11	38.67	56.00	-17.33	QP	P	
7	15.5940	14.90	23.02	37.92	60.00	-22.08	QP	P	
8	15.7110	3.27	23.03	26.30	50.00	-23.70	AVG	P	
9	18.5190	15.49	23.52	39.01	60.00	-20.99	QP	P	
10	18.5190	4.90	23.52	28.42	50.00	-21.58	AVG	P	
11	24.4950	17.86	24.48	42.34	60.00	-17.66	QP	P	
12	24.4950	6.44	24.48	30.92	50.00	-19.08	AVG	P	

Notes:

1. An initial pre-scan was performed on the line and neutral lines with peak detector.
2. Quasi-Peak and Average measurement were performed at the frequencies with maximized peak emission.
3. Final Level = Reading level + Correct Factor.
4. Correct Factor= Lism factor+ Cable loss factor + limiter factor.
5. Margin= Measurement Level-Limit.
6. The test data shows only the worst case TX 802.11b - 2412MHz.



4.2 RADIATED EMISSION MEASUREMENT

Test Requirement:	FCC Part15 C Section 15.209				
Test Method:	ANSI C63.10:2013				
Test Frequency Range:	9kHz to 25GHz				
Test site:	Measurement Distance: 3m				
Receiver setup:	Frequency	Detector	RBW	VBW	Value
	9KHz-150KHz	Quasi-peak	200Hz	600Hz	Quasi-peak
	150KHz-30MHz	Quasi-peak	9KHz	30KHz	Quasi-peak
	30MHz-1GHz	Quasi-peak	100KHz	300KHz	Quasi-peak
	Above 1GHz	Peak	1MHz	3MHz	Peak
Peak		1MHz	10Hz	Average	

4.2.1 RADIATED EMISSION LIMITS

Frequencies (MHz)	Field Strength (microlvolts/meter)	Measurement Distance (meters)
0.009~0.490	2400/F(KHz)	300
0.490~1.705	24000/F(KHz)	30
1.705~30.0	30	30
30~88	100	3
88~216	150	3
216~960	200	3
Above 960	500	3

LIMITS OF RADIATED EMISSION MEASUREMENT

FREQUENCY (MHz)	Limit (dBuV/m) (at 3M)	
	PEAK	AVERAGE
Above 1000	74	54

Notes:

- (1) The limit for radiated test was performed according to FCC PART 15C.
- (2) The tighter limit applies at the band edges.
- (3) Emission level (dBuV/m)=20log Emission level (uV/m).

4.2.2 TEST PROCEDURE

Below 1GHz test procedure as below:

- a. The EUT was placed on the top of a rotating table 0.8 meters above the ground at a 3 meter semi-anechoic chamber. The table was rotated 360 degrees to determine the position of the highest radiation.
- b. The EUT was set 3 meters away from the interference-receiving antenna, which was mounted on the top of available-height antenna tower.



- c. The antenna height is varied from one meter to four meters above the ground to determine the maximum value of the field strength. Both horizontal and vertical polarizations of the antenna are set to make the measurement.
- d. For each suspected emission, the EUT was arranged to its worst case and then the antenna was tuned to heights from 1 meter to 4 meters (for the test frequency of below 30MHz, the antenna was tuned to heights 1 meter) and the rotatable table was turned from 0 degrees to 360 degrees to find the maximum reading.
- e. The test-receiver system was set to Peak Detect Function and Specified Bandwidth with Maximum Hold Mode.
- f. If the emission level of the EUT in peak mode was 10dB lower than the limit specified, then testing could be stopped and the peak values of the EUT would be reported. Otherwise the emissions that did not have 10dB margin would be re-tested one by one using peak, quasi-peak or average method as specified and then reported in a data sheet.

Above 1GHz test procedure as below:

- g. Different from above is the test site, change from Semi- Anechoic Chamber to fully Anechoic Chamber and change from table 0.8 meter to 1.5 meter (Above 18GHz the distance is 1 meter and table is 1.5 meter).
- h. Test the EUT in the lowest channel, the middle channel, the Highest channel

Note:

Both horizontal and vertical antenna polarities were tested and performed pretest to three orthogonal axis. The worst case emissions were reported

4.2.3 DEVIATION FROM TEST STANDARD

No deviation

4.2.4 TEST SETUP

(A) Radiated Emission Test-Up Frequency Below 30MHz

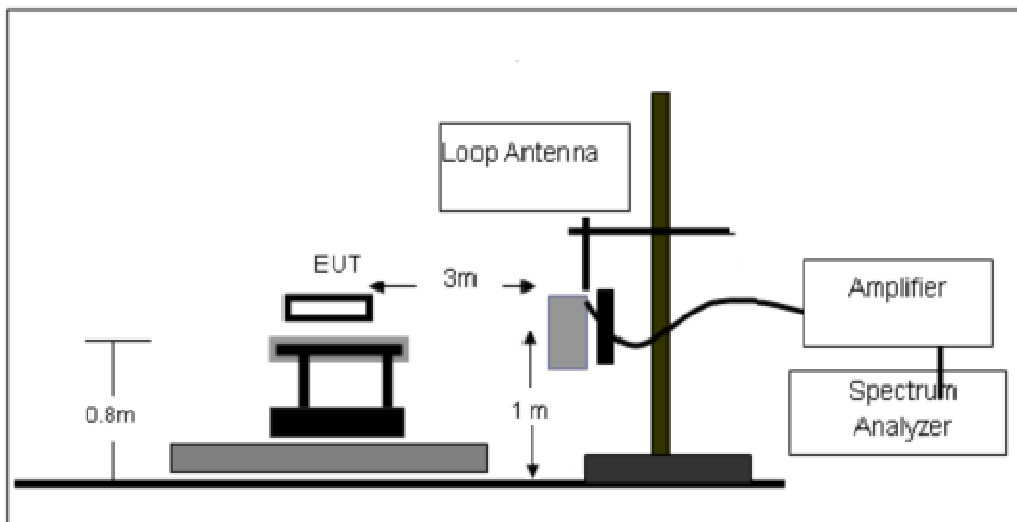



(B) Radiated Emission Test-Up Frequency 30MHz~1GHz

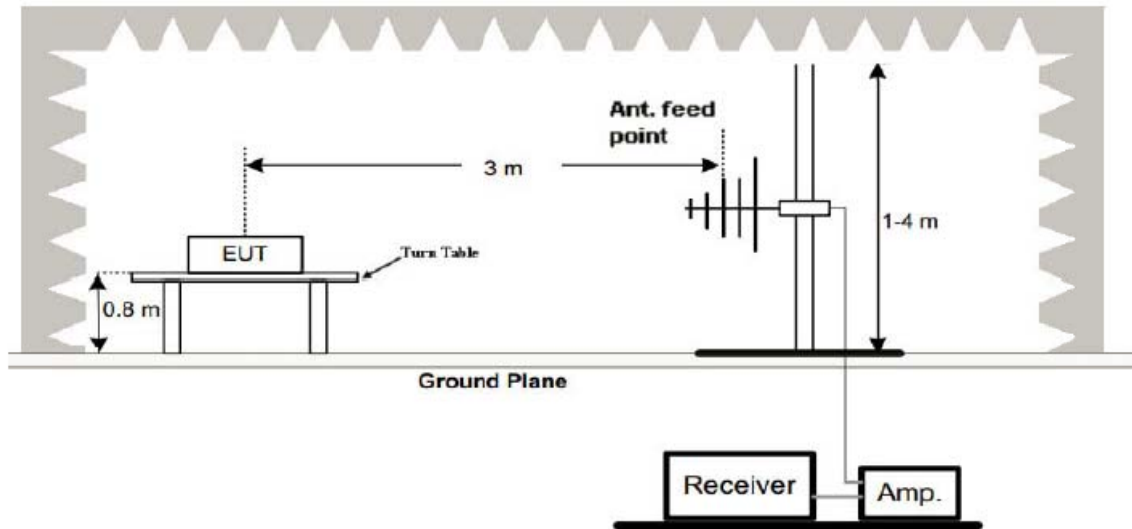

(C) Radiated Emission Test-Up Frequency Above 1GHz

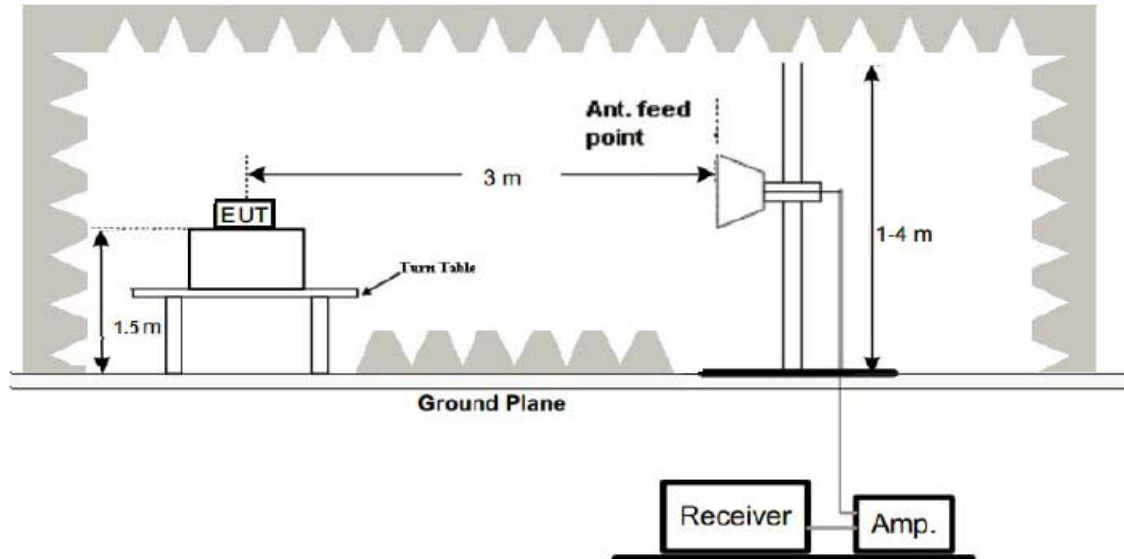

4.2.5 EUT OPERATING CONDITIONS

The EUT tested system was configured as the statements of 2.4 Unless otherwise a special operating condition is specified in the follows during the testing.

4.2.6 TEST RESULTS

Between 9KHz – 30MHz

The emission from 9 kHz to 30MHz was pre-tested and found the result was 20dB lower than the limit, and according to 15.31(o) & RSS-Gen 6.13, the test result no need to reported.



Between 30MHz – 1GHz

Temperature:	26°C	Relative Humidity:	54%
Pressure:	101 kPa	Polarization:	Horizontal
Test Voltage:	DC 3.7V	Test Mode :	TX 802.11b - 2412MHz

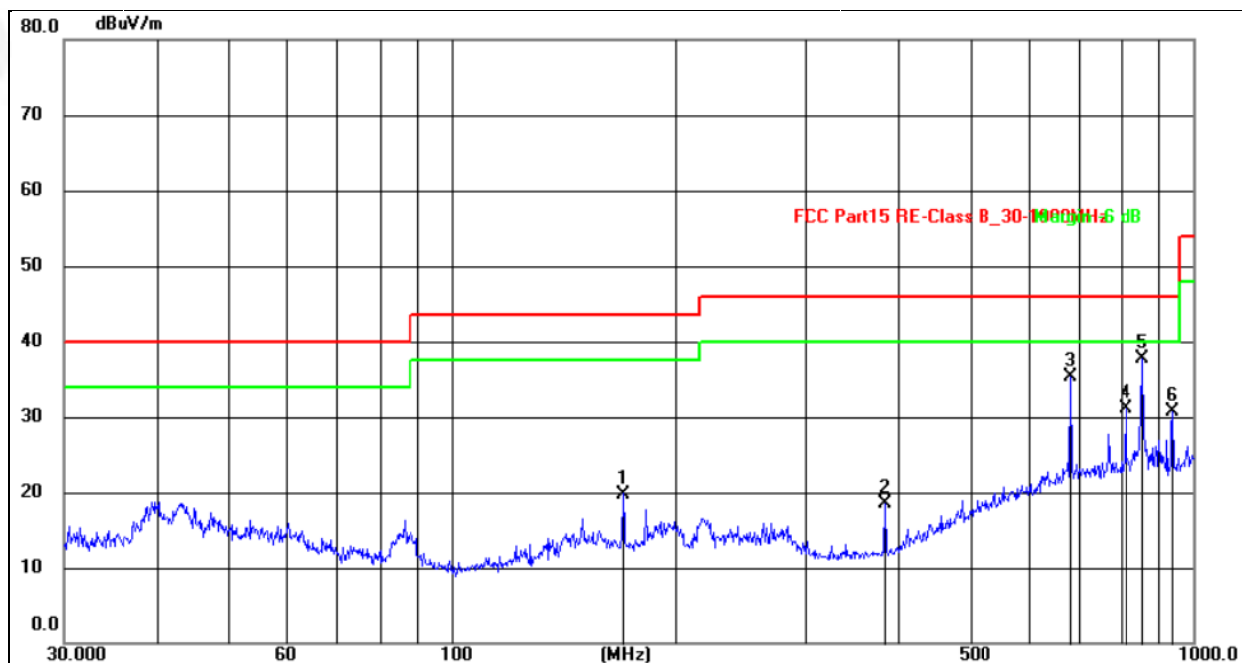

No.	Frequency (MHz)	Reading (dBuV)	Factor (dB/m)	Level (dBuV/m)	Limit (dBuV/m)	Margin (dB)	Detector
1	170.1947	36.84	-17.04	19.80	43.50	-23.70	QP
2	383.9318	35.10	-16.63	18.47	46.00	-27.53	QP
3	682.3482	42.36	-7.07	35.29	46.00	-10.71	QP
4	810.2653	38.08	-6.95	31.13	46.00	-14.87	QP
5	854.0247	44.66	-6.97	37.69	46.00	-8.31	QP
6	938.8324	36.80	-6.16	30.64	46.00	-15.36	QP

Remarks:

1. An initial pre-scan was performed on the peak detector.
2. Quasi-Peak measurement were performed at the frequencies with maximized peak emission.
3. The emission levels of other frequencies are very lower than the limit and not show in test report.
4. Final Level = Reading level + Correct Factor.
5. Correct Factor= Antenna factor+ Cable loss factor - Amplifier factor.
6. Margin= Measurement Level-Limit.
7. The test data shows only the worst case TX 802.11b - 2412MHz.



Temperature:	26°C	Relative Humidity:	54%
Pressure:	101kPa	Polarization:	Vertical
Test Voltage:	DC 3.7V	Test Mode :	TX 802.11b - 2412MHz

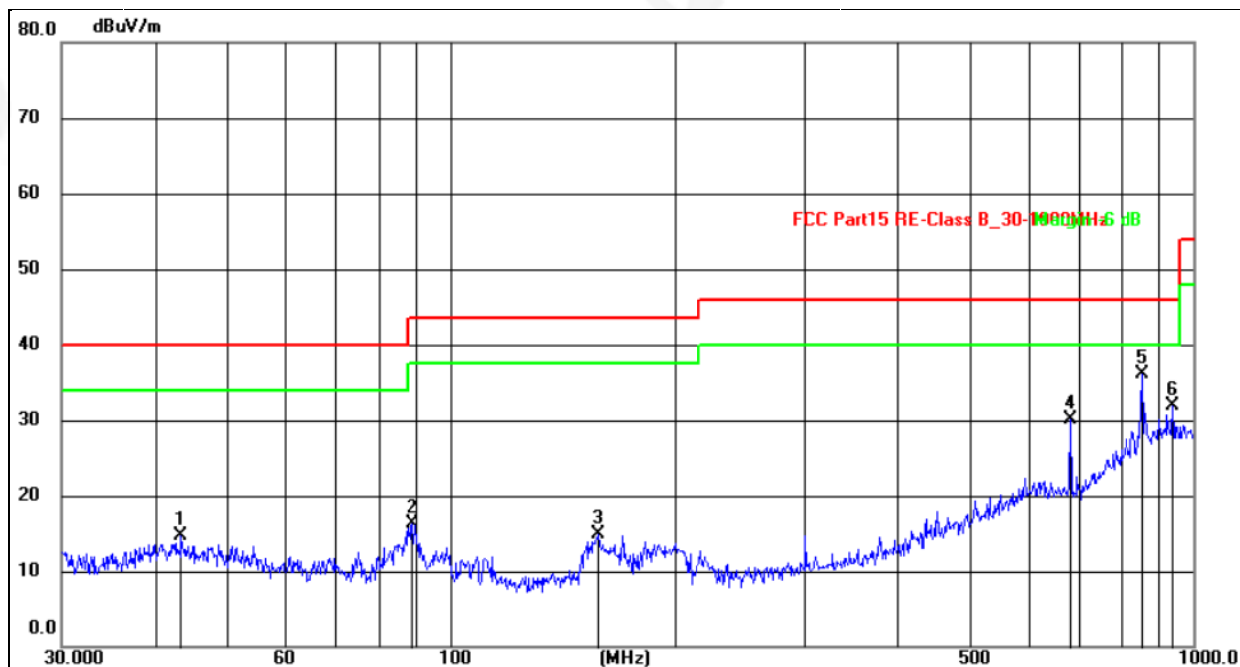

No.	Frequency (MHz)	Reading (dBuV)	Factor (dB/m)	Level (dBuV/m)	Limit (dBuV/m)	Margin (dB)	Detector
1	43.3534	31.71	-17.01	14.70	40.00	-25.30	QP
2	88.9637	37.85	-21.54	16.31	43.50	-27.19	QP
3	158.1123	35.07	-20.26	14.81	43.50	-28.69	QP
4	682.3482	37.71	-7.66	30.05	46.00	-15.95	QP
5	854.0247	38.20	-2.04	36.16	46.00	-9.84	QP
6	938.8324	32.36	-0.53	31.83	46.00	-14.17	QP

Remarks:

1. An initial pre-scan was performed on the peak detector.
2. Quasi-Peak measurement were performed at the frequencies with maximized peak emission.
3. The emission levels of other frequencies are very lower than the limit and not show in test report.
4. Final Level = Reading level + Correct Factor.
5. Correct Factor= Antenna factor+ Cable loss factor - Amplifier factor.
6. Margin= Measurement Level-Limit.
7. The test data shows only the worst case TX 802.11b - 2412MHz.



1GHz~25GHz

802.11b

Polar (H/V)	Frequency	Meter Reading	Pre-ampl ifier	Cable Loss	Antenna Factor	Emission Level	Limits	Margin	Detect or Type
	(MHz)	(dBuV)	(dB)	(dB)	(dB)	(dBuV/m)	(dBuV/ m)	(dB)	
Low Channel:2412MHz									
V	4824.00	54.16	30.55	5.77	24.66	54.04	74.00	-19.96	PK
V	4824.00	43.90	30.55	5.77	24.66	43.78	54.00	-10.22	AV
V	7236.00	54.64	30.33	6.32	24.55	55.18	74.00	-18.82	PK
V	7236.00	43.84	30.33	6.32	24.55	44.38	54.00	-9.62	AV
V	9648.00	50.25	30.85	7.45	24.69	51.54	74.00	-22.46	PK
V	9648.00	44.00	30.85	7.45	24.69	45.29	54.00	-8.71	AV
V	12060.00	52.44	31.02	8.99	25.57	55.98	74.00	-18.02	PK
V	12060.00	43.21	31.02	8.99	25.57	46.75	54.00	-7.25	AV
H	4824.00	51.83	30.55	5.77	24.66	51.71	74.00	-22.29	PK
H	4824.00	43.30	30.55	5.77	24.66	43.18	54.00	-10.82	AV
H	7236.00	53.74	30.33	6.32	24.55	54.28	74.00	-19.72	PK
H	7236.00	43.62	30.33	6.32	24.55	44.16	54.00	-9.84	AV
H	9648.00	54.08	30.85	7.45	24.69	55.37	74.00	-18.63	PK
H	9648.00	43.86	30.85	7.45	24.69	45.15	54.00	-8.85	AV
H	12060.00	54.37	31.02	8.99	25.57	57.91	74.00	-16.09	PK
H	12060.00	43.26	31.02	8.99	25.57	46.80	54.00	-7.20	AV

Polar (H/V)	Frequency	Meter Reading	Pre-ampl ifier	Cable Loss	Antenna Factor	Emission Level	Limits	Margin	Detect or Type
	(MHz)	(dBuV)	(dB)	(dB)	(dB)	(dBuV/m)	(dBuV/ m)	(dB)	
Middle Channel:2437MHz									
V	4874.00	52.16	30.55	5.77	24.66	52.04	74.00	-21.96	PK
V	4874.00	43.90	30.55	5.77	24.66	43.78	54.00	-10.22	AV
V	7311.00	51.23	30.33	6.32	24.55	51.77	74.00	-22.23	PK
V	7311.00	43.60	30.33	6.32	24.55	44.14	54.00	-9.86	AV
V	9748.00	52.69	30.85	7.45	24.69	53.98	74.00	-20.02	PK
V	9748.00	43.87	30.85	7.45	24.69	45.16	54.00	-8.84	AV
V	12185.00	54.95	31.02	8.99	25.57	58.49	74.00	-15.51	PK
V	12185.00	43.89	31.02	8.99	25.57	47.43	54.00	-6.57	AV
H	4874.00	54.98	30.55	5.77	24.66	54.86	74.00	-19.14	PK
H	4874.00	43.09	30.55	5.77	24.66	42.97	54.00	-11.03	AV
H	7311.00	54.79	30.33	6.32	24.55	55.33	74.00	-18.67	PK
H	7311.00	43.14	30.33	6.32	24.55	43.68	54.00	-10.32	AV
H	9748.00	51.18	30.85	7.45	24.69	52.47	74.00	-21.53	PK
H	9748.00	43.01	30.85	7.45	24.69	44.30	54.00	-9.70	AV
H	12185.00	54.34	31.02	8.99	25.57	57.88	74.00	-16.12	PK
H	12185.00	43.27	31.02	8.99	25.57	46.81	54.00	-7.19	AV



Polar (H/V)	Frequency	Meter Reading	Pre-ampli fier	Cable Loss	Antenna Factor	Emission Level	Limits	Margin	Detect or Type
	(MHz)	(dBuV)	(dB)	(dB)	(dB)	(dBuV/m)	(dBuV/ m)	(dB)	
High Channel:2462MHz									
V	4924.00	52.60	30.55	5.77	24.66	52.48	74.00	-21.52	PK
V	4924.00	43.32	30.55	5.77	24.66	43.20	54.00	-10.80	AV
V	7386.00	52.80	30.33	6.32	24.55	53.34	74.00	-20.66	PK
V	7386.00	43.14	30.33	6.32	24.55	43.68	54.00	-10.32	AV
V	9848.00	53.02	30.85	7.45	24.69	54.31	74.00	-19.69	PK
V	9848.00	43.76	30.85	7.45	24.69	45.05	54.00	-8.95	AV
V	12310.00	52.94	31.02	8.99	25.57	56.48	74.00	-17.52	PK
V	12310.00	43.68	31.02	8.99	25.57	47.22	54.00	-6.78	AV
H	4924.00	53.92	30.55	5.77	24.66	53.80	74.00	-20.20	PK
H	4924.00	43.19	30.55	5.77	24.66	43.07	54.00	-10.93	AV
H	7386.00	54.02	30.33	6.32	24.55	54.56	74.00	-19.44	PK
H	7386.00	43.02	30.33	6.32	24.55	43.56	54.00	-10.44	AV
H	9848.00	52.83	30.85	7.45	24.69	54.12	74.00	-19.88	PK
H	9848.00	43.89	30.85	7.45	24.69	45.18	54.00	-8.82	AV
H	12310.00	50.36	31.02	8.99	25.57	53.90	74.00	-20.10	PK
H	12310.00	43.63	31.02	8.99	25.57	47.17	54.00	-6.83	AV

Remark:

1. Emission Level = Meter Reading + Antenna Factor + Cable Loss – Pre-amplifier, Margin= Emission Level - Limit
2. If peak below the average limit, the average emission was no test.
3. The amplitude of spurious emissions which are attenuated by more than 20dB below the permissible value has no need to be reported.



802.11g

Polar (H/V)	Frequency	Meter Reading	Pre-ampl ifier	Cable Loss	Antenna Factor	Emission Level	Limits	Margin	Detect or Type
	(MHz)	(dBuV)	(dB)	(dB)	(dB)	(dBuV/m)	(dBuV/ m)	(dB)	
Low Channel:2412MHz									
V	4824.00	53.90	30.55	5.77	24.66	53.78	74.00	-20.22	PK
V	4824.00	43.49	30.55	5.77	24.66	43.37	54.00	-10.63	AV
V	7236.00	52.49	30.33	6.32	24.55	53.03	74.00	-20.97	PK
V	7236.00	43.55	30.33	6.32	24.55	44.09	54.00	-9.91	AV
V	9648.00	53.15	30.85	7.45	24.69	54.44	74.00	-19.56	PK
V	9648.00	43.25	30.85	7.45	24.69	44.54	54.00	-9.46	AV
V	12060.00	52.70	31.02	8.99	25.57	56.24	74.00	-17.76	PK
V	12060.00	43.52	31.02	8.99	25.57	47.06	54.00	-6.94	AV
H	4824.00	50.41	30.55	5.77	24.66	50.29	74.00	-23.71	PK
H	4824.00	43.98	30.55	5.77	24.66	43.86	54.00	-10.14	AV
H	7236.00	54.93	30.33	6.32	24.55	55.47	74.00	-18.53	PK
H	7236.00	43.68	30.33	6.32	24.55	44.22	54.00	-9.78	AV
H	9648.00	52.39	30.85	7.45	24.69	53.68	74.00	-20.32	PK
H	9648.00	43.64	30.85	7.45	24.69	44.93	54.00	-9.07	AV
H	12060.00	51.81	31.02	8.99	25.57	55.35	74.00	-18.65	PK
H	12060.00	43.43	31.02	8.99	25.57	46.97	54.00	-7.03	AV

Polar (H/V)	Frequency	Meter Reading	Pre-ampl ifier	Cable Loss	Antenna Factor	Emission Level	Limits	Margin	Detect or Type
	(MHz)	(dBuV)	(dB)	(dB)	(dB)	(dBuV/m)	(dBuV/ m)	(dB)	
Middle Channel:2437MHz									
V	4874.00	53.67	30.55	5.77	24.66	53.55	74.00	-20.45	PK
V	4874.00	43.48	30.55	5.77	24.66	43.36	54.00	-10.64	AV
V	7311.00	53.67	30.33	6.32	24.55	54.21	74.00	-19.79	PK
V	7311.00	43.65	30.33	6.32	24.55	44.19	54.00	-9.81	AV
V	9748.00	50.85	30.85	7.45	24.69	52.14	74.00	-21.86	PK
V	9748.00	43.04	30.85	7.45	24.69	44.33	54.00	-9.67	AV
V	12185.00	52.33	31.02	8.99	25.57	55.87	74.00	-18.13	PK
V	12185.00	43.19	31.02	8.99	25.57	46.73	54.00	-7.27	AV
H	4874.00	54.13	30.55	5.77	24.66	54.01	74.00	-19.99	PK
H	4874.00	43.72	30.55	5.77	24.66	43.60	54.00	-10.40	AV
H	7311.00	51.23	30.33	6.32	24.55	51.77	74.00	-22.23	PK
H	7311.00	43.58	30.33	6.32	24.55	44.12	54.00	-9.88	AV
H	9748.00	51.15	30.85	7.45	24.69	52.44	74.00	-21.56	PK
H	9748.00	43.65	30.85	7.45	24.69	44.94	54.00	-9.06	AV
H	12185.00	53.51	31.02	8.99	25.57	57.05	74.00	-16.95	PK
H	12185.00	43.02	31.02	8.99	25.57	46.56	54.00	-7.44	AV



Polar (H/V)	Frequency	Meter Reading	Pre-ampl ifier	Cable Loss	Antenna Factor	Emission Level	Limits	Margin	Detect or Type
	(MHz)	(dBuV)	(dB)	(dB)	(dB)	(dBuV/m)	(dBuV/ m)	(dB)	
High Channel:2462MHz									
V	4924.00	54.74	30.55	5.77	24.66	54.62	74.00	-19.38	PK
V	4924.00	43.76	30.55	5.77	24.66	43.64	54.00	-10.36	AV
V	7386.00	53.47	30.33	6.32	24.55	54.01	74.00	-19.99	PK
V	7386.00	43.08	30.33	6.32	24.55	43.62	54.00	-10.38	AV
V	9848.00	54.58	30.85	7.45	24.69	55.87	74.00	-18.13	PK
V	9848.00	43.09	30.85	7.45	24.69	44.38	54.00	-9.62	AV
V	12310.00	50.19	31.02	8.99	25.57	53.73	74.00	-20.27	PK
V	12310.00	43.78	31.02	8.99	25.57	47.32	54.00	-6.68	AV
H	4924.00	54.84	30.55	5.77	24.66	54.72	74.00	-19.28	PK
H	4924.00	43.63	30.55	5.77	24.66	43.51	54.00	-10.49	AV
H	7386.00	50.39	30.33	6.32	24.55	50.93	74.00	-23.07	PK
H	7386.00	43.18	30.33	6.32	24.55	43.72	54.00	-10.28	AV
H	9848.00	54.28	30.85	7.45	24.69	55.57	74.00	-18.43	PK
H	9848.00	43.14	30.85	7.45	24.69	44.43	54.00	-9.57	AV
H	12310.00	53.26	31.02	8.99	25.57	56.80	74.00	-17.20	PK
H	12310.00	43.44	31.02	8.99	25.57	46.98	54.00	-7.02	AV

Remark:

1. Emission Level = Meter Reading + Antenna Factor + Cable Loss – Pre-amplifier,

Margin= Emission Level - Limit

2. If peak below the average limit, the average emission was no test.

3. The amplitude of spurious emissions which are attenuated by more than 20dB below the permissible value has no need to be reported.



802.11n20

Polar (H/V)	Frequency	Meter Reading	Pre-amplifier	Cable Loss	Antenna Factor	Emission Level	Limits	Margin	Detect or Type
	(MHz)	(dBuV)	(dB)	(dB)	(dB)	(dBuV/m)	(dBuV/m)	(dB)	
Low Channel:2412MHz									
V	4824.00	52.88	30.55	5.77	24.66	52.76	74.00	-21.24	PK
V	4824.00	43.74	30.55	5.77	24.66	43.62	54.00	-10.38	AV
V	7236.00	50.20	30.33	6.32	24.55	50.74	74.00	-23.26	PK
V	7236.00	43.20	30.33	6.32	24.55	43.74	54.00	-10.26	AV
V	9648.00	52.55	30.85	7.45	24.69	53.84	74.00	-20.16	PK
V	9648.00	43.34	30.85	7.45	24.69	44.63	54.00	-9.37	AV
V	12060.00	54.90	31.02	8.99	25.57	58.44	74.00	-15.56	PK
V	12060.00	43.33	31.02	8.99	25.57	46.87	54.00	-7.13	AV
H	4824.00	52.96	30.55	5.77	24.66	52.84	74.00	-21.16	PK
H	4824.00	43.76	30.55	5.77	24.66	43.64	54.00	-10.36	AV
H	7236.00	54.01	30.33	6.32	24.55	54.55	74.00	-19.45	PK
H	7236.00	43.70	30.33	6.32	24.55	44.24	54.00	-9.76	AV
H	9648.00	54.57	30.85	7.45	24.69	55.86	74.00	-18.14	PK
H	9648.00	43.55	30.85	7.45	24.69	44.84	54.00	-9.16	AV
H	12060.00	50.40	31.02	8.99	25.57	53.94	74.00	-20.06	PK
H	12060.00	43.88	31.02	8.99	25.57	47.42	54.00	-6.58	AV

Polar (H/V)	Frequency	Meter Reading	Pre-amplifier	Cable Loss	Antenna Factor	Emission Level	Limits	Margin	Detect or Type
	(MHz)	(dBuV)	(dB)	(dB)	(dB)	(dBuV/m)	(dBuV/m)	(dB)	
Middle Channel:2437MHz									
V	4874.00	50.35	30.55	5.77	24.66	50.23	74.00	-23.77	PK
V	4874.00	43.85	30.55	5.77	24.66	43.73	54.00	-10.27	AV
V	7311.00	52.46	30.33	6.32	24.55	53.00	74.00	-21.00	PK
V	7311.00	43.83	30.33	6.32	24.55	44.37	54.00	-9.63	AV
V	9748.00	54.80	30.85	7.45	24.69	56.09	74.00	-17.91	PK
V	9748.00	43.20	30.85	7.45	24.69	44.49	54.00	-9.51	AV
V	12185.00	54.02	31.02	8.99	25.57	57.56	74.00	-16.44	PK
V	12185.00	43.51	31.02	8.99	25.57	47.05	54.00	-6.95	AV
H	4874.00	52.81	30.55	5.77	24.66	52.69	74.00	-21.31	PK
H	4874.00	43.41	30.55	5.77	24.66	43.29	54.00	-10.71	AV
H	7311.00	54.90	30.33	6.32	24.55	55.44	74.00	-18.56	PK
H	7311.00	43.95	30.33	6.32	24.55	44.49	54.00	-9.51	AV
H	9748.00	54.63	30.85	7.45	24.69	55.92	74.00	-18.08	PK
H	9748.00	43.06	30.85	7.45	24.69	44.35	54.00	-9.65	AV
H	12185.00	53.41	31.02	8.99	25.57	56.95	74.00	-17.05	PK
H	12185.00	43.03	31.02	8.99	25.57	46.57	54.00	-7.43	AV



Polar (H/V)	Frequency	Meter Reading	Pre-ampl ifier	Cable Loss	Antenna Factor	Emission Level	Limits	Margin	Detect or Type
	(MHz)	(dBuV)	(dB)	(dB)	(dB)	(dBuV/m)	(dBuV/ m)	(dB)	
High Channel:2462MHz									
V	4924.00	52.46	30.55	5.77	24.66	52.34	74.00	-21.66	PK
V	4924.00	43.58	30.55	5.77	24.66	43.46	54.00	-10.54	AV
V	7386.00	51.60	30.33	6.32	24.55	52.14	74.00	-21.86	PK
V	7386.00	43.39	30.33	6.32	24.55	43.93	54.00	-10.07	AV
V	9848.00	52.64	30.85	7.45	24.69	53.93	74.00	-20.07	PK
V	9848.00	43.66	30.85	7.45	24.69	44.95	54.00	-9.05	AV
V	12310.00	51.11	31.02	8.99	25.57	54.65	74.00	-19.35	PK
V	12310.00	43.42	31.02	8.99	25.57	46.96	54.00	-7.04	AV
H	4924.00	51.42	30.55	5.77	24.66	51.30	74.00	-22.70	PK
H	4924.00	43.54	30.55	5.77	24.66	43.42	54.00	-10.58	AV
H	7386.00	52.11	30.33	6.32	24.55	52.65	74.00	-21.35	PK
H	7386.00	43.60	30.33	6.32	24.55	44.14	54.00	-9.86	AV
H	9848.00	54.26	30.85	7.45	24.69	55.55	74.00	-18.45	PK
H	9848.00	43.25	30.85	7.45	24.69	44.54	54.00	-9.46	AV
H	12310.00	53.95	31.02	8.99	25.57	57.49	74.00	-16.51	PK
H	12310.00	43.75	31.02	8.99	25.57	47.29	54.00	-6.71	AV

Remark:

1. Emission Level = Meter Reading + Antenna Factor + Cable Loss – Pre-amplifier,

Margin= Emission Level - Limit

2. If peak below the average limit, the average emission was no test.

3. The amplitude of spurious emissions which are attenuated by more than 20dB below the permissible value has no need to be reported.



5. RADIATED BANDEMISSIONMEASUREMENT

5.1 TEST REQUIREMENT

Test Requirement:	FCC Part15 C Section 15.209 and 15.205				
Test Method:	ANSI C63.10: 2013				
Test Frequency Range:	All of the restrict bands were tested, only the worst band's (2390MHz to 2500MHz) data was showed.				
Test site:	Measurement Distance: 3m				
Receiver setup:	Frequency	Detector	RBW	VBW	Value
	Above 1GHz	Peak	1MHz	3MHz	Peak
		Average	1MHz	3MHz	Average

LIMITS OF RADIATED EMISSION MEASUREMENT (Above 1000MHz)

FREQUENCY (MHz)	Class B (dBuV/m) (at 3M)	
	PEAK	AVERAGE
Above 1000	74	54

Notes:

- (1) The limit for radiated test was performed according to FCC PART 15C.
- (2) The tighter limit applies at the band edges.
- (3) Emission level (dBuV/m)=20log Emission level (uV/m).

5.2 TEST PROCEDURE

Above 1GHz test procedure as below:

- a. 1. The EUT was placed on the top of a rotating table 0.8 meters above the ground at a 3 meter camber. The table was rotated 360 degrees to determine the position of the highest radiation.
- b. The EUT was set 3 meters away from the interference-receiving antenna, which was mounted on the top of a variable-height antenna tower.
- c. The antenna height is varied from one meter to four meters above the ground to determine the maximum value of the field strength. Both horizontal and vertical polarizations of the antenna are set to make the measurement.
- d. For each suspected emission, the EUT was arranged to its worst case and then the antenna was tuned to heights from 1 meter to 4 meters and the rota table was turned from 0 degrees to 360 degrees to find the maximum reading.
- e. The test-receiver system was set to Peak Detect Function and Specified Bandwidth with Maximum Hold Mode.
- f. If the emission level of the EUT in peak mode was 10dB lower than the limit specified, then testing could bestopped and the peak values of the EUT would be reported. Otherwise the emissions that did not have 10dBmargin would be re-tested one by one using peak, quasi-peak or average method as specified and then reportedin a data sheet.
- g. Test the EUT in the lowest channel,the Highest channel

Note:

Both horizontal and vertical antenna polarities were tested and performed pretest to three orthogonal axis. The worst case emissions were reported

5.3 DEVIATION FROM TEST STANDARD

No deviation



5.4 TEST SETUP

Radiated Emission Test-Up Frequency Above 1GHz

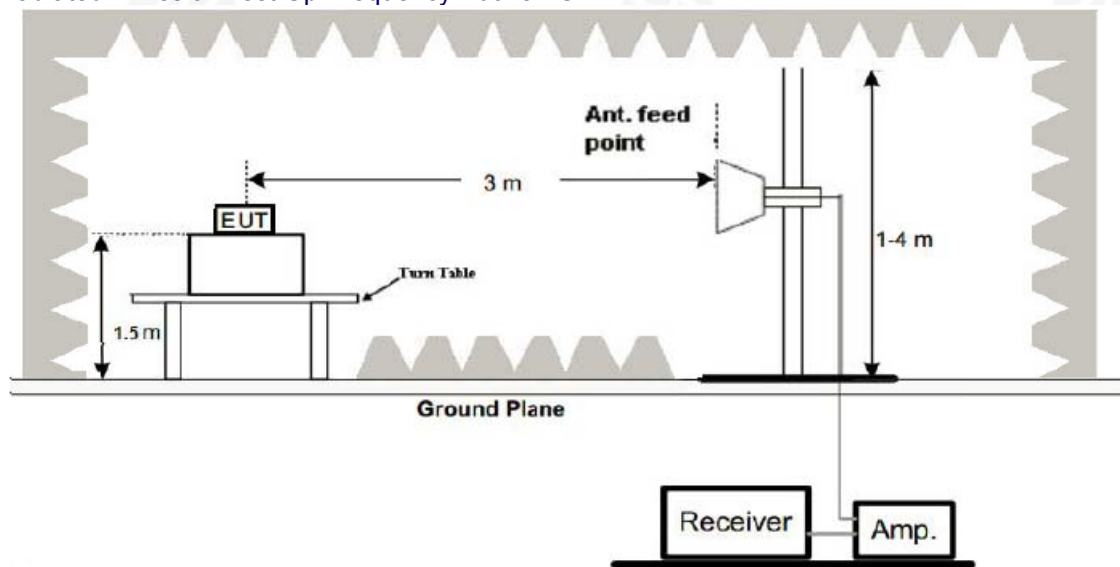

5.5 EUT OPERATING CONDITIONS

The EUT tested system was configured as the statements of 2.3 Unless otherwise a special operating condition is specified in the follows during the testing.



5.6 TEST RESULT

	Polar (H/V)	Frequency (MHz)	Meter Reading (dBuV)	Pre-amplifier (dB)	Cable Loss (dB)	Antenna Factor (dB/m)	Emission level (dBuV/m)	Limit (dBuV/m)	Margin (dB)	Detector Type	Result
802.11b	Low Channel 2412MHz										
	H	2390.00	53.69	30.22	4.85	23.98	52.30	74.00	-21.70	PK	PASS
	H	2390.00	44.44	30.22	4.85	23.98	43.05	54.00	-10.95	AV	PASS
	H	2400.00	54.56	30.22	4.85	23.98	53.17	74.00	-20.83	PK	PASS
	H	2400.00	44.06	30.22	4.85	23.98	42.67	54.00	-11.33	AV	PASS
	V	2390.00	53.24	30.22	4.85	23.98	51.85	74.00	-22.15	PK	PASS
	V	2390.00	44.39	30.22	4.85	23.98	43.00	54.00	-11.00	AV	PASS
	V	2400.00	54.72	30.22	4.85	23.98	53.33	74.00	-20.67	PK	PASS
	V	2400.00	44.86	30.22	4.85	23.98	43.47	54.00	-10.53	AV	PASS
	High Channel 2462MHz										
	H	2483.50	53.84	30.22	4.85	23.98	52.45	74.00	-21.55	PK	PASS
	H	2483.50	44.41	30.22	4.85	23.98	43.02	54.00	-10.98	AV	PASS
	H	2500.00	54.31	30.22	4.85	23.98	52.92	74.00	-21.08	PK	PASS
	H	2500.00	44.68	30.22	4.85	23.98	43.29	54.00	-10.71	AV	PASS
	V	2483.50	54.75	30.22	4.85	23.98	53.36	74.00	-20.64	PK	PASS
	V	2483.50	44.67	30.22	4.85	23.98	43.28	54.00	-10.72	AV	PASS
V	2500.00	53.33	30.22	4.85	23.98	51.94	74.00	-22.06	PK	PASS	
V	2500.00	44.26	30.22	4.85	23.98	42.87	54.00	-11.13	AV	PASS	
802.11g	Low Channel 2412MHz										
	H	2390.00	53.88	30.22	4.85	23.98	52.49	74.00	-21.51	PK	PASS
	H	2390.00	44.76	30.22	4.85	23.98	43.37	54.00	-10.63	AV	PASS
	H	2400.00	53.78	30.22	4.85	23.98	52.39	74.00	-21.61	PK	PASS
	H	2400.00	44.93	30.22	4.85	23.98	43.54	54.00	-10.46	AV	PASS
	V	2390.00	54.90	30.22	4.85	23.98	53.51	74.00	-20.49	PK	PASS
	V	2390.00	44.72	30.22	4.85	23.98	43.33	54.00	-10.67	AV	PASS
	V	2400.00	54.30	30.22	4.85	23.98	52.91	74.00	-21.09	PK	PASS
	V	2400.00	44.43	30.22	4.85	23.98	43.04	54.00	-10.96	AV	PASS
	High Channel 2462MHz										
	H	2483.50	54.60	30.22	4.85	23.98	53.21	74.00	-20.79	PK	PASS
	H	2483.50	44.55	30.22	4.85	23.98	43.16	54.00	-10.84	AV	PASS
	H	2500.00	53.07	30.22	4.85	23.98	51.68	74.00	-22.32	PK	PASS
	H	2500.00	44.52	30.22	4.85	23.98	43.13	54.00	-10.87	AV	PASS
	V	2483.50	54.14	30.22	4.85	23.98	52.75	74.00	-21.25	PK	PASS
	V	2483.50	44.68	30.22	4.85	23.98	43.29	54.00	-10.71	AV	PASS
V	2500.00	54.99	30.22	4.85	23.98	53.60	74.00	-20.40	PK	PASS	
V	2500.00	44.70	30.22	4.85	23.98	43.31	54.00	-10.69	AV	PASS	
Remark:											
Emission Level = Meter Reading + Antenna Factor + Cable Loss – Pre-amplifier, Margin= Emission Level - Limit											



	Polar (H/V)	Frequency (MHz)	Meter Reading (dBuV)	Pre-amplifier (dB)	Cable Loss (dB)	Antenna Factor (dB/m)	Emission level (dBuV/m)	Limit (dBuV/m)	Margin (dB)	Detector Type	Result
802.11 n20	Low Channel 2412MHz										
	H	2390.00	53.68	30.22	4.85	23.98	52.29	74.00	-21.71	PK	PASS
	H	2390.00	44.16	30.22	4.85	23.98	42.77	54.00	-11.23	AV	PASS
	H	2400.00	54.86	30.22	4.85	23.98	53.47	74.00	-20.53	PK	PASS
	H	2400.00	44.47	30.22	4.85	23.98	43.08	54.00	-10.92	AV	PASS
	V	2390.00	54.61	30.22	4.85	23.98	53.22	74.00	-20.78	PK	PASS
	V	2390.00	44.75	30.22	4.85	23.98	43.36	54.00	-10.64	AV	PASS
	V	2400.00	54.84	30.22	4.85	23.98	53.45	74.00	-20.55	PK	PASS
	V	2400.00	44.05	30.22	4.85	23.98	42.66	54.00	-11.34	AV	PASS
	High Channel 2462MHz										
	H	2483.50	53.74	30.22	4.85	23.98	52.35	74.00	-21.65	PK	PASS
	H	2483.50	44.21	30.22	4.85	23.98	42.82	54.00	-11.18	AV	PASS
	H	2500.00	53.66	30.22	4.85	23.98	52.27	74.00	-21.73	PK	PASS
	H	2500.00	44.76	30.22	4.85	23.98	43.37	54.00	-10.63	AV	PASS
	V	2483.50	54.98	30.22	4.85	23.98	53.59	74.00	-20.41	PK	PASS
	V	2483.50	44.68	30.22	4.85	23.98	43.29	54.00	-10.71	AV	PASS
V	2500.00	54.64	30.22	4.85	23.98	53.25	74.00	-20.75	PK	PASS	
V	2500.00	44.15	30.22	4.85	23.98	42.76	54.00	-11.24	AV	PASS	

Remark:

Emission Level = Meter Reading + Antenna Factor + Cable Loss – Pre-amplifier, Margin= Emission Level - Limit



6. POWER SPECTRAL DENSITY TEST

Test Requirement:	FCC Part15 C Section 15.247 (e)
Test Method:	KDB558074 D0115.247 Meas Guidancev05r02

6.1 APPLIED PROCEDURES / LIMIT

FCC Part15 (15.247) , Subpart C				
Section	Test Item	Limit	Frequency Range (MHz)	Result
15.247	Power Spectral Density	8dBm/3kHz	2400-2483.5	PASS

6.2 TEST PROCEDURE

1. Set analyzer center frequency to DTS channel center frequency.
2. Set the span to 1.5 times the DTS bandwidth.
3. Set the RBW to: $3 \text{ kHz} \leq \text{RBW} \leq 100 \text{ kHz}$.
4. Set the VBW $\geq 3 \times \text{RBW}$.
5. Detector = peak.
6. Sweep time = auto couple.
7. Trace mode = max hold.
8. Allow trace to fully stabilize.
9. Use the peak marker function to determine the maximum amplitude level within the RBW.
10. If measured value exceeds limit, reduce RBW (no less than 3 kHz) and repeat.

6.3 DEVIATION FROM STANDARD

No deviation.

6.4 TEST SETUP



6.5 EUT OPERATION CONDITIONS

The EUT tested system was configured as the statements of 2.1 Unless otherwise a special operating condition is specified in the follows during the testing.



6.6 TEST RESULT

Temperature :	26°C	Relative Humidity :	54%
Pressure :	101kPa	Test Voltage :	DC 3.7V

Test Mode	Frequency (MHz)	Power SpectralDensity (dBm/3kHz)	Limit (dBm/3kHz)	Result
802.11b	2412	-18.620	8	PASS
	2437	-17.944	8	PASS
	2462	-18.190	8	PASS
802.11g	2412	-21.895	8	PASS
	2437	-21.461	8	PASS
	2462	-22.762	8	PASS
802.11n20	2412	-22.954	8	PASS
	2437	-21.747	8	PASS
	2462	-22.643	8	PASS



802.11b -CH01

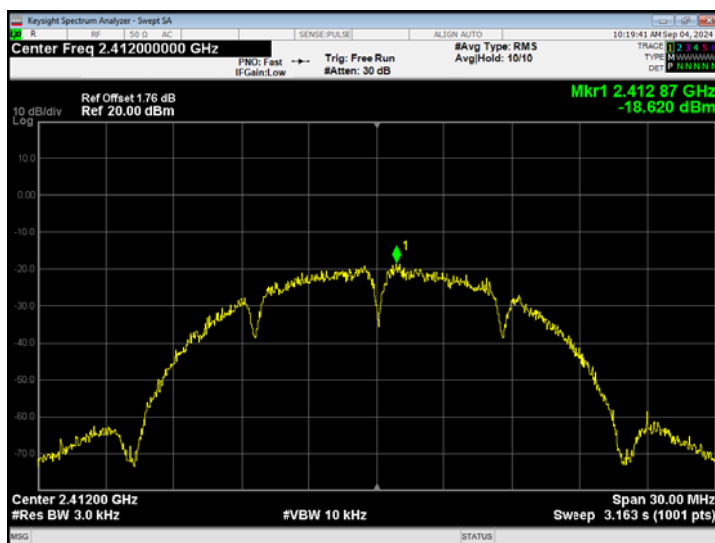

802.11b -CH06

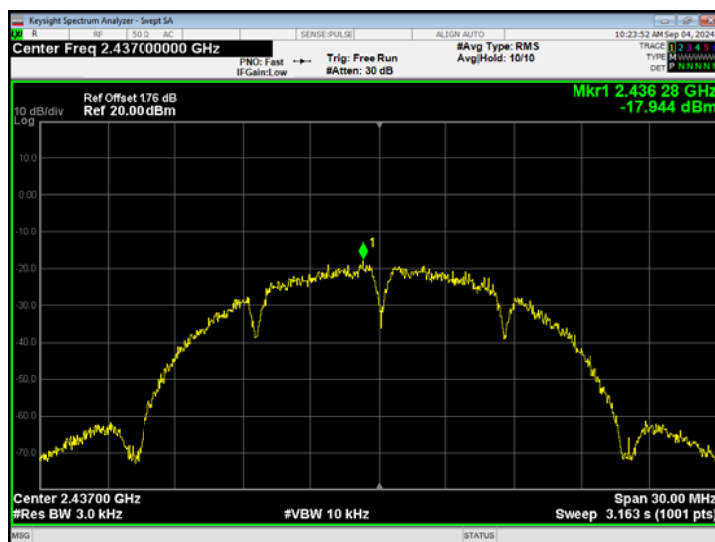

802.11b -CH11

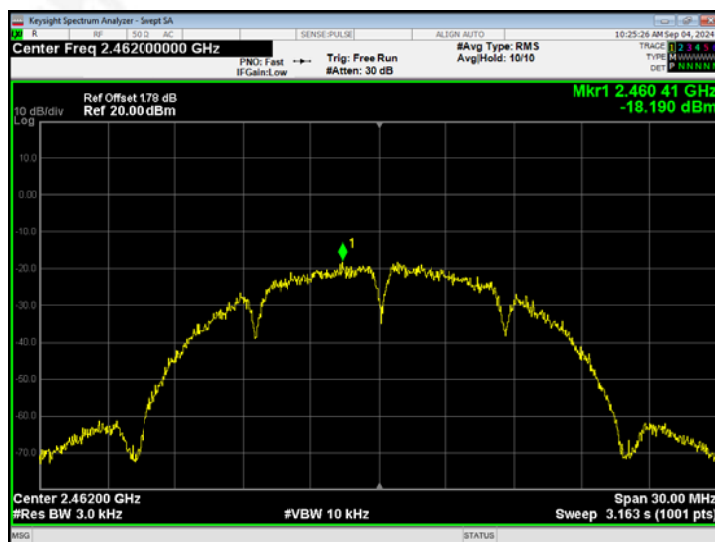



802.11g -CH01

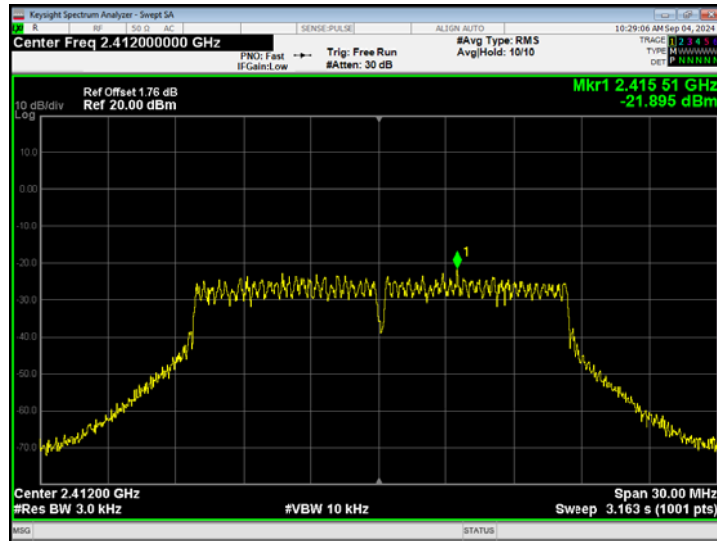

802.11g -CH06

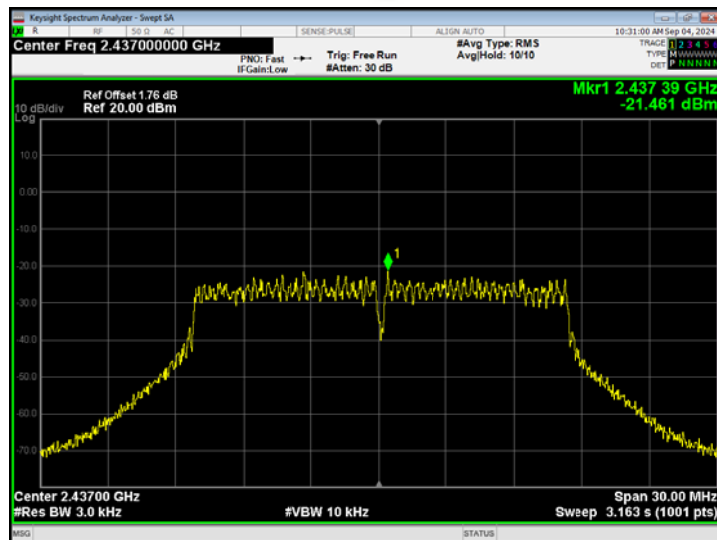

802.11g -CH11

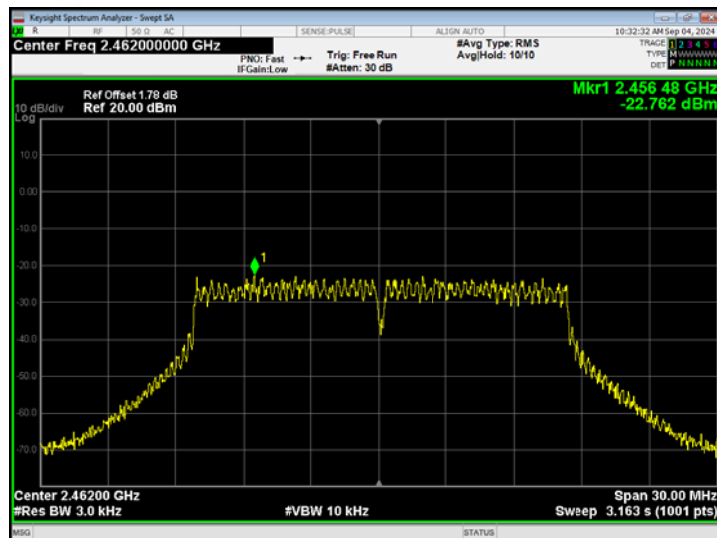



802.11n20 -CH01

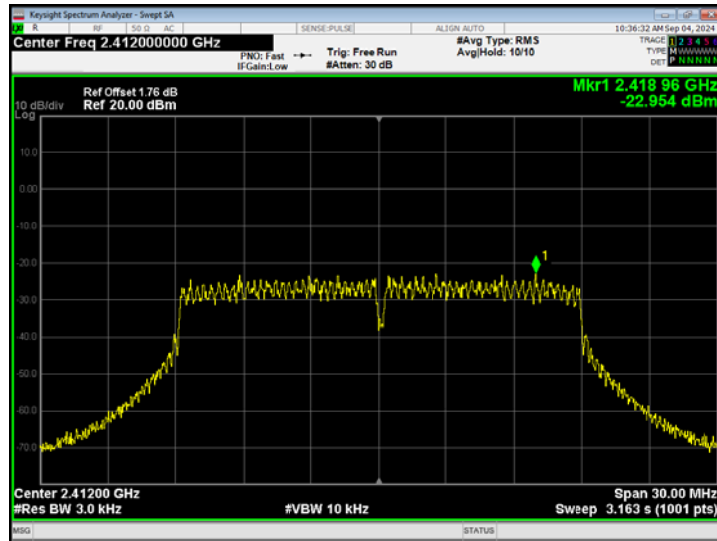

802.11n20 -CH06

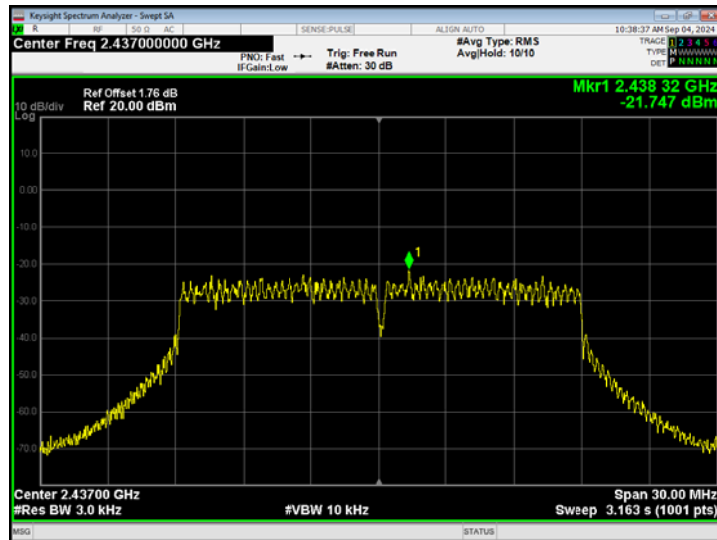

802.11n20 -CH11

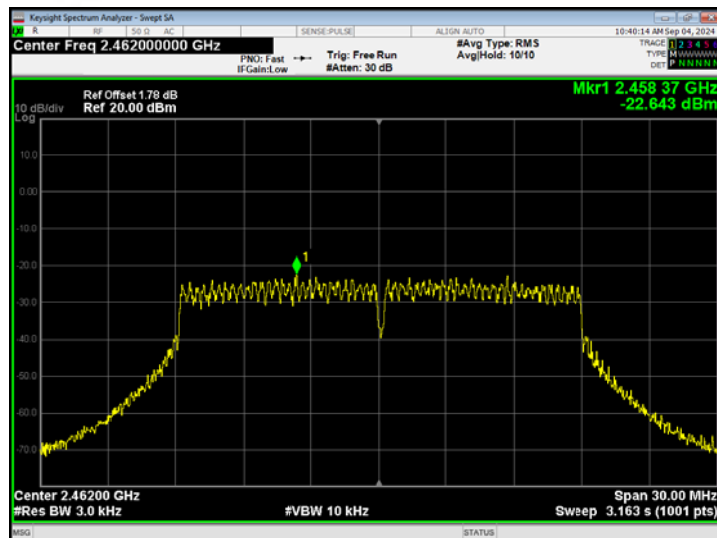



7. 6DB OCCUPIED BANDWIDTH

Test Requirement:	FCC Part15 C Section 15.247 (a)(2)
Test Method:	KDB558074 D0115.247 Meas Guidancev05r02

7.1 APPLIED PROCEDURES / LIMIT

FCC Part15 (15.247) , Subpart C				
Section	Test Item	Limit	Frequency Range (MHz)	Result
15.247(a)(2)	Bandwidth	$\geq 500\text{KHz}$ (6dB Occupied Bandwidth)	2400-2483.5	PASS

7.2 TEST PROCEDURE

1. Set RBW = 100 kHz.
2. Set the video bandwidth (VBW) $\geq 3 \times \text{RBW}$.
3. Detector = Peak.
4. Trace mode = max hold.
5. Sweep = auto couple.
6. Allow the trace to stabilize.
7. Measure the maximum width of the emission that is constrained by the frequencies associated with the two outermost amplitude points (upper and lower frequencies) that are attenuated by 6 dB relative to the maximum level measured in the fundamental emission.

7.3 DEVIATION FROM STANDARD

No deviation.

7.4 TEST SETUP

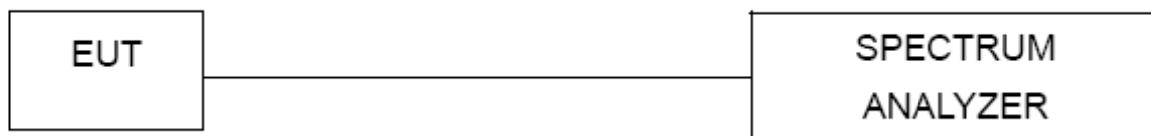

7.5 EUT OPERATION CONDITIONS

The EUT tested system was configured as the statements of 2.4 Unless otherwise a special operating condition is specified in the follows during the testing.



7.6 TEST RESULT

Temperature :	26°C	Relative Humidity :	54%
Pressure :	101kPa	Test Voltage :	DC 3.7V
Test Mode :	TX		

Test Mode	Test Channel (MHz)	6dB Occupied Bandwidth (MHz)	Limit (kHz)	Result
802.11b	2412	9.043	>500	Pass
	2437	9.554		
	2462	10.044		
802.11g	2412	16.317	>500	Pass
	2437	16.316		
	2462	16.300		
802.11n20	2412	17.042	>500	Pass
	2437	16.655		
	2462	17.531		



802.11b -CH01

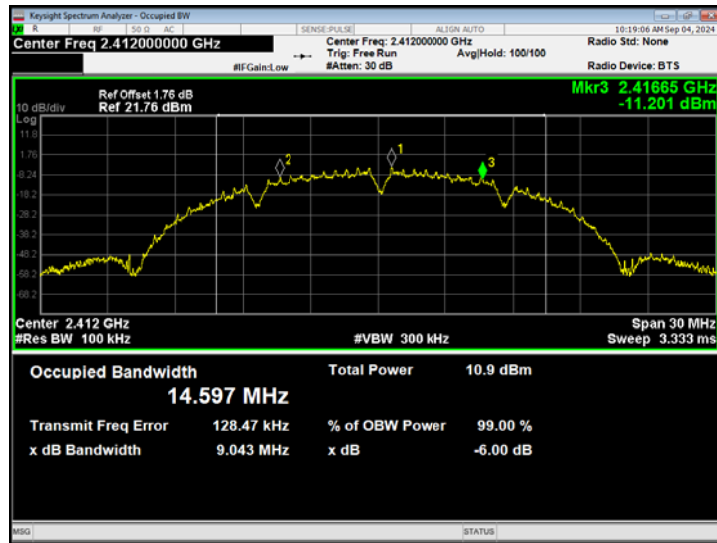

802.11b -CH06

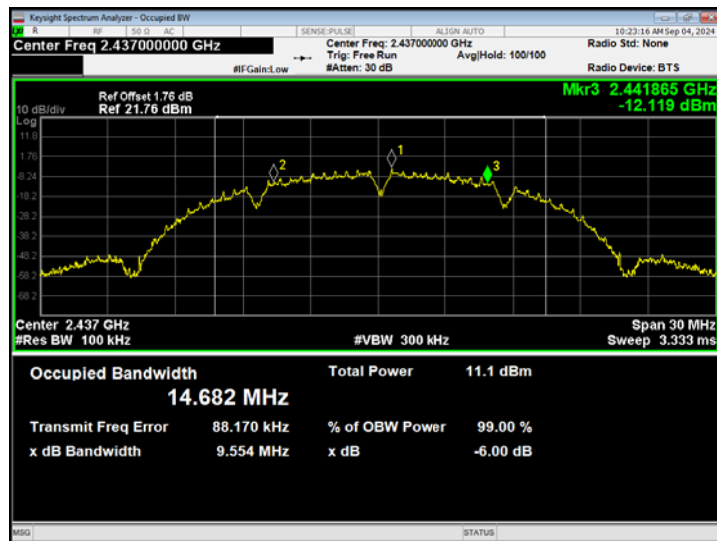

802.11b -CH11

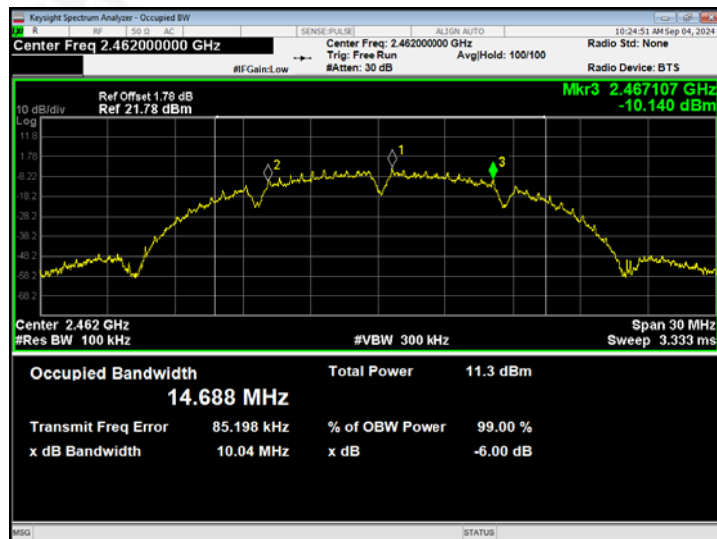



802.11g -CH01

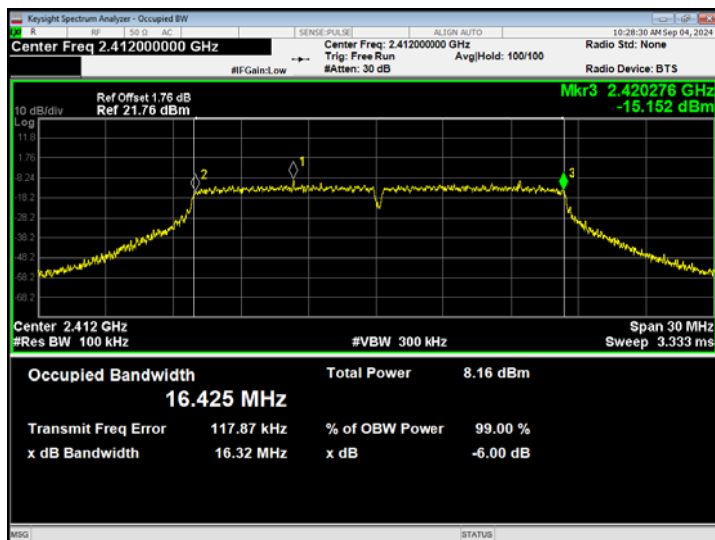

802.11g -CH06

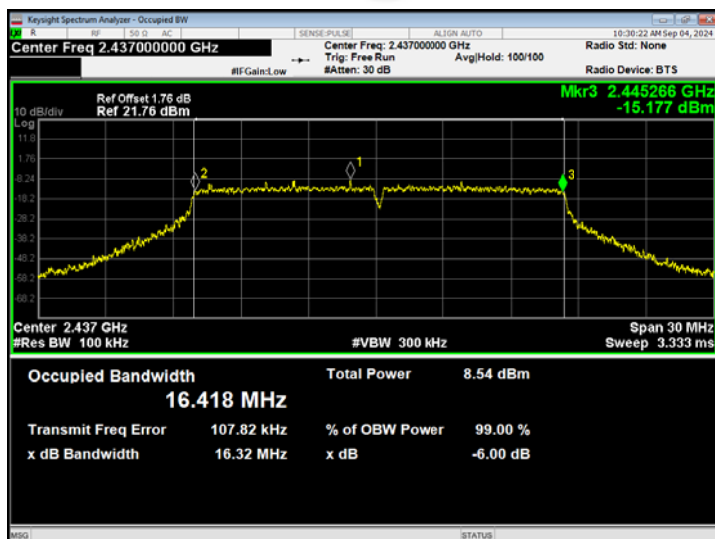

802.11g -CH11

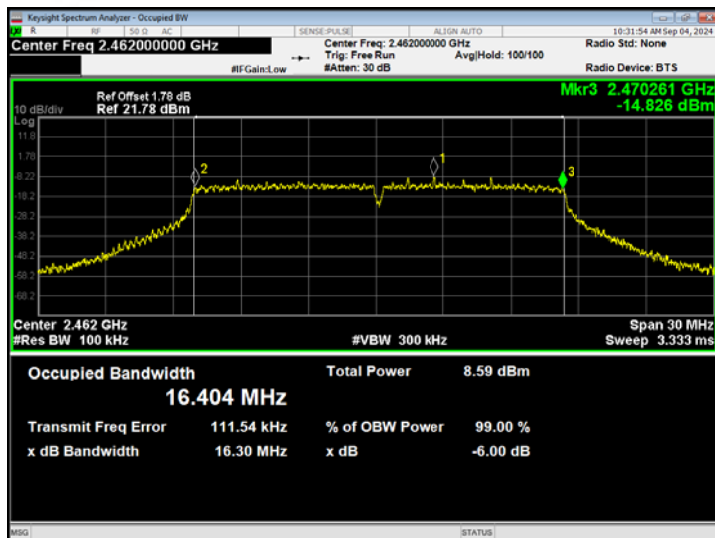



802.11n20 -CH01

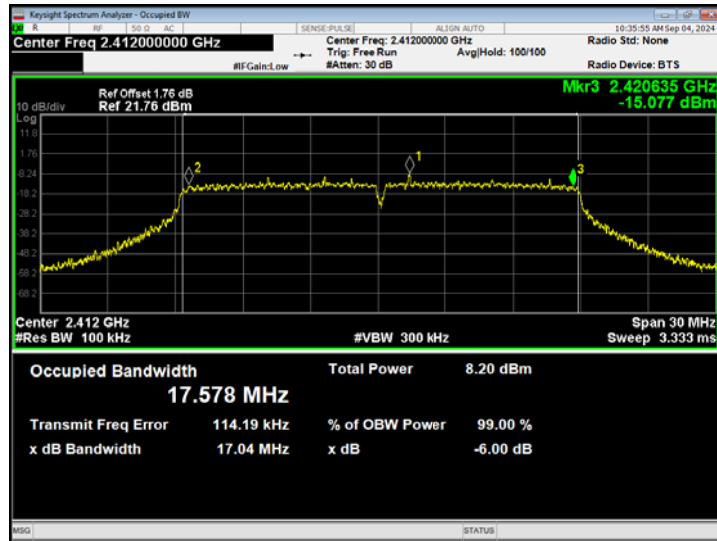

802.11n20 -CH06

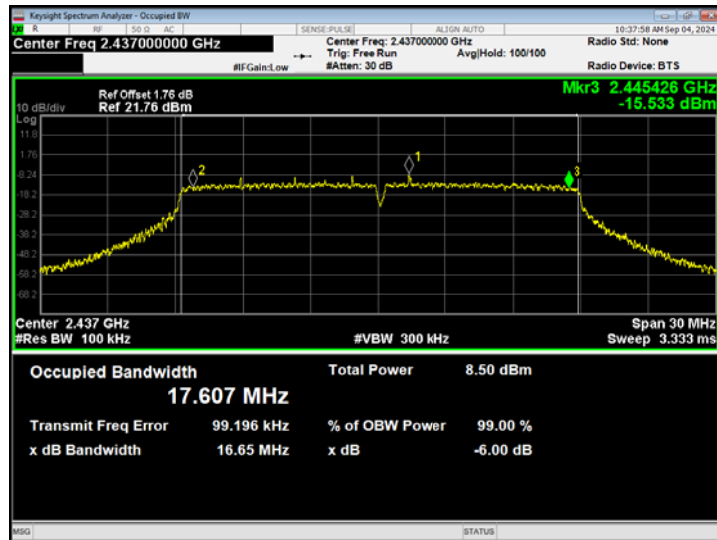

802.11n20 -CH11

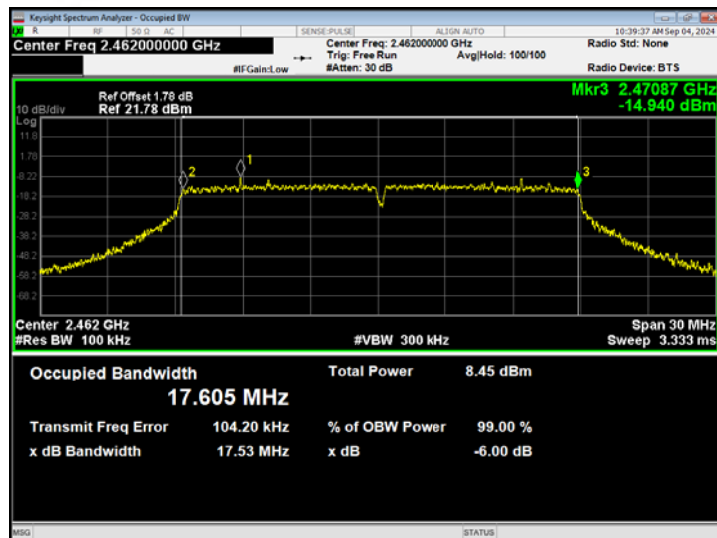



8. PEAK OUTPUT POWER TEST

Test Requirement:	FCC Part15 C Section 15.247 (b)(3)
Test Method:	KDB558074 D0115.247 Meas Guidancev05r02

8.1 APPLIED PROCEDURES/LIMIT

FCC Part15 (15.247) , Subpart C				
Section	Test Item	Limit	Frequency Range (MHz)	Result
15.247(b)(3)	Peak Output Power	1 watt or 30dBm	2400-2483.5	PASS

8.2 TEST PROCEDURE

- a. The EUT was directly connected to the Power meter

8.3 DEVIATION FROM STANDARD

No deviation.

8.4 TEST SETUP



8.5 EUT OPERATION CONDITIONS

The EUT tested system was configured as the statements of 2.4 Unless otherwise a special operating condition is specified in the follows during the testing.



8.6 TEST RESULT

Temperature :	26°C	Relative Humidity :	54%
Pressure :	101kPa	Test Voltage :	DC 3.7V

Test Mode	Test Channel (MHz)	Peak Output Power (dBm)	Limit (dBm)	Result
802.11b	2412	8.649	30.00	Pass
	2437	8.505		
	2462	8.509		
802.11g	2412	7.443	30.00	Pass
	2437	7.625		
	2462	7.781		
802.11n20	2412	7.624	30.00	Pass
	2437	7.456		
	2462	7.315		



9. CONDUCTED BAND EDGE AND SPURIOUS EMISSION

Test Requirement:	FCC Part15 C Section 15.247 (d)
Test Method:	KDB558074 D0115.247 Meas Guidancev05r02

9.1 APPLICABLE STANDARD

in any 100 kHz bandwidth outside the frequency bands in which the spread spectrum intentional radiator is operating, the radio frequency power that is produced by the intentional radiator shall be at least 20dB below that in the 100kHz bandwidth within the band that contains the highest level of the desired power, In addition, radiated emissions which fall in the restricted bands, as defined in§15.205(a), must also comply with the radiated emission limits specified in15.209(a).

9.2 TEST PROCEDURE

Using the following spectrum analyzer setting:

- A) Set the RBW = 100KHz.
- B) Set the VBW = 300KHz.
- C) Sweep time = auto couple.
- D) Detector function = peak.
- E) Trace mode = max hold.
- F) Allow trace to fully stabilize.

9.3 DEVIATION FROM STANDARD

No deviation.

9.4 TEST SETUP



9.5 EUT OPERATION CONDITIONS

The EUT tested system was configured as the statements of 2.4 Unless otherwise a special operating condition is specified in the follows during the testing.

9.6 TEST RESULTS



Band edge test plot as follows:

Temperature :	26°C	Relative Humidity :	54%
Pressure :	101kPa	Test Voltage :	DC 3.7V

802.11b - Lowest channel

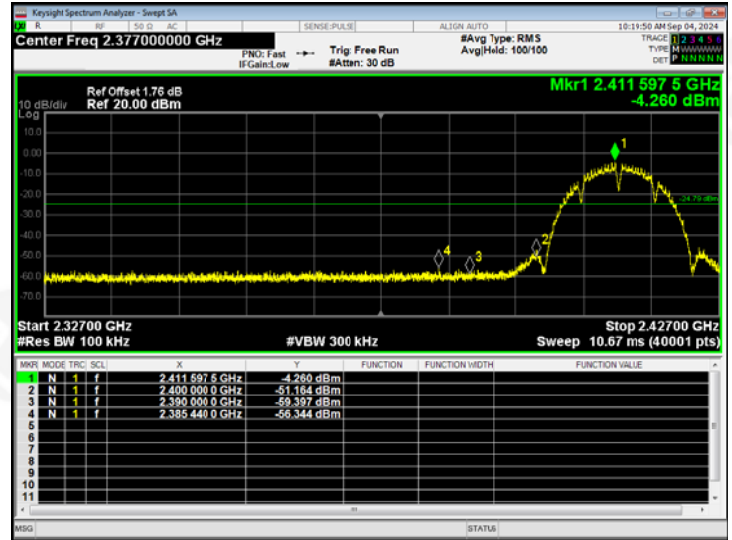
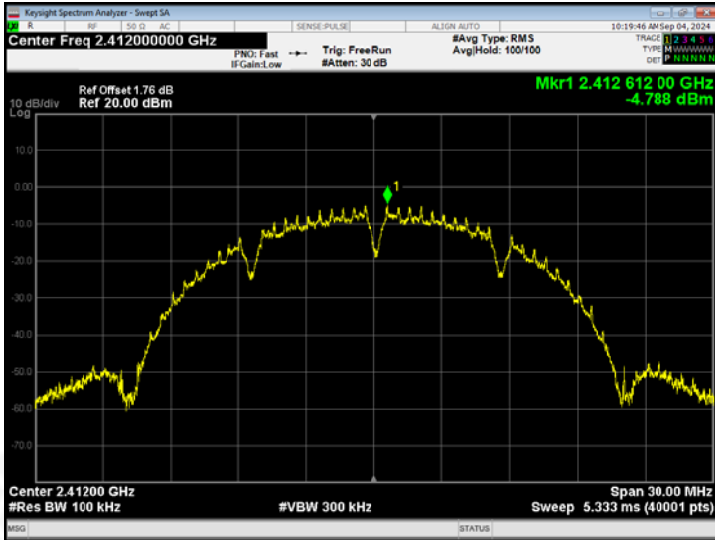

802.11b - Highest channel

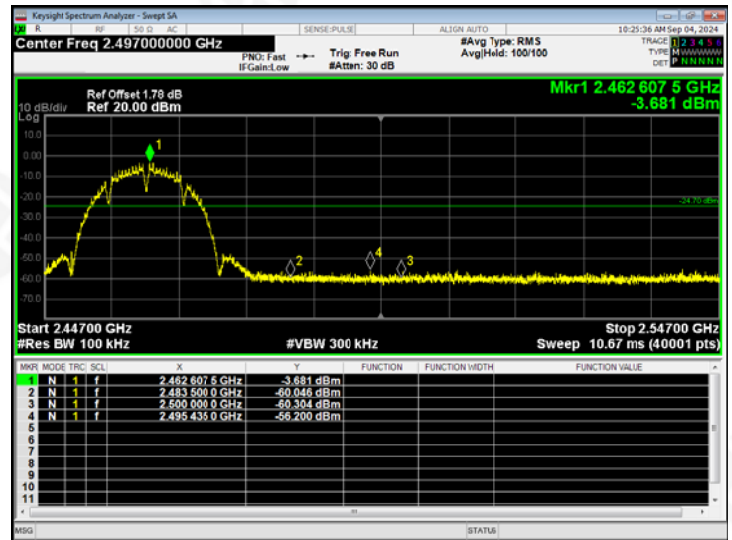
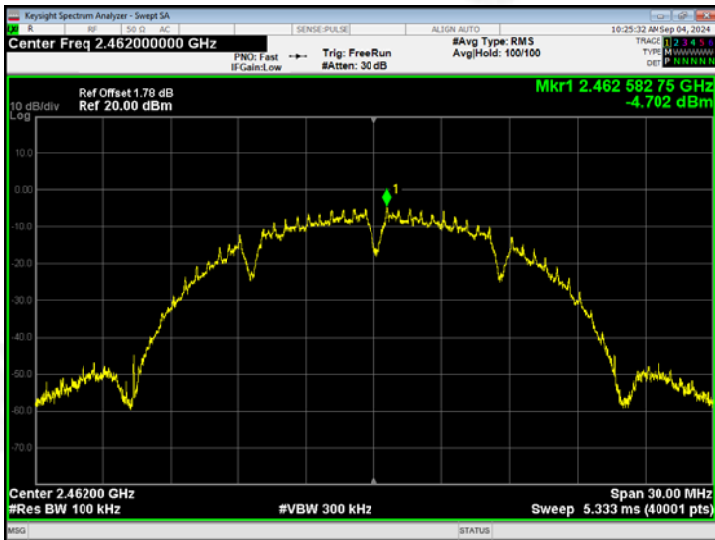



802.11g - Lowest channel

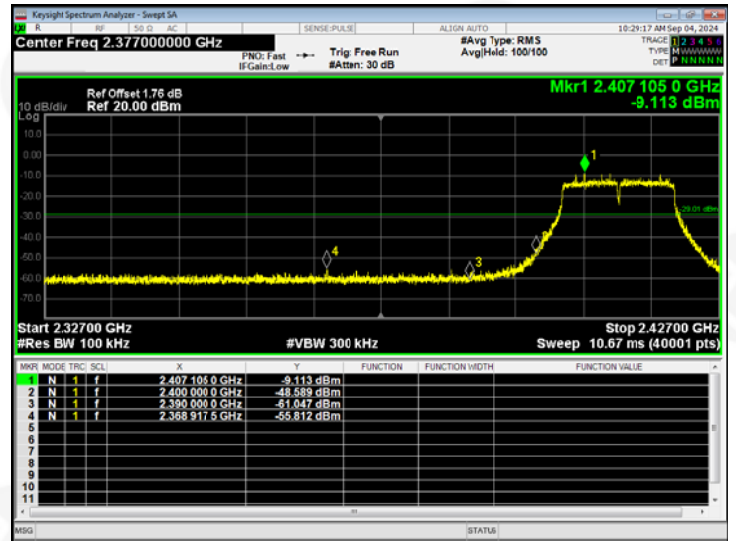
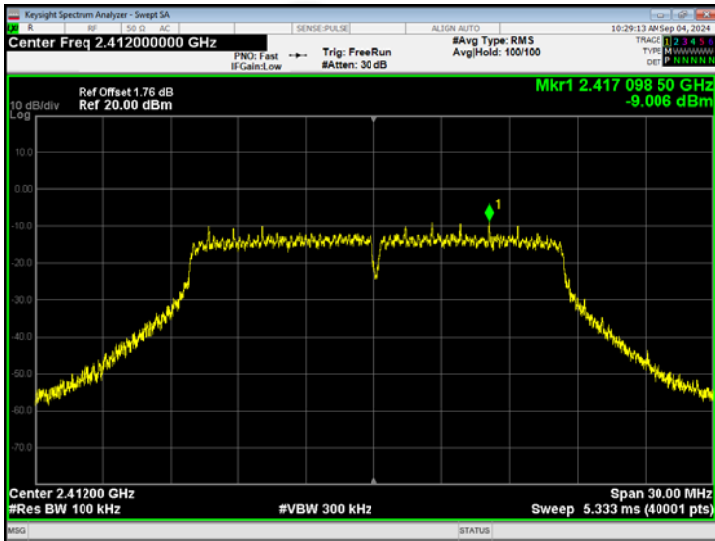

802.11g - Highest channel

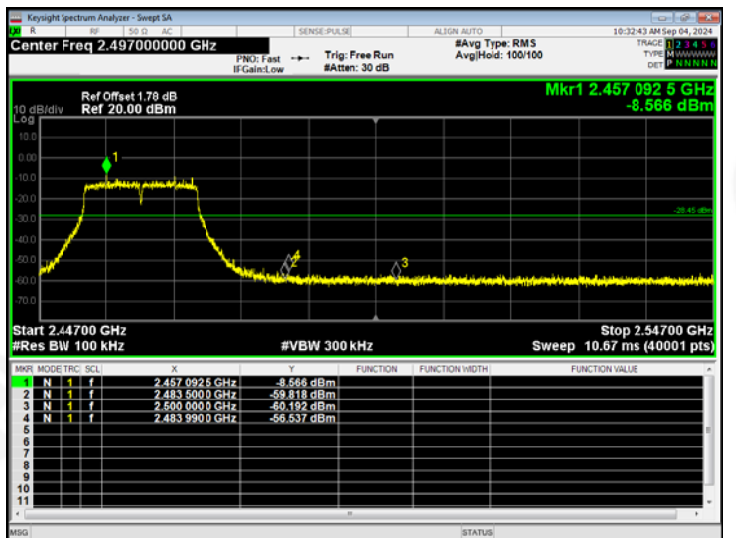
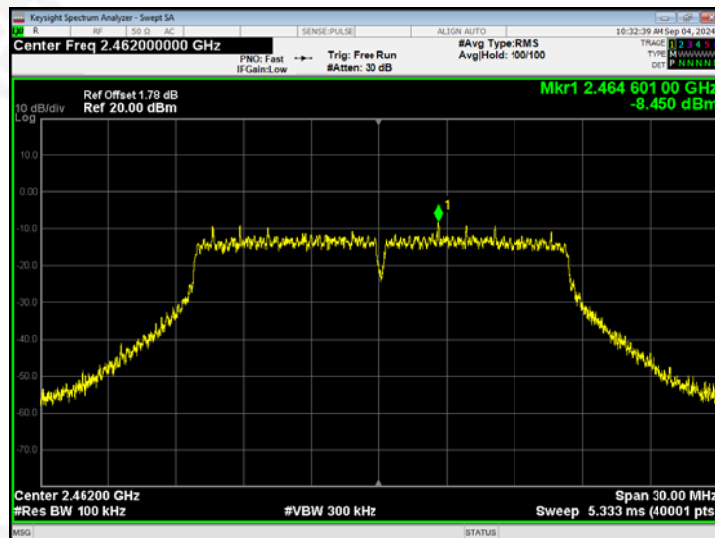



802.11n20 - Lowest channel

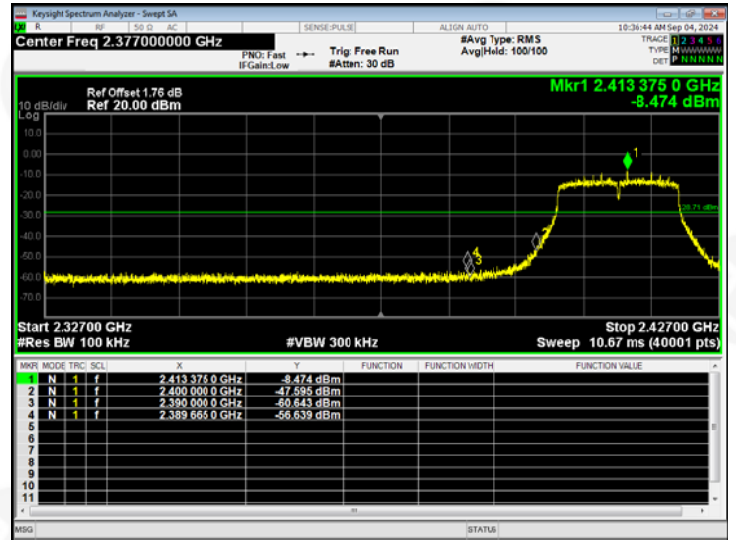
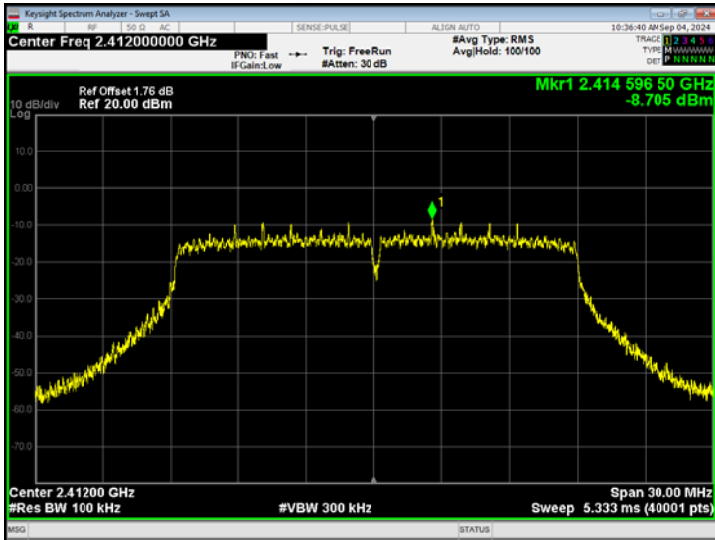

802.11n20 - Highest channel

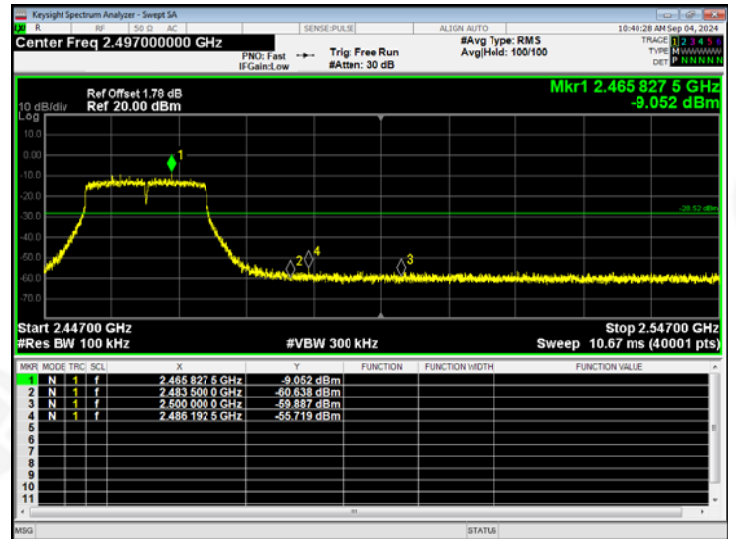
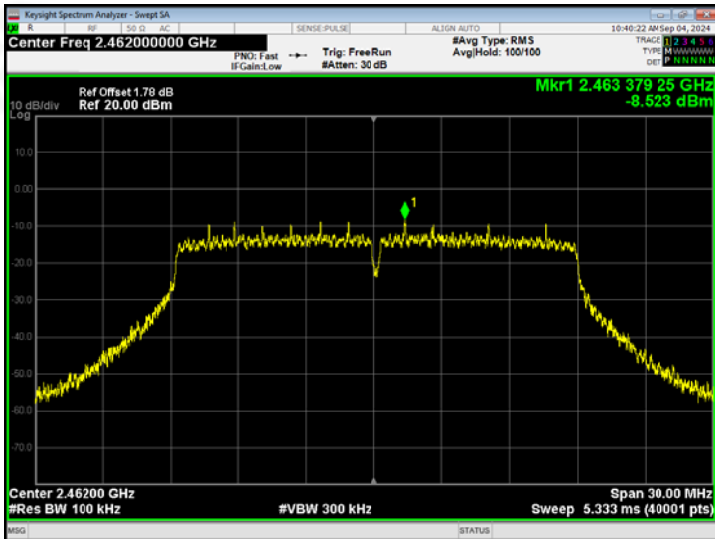



Spurious emission test plot as follows:

Temperature :	26°C	Relative Humidity :	54%
Pressure :	101kPa	Test Voltage :	DC 3.7V

802.11b

Lowest channel

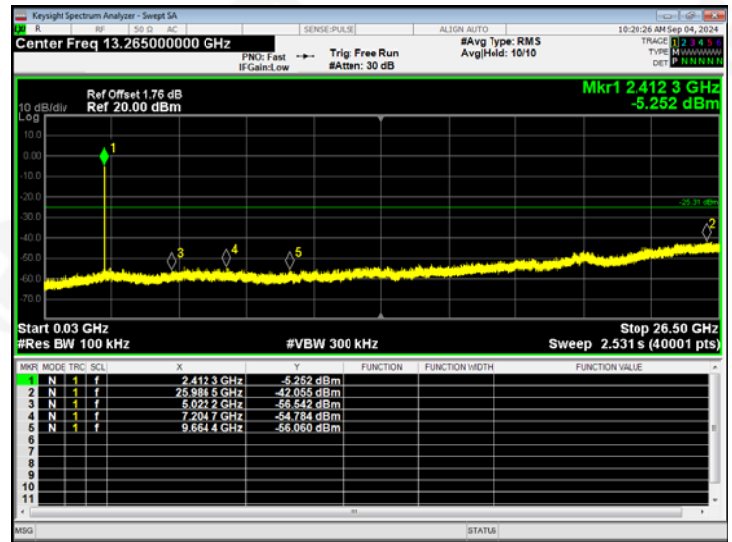
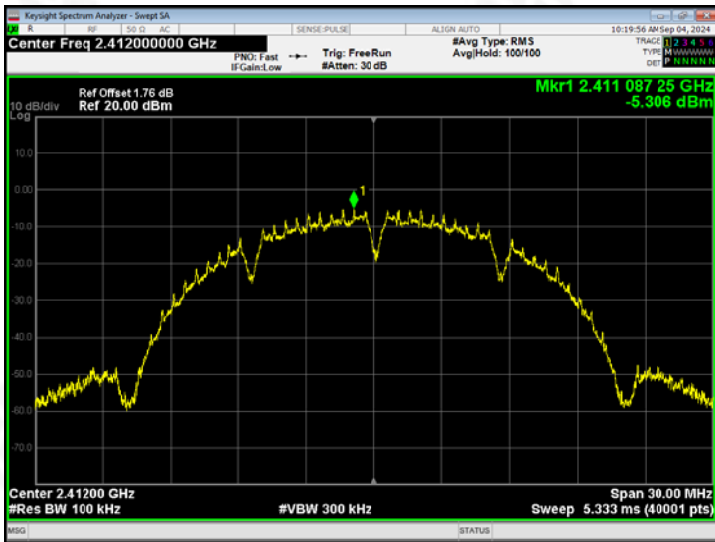

Middle channel

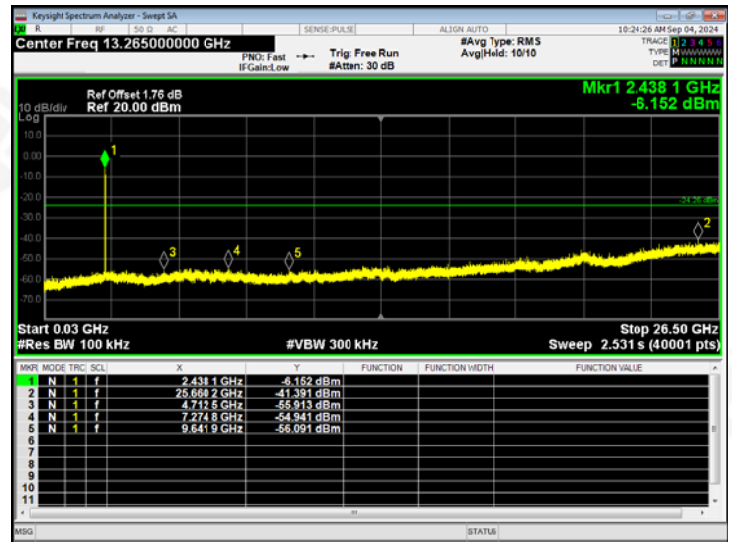
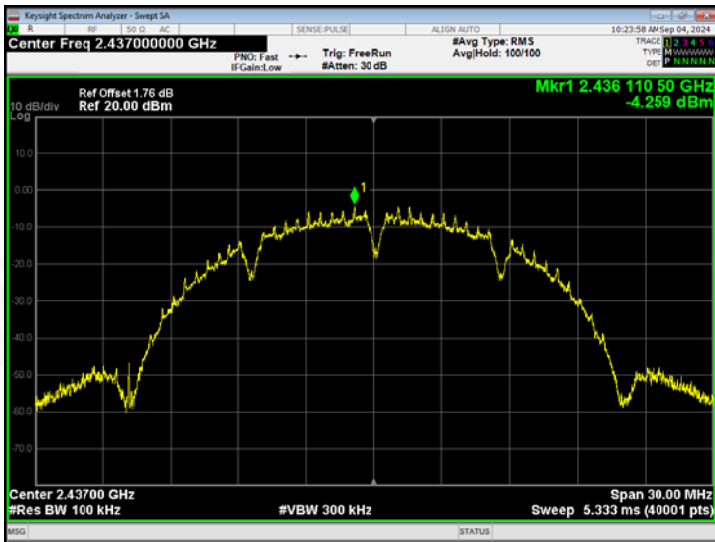



Highest channel

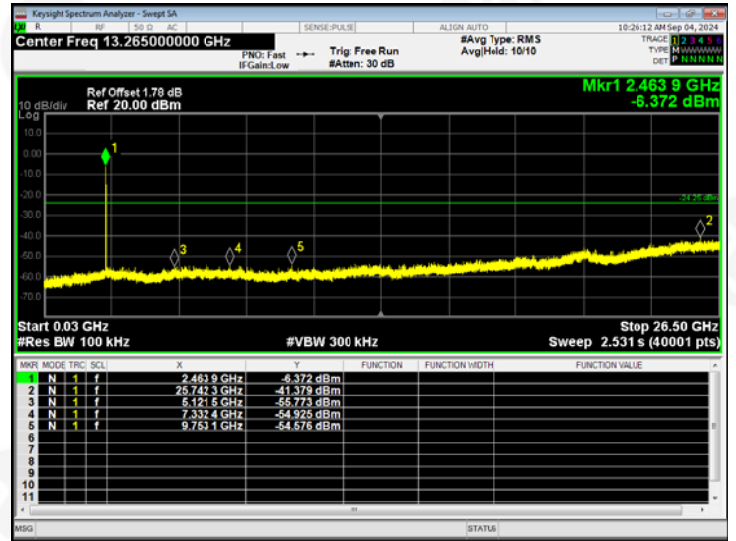
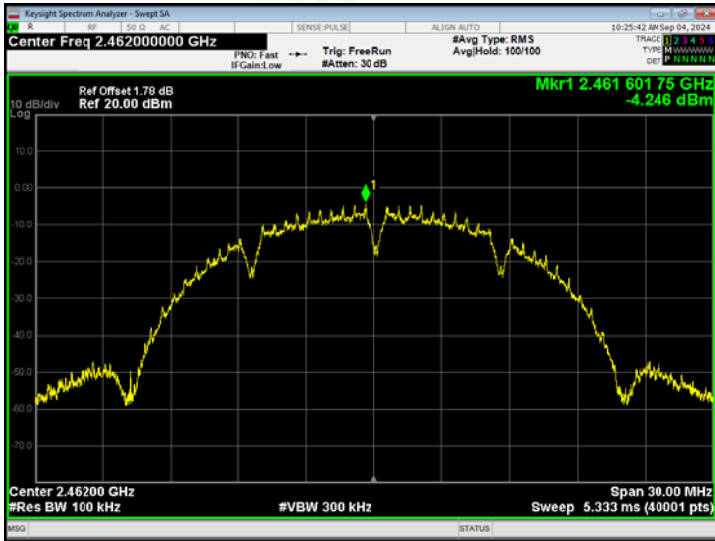

30MHz~26.5GHz



802.11g

Lowest channel

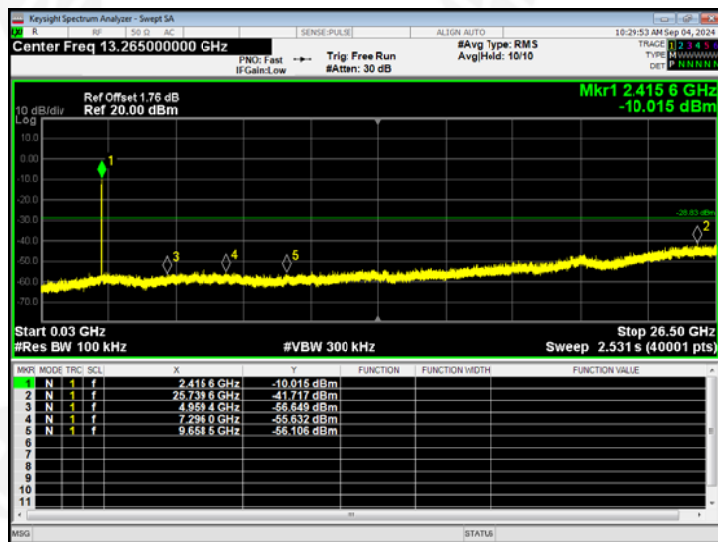
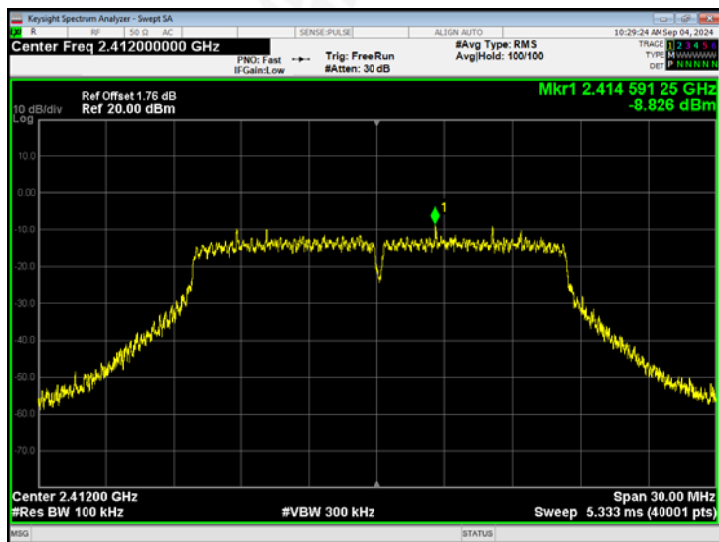

Middle channel

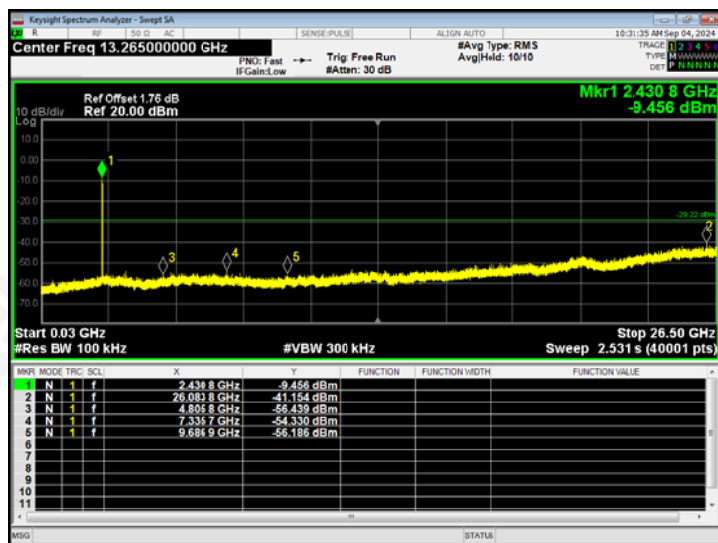
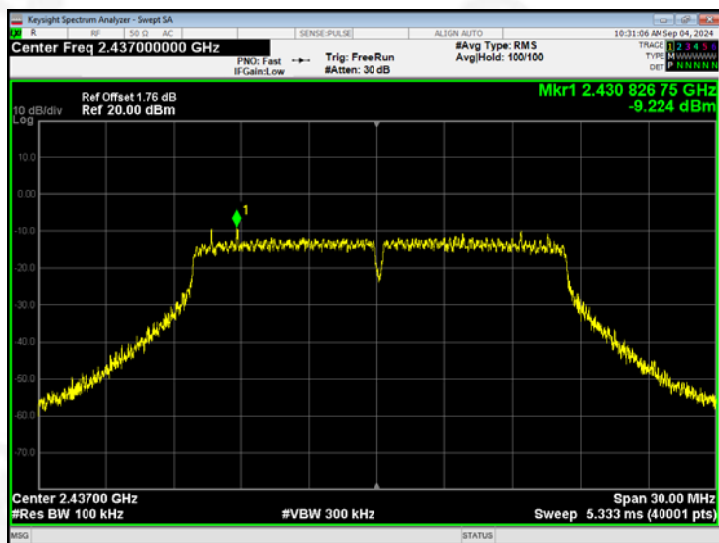



Highest channel

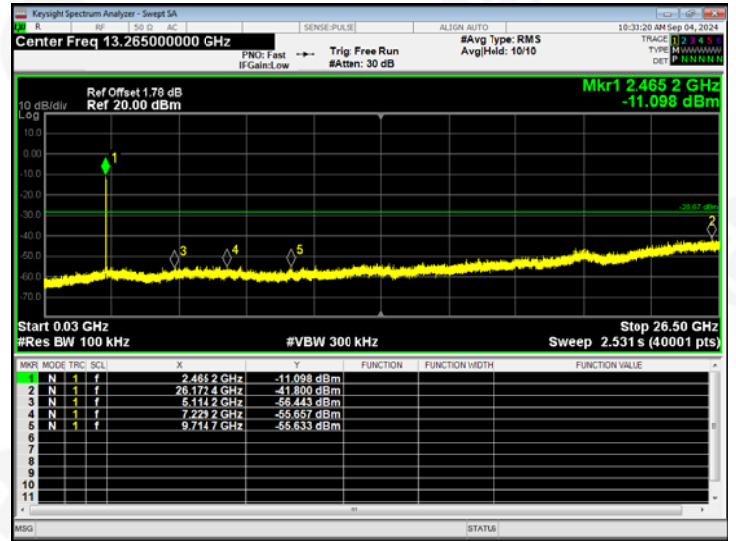
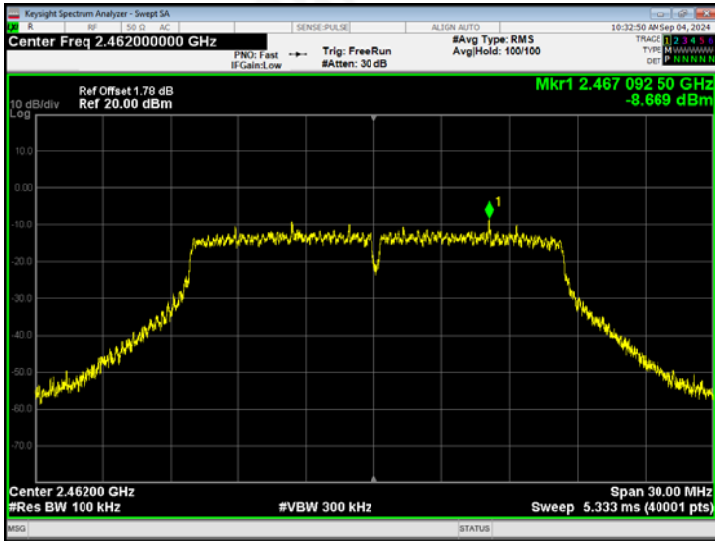

30MHz~26.5GHz



802.11n20

Lowest channel

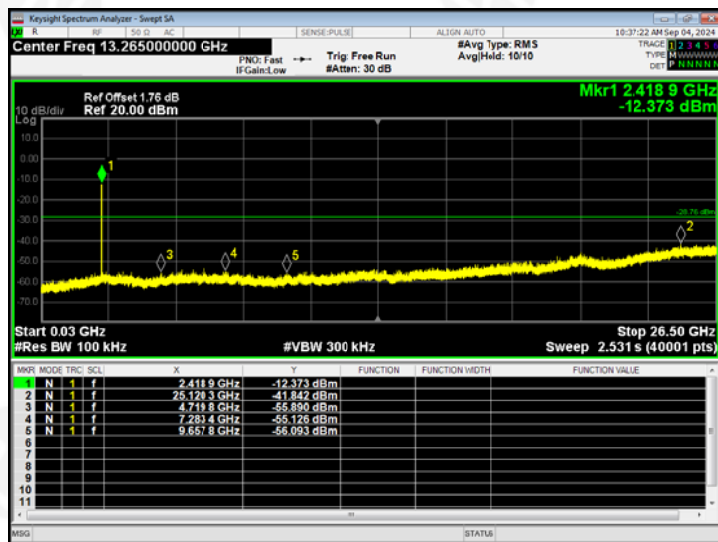
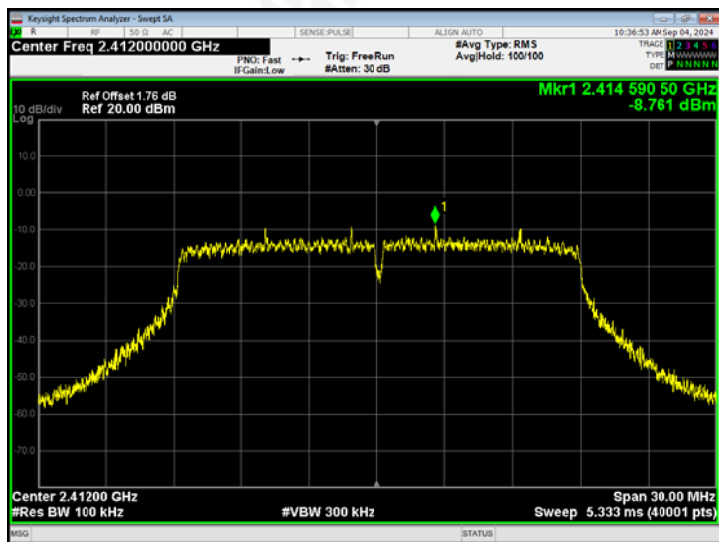

Middle channel

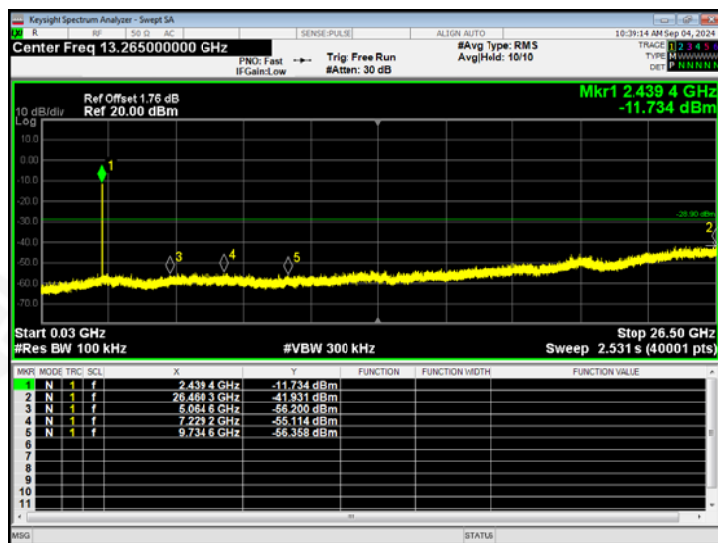
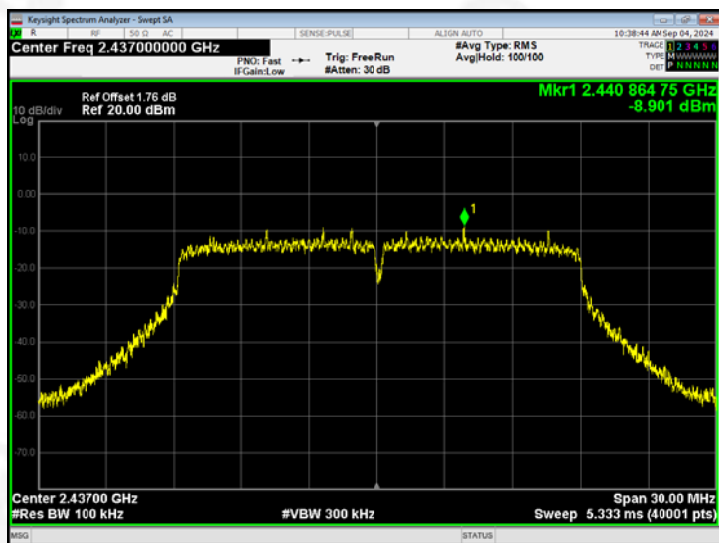



Highest channel

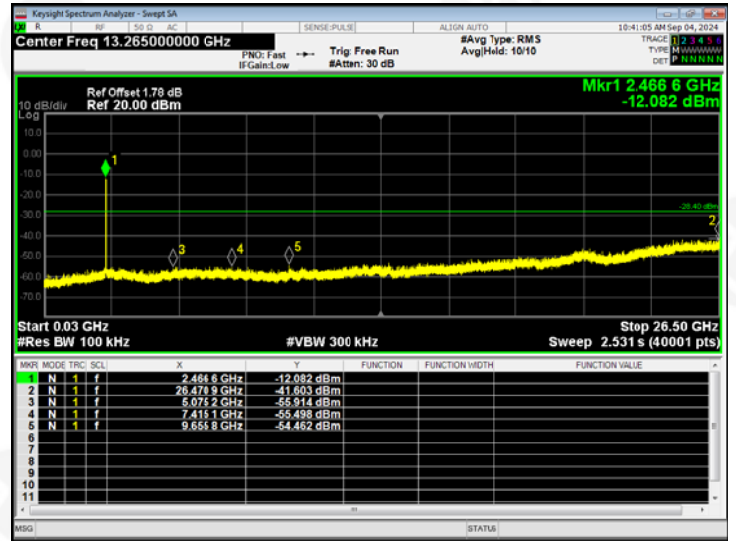
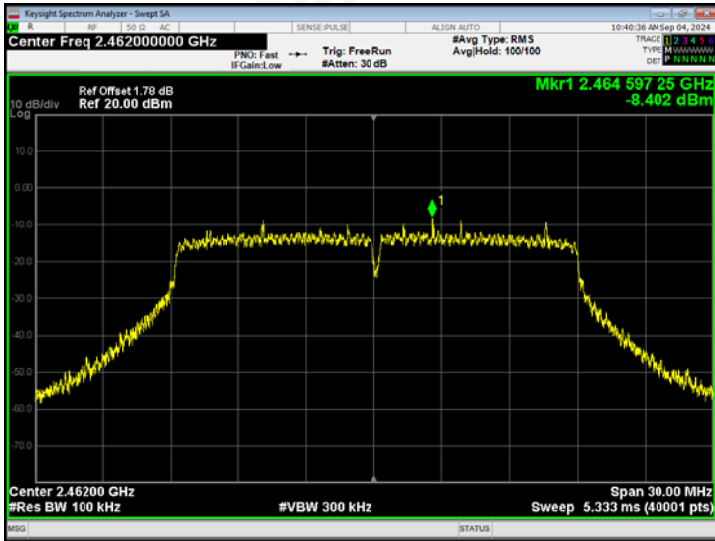

30MHz~26.5GHz



10. DUTY CYCLE

Test Method:	ANSI C63.10:2013
--------------	------------------

10.1 APPLIED PROCEDURES / LIMIT

Measurements of duty cycle and transmission duration shall be performed using one of the following techniques:

- a) A diode detector and an oscilloscope that together have a sufficiently short response time to permit accurate measurements of the ON and OFF times of the transmitted signal.
- b) The zero-span mode on a spectrum analyzer or EMI receiver if the response time and spacing between bins on the sweep are sufficient to permit accurate measurements of the ON and OFF times of the transmitted signal:
 - 1) Set the center frequency of the instrument to the center frequency of the transmission.
 - 2) Set $RBW \geq OBW$ if possible; otherwise, set RBW to the largest available value.
 - 3) Set $VBW \geq RBW$. Set detector = peak or average.
 - 4) The zero-span measurement method shall not be used unless both RBW and VBW are $> 50/T$ and the number of sweep points across duration T exceeds 100. (For example, if VBW and/or RBW are limited to 3 MHz, then the zero-span method of measuring the duty cycle shall not be used if $T \leq 16.7 \mu s$.)

10.2 DEVIATION FROM STANDARD

No deviation.

10.3 TEST SETUP

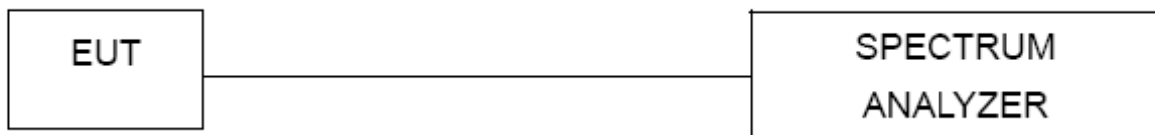



10.4 TEST RESULTS

Temperature :	26°C	Relative Humidity :	54%
Pressure :	101kPa	Test Voltage :	DC 3.7V

Test Mode	Test Frequency (MHz)	Duty Cycle (%)	Factor (dB)	Result
802.11b	2412	98.96	0.00	Pass
802.11g	2412	94.06	0.27	Pass
802.11n20	2412	93.66	0.28	Pass



802.11b

2412MHz

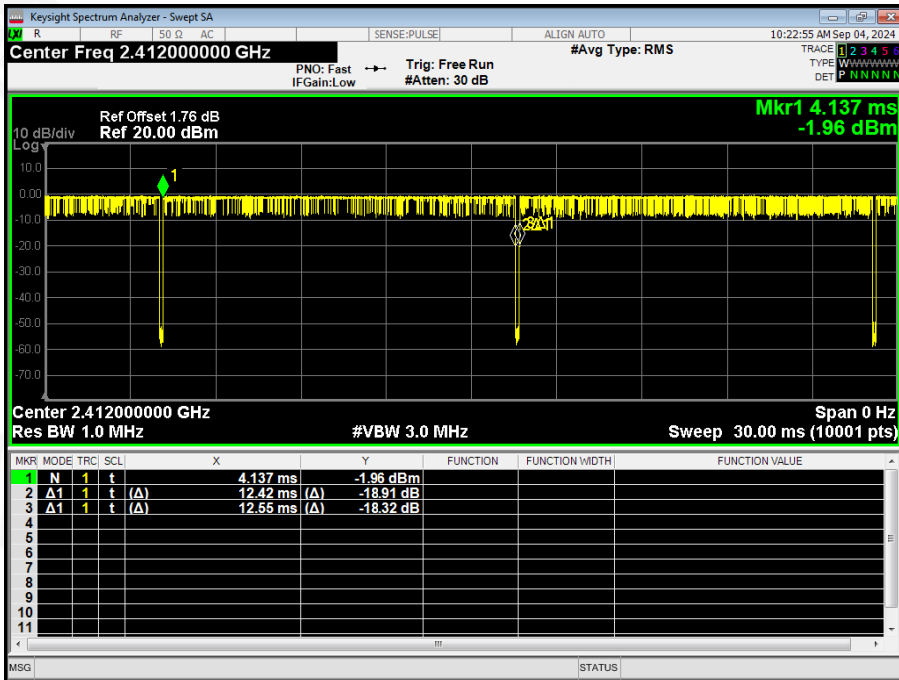

802.11g

2412MHz

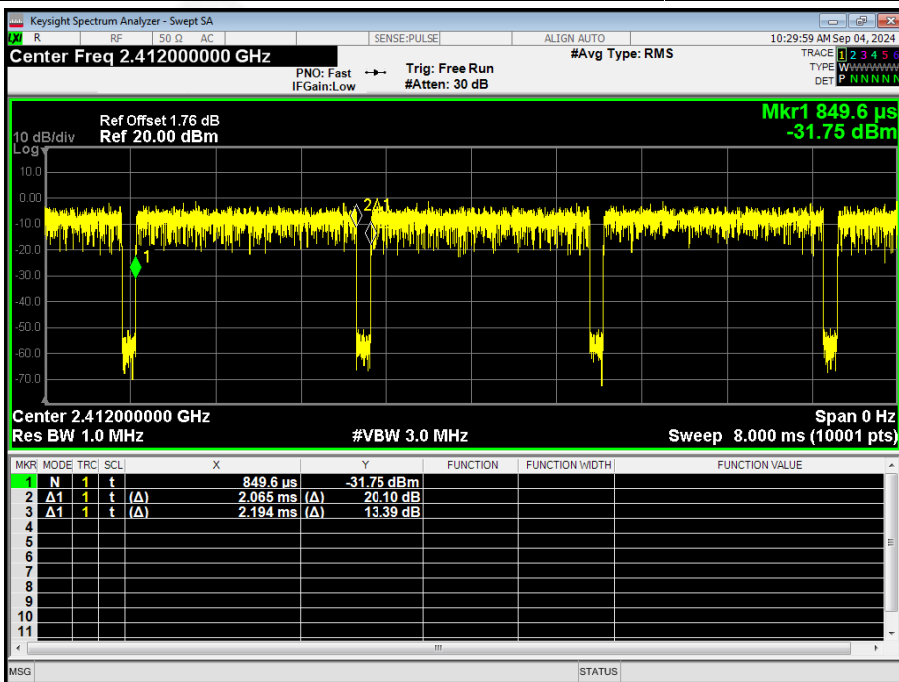

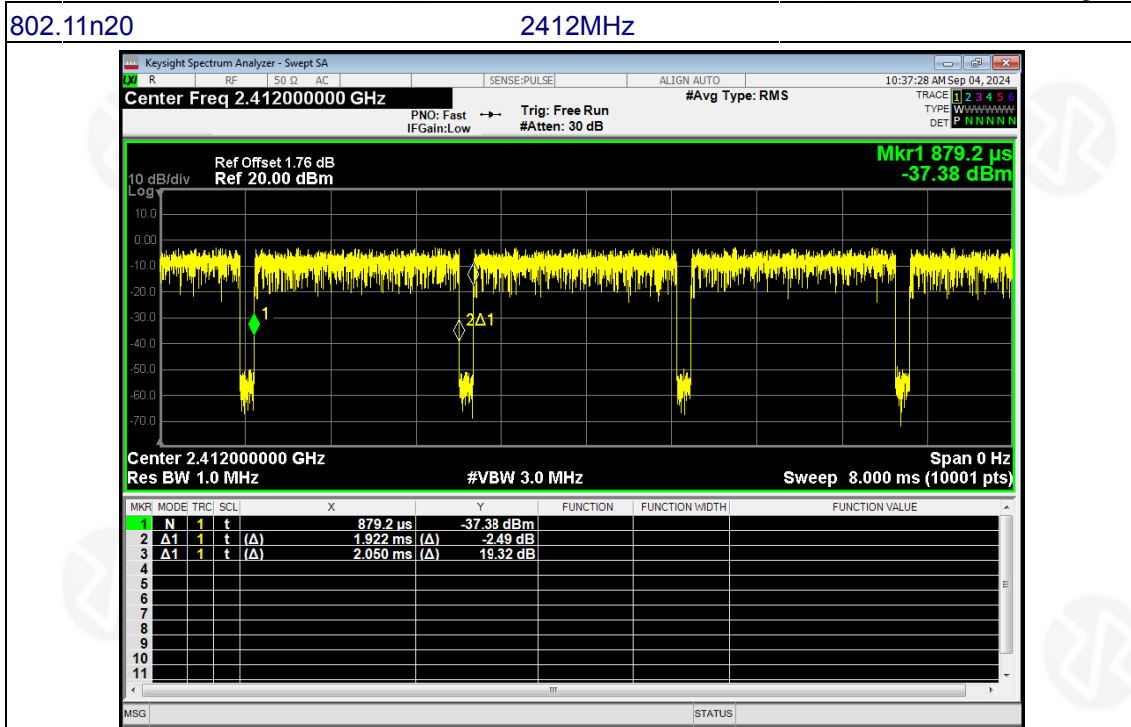

Note: All channel have been tested, and the report only reflects the worst case data.
 Duty Cycle= Ton /Total*100%;
 Duty Cycle Correction Factor= 10log (1/Duty Cycle).



11. ANTENNA REQUIREMENT

Standard requirement:	FCC Part15 C Section 15.203 /247(c)
15.203 requirement: An intentional radiator shall be designed to ensure that no antenna other than that furnished by the responsible party shall be used with the device. The use of a permanently attached antenna or of an antenna that uses a unique coupling to the intentional radiator, the manufacturer may design the unit so that a broken antenna can be replaced by the user, but the use of a standard antenna jack or electrical connector is prohibited.	
15.247(c) (1)(i) requirement: (i) Systems operating in the 2400-2483.5 MHz band that is used exclusively for fixed. Point-to-point operations may employ transmitting antennas with directional gain greater than 6dBi provided the maximum conducted output power of the intentional radiator is reduced by 1 dB for every 3 dB that the directional gain of the antenna exceeds 6dBi.	
EUT Antenna:	
The antenna is FPC Antenna, the best case gain of the antenna is 2.0dBi, reference to the appendix II for details.	



12. TEST SETUP PHOTO

Reference to the appendix I for details.

13. EUT CONSTRUCTIONAL DETAILS

Reference to the appendix II for details.

***** END OF REPORT *****