

FCC TEST REPORT

FCC ID:2BHWD-700

Product : Tire pressure monitor
Model Name : 700
Brand : N/A
Report No. : NCT24029472E

Prepared for

Shenzhen Baoan District Tesda Electronics Co., Ltd.

**201, Building B, Shanggaotian Industrial Zone, Gushu Community, Xixiang Street,
Bao'an District, Shenzhen**

Prepared by

Shenzhen NCT Testing Technology Co., Ltd.

**A101&2F B2, Fuqiao 6th Area, Xintian Community, Fuhai Street, Baoan District,
Shenzhen, People's Republic of China**

TEL: 400-8868-419

FAX: 86-755-27790922

1 TEST RESULT CERTIFICATION

Applicant's name : Shenzhen Baoan District Tesda Electronics Co., Ltd.
Address : 201, Building B, Shanggaotian Industrial Zone, Gushu Community, Xixiang Street, Bao'an District, Shenzhen
Manufacture's name : Shenzhen Baoan District Tesda Electronics Co., Ltd.
Address : 201, Building B, Shanggaotian Industrial Zone, Gushu Community, Xixiang Street, Bao'an District, Shenzhen
Product name : Tire pressure monitor
Model name : 700
Standards : FCC CFR47 Part 15 Section 15.231
Test procedure : ANSI C63.10:2013
Date of test : Jul. 12, 2024- Jul. 26, 2024
Date of Issue : Jul. 26, 2024

This device described above has been tested by NCT, and the test results show that the equipment under test (EUT) is in compliance with the FCC requirements. And it is applicable only to the tested sample identified in the report.

This report shall not be reproduced except in full, without the written approval of NCT, this document may be altered or revised by NCT, personal only, and shall be noted in the revision of the document.

Test Engineer:

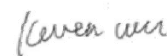

Keven Wu / Engineer

Technical Manager:



Henry Wang / Manager

Table of Contents		Page
1	TEST RESULT CERTIFICATION	2
2.	SUMMARY OF TEST RESULTS	5
2.1	TEST FACILITY	6
2.2	MEASUREMENT UNCERTAINTY	6
3.	GENERAL INFORMATION	7
3.1	GENERAL DESCRIPTION OF EUT	7
3.2	DESCRIPTION OF TEST MODES	8
3.3	BLOCK DIGRAM SHOWING THE CONFIGURATION OF SYSTEM TESTED	8
3.4	DESCRIPTION OF SUPPORT UNITS	8
3.5	EQUIPMENTS LIST FOR ALL TEST ITEMS	9
4.	EMC EMISSION TEST	11
4.1	CONDUCTED EMISSION MEASUREMENT	11
4.1.1	POWER LINE CONDUCTED EMISSION LIMITS	11
4.1.2	TEST PROCEDURE	12
4.1.3	DEVIATION FROM TEST STANDARD	12
4.1.4	TEST SETUP	12
4.1.5	EUT OPERATING CONDITIONS	12
4.1.6	TEST RESULTS	12
	THE EUT WITH DC 3.0V FORM BATTERY. SO THIS TEST ITEM NOT APPLICABLE	12
4.2	RADIATED EMISSION MEASUREMENT	13
4.2.1	RADIATED EMISSION LIMITS	13
4.2.2	TEST PROCEDURE	14
4.2.3	TEST SETUP	15
4.2.4	EUT OPERATING CONDITIONS	16
4.2.5	TEST RESULTS	16
5.	BANDWIDTH TEST	20
5.1	APPLIED PROCEDURES / LIMIT	20
5.2	TEST PROCEDURE	20
5.3	DEVIATION FROM STANDARD	20
5.4	TEST SETUP	20
5.5	EUT OPERATION CONDITIONS	20
5.6	TEST RESULTS	21
6.	CALCULATION OF AVERAGE FACTOR	22
7.	TRANSMISSION CEASE TIME	25
7.1	APPLICABLE STANDARD	25

7.2 TEST PROCEDURE	25
7.3 DEVIATION FROM STANDARD	25
7.4 TEST SETUP	25
7.5 EUT OPERATION CONDITIONS	25
7.6 TEST RESULTS	25
8. ANTENNA REQUIREMENT	27
9. TEST SETUP PHOTO	27

2. SUMMARY OF TEST RESULTS

Test procedures according to the technical standards:

FCC Part15 (15.231) , Subpart C			
Standard Section	Test Item	Judgment	Remark
15.207	Conducted Emission	N/A	
15.209,15.231b	Fundamental &Radiated Spurious Emission Measurement	PASS	
15.231c	Occupy Bandwidth	PASS	
15.203	Antenna Requirement	PASS	
15.231(a)	Transmission cease time	PASS	

NOTE:

(1) " N/A" denotes test is not applicable in this Test Report

2.1 TEST FACILITY

Site Description

EMC Lab. : Accredited by CNAS, 2022-09-27
 The certificate is valid until 2028.01.07
 The Laboratory has been assessed and proved to be in compliance with
 CNAS-CL01:2006 (identical to ISO/IEC 17025:2017)
 The Certificate Registration Number is L8251
 Designation Number: CN1347
 Test Firm Registration Number: 894804
 Accredited by A2LA, June 14, 2023
 The Certificate Registration Number is 6837.01

Accredited by Industry Canada, November 09, 2018
 The Conformity Assessment Body Identifier is CN0150
 Company Number: 30806

Name of Firm : Shenzhen NCT Testing Technology Co., Ltd.
 Site Location : A101&2F B2, Fuqiao 6th Area, Xintian Community, Fuhai Street, Baoan District, Shenzhen, People's Republic of China

2.2 MEASUREMENT UNCERTAINTY

The reported uncertainty of measurement $y \pm U$ · where expanded uncertainty U is based on a standard uncertainty multiplied by a coverage factor of $k=2$ · providing a level of confidence of approximately 95 % .

Parameter	Uncertainty
RF output power, conducted	$\pm 1.0\text{dB}$
Power Spectral Density, conducted	$\pm 2.2\text{dB}$
Radio Frequency	$\pm 1 \times 10^{-6}$
Bandwidth	$\pm 1.5 \times 10^{-6}$
Time	$\pm 2\%$
Duty Cycle	$\pm 2\%$
Temperature	$\pm 1^\circ\text{C}$
Humidity	$\pm 5\%$
DC and low frequency voltages	$\pm 3\%$
Conducted Emissions (150kHz~30MHz)	$\pm 3.64\text{dB}$
Radiated Emission(below 30MHz)	$\pm 4.02\text{dB}$
Radiated Emission(30MHz~1GHz)	$\pm 5.03\text{dB}$
Radiated Emission(1GHz~25GHz)	$\pm 4.74\text{dB}$
Remark: The coverage Factor (k=2), and measurement Uncertainty for a level of Confidence of 95%	

3. GENERAL INFORMATION**3.1 GENERAL DESCRIPTION OF EUT**

Product Name	:	Tire pressure monitor
Model Name	:	700
Sample ID	:	NCT24029472-001#
Sample(s) Status:	:	Engineer sample
Series Model	:	N/A
Model Different.:	:	N/A
Operating frequency	:	433.92 MHz
Type of Modulation	:	FSK
Antenna installation	:	PCB Antenna
Antenna Gain	:	-22.23dBi
Power supply	:	3.0Vd.c

3.2 DESCRIPTION OF TEST MODES

For All Emission	
Final Test Mode	Description
Transmitting mode	Keep the EUT in continuously transmitting mode

Note:

- (1) Fully-charged battery is used during the test

3.3 BLOCK DIGRAM SHOWING THE CONFIGURATION OF SYSTEM TESTED

Conducted Emission Test

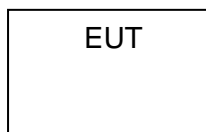

Spurious emissions

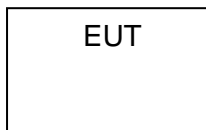

3.4 DESCRIPTION OF SUPPORT UNITS

The EUT has been tested as an independent unit together with other necessary accessories or support units. The following support units or accessories were used to form a representative test configuration during the tests.

Item	Equipment	Mfr/Brand	Model/Type No.	Series No.	Note

Item	Shielded Type	Ferrite Core	Length	Note

Note:

- (1) The support equipment was authorized by Declaration of Confirmation.
- (2) For detachable type I/O cable should be specified the length in cm in 『Length』 column.
- (3) “YES” is means “shielded” “with core”; “NO” is means “unshielded” “without core”.

3.5 EQUIPMENTS LIST FOR ALL TEST ITEMS

Radiated emission & Radio Frequency Test Equipment

Name	Model No.	Serial No.	Manufacturer	Date of Cal.	Due Date
966 Shielded Room	966 Room	/	EMToni	2022/5/31	2025/5/30
EMI Test Receiver	ESCI	101178	Rohde & Schwarz	2024/6/21	2025/6/20
Amplifi (30MHz-1GHz)	BBV 9743 B	00374	SCHNWARZBECK	2024/6/21	2025/6/20
Bilog Antenna (30MHz-1GHz)	VULB9162	00473	SCHNWARZBECK	2023/3/19	2025/3/18
Horn antenna (1GHz-18GHz)	BBHA 9120 D	02622	SCHNWARZBECK	2023/3/19	2025/3/18
Pream plifier (1GHz-18GHz)	BBV 9718D	0024	SCHNWARZBECK	2024/6/21	2025/6/20
Spectrum Analyze (10Hz-40GHz)	FSV 40	100952	Rohde & Schwarz	2024/6/21	2025/6/20
Pream plifier (18GHz-40GHz)	BBV 9721	0056	SCHNWARZBECK	2024/6/21	2025/6/20
Double Ridge Guide Horn Antenna (18GHz-40GHz)	SAS-574	588	A.H.System	2023/3/19	2025/3/18
Loop Antenna (9KHz-30MHz)	FMZB 1513-60	00115	SCHNWARZBECK	2024/6/21	2025/6/20
Amplifier (9KHz-30MHz)	BBV 9745	00109	CHNWARZBECK	2024/6/21	2025/6/20
MXG Signal Analyzer	N9020A	MY50510202	Agilent	2024/6/21	2025/6/20
MXG Vector Signal Generator	N5182A	MY50140020	Agilent	2024/6/21	2025/6/20
MXG Analog Signal Generator	N5181A	MY47420919	Agilent	2024/6/21	2025/6/20
Power Sensor	TR1029-2	512364	Techoy	2024/6/21	2025/6/20
RF Swith	TR1029-1	512364	Techoy	2024/6/21	2025/6/20
Cable	DA800- 4000MM	NA	DA	2024/6/21	2025/6/20
Cable	DA800- 11000MM	NA	DA	2024/6/21	2025/6/20

Conducted emission Test Equipment

Name	Model No.	Serial No.	Manufacturer	Date of Cal.	Due Date
944 Shielded Room	944 Room	/	EMToni	2022/5/31	2025/5/30
EMI Test Receiver	ESPI	101604	Rohde & Schwarz	2024/6/21	2025/6/20
LISN	ENV 216	102796	Rohde & Schwarz	2024/6/21	2025/6/20
LISN	VN1-13S	004023	CRANAGE	2024/6/21	2025/6/20
Cable	RG223-1500MM	NA	RG	2024/6/21	2025/6/20

Other

Item	Name	Manufacturer	Model	Software version
1	EMC Conduction Test System	AUDIX	e3	6.120718
2	EMC radiation test system	AUDIX	e3	6.120718
3	RF test system	TACHOY	RFTest	V1.0.0
4	RF communication test system	TACHOY	RFTest	V1.0.0

4. EMC EMISSION TEST

4.1 CONDUCTED EMISSION MEASUREMENT

Test Requirement:	FCC Part15 C Section 15.207
Test Method:	ANSI C63.10:2013
Test Frequency Range:	150KHz to 30MHz
Receiver setup:	RBW=9KHz, VBW=30KHz, Sweep time=auto

4.1.1 POWER LINE CONDUCTED EMISSION LIMITS

(Frequency Range 150KHz-30MHz)

FREQUENCY (MHz)	Limit (dBuV)		Standard
	Quasi-peak	Average	
0.15 -0.5	66 - 56 *	56 - 46 *	FCC
0.50 -5.0	56.00	46.00	FCC
5.0 -30.0	60.00	50.00	FCC

Note:

- (1) The tighter limit applies at the band edges.
- (2) The limit of " * " marked band means the limitation decreases linearly with the logarithm of the frequency in the range.

The following table is the setting of the receiver

Receiver Parameters	Setting
Attenuation	10 dB
Start Frequency	0.15 MHz
Stop Frequency	30 MHz
IF Bandwidth	9 kHz

4.1.2 TEST PROCEDURE

- The EUT was placed 0.8 meters from the horizontal ground plane with EUT being connected to the power mains through a line impedance stabilization network (LISN). All other support equipments powered from additional LISN(s). The LISN provide 50 Ohm/ 50uH of coupling impedance for the measuring instrument.
- Interconnecting cables that hang closer than 40 cm to the ground plane shall be folded back and forth in the center forming a bundle 30 to 40 cm long.
- I/O cables that are not connected to a peripheral shall be bundled in the center. The end of the cable may be terminated, if required, using the correct terminating impedance. The overall length shall not exceed 1 m.
- LISN at least 80 cm from nearest part of EUT chassis.
- For the actual test configuration, please refer to the related Item –EUT Test Photos.

4.1.3 DEVIATION FROM TEST STANDARD

No deviation

4.1.4 TEST SETUP

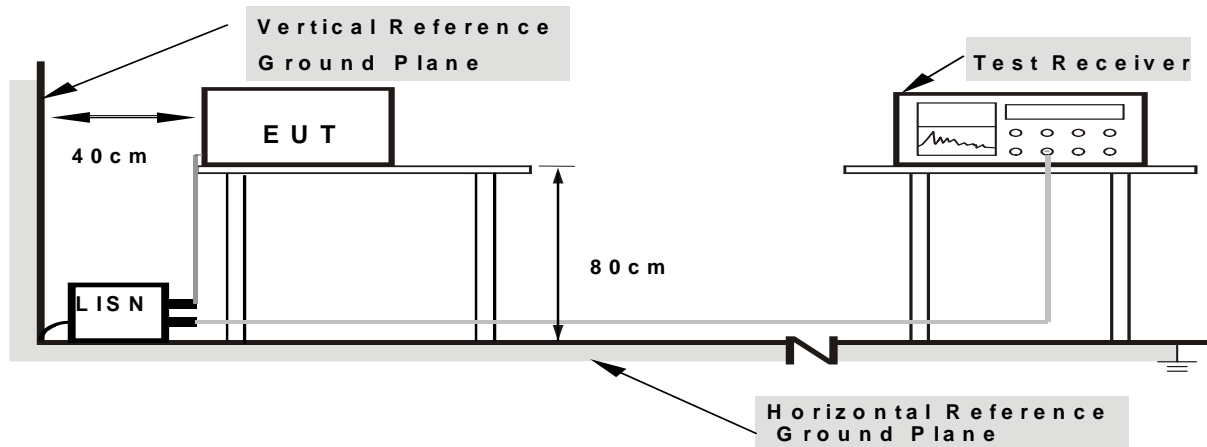

- Note:**
- Support units were connected to second LISN.
 - Both of LISNs (AMN) are 80 cm from EUT and at least 80 from other units and other metal planes

4.1.5 EUT OPERATING CONDITIONS

The EUT was configured for testing in a typical fashion (as a customer would normally use it). The EUT has been programmed to continuously transmit during test. This operating condition was tested and used to collect the included data.

4.1.6 TEST RESULTS

The EUT with DC 3.0V Form Battery. So this test item not applicable

4.2 RADIATED EMISSION MEASUREMENT

Test Requirement:	FCC Part15 C Section 15.209				
Test Method:	ANSI C63.10:2013				
Test Frequency Range:	9kHz to 25GHz				
Test site:	Measurement Distance: 3m				
Receiver setup:	Frequency	Detector	RBW	VBW	Value
	9KHz-150KHz	Quasi-peak	200Hz	600Hz	Quasi-peak
	150KHz-30MHz	Quasi-peak	9KHz	30KHz	Quasi-peak
	30MHz-1GHz	Quasi-peak	100KHz	300KHz	Quasi-peak
	Above 1GHz	Peak	1MHz	3MHz	Peak
Peak		1MHz	10Hz	Average	

4.2.1 RADIATED EMISSION LIMITS

20dBc in any 100 kHz bandwidth outside the operating frequency band. In case the emission fall within the restricted band specified on 15.205(a), then the 15.231(b) limit in the table below has to be followed.

Frequencies(MHz)	Field Strength(micorvolts/meter)	Measurement Distance(meters)
0.009~0.490	2400/F(KHz)	300
0.490~1.705	24000/F(KHz)	30
1.705~30.0	30	30
30~88	100	3
88~216	150	3
216~960	200	3
Above 960	500	3

LIMITS OF RADIATED EMISSION MEASUREMENT

FREQUENCY (MHz)	Limit (dBuV/m) (at 3M)	
	PEAK	AVERAGE
Above 1000	74	54

Notes:

- (1) The limit for radiated test was performed according to FCC PART 15C.
- (2) The tighter limit applies at the band edges.
- (3) Emission level (dBuV/m)=20log Emission level (uV/m).

FUNDAMENTAL AND HARMONICS EMISSION LIMITS

Fundamental frequency (MHz)	Field strength of fundamental (microvolts/meter)	Field strength of spurious emissions (microvolts/meter)
40.66-40.70	2,250	225
70-130	1,250	125
130-174	¹ 1,250 to 3,750	¹ 125 to 375
174-260	3,750	375
260-470	¹ 3,750 to 12,500	¹ 375 to 1,250
Above 470	12,500	1,250

Note: Linear interpolations

FREQUENCY RANGE OF RADIATED MEASUREMENT (For unintentional radiators)

Highest frequency generated or Upper frequency of measurement used in the device or on which the device operates or tunes (MHz)	Range (MHz)
Below 1.705	30
1.705 – 108	1000
108 – 500	2000
500 – 1000	5000
Above 1000	5 th harmonic of the highest frequency or 40 GHz, whichever is lower

Spectrum Parameter	Setting
Attenuation	Auto
Start Frequency	1000 MHz
Stop Frequency	10th carrier harmonic
RBW / VBW setting	1 MHz / 1 MHz for Peak, 1 MHz / 10Hz for Average

Receiver Parameter	Setting
Attenuation	Auto
Start ~ Stop Frequency	9kHz~150kHz / RB 200Hz for QP
Start ~ Stop Frequency	150kHz~30MHz / RB 9kHz for QP
Start ~ Stop Frequency	30MHz~1000MHz / RB 120kHz for QP

4.2.2 TEST PROCEDURE

- The measuring distance of at 3 m shall be used for measurements at frequency up to 1GHz. For frequencies above 1GHz, any suitable measuring distance may be used.
- The EUT was placed on the top of a rotating table 0.8 meters above the ground at a 3 meter open area test site. The table was rotated 360 degrees to determine the position of the highest radiation.
- The height of the equipment or of the substitution antenna shall be 0.8 m; above 1GHz, the height was 1.5m, the height of the test antenna shall vary between 1 m to 4 m. Both horizontal and vertical polarizations of the antenna are set to make the measurement.
- The initial step in collecting conducted emission data is a spectrum analyzer peak detector mode pre-scanning the measurement frequency range. Significant peaks are then marked and then Quasi Peak detector mode re-measured.
- If the Peak Mode measured value compliance with and lower than Quasi Peak Mode Limit, the EUT shall be deemed to meet QP Limits and then no additional QP Mode measurement performed.
- For the actual test configuration, please refer to the related Item –EUT Test Photos.

Note:

Both horizontal and vertical antenna polarities were tested and performed pretest to three orthogonal axis. The worst case was X axis and the emissions were reported

4.2.3 TEST SETUP

(A) Radiated Emission Test-Up Frequency Below 30MHz

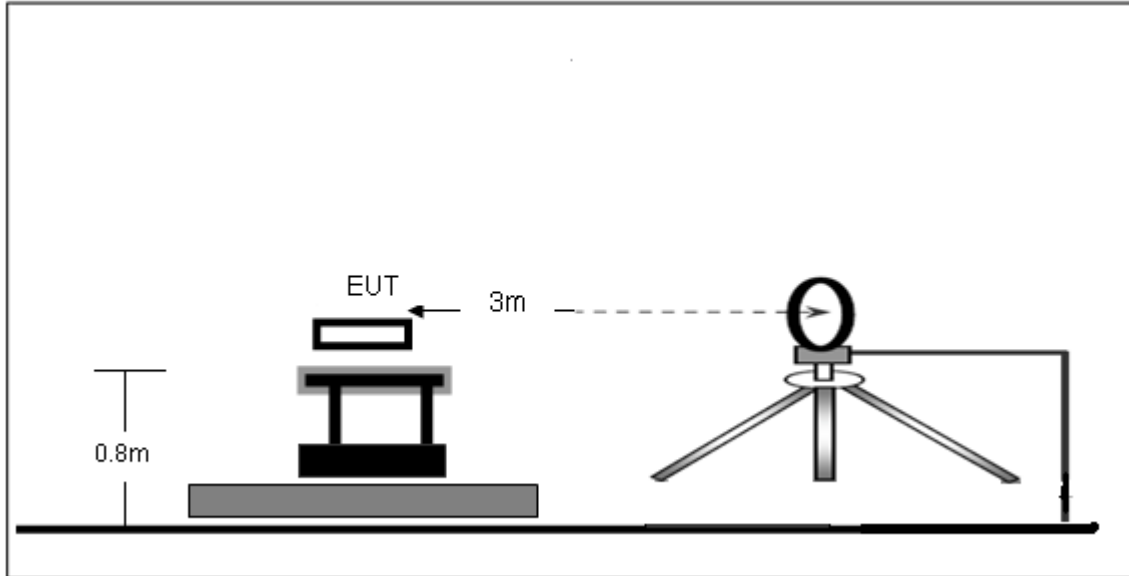

(B) Radiated Emission Test-Up Frequency 30MHz~1GHz

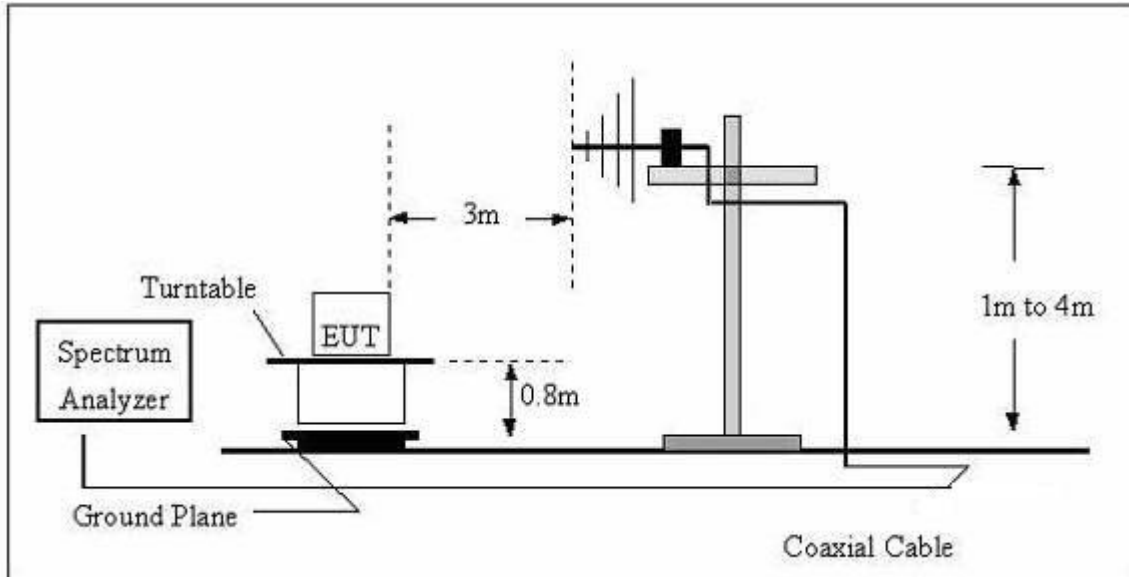

(C) Radiated Emission Test-Up Frequency Above 1GHz

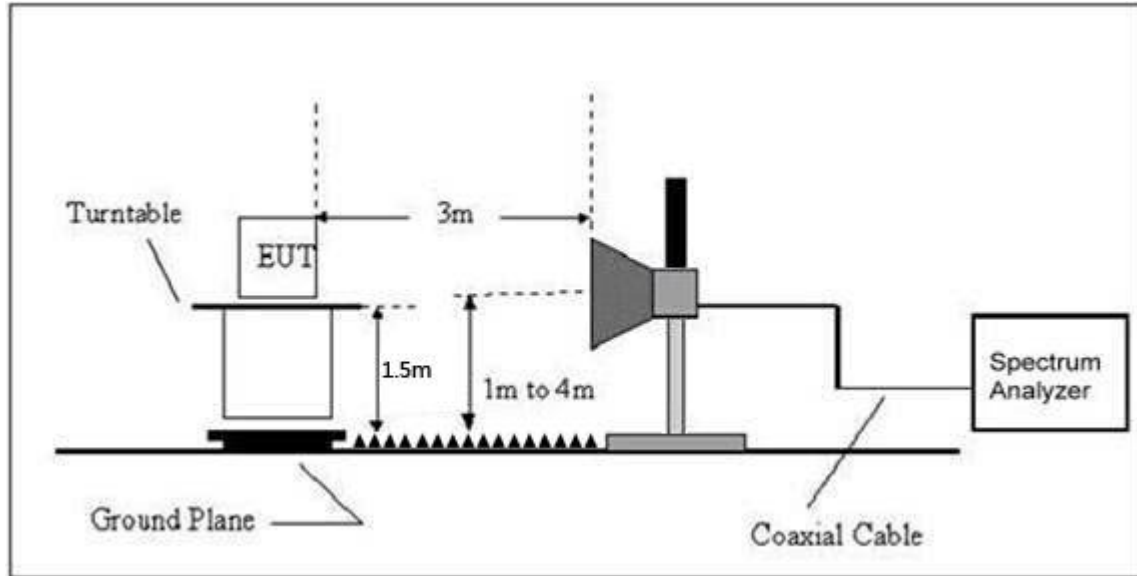

4.2.4 EUT OPERATING CONDITIONS

The EUT tested system was configured as the statements of 2.4 Unless otherwise a special operating condition is specified in the follows during the testing.

4.2.5 TEST RESULTS

Radiated Spurious Emission (Below 9KHz – 30MHz)

Temperature :	26 °C	Relative Humidity :	54%
Pressure :	101 kPa	Polarization :	---
Test Voltage :	DC 3.0V		
Test Mode :	TX Mode		

Freq.	Reading	Limit	Margin	State
(MHz)	(dBuV/m)	(dBuV/m)	(dB)	P/F
--	--	--	--	PASS
--	--	--	--	PASS

NOTE:

The amplitude of spurious emissions which are attenuated by more than 20dB below the permissible value has no need to be reported.

Distance extrapolation factor = $40 \log (\text{specific distance}/\text{test distance})(\text{dB})$;

Limit line = specific limits(dBuv) + distance extrapolation factor.

Radiated Spurious Emission (Between 30MHz – 1GHz)

Temperature :	26 °C	Relative Humidity :	54%
Pressure :	101 kPa	Polarization :	Horizontal
Test Voltage :	DC 3.0V		
Test Mode :	TX Mode		

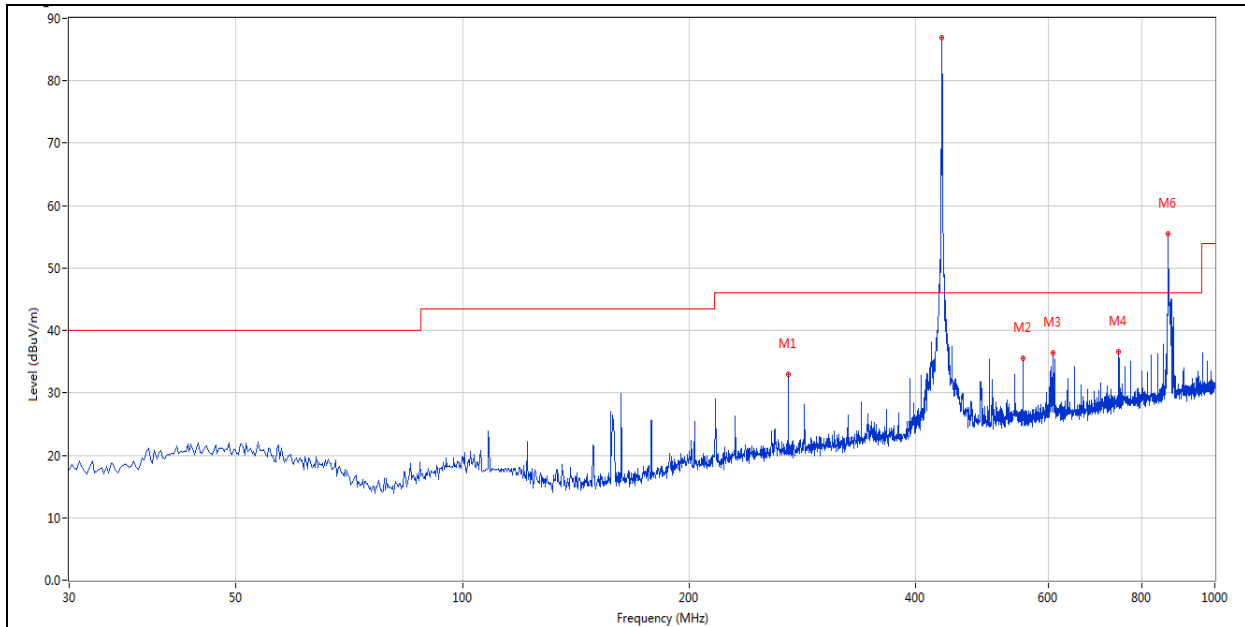

No.	Frequency (MHz)	Results (dBuV/m)	Factor (dB)	Limit (dBuV/m)	Margin (dB)	Detector	ANT	Verdict
1	271.227	33.92	-11.72	46.0	-12.08	Peak	Horizontal	Pass
2	433.920	86.94	-8.03	100.83	-13.89	Peak	Horizontal	Pass
3	555.851	35.63	-6.22	46.0	-10.37	Peak	Horizontal	Pass
4	609.430	36.43	-5.02	46.0	-9.57	Peak	Horizontal	Pass
5	745.681	36.59	-3.42	46.0	-9.41	Peak	Horizontal	Pass
6	867.840	56.52	-2.35	80.83	-24.31	Peak	Horizontal	Pass

Temperature :	26 °C	Relative Humidity :	54%
Pressure :	101 kPa	Polarization :	Vertical
Test Voltage :	DC 3.0V		
Test Mode :	TX Mode		

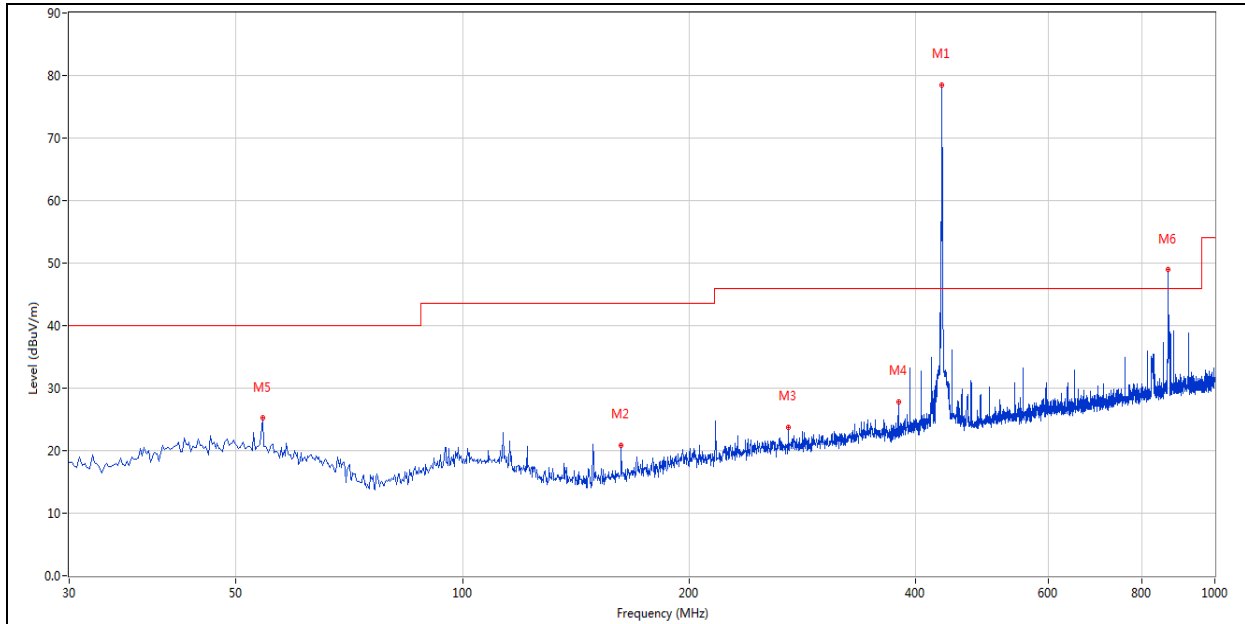

No.	Frequency (MHz)	Results (dBuV/m)	Factor (dB)	Limit (dBuV/m)	Margin (dB)	Detector	ANT	Verdict
1	433.920	78.74	-8.03	100.83	-22.09	Peak	Vertical	Pass
2	162.614	20.78	-16.38	43.5	-22.72	Peak	Vertical	Pass
3	271.227	23.77	-9.22	46.0	-22.23	Peak	Vertical	Pass
4	379.598	26.69	-7.99	46.0	-19.31	Peak	Vertical	Pass
5	54.244	24.51	-11.60	40.0	-15.49	Peak	Vertical	Pass
6	867.840	49.07	-2.35	80.83	-31.76	Peak	Vertical	Pass

For average Emission

Frequency MHz	Peak Level dBuV/m	Duty cycle factor	AverageLevel dBuV/m	Limit AV	Margin	Polarization
433.92	86.94	-23.66	63.28	80.83	-17.55	Horizontal
867.84	56.52	-23.66	32.86	60.83	-27.97	Horizontal

Notes: 1. Average emission Level = Peak Level + Duty cycle factor
 2. Duty cycle level please see clause 6.

Frequency MHz	Peak Level dBuV/m	Duty cycle factor	AverageLevel dBuV/m	Limit AV	Margin	Polarization
433.92	78.74	-23.66	55.08	80.83	-25.75	Vertical
867.84	49.07	-23.66	25.41	60.83	-35.42	Vertical

Notes: 1. Average emission Level = Peak Level + Duty cycle factor
 2. Duty cycle level please see clause 6.

Radiated Spurious Emission (Above1GHz)

Frequency MHz	Peak Level dBuV/m	Duty cycle factor	Average Level dBuV/m	Limit		Margin dB		Polarization
				PK	AV	PK	AV	
1301.76	42.21	-23.66	18.55	74	54	-31.79	-35.45	Vertical
1735.68	38.75	-23.66	15.09	74	54	-35.25	-38.91	Vertical
1301.76	41.02	-23.66	17.36	74	54	-32.98	-36.64	Horizontal
1735.68	37.62	-23.66	13.96	74	54	-36.38	-40.04	Horizontal

Notes: 1. Average emission Level = Peak Level + Duty cycle factor
 2. Duty cycle level please see clause 6.

Note: Other emissions are attenuated 20dB below the limits, so does not reported.

5. BANDWIDTH TEST

5.1 APPLIED PROCEDURES / LIMIT

According to FCC 15.231(c) requirement:

The bandwidth of the emission shall be no wider than 0.25% of the center frequency for devices operating between 70 MHz to 900 MHz. Those devices operating above 900 MHz, the emission spurious shall be no wider than 0.5% of the center frequency. Bandwidth is determined at the points 20 dB down from the modulated carrier.

B.W (20dBc) Limit = 0.25% * f(MHz) = 0.25% * 433.92MHz = 1.085MHz

Spectrum Parameter	Setting
Attenuation	Auto
Span Frequency	> Measurement Bandwidth or Channel Separation
RBW	30kHz
VBW	100kHz
Detector	Peak
Trace	Max Hold
Sweep Time	Auto

5.2 TEST PROCEDURE

- a. The EUT was directly connected to the spectrum analyzer and antenna output port as show in the block diagram below,
- b. Spectrum Setting : RBW= 30kHz, VBW≥ 100kHz, Sweep time = Auto.

5.3 DEVIATION FROM STANDARD

No deviation.

5.4 TEST SETUP



5.5 EUT OPERATION CONDITIONS

The EUT tested system was configured as the statements of 2.4 Unless otherwise a special operating condition is specified in the follows during the testing.

5.6 TEST RESULTS

Temperature :	26 °C	Relative Humidity :	54%
Pressure :	101kPa	Test Voltage :	DC 3.0V
Test Mode :	TX Mode		

Frequency	20dB Bandwidth (MHz)	Limit (MHz)	Result
433.92MHz	0.131	1.085	PASS

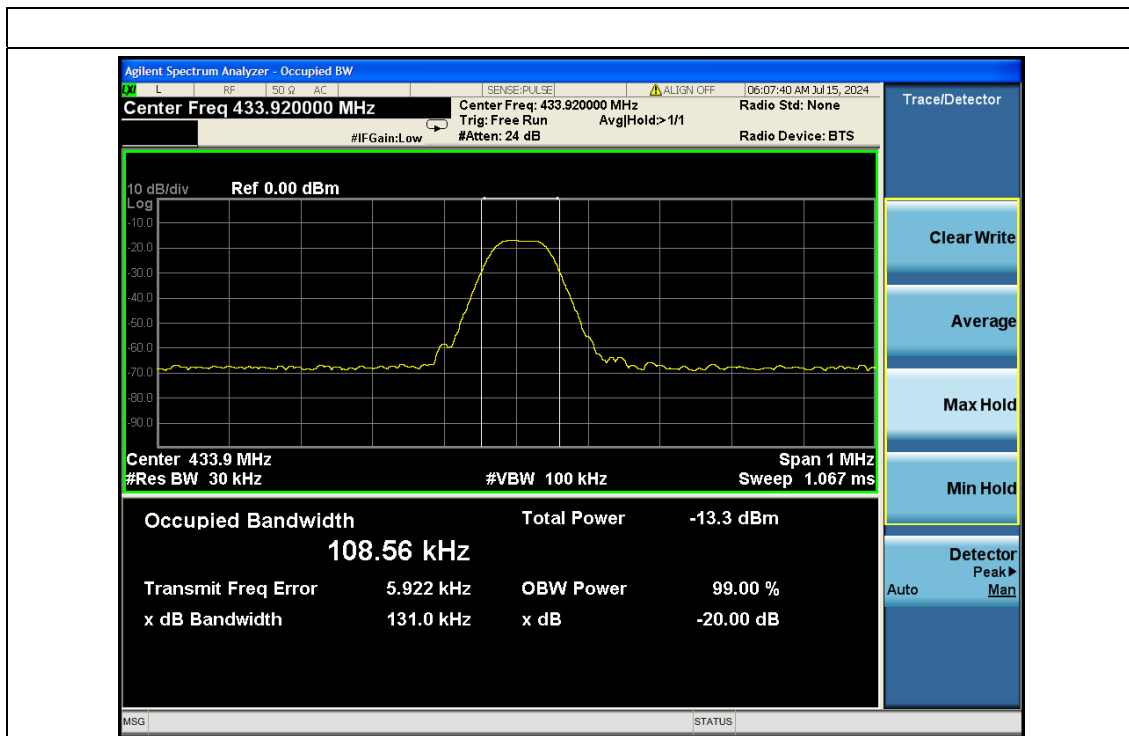

6. CALCULATION OF AVERAGE FACTOR

The output field strengths of specification in accordance with the FCC rules specify measurements with an average detector. During the test, a spectrum analyzer incorporating a peak detector was used. Therefore, a reduction factor can be applied to the resultant peak signal level and compared to the limit for measurement instrumentation incorporating an average detector.

Duty Cycle:

The duty cycle is simply the on time divided by the period:

The duration of one cycle = 100ms

Effective period of the cycle =6.56ms

Duty Cycle =6.56ms/100ms =0.0656=6.56%

Duty Cycle factor= $20\lg(\text{Duty Cycle})=20\lg(0.0656)=-23.66\text{dB}$

Average=Peak+ Duty Cycle factor

Pulse Desensitization Correction Factor

Pulse Width(PW)=6.56ms

$2/PW=2/6.56\text{ms}=0.305\text{kHz}$

$\text{RBW}(100\text{kHz}) > 2/PW (0.305\text{kHz})$

Therefore PDCF is not needed

Test plot as follows:

Temperature :	26 °C	Relative Humidity :	54%
Pressure :	101kPa	Test Voltage :	DC 3.0V
Test Mode :	TX Mode		

The duration of one cycle

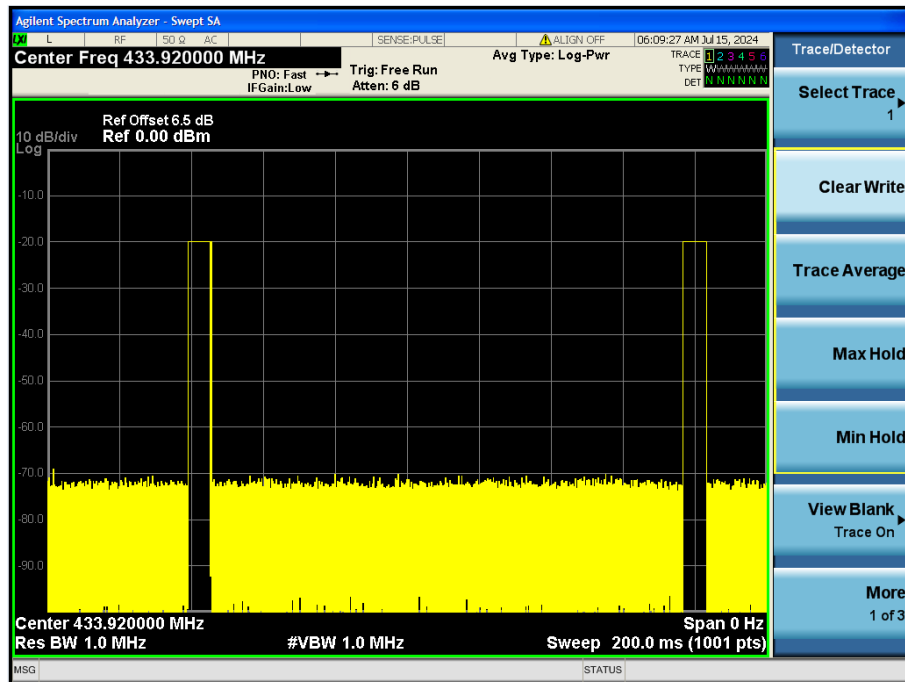
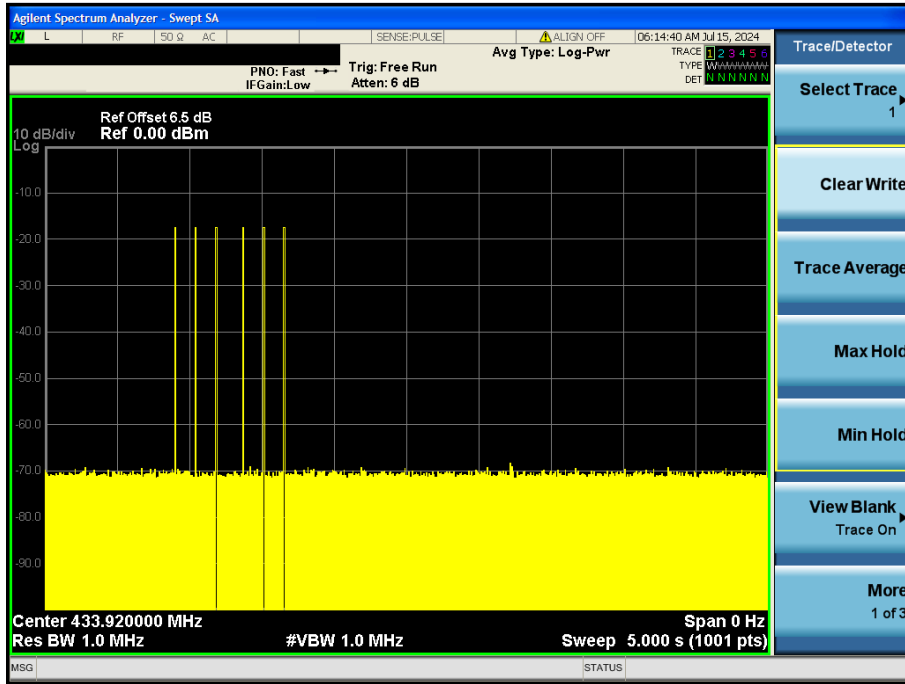

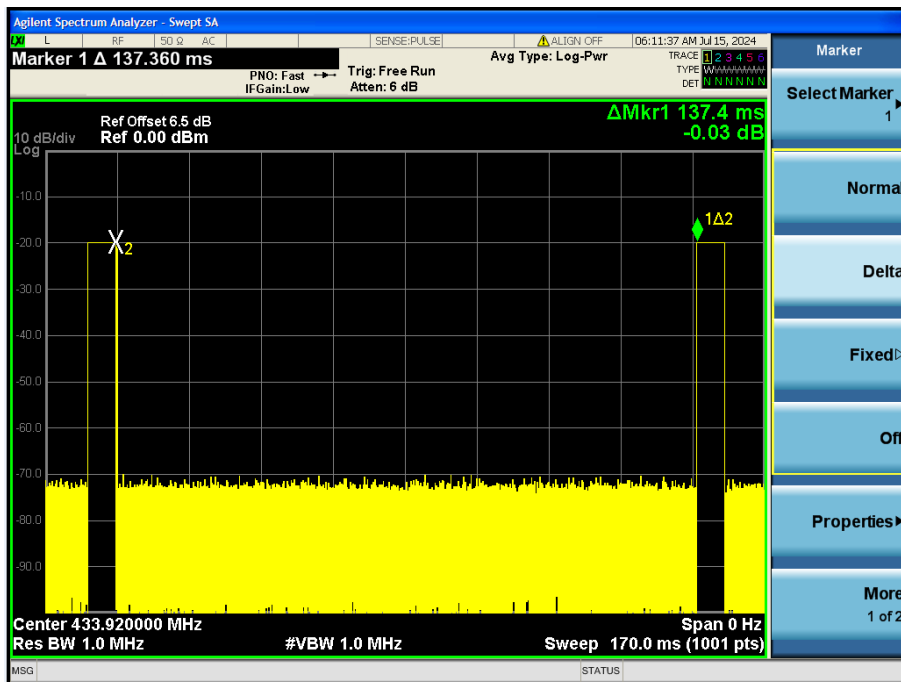
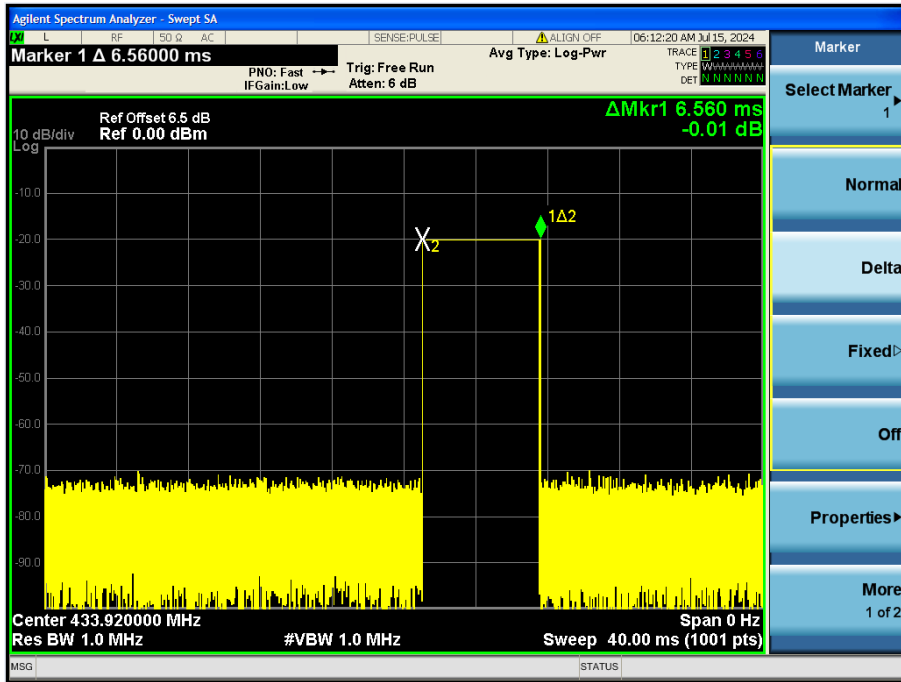

7. TRANSMISSION CEASE TIME

7.1 APPLICABLE STANDARD

According to FCC 15.231(a) requirement:

A transmitter activated automatically shall cease transmission within 5 seconds after activation.

7.2 TEST PROCEDURE

Check the calibration of the measuring instrument using either an internal calibrator or a known signal from an external generator.

- 1.Position the EUT without connection to measurement instrument. Turn on the EUT and connect its antenna terminal to measurement instrument via a low loss cable. Then set it to any one measured frequency within its operating range, and make sure the instrument is operated in its linear range.
- 2.Set RBW to 1MHz and VBW of spectrum analyzer to 1 MHz
- 3.Measure the highest amplitude appearing on spectral display and set it as a reference level. Plot the graph with marking the highest point and edge frequency.
- 4.Repeat above procedures until all measured frequencies were complete.

7.3 DEVIATION FROM STANDARD

No deviation.

7.4 TEST SETUP

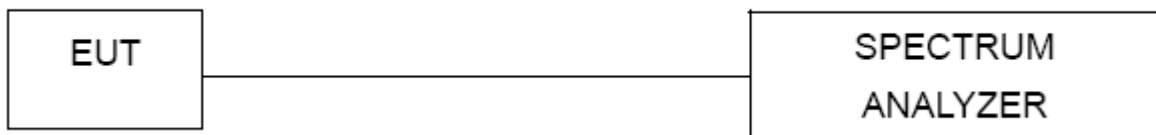

7.5 EUT OPERATION CONDITIONS

The EUT tested system was configured as the statements of 2.4 Unless otherwise a special operating condition is specified in the follows during the testing.

7.6 TEST RESULTS

Dwell time (second)	Limit (second)	Result
780ms	<5s	Pass

Test plot as follows:

A transmitter activated automatically shall cease transmission within 5 seconds after activation.

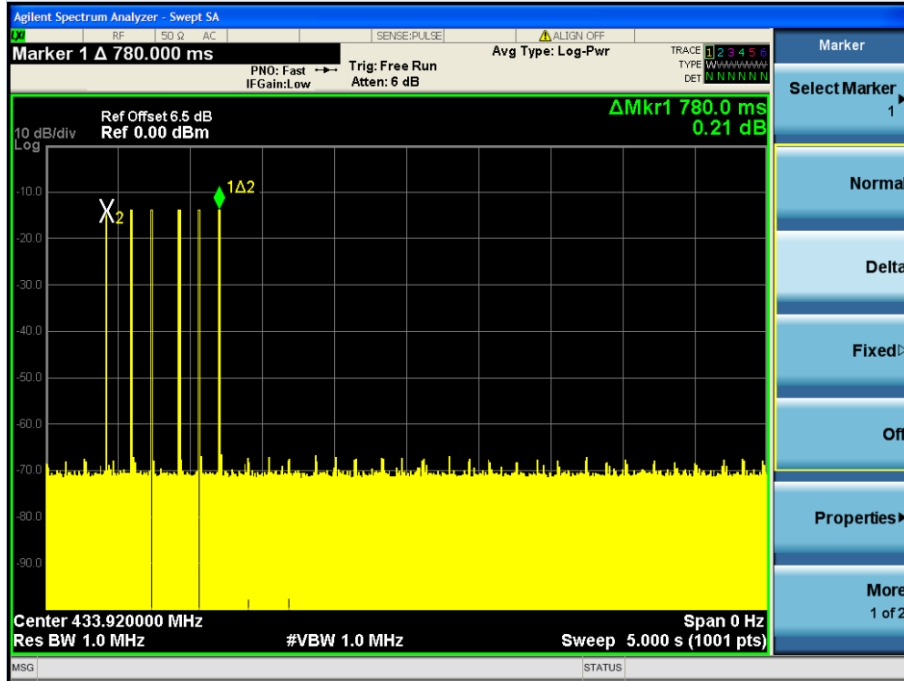

8. ANTENNA REQUIREMENT

Standard requirement:	FCC Part15 C Section 15.203
15.203 requirement: An intentional radiator shall be designed to ensure that no antenna other than that furnished by the responsible party shall be used with the device. The use of a permanently attached antenna or of an antenna that uses a unique coupling to the intentional radiator, the manufacturer may design the unit so that a broken antenna can be replaced by the user, but the use of a standard antenna jack or electrical connector is prohibited.	
EUT Antenna:	
The antennas are PCB antenna, the best case gain of the antennas are -22.23dBi, reference to the attachment for details	

9. TEST SETUP PHOTO

Reference to the Test photo attachment for details.

***** END OF REPORT *****