



# FCC Radio Test Report

## FCC ID: 2BHQS-PSM803

This report concerns: Original Grant

**Project No.** : 2405H020  
**Equipment** : Smart Module  
**Brand Name** : N/A  
**Test Model** : PSM803  
**Series Model** : N/A  
**Applicant** : Phoenix Season LLC  
**Address** : 113 Cruiser Irvine, California 92618 United States  
**Manufacturer** : Phoenix Season LLC  
**Address** : 113 Cruiser Irvine, California 92618 United States  
**Date of Receipt** : May 16, 2024  
**Date of Test** : May 20, 2024~Jul. 31, 2024  
**Issued Date** : Sep. 25, 2024  
**Report Version** : R01  
**Test Sample** : Engineering Sample No.: SH202406256 for radiated,  
SH2024051641 for conducted, SH20240517566 for adapter.  
**Standard(s)** : FCC CFR Title 47, Part 15, Subpart C  
FCC KDB 558074 D01 15.247 Meas Guidance v05r02  
ANSI C63.10-2013

The above equipment has been tested and found compliance with the requirement of the relative standards by BTL Inc. (Shanghai)

*Louis Li*

Prepared by : Louis Li

*Riley Wei*

Approved by : Riley Wei

Add: No. 29, Jintang Road, Tangzhen Industry Park, Pudong New Area, Shanghai 201210, China.

Tel: +86-021-61765666

Web: [www.newbtl.com](http://www.newbtl.com)

Service mail: [btl\\_qa@newbtl.com](mailto:btl_qa@newbtl.com)

**Declaration**

**BTL** represents to the client that testing is done in accordance with standard procedures as applicable and that test instruments used has been calibrated with standards traceable to international standard(s) and/or national standard(s).

**BTL's** reports apply only to the specific samples tested under conditions. It is manufacture's responsibility to ensure that additional production units of this model are manufactured with the identical electrical and mechanical components. **BTL** assumes no responsibility for the data provided by the customer, any statements, inferences or generalizations drawn by the customer or others from the reports issued by **BTL**.

The report must not be used by the client to claim product certification, approval, or endorsement by A2LA or any agency of the U.S. Government.

This report is the confidential property of the client. As a mutual protection to the clients, the public and ourselves, the test report shall not be reproduced, except in full, without our written approval.

**BTL's** laboratory quality assurance procedures are in compliance with the ISO/IEC 17025: 2017 requirements, and accredited by the conformity assessment authorities listed in this test report.

**BTL** is not responsible for the sampling stage, so the results only apply to the sample as received.

The information, data and test plan are provided by manufacturer which may affect the validity of results, so it is manufacturer's responsibility to ensure that the apparatus meets the essential requirements of applied standards and in all the possible configurations as representative of its intended use.

**Limitation**

For the use of the authority's logo is limited unless the Test Standard(s)/Scope(s)/Item(s) mentioned in this test report is (are) included in the conformity assessment authorities acceptance respective.

Please note that the measurement uncertainty is provided for informational purpose only and are not use in determining the Pass/Fail results.

<b>Table of Contents</b>	<b>Page</b>
<b>REPORT ISSUED HISTORY</b>	<b>6</b>
<b>1 . SUMMARY OF TEST RESULTS</b>	<b>7</b>
1.1 TEST FACILITY	8
1.2 MEASUREMENT UNCERTAINTY	8
1.3 TEST ENVIRONMENT CONDITIONS	8
<b>2 . GENERAL INFORMATION</b>	<b>9</b>
2.1 GENERAL DESCRIPTION OF EUT	9
2.2 DESCRIPTION OF TEST MODES	11
2.3 PARAMETERS OF TEST SOFTWARE	12
2.4 BLOCK DIAGRAM SHOWING THE CONFIGURATION OF SYSTEM TESTED	13
2.5 SUPPORT UNITS	13
<b>3 . RADIATED EMISSIONS</b>	<b>14</b>
3.1 LIMIT	14
3.2 TEST PROCEDURE	15
3.3 DEVIATION FROM TEST STANDARD	16
3.4 TEST SETUP	16
3.5 EUT OPERATING CONDITIONS	18
3.6 TEST RESULTS - 9 KHZ TO 30 MHZ	18
3.7 TEST RESULTS - 30 MHZ TO 1000 MHZ	18
3.8 TEST RESULTS - ABOVE 1000 MHZ	18
<b>4 . NUMBER OF HOPPING FREQUENCY</b>	<b>19</b>
4.1 LIMIT	19
4.2 TEST PROCEDURE	19
4.3 DEVIATION FROM STANDARD	19
4.4 TEST SETUP	19
4.5 EUT OPERATION CONDITIONS	19
4.6 TEST RESULTS	19
<b>5 . AVERAGE TIME OF OCCUPANCY</b>	<b>20</b>
5.1 LIMIT	20
5.2 TEST PROCEDURE	20
5.3 DEVIATION FROM STANDARD	20
5.4 TEST SETUP	20
5.5 EUT OPERATION CONDITIONS	20

<b>Table of Contents</b>	<b>Page</b>
5.6 TEST RESULTS	20
<b>6 . HOPPING CHANNEL SEPARATION</b>	<b>21</b>
6.1 LIMIT	21
6.2 TEST PROCEDURE	21
6.3 DEVIATION FROM STANDARD	21
6.4 TEST SETUP	21
6.5 EUT OPERATION CONDITIONS	21
6.6 TEST RESULTS	21
<b>7 . BANDWIDTH</b>	<b>22</b>
7.1 LIMIT	22
7.2 TEST PROCEDURE	22
7.3 DEVIATION FROM STANDARD	22
7.4 TEST SETUP	22
7.5 EUT OPERATION CONDITIONS	22
7.6 TEST RESULTS	22
<b>8 . MAXIMUM OUTPUT POWER</b>	<b>23</b>
8.1 LIMIT	23
8.2 TEST PROCEDURE	23
8.3 DEVIATION FROM STANDARD	23
8.4 TEST SETUP	23
8.5 EUT OPERATION CONDITIONS	23
8.6 TEST RESULTS	23
<b>9 . CONDUCTED SPURIOUS EMISSION</b>	<b>24</b>
9.1 LIMIT	24
9.2 TEST PROCEDURE	24
9.3 DEVIATION FROM STANDARD	24
9.4 TEST SETUP	24
9.5 EUT OPERATION CONDITIONS	24
9.6 TEST RESULTS	24
<b>10 . MEASUREMENT INSTRUMENTS LIST</b>	<b>25</b>
<b>11 . EUT TEST PHOTO</b>	<b>28</b>
<b>APPENDIX A - RADIATED EMISSION - 9 KHZ TO 30 MHZ</b>	<b>33</b>
<b>APPENDIX B - RADIATED EMISSION - 30 MHZ TO 1000 MHZ</b>	<b>38</b>

**Table of Contents****Page**

<b>APPENDIX C - RADIATED EMISSION - ABOVE 1000 MHZ</b>	<b>41</b>
<b>APPENDIX D - NUMBER OF HOPPING FREQUENCY</b>	<b>60</b>
<b>APPENDIX E - AVERAGE TIME OF OCCUPANCY</b>	<b>62</b>
<b>APPENDIX F - HOPPING CHANNEL SEPARATION</b>	<b>67</b>
<b>APPENDIX G - BANDWIDTH</b>	<b>69</b>
<b>APPENDIX H - MAXIMUM OUTPUT POWER</b>	<b>71</b>
<b>APPENDIX I - CONDUCTED SPURIOUS EMISSION</b>	<b>75</b>
<b>APPENDIX J - DECLARATION FOR BLUETOOTH DEVICE</b>	<b>78</b>

**REPORT ISSUED HISTORY**

Report No.	Version	Description	Issued Date	Note
BTL-FCCP-5-2405H020	R00	Original Report.	Sep. 13, 2024	Invalid
BTL-FCCP-5-2405H020	R01	Revised report to address TCB's comments.	Sep. 25, 2024	Valid

## 1. SUMMARY OF TEST RESULTS

Test procedures according to the technical standard(s):

FCC CFR Title 47, Part 15, Subpart C				
Standard(s) Section	Test Item	Test Result	Judgment	Remark
15.207	AC Power Line Conducted Emissions	APPENDIX A	N/A	-----
15.247(d) 15.205(a) 15.209(a)	Radiated Emission	APPENDIX B APPENDIX C APPENDIX D	PASS	-----
15.247 (a)(1)(iii)	Number of Hopping Frequency	APPENDIX E	PASS	-----
15.247 (a)(1)(iii)	Average Time of Occupancy	APPENDIX F	PASS	-----
15.247(a)(1)	Hopping Channel Separation	APPENDIX G	PASS	-----
15.247(a)(1)	Bandwidth	APPENDIX H	PASS	-----
15.247(a)(1)	Maximum Output Power	APPENDIX I	PASS	-----
15.247(d)	Conducted Spurious Emission	APPENDIX J	PASS	-----
15.203	Antenna Requirement	-----	PASS	Note(2)

**Note:**

- (1) "N/A" denotes test is not applicable in this test report
- (2) The device what use a permanently attached antenna were considered sufficient to comply with the provisions of 15.203.

### 1.1 TEST FACILITY

The test facilities used to collect the test data in this report is at the location of No. 29, Jintang Road, Tangzhen Industry Park, Pudong New Area, Shanghai 201210,China  
 BTL's Registration Number for FCC: 964234  
 BTL's Designation Number for FCC: CN1374

### 1.2 MEASUREMENT UNCERTAINTY

ISO/IEC 17025 requires that an estimate of the measurement uncertainties associated with the emissions test results be included in the report. The measurement uncertainties given below are based on a 95% confidence level (based on a coverage factor (k=2))  
 The BTL measurement uncertainty as below table:

#### A. Radiated emissions test:

Test Site	Measurement Frequency Range	Ant. H / V	U, (dB)
SH-CB02	9 KHz~30 MHz	-	2.72
	30 MHz~200 MHz	V	4.4
	30 MHz~200 MHz	H	3.16
	200 MHz~1,000 MHz	V	4.6
	200 MHz~1,000 MHz	H	4.2
	1GHz ~ 6GHz	-	4.56
	6GHz ~ 18GHz	-	5.14
	18 ~ 26.5 GHz	-	1.68
	26.5~40 GHz		1.71

Note: Unless specifically mentioned, the uncertainty of measurement has not been taken into account to declare the compliance or non-compliance to the specification.

### 1.3 TEST ENVIRONMENT CONDITIONS

Test Item	Temperature	Humidity	Test Voltage	Tested By
Radiated Emissions-9 kHz to 30 MHz	26.1°C	49%	AC 120V/60Hz	Yahya Fang
Radiated Emissions-30 MHz to 1000 MHz	27°C	54%	AC 120V/60Hz	Yahya Fang
Radiated Emissions-Above 1000 MHz	23.8°C~26.1°C	48%~49%	AC 120V/60Hz	Yahya Fang
Number of Hopping Frequency	24.3°C	55%	AC 120V/60Hz	Thacker Tang
Average Time of Occupancy	24.3°C	55%	AC 120V/60Hz	Thacker Tang
Hopping Channel Separation	24.3°C	55%	AC 120V/60Hz	Thacker Tang
Bandwidth	24.3°C	55%	AC 120V/60Hz	Thacker Tang
Maximum Output Power	24.3°C	55%	AC 120V/60Hz	Thacker Tang
Conducted Spurious Emission	24.3°C	55%	AC 120V/60Hz	Thacker Tang



## 2. GENERAL INFORMATION

### 2.1 GENERAL DESCRIPTION OF EUT

Equipment	Smart Module
Brand Name	N/A
Test Model	PSM803
Series Model	N/A
Model Difference(s)	N/A
Software Version	QCS8550_LE.1.0_AP
Hardware Version	PSM803
Power Source	DC Voltage supplied from AC/DC adapter
Power Rating	I/P: 100-240V~50/60Hz 1.5A    O/P: 12.0V---5.0A 60.0W
Operation Frequency	2402 MHz ~ 2480 MHz
Modulation Type	GFSK, $\pi/4$ -DQPSK, 8-DPSK
Bit Rate of Transmitter	1Mbps, 2Mbps, 3Mbps
Max. Output Power	1Mbps: 8.08 dBm (0.0064 W)

Note:

1. For a more detailed features description, please refer to the manufacturer's specifications or the user's manual.
2. Test according to the manufacturer's declared power.

## 2. Channel List:

Channel	Frequency (MHz)	Channel	Frequency (MHz)	Channel	Frequency (MHz)
00	2402	27	2429	54	2456
01	2403	28	2430	55	2457
02	2404	29	2431	56	2458
03	2405	30	2432	57	2459
04	2406	31	2433	58	2460
05	2407	32	2434	59	2461
06	2408	33	2435	60	2462
07	2409	34	2436	61	2463
08	2410	35	2437	62	2464
09	2411	36	2438	63	2465
10	2412	37	2439	64	2466
11	2413	38	2440	65	2467
12	2414	39	2441	66	2468
13	2415	40	2442	67	2469
14	2416	41	2443	68	2470
15	2417	42	2444	69	2471
16	2418	43	2445	70	2472
17	2419	44	2446	71	2473
18	2420	45	2447	72	2474
19	2421	46	2448	73	2475
20	2422	47	2449	74	2476
21	2423	48	2450	75	2477
22	2424	49	2451	76	2478
23	2425	50	2452	77	2479
24	2426	51	2453	78	2480
25	2427	52	2454		
26	2428	53	2455		

## 3. Table for Filed Antenna:

Ant.	Brand	Model Name	Antenna Type	Connector	Gain (dBi)
1	N/A	N/A	External Antenna	R-SMA	5.82

## Note:

The antenna gain is provided by the manufacturer.

## 2.2 DESCRIPTION OF TEST MODES

The test system was pre-tested based on the consideration of all possible combinations of EUT operation mode.

Pretest Mode	Description
Mode 1	TX Mode_1Mbps Channel 00/39/78
Mode 2	TX Mode_2Mbps Channel 00/39/78
Mode 3	TX Mode_3Mbps Channel 00/39/78

Following mode(s) was (were) found to be the worst case(s) and selected for the final test.

<b>Radiated emissions test - Below 1GHz</b>	
Final Test Mode	Description
Mode 1	TX Mode_1Mbps Channel 00

<b>Radiated emissions test - Above 1GHz</b>	
Final Test Mode	Description
Mode 1	TX Mode_1Mbps Channel 00/39/78
Mode 3	TX Mode_3Mbps Channel 00/39/78

<b>Maximum Output Power</b>	
Final Test Mode	Description
Mode 1	TX Mode_1Mbps Channel 00/39/78
Mode 2	TX Mode_2Mbps Channel 00/39/78
Mode 3	TX Mode_3Mbps Channel 00/39/78

<b>Other Conducted test</b>	
Final Test Mode	Description
Mode 1	TX Mode_1Mbps Channel 00/39/78
Mode 3	TX Mode_3Mbps Channel 00/39/78

**Note:**

- (1) The measurements for Output Power were tested with DH1/3/5 during 1Mbps, 2Mbps and 3Mbps, the worst case were 1Mbps (DH5) and 3Mbps (DH5), only worst case were documented for other test items except Average Time of Occupancy.
- (2) For radiated emission above 1 GHz test, the spurious points of 1GHz~26.5GHz have been pre-tested and in this report only recorded the worst case. The remaining spurious points are all below the limit value of 20dB.
- (3) This product has the mode of BT AFH, which was considered during testing. 800/20/X(X = 2 of DH1, X = 4 of DH3 or X = 6 of DH5) with 20, 10 or 6.67 hops per second in a channel, and then multiply 0.4\*20 (20 # of hopping). But this mode is not the worst case mode as duration of the packet is same, and this report only shows the worst case mode.
- (4) For Radiated spurious emissions below 1 GHz test, the 1Mbps Channel 00 is found to be the worst case and recorded.

### 2.3 PARAMETERS OF TEST SOFTWARE

During testing, channel & power controlling software provided by the customer was used to control the operating channel as well as the output power level.

Test Software Version	QRCT		
Frequency (MHz)	2402	2441	2480
1Mbps	Default	Default	Default
2Mbps	Default	Default	Default
3Mbps	Default	Default	Default

## 2.4 BLOCK DIAGRAM SHOWING THE CONFIGURATION OF SYSTEM TESTED

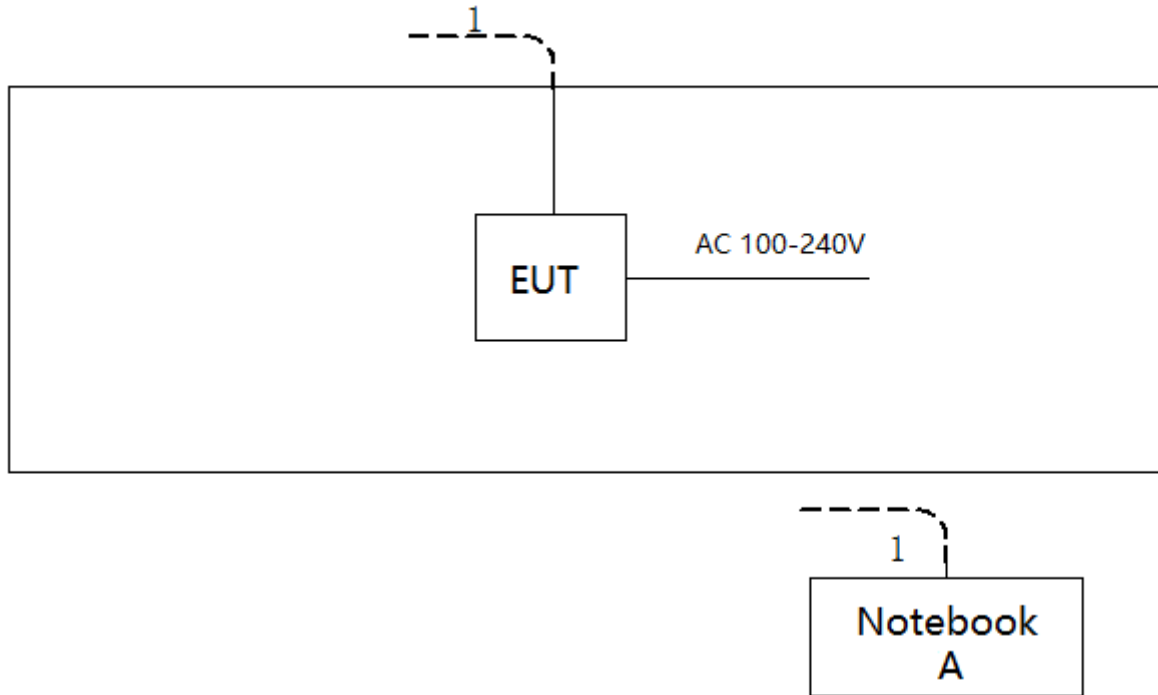

## 2.5 SUPPORT UNITS

Item	Equipment	Brand	Model No.	Series No.
A	Notebook	Dell	Inspiron 15-7559	N/A

Item	Cable Type	Shielded Type	Ferrite Core	Length
1	USB Cable	NO	NO	10m

### 3. RADIATED EMISSIONS

#### 3.1 LIMIT

In case the emission fall within the restricted band specified on 15.205(a), then the 15.209(a) limit in the table below has to be followed.

#### LIMITS OF RADIATED EMISSION MEASUREMENT (9 kHz-1000 MHz)

Frequency (MHz)	Field Strength (microvolts/meter)	Measurement Distance (meters)
0.009-0.490	2400/F(kHz)	300
0.490-1.705	24000/F(kHz)	30
1.705-30.0	30	30
30-88	100	3
88-216	150	3
216-960	200	3
Above 960	500	3

#### LIMITS OF RADIATED EMISSION MEASUREMENT (Above 1000 MHz)

Frequency (MHz)	(dBuV/m at 3 m)	
	Peak	Average
Above 1000	74	54

Note:

- (1) The limit for radiated test was performed according to FCC CFR Title 47, Part 15, Subpart C.
- (2) The tighter limit applies at the band edges.
- (3) Emission level (dBuV/m)=20log Emission level (uV/m).

### 3.2 TEST PROCEDURE

- a. The measuring distance of 3 m shall be used for measurements. The EUT was placed on the top of a rotating table 0.8 meter above the ground at a 3 meter semi-anechoic chamber. The table was rotated 360 degrees to determine the position of the highest radiation.(below 1 GHz)
- b. The measuring distance of 3 m shall be used for measurements. The EUT was placed on the top of a rotating table 1.5 meter above the ground at a 3 meter semi-anechoic chamber. The table was rotated 360 degrees to determine the position of the highest radiation.(above 1 GHz)
- c. The height of the equipment or of the substitution antenna shall be 0.8m or 1.5m; the height of the test antenna shall vary between 1 m to 4 m. Both horizontal and vertical polarizations of the antenna are set to make the measurement.
- d. For each suspected emission, the EUT was arranged to its worst case and then the antenna was tuned to heights find the maximum reading (used Bore sight function).
- e. The receiver system was set to peak and average detect function and specified bandwidth with maximum hold mode when the test frequency is above 1 GHz.
- f. The initial step in collecting radiated emission data is a receiver peak detector mode pre-scanning the measurement frequency range. Significant peaks are then marked and then Quasi Peak detector mode re-measured.
- g. All readings are Peak unless otherwise stated QP in column of Note. Peak denotes that the Peak reading compliance with the QP Limits and then QP Mode measurement didn't perform.  
(below 1 GHz)
- h. All readings are Peak Mode value unless otherwise stated AVG in column of Note. If the Peak Mode Measured value compliance with the Peak Limits and lower than AVG Limits, the EUT shall be deemed to meet both Peak & AVG Limits and then only Peak Mode was measured, but AVG Mode didn't perform. (above 1 GHz)
- i. For the actual test configuration, please refer to the related Item –EUT Test Photos.

The following table is the setting of the receiver:

Spectrum Parameters	Setting
Start ~ Stop Frequency	9 kHz~150 kHz for RBW 200 Hz
Start ~ Stop Frequency	0.15 MHz~30 MHz for RBW 9 kHz
Start ~ Stop Frequency	30 MHz~1000 MHz for RBW 100 kHz

Spectrum Parameters	Setting
Start Frequency	1000 MHz
Stop Frequency	10th carrier harmonic
RBW / VBW (Emission in restricted band)	1 MHz / 3 MHz for PK value 1 MHz / 1/T Hz for AVG value

Spectrum Parameters	Setting
Start ~ Stop Frequency	9 kHz~90 kHz for PK/AVG detector
Start ~ Stop Frequency	90 kHz~110 kHz for QP detector
Start ~ Stop Frequency	110 kHz~490 kHz for PK/AVG detector
Start ~ Stop Frequency	490 kHz~30 MHz for QP detector
Start ~ Stop Frequency	30 MHz~1000 MHz for QP detector
Start ~ Stop Frequency	1 GHz~26.5 GHz for PK/AVG detector

### 3.3 DEVIATION FROM TEST STANDARD

No deviation.

### 3.4 TEST SETUP

#### 9 kHz to 30 MHz

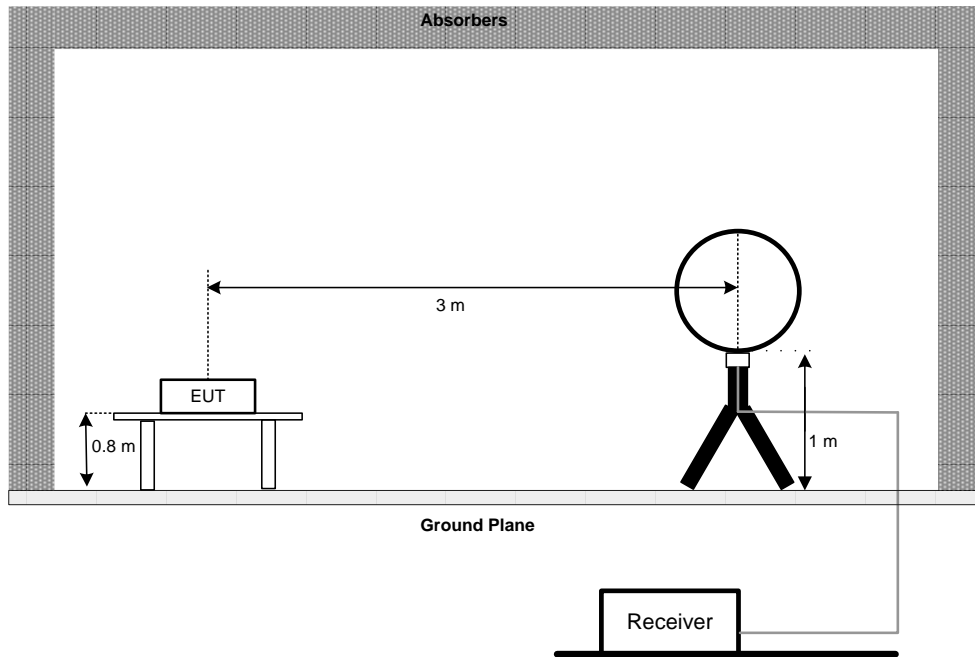

#### 30 MHz to 1 GHz

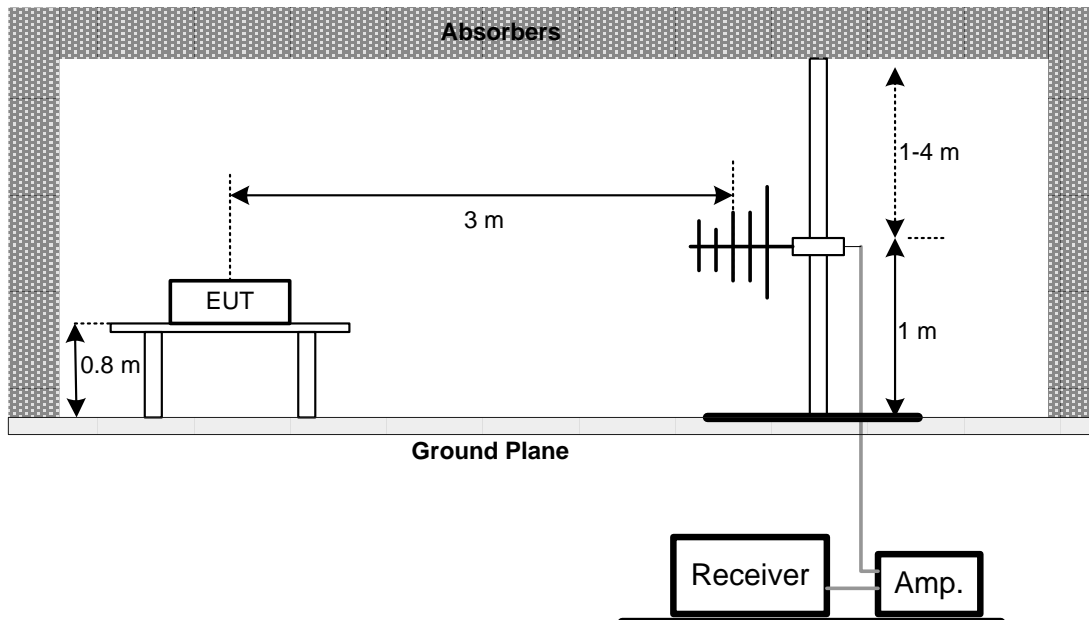



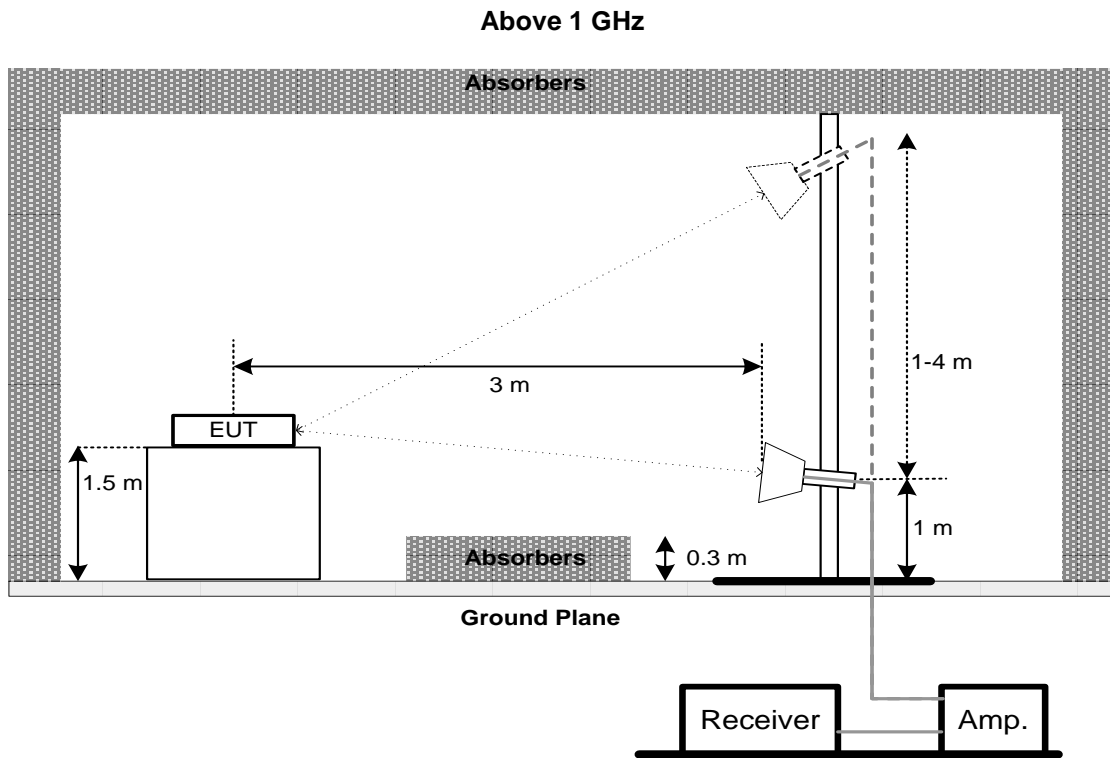

**3.5 EUT OPERATING CONDITIONS**

The EUT was programmed to be in continuously transmitting mode.

**3.6 TEST RESULTS - 9 kHz TO 30 MHz**

Please refer to the APPENDIX A.

Remark:

- (1) Distance extrapolation factor =  $40 \log(\text{specific distance} / \text{test distance})$  (dB).
- (2) Limit line = specific limits (dBuV) + distance extrapolation factor.

**3.7 TEST RESULTS - 30 MHz TO 1000 MHz**

Please refer to the APPENDIX B.

**3.8 TEST RESULTS - ABOVE 1000 MHz**

Please refer to the APPENDIX C.

Remark:

- (1) No limit: This is fundamental signal, the judgment is not applicable.  
For fundamental signal judgment was referred to Peak output test.

#### 4. NUMBER OF HOPPING FREQUENCY

##### 4.1 LIMIT

Section	Test Item	Limit
FCC 15.247(a)(1)(iii)	Number of Hopping Frequency	15

##### 4.2 TEST PROCEDURE

- The EUT was directly connected to the spectrum analyzer and antenna output port as show in the block diagram below.
- The following table is the setting of the spectrum analyzer:

Spectrum Parameters	Setting
Span Frequency	> Operating Frequency Range
RBW	100 kHz
VBW	100 kHz
Detector	Peak
Trace	Max Hold
Sweep Time	Auto

##### 4.3 DEVIATION FROM STANDARD

No deviation.

##### 4.4 TEST SETUP



##### 4.5 EUT OPERATION CONDITIONS

The EUT was programmed to be in continuously transmitting mode.

##### 4.6 TEST RESULTS

Please refer to the APPENDIX D.

## 5. AVERAGE TIME OF OCCUPANCY

### 5.1 LIMIT

Section	Test Item	Limit
FCC 15.247(a)(1)(iii)	Average Time of Occupancy	0.4sec

### 5.2 TEST PROCEDURE

- Set the EUT for DH1, DH3 and DH5 packet transmitting.
- Measure the maximum time duration of one single pulse.
- DH1 Packet permit maximum  $1600 / 79 / 2 = 10.12$  hops per second in each channel (1 time slot TX, 1 time slot RX). So, the dwell time is the time duration of the pulse times  $10.12 \times 31.6 = 320$  within 31.6 seconds.
- DH3 Packet permit maximum  $1600 / 79 / 4 = 5.06$  hops per second in each channel (3 time slots TX, 1 time slot RX). So, the dwell time is the time duration of the pulse times  $5.06 \times 31.6 = 160$  within 31.6 seconds.
- DH5 Packet permit maximum  $1600 / 79 / 6 = 3.37$  hops per second in each channel (5 time slots TX, 1 time slot RX). So, the dwell time is the time duration of the pulse times  $3.37 \times 31.6 = 106.6$  within 31.6 seconds.
- The EUT was directly connected to the spectrum analyzer and antenna output port as show in the block diagram below.
- The following table is the setting of the spectrum analyzer:

Spectrum Parameters	Setting
Span Frequency	0 MHz
RBW	1 MHz
VBW	1 MHz
Detector	Peak
Trace	Max Hold
Sweep Time	As necessary to capture the entire dwell time per hopping channel

### 5.3 DEVIATION FROM STANDARD

No deviation.

### 5.4 TEST SETUP



### 5.5 EUT OPERATION CONDITIONS

The EUT was programmed to be in continuously transmitting mode.

### 5.6 TEST RESULTS

Please refer to the APPENDIX E.

## 6. HOPPING CHANNEL SEPARATION

### 6.1 LIMIT

Frequency hopping systems operating in the 2400-2483.5 MHz band may have hopping channel carrier frequencies that are separated by 25 kHz or two-thirds of the 20 dB bandwidth of the hopping channel, whichever is greater, provided the systems operate with an output power no greater than 125 mW.

### 6.2 TEST PROCEDURE

- a. The EUT was directly connected to the spectrum analyzer and antenna output port as show in the block diagram below.
- b. The following table is the setting of the spectrum analyzer:

Spectrum Parameters	Setting
Span Frequency	Wide enough to capture the peaks of two adjacent channels
RBW	30 kHz
VBW	100 kHz
Detector	Peak
Trace	Max Hold
Sweep Time	Auto

### 6.3 DEVIATION FROM STANDARD

No deviation.

### 6.4 TEST SETUP



### 6.5 EUT OPERATION CONDITIONS

The EUT was programmed to be in continuously transmitting mode.

### 6.6 TEST RESULTS

Please refer to the APPENDIX F.

## 7. BANDWIDTH

### 7.1 LIMIT

Section	Test Item
FCC 15.247(a)(1)	Bandwidth

### 7.2 TEST PROCEDURE

- The EUT was directly connected to the spectrum analyzer and antenna output port as show in the block diagram below.
- The following table is the setting of the spectrum analyzer:

Spectrum Parameters	Setting
Span Frequency	> Measurement Bandwidth
RBW	30 kHz
VBW	100 kHz
Detector	Peak
Trace	Max Hold
Sweep Time	Auto

### 7.3 DEVIATION FROM STANDARD

No deviation.

### 7.4 TEST SETUP



### 7.5 EUT OPERATION CONDITIONS

The EUT was programmed to be in continuously transmitting mode.

### 7.6 TEST RESULTS

Please refer to the APPENDIX G.

## 8. MAXIMUM OUTPUT POWER

### 8.1 LIMIT

Section	Test Item	Limit
FCC 15.247(a)(1)	Maximum Output Power	0.1250 Watt or 20.97 dBm

Note: Frequency hopping systems operating in the 2400-2483.5 MHz band may have hopping channel carrier frequencies that are separated by 25 kHz or two-thirds of the 20 dB bandwidth of the hopping channel, whichever is greater, provided the systems operate with an output power no greater than 125 mW.

### 8.2 TEST PROCEDURE

- The EUT was directly connected to the spectrum analyzer and antenna output port as show in the block diagram below.
- The following table is the setting of the spectrum analyzer:

Spectrum Parameters	Setting
Span Frequency	Approximately five times the 20 dB bandwidth, centered on a hopping channel.
RBW	3 MHz
VBW	3 MHz
Detector	Peak
Trace	Max Hold
Sweep Time	Auto

### 8.3 DEVIATION FROM STANDARD

No deviation.

### 8.4 TEST SETUP

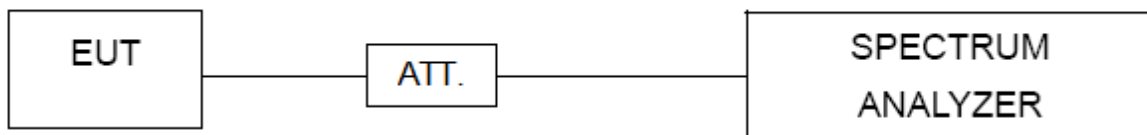

### 8.5 EUT OPERATION CONDITIONS

The EUT was programmed to be in continuously transmitting mode.

### 8.6 TEST RESULTS

Please refer to the APPENDIX H.

## 9. CONDUCTED SPURIOUS EMISSION

### 9.1 LIMIT

In any 100 kHz bandwidth outside the frequency band in which the spread spectrum or digitally modulated intentional radiator is operating, the radio frequency power that is produced by the intentional radiator shall be at least 20 dB below that in the 100 kHz bandwidth within the band that contains the highest level of the desired power, based on either an RF conducted or a radiated measurement, provided the transmitter demonstrates compliance with the peak Output Power limits. If the transmitter complies with the Output Power limits based on the use of RMS averaging over a time interval, as permitted under paragraph (b)(3) of this section, the attenuation required under this paragraph shall be 30 dB instead of 20 dB. Attenuation below the general limits specified in Section 15.209(a) is not required.

### 9.2 TEST PROCEDURE

- a. The EUT was directly connected to the spectrum analyzer and antenna output port as show in the block diagram below.
- b. The following table is the setting of the spectrum analyzer:

Spectrum Parameters	Setting
Start Frequency	30 MHz
Stop Frequency	26.5 GHz
RBW	100 kHz
VBW	100 kHz
Detector	Peak
Trace	Max Hold
Sweep Time	Auto

### 9.3 DEVIATION FROM STANDARD

No deviation.

### 9.4 TEST SETUP

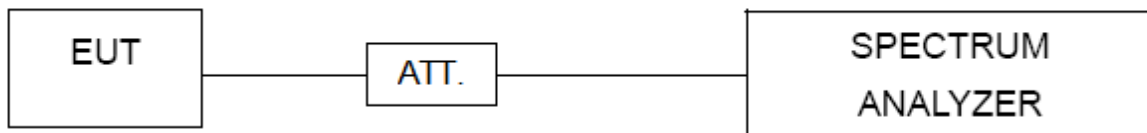

### 9.5 EUT OPERATION CONDITIONS

The EUT was programmed to be in continuously transmitting mode.

### 9.6 TEST RESULTS

Please refer to the APPENDIX I.



**10. MEASUREMENT INSTRUMENTS LIST**

Radiated Emissions - 9 kHz to 30 MHz					
Item	Kind of Equipment	Manufacturer	Type No.	Serial No.	Calibrated until
1	Loop Antenna	EMCI	EMCI LPA600	275	Mar. 12, 2025
2	MXE EMI Receiver	Keysight	N9038A	MY56400088	Feb. 2, 2025
3	Measurement Software	Farad	EZ-EMC Ver.NB-03A1	N/A	N/A
4	Wideband Radio Communication Test	R&S	CMW500	129246	Jul. 12, 2025
5	Pre-Amplifier	emci	EMC9135	980401	Feb. 2, 2025

Radiated Emissions - 30 MHz to 1 GHz					
Item	Kind of Equipment	Manufacturer	Type No.	Serial No.	Calibrated until
1	Antenna	emci	VULB 9168	1467	Mar. 12, 2025
2	Pre-Amplifier	emci	EMC9135	980401	Feb. 2, 2025
3	MXE EMI Receiver	Keysight	N9038A	MY56400088	Feb. 2, 2025
4	Test Cable	emci	EMC104-SM-SM-7 000	181020	May. 20, 2025
5	Test Cable	emci	RWP50-4.6A-SMS M-1M	20200928 002	May. 20, 2025
6	Test Cable	emci	EMC104-SM-SM-2 500	170618	May. 20, 2025
7	Measurement Software	Farad	EZ-EMC Ver.NB-03A1	N/A	N/A
8	Wideband Radio Communication Test	R&S	CMW500	129246	Jul. 12, 2025

Radiated Emissions - Above 1 GHz					
Item	Kind of Equipment	Manufacturer	Type No.	Serial No.	Calibrated until
1	Double-Ridged Waveguide Horn Antenna	ETS-Lindgren	BBHA 9120D	9120D-1817	Mar.12, 2025
2	Pre-Amplifier	emci	EMC051845SE	980725	Jul. 13, 2024 Jul. 12, 2025
3	EXA Spectrum Analyzer	Keysight	N9010A	MY56480579	Feb. 2, 2025
4	Test Cable	emci	EMC104-SM-SM-7000	181020	May 20, 2025
5	Test Cable	emci	RWP50-4.6A-SMS M-1M	20200928 002	May 20, 2025
6	Test Cable	emci	EMC104-SM-SM-2500	170618	May 20, 2025
7	Measurement Software	Farad	EZ-EMC Ver.NB-03A1	N/A	N/A
8	Wideband Radio Communication Test	R&S	CMW500	129246	Jul. 12, 2025
9	Antenna	Schwarzbeck	BBHA9170	9170-651	Mar. 15, 2025
10	Pre-Amplifier	EMC INSTRUMENT	EMC184045B	980265	Feb. 2, 2025
11	Test Cable	emci	100% S-Parameter Recorded	F02-150819-039	Oct. 21, 2024
12	Test Cable	emci	EMC104-SM-SM-2500	170616	Oct. 21, 2024
13	Test Cable	emci	EMC104-SM-SM-2500	170652	Oct. 21, 2024
14	EXA Spectrum Analyzer	Keysight	N9010A	MY56480559	Feb. 2, 2025

Number of Hopping Frequency					
Item	Kind of Equipment	Manufacturer	Type No.	Serial No.	Calibrated until
1	EXA Spectrum Analyzer	Keysight	N9010A	MY56480545	Jul. 13, 2024 Jul. 12, 2025
2	BTL Conducted Test	BTL	20231123	N/A	N/A

Average Time of Occupancy					
Item	Kind of Equipment	Manufacturer	Type No.	Serial No.	Calibrated until
1	EXA Spectrum Analyzer	Keysight	N9010A	MY56480545	Jul. 13, 2024 Jul. 12, 2025
2	BTL Conducted Test	BTL	20231123	N/A	N/A

Hopping Channel Separation Measurement					
Item	Kind of Equipment	Manufacturer	Type No.	Serial No.	Calibrated until
1	EXA Spectrum Analyzer	Keysight	N9010A	MY56480545	Jul. 13, 2024 Jul. 12, 2025
2	BTL Conducted Test	BTL	20231123	N/A	N/A

Bandwidth					
Item	Kind of Equipment	Manufacturer	Type No.	Serial No.	Calibrated until
1	EXA Spectrum Analyzer	Keysight	N9010A	MY56480545	Jul. 13, 2024 Jul. 12, 2025
2	BTL Conducted Test	BTL	20231123	N/A	N/A

Maximum Output Power					
Item	Kind of Equipment	Manufacturer	Type No.	Serial No.	Calibrated until
1	EXA Spectrum Analyzer	Keysight	N9010A	MY56480545	Jul. 13, 2024 Jul. 12, 2025
2	BTL Conducted Test	BTL	20231123	N/A	N/A

Antenna Conducted Spurious Emission					
Item	Kind of Equipment	Manufacturer	Type No.	Serial No.	Calibrated until
1	EXA Spectrum Analyzer	Keysight	N9010A	MY56480545	Jul. 13, 2024 Jul. 12, 2025
2	BTL Conducted Test	BTL	20231123	N/A	N/A

Remark: "N/A" denotes no model name, serial no. or calibration specified.

All calibration period of equipment list is one year.

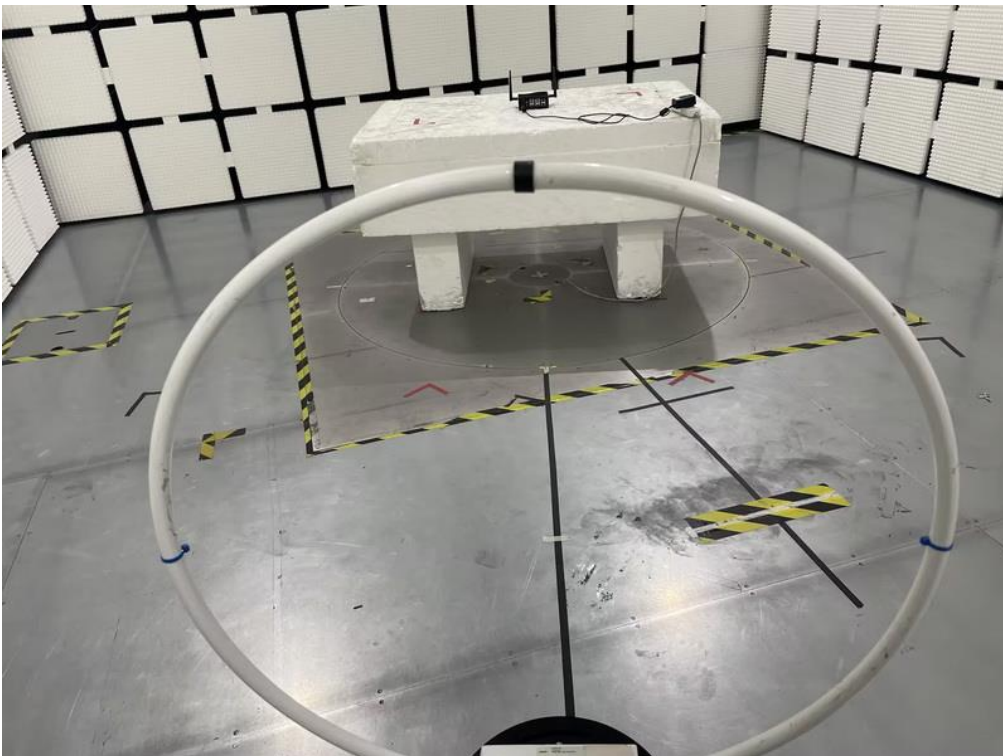
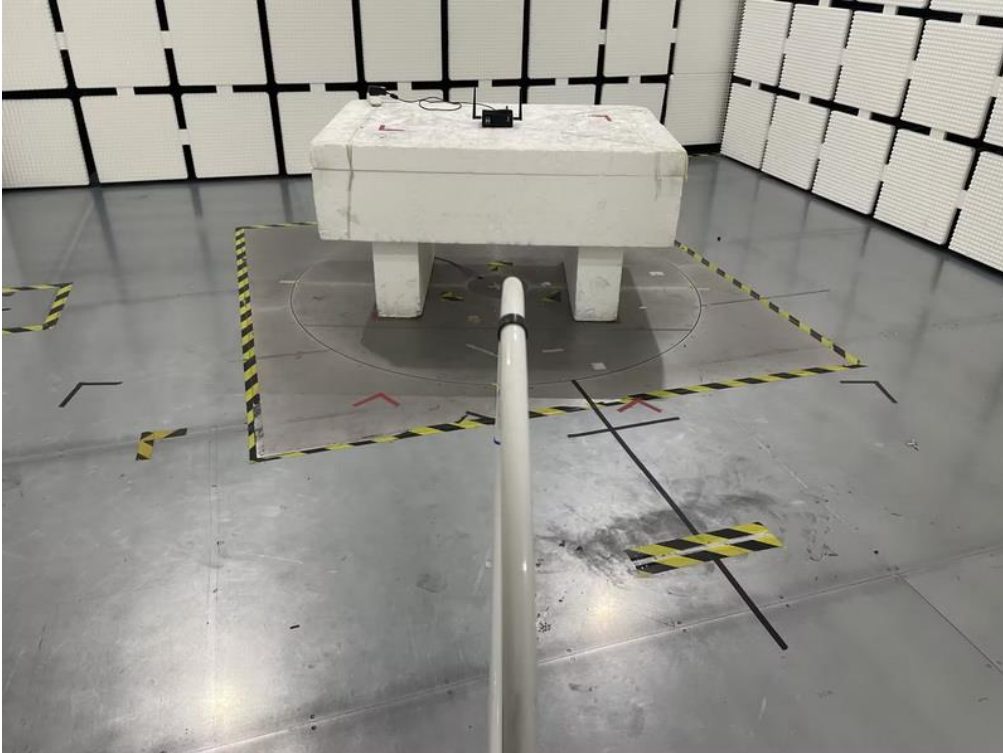
**11. EUT TEST PHOTO****Radiated Emissions Test Photos****9 kHz to 30 MHz**

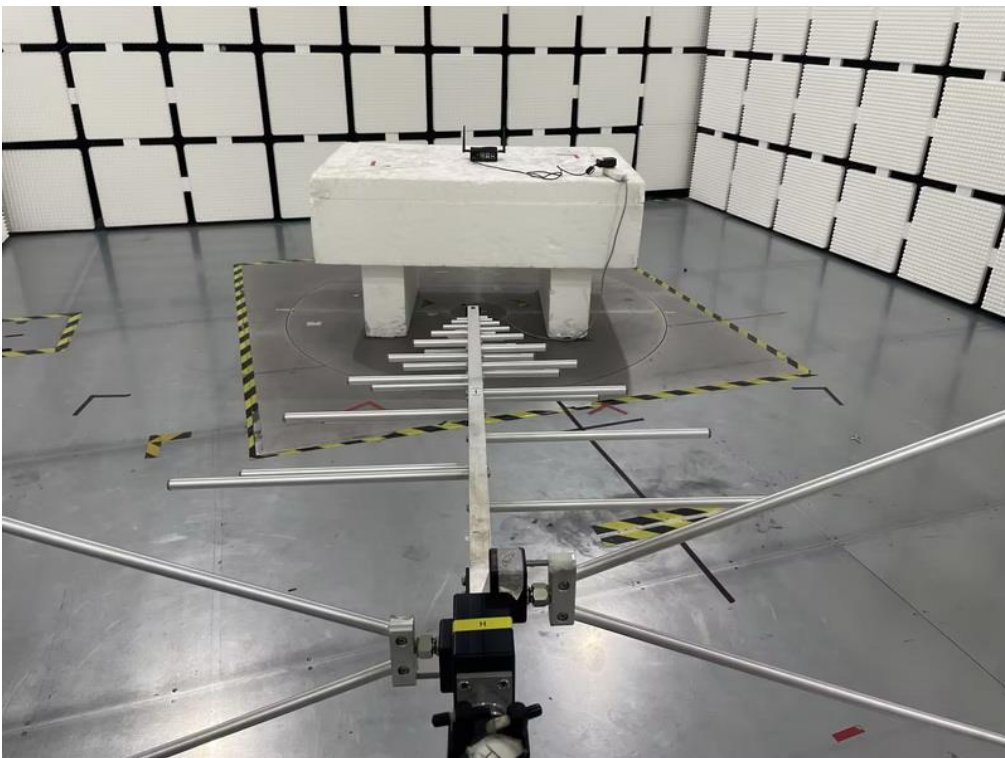
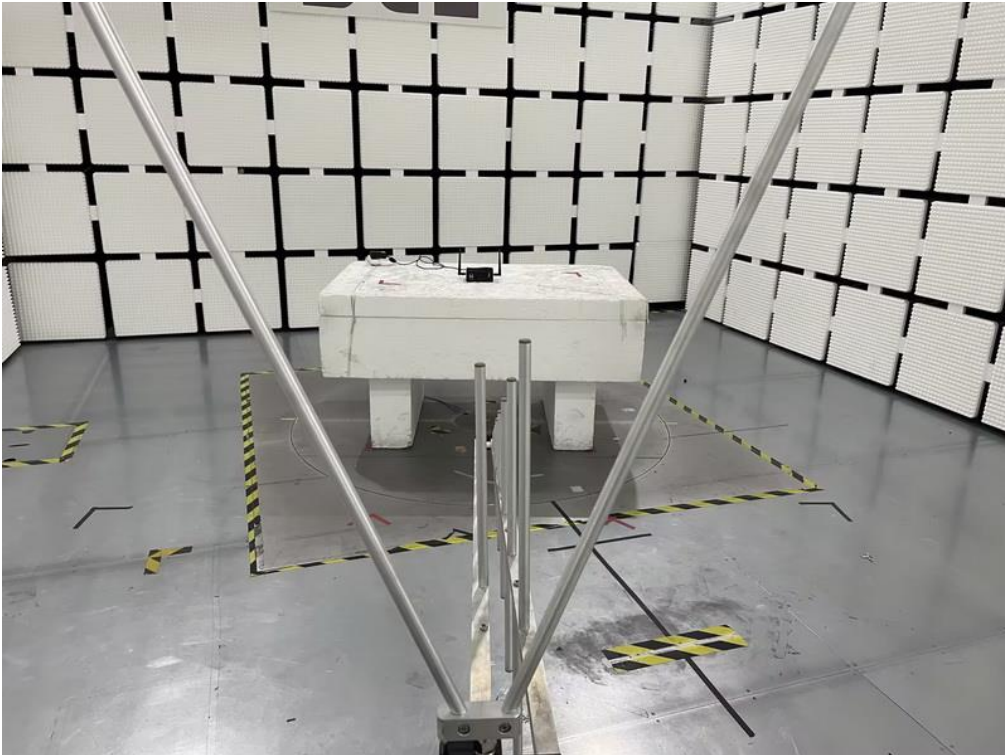
**Radiated Emissions Test Photos****30 MHz to 1000 MHz**

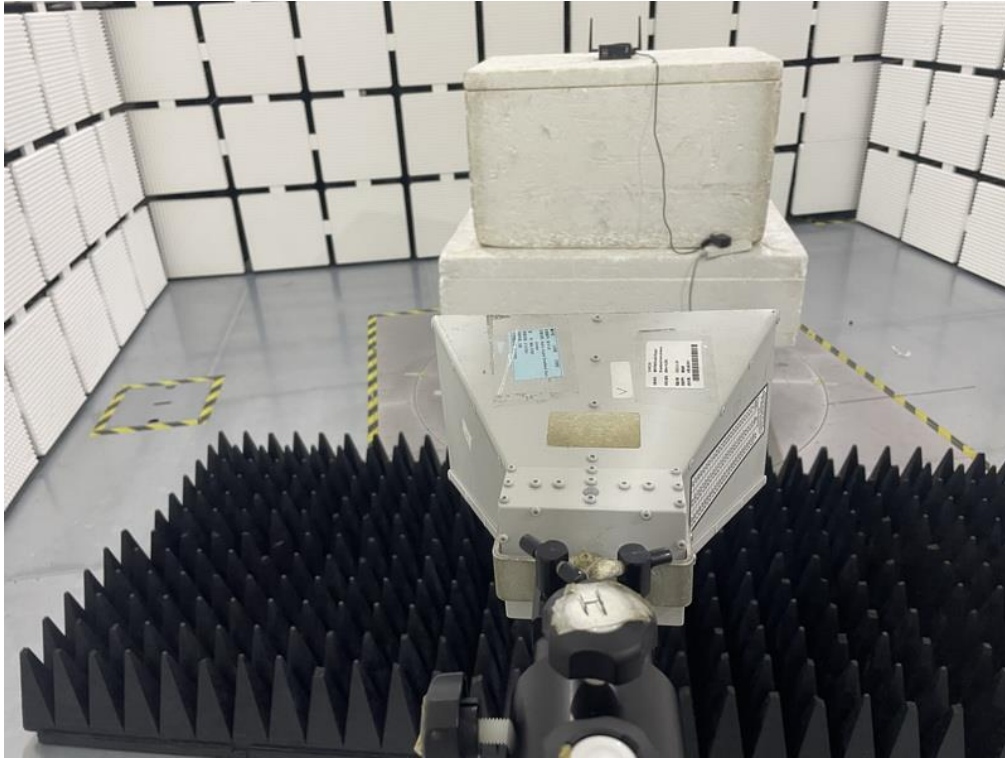
**Radiated Emissions Test Photos****Above 1 GHz**

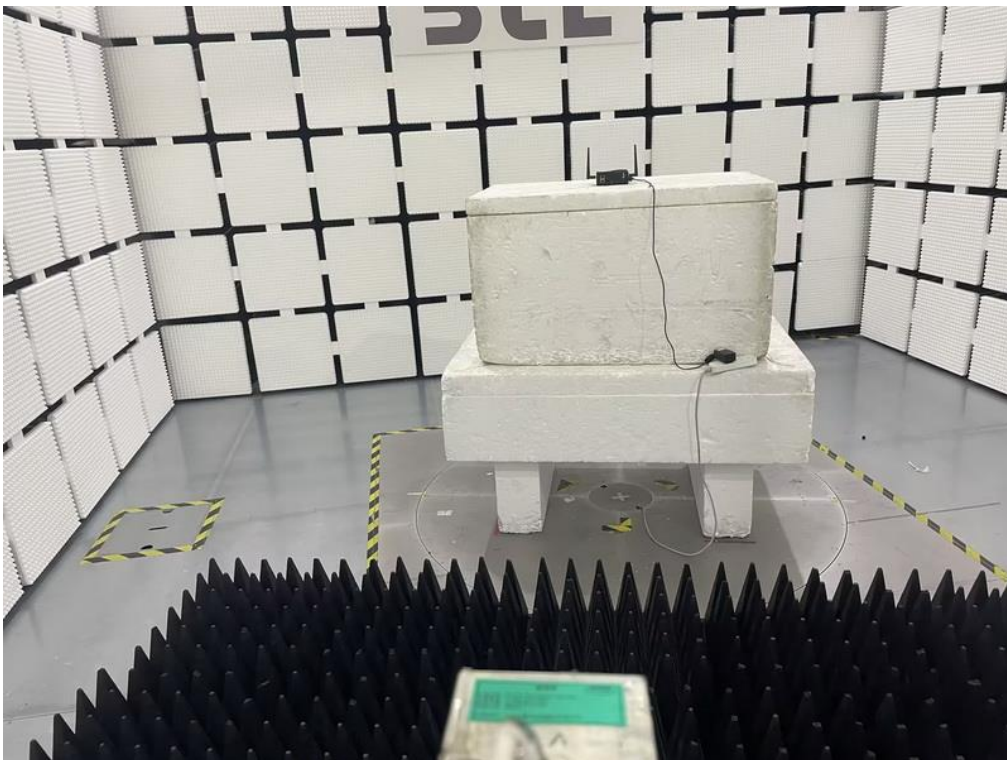
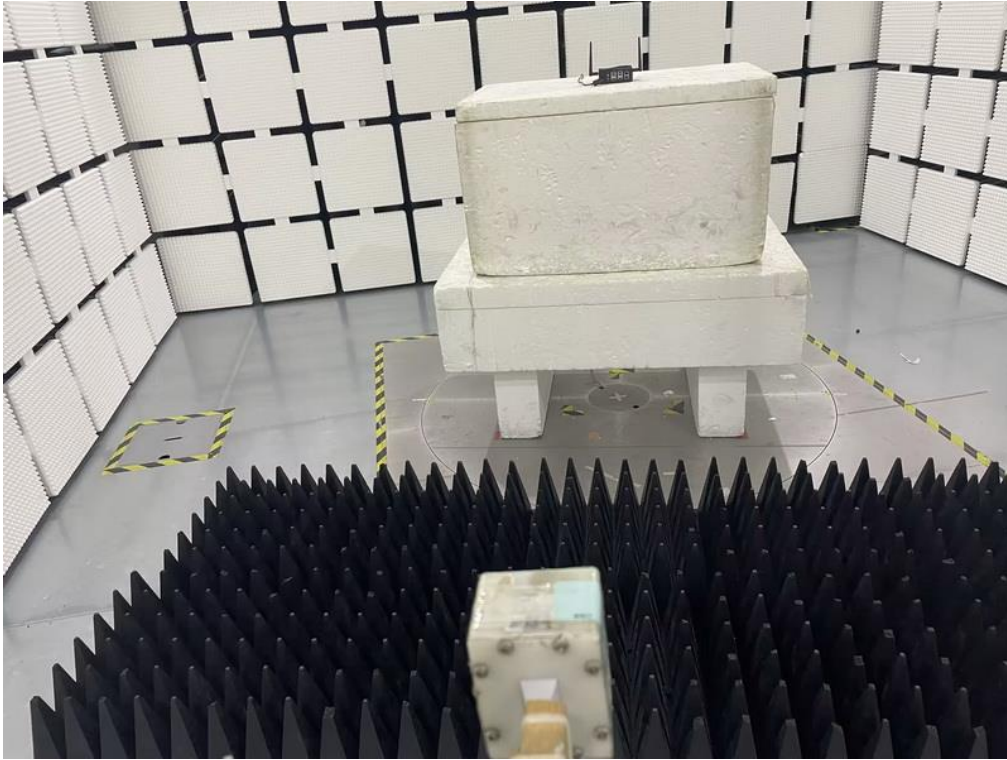
**Radiated Emissions Test Photos****Above 18 GHz**

**Close-up photo**



**APPENDIX A - RADIATED EMISSION - 9 KHZ TO 30 MHZ**

Test Mode	TX Mode_1Mbps Channel 00	Polarization	Ant 0°
-----------	--------------------------	--------------	--------

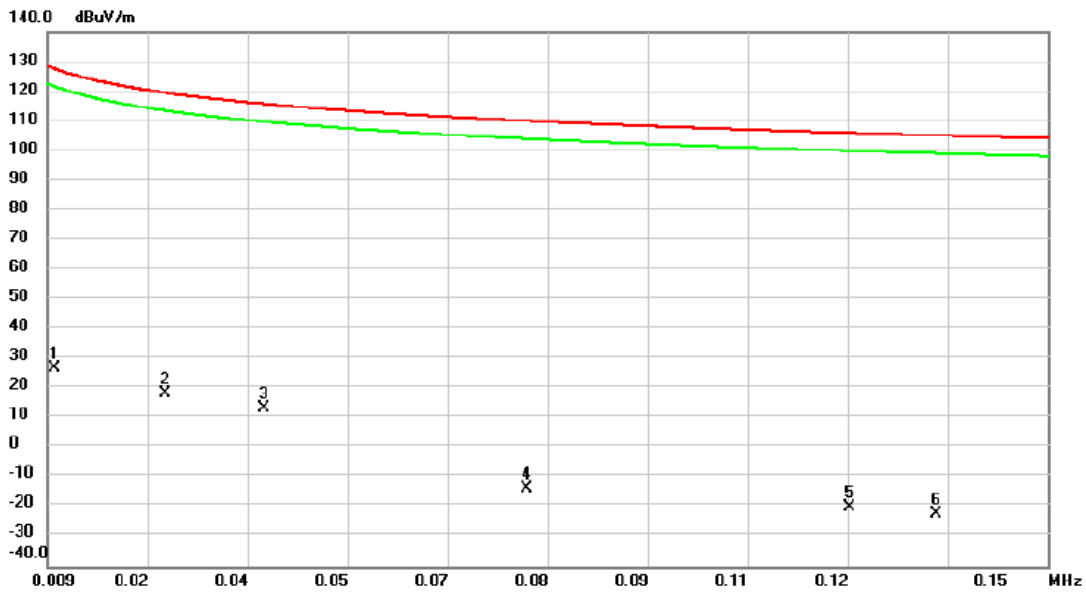

No.	Mk.	Freq.	Reading Level	Correct Factor	Measurement	Limit	Margin	Antenna Height	Table Degree	Comment
		MHz	dBuV	dB	dBuV/m	dBuV/m	dB	cm	degree	
1	*	0.0100	10.56	16.42	26.98	127.60	-100.62			peak
2		0.0256	17.21	0.85	18.06	119.44	-101.38			peak
3		0.0396	19.69	-6.57	13.12	115.65	-102.53			peak
4		0.0765	3.28	-17.03	-13.75	109.93	-123.68			peak
5		0.1220	4.68	-24.86	-20.18	105.88	-126.06			peak
6		0.1343	3.85	-26.05	-22.20	105.05	-127.25			peak

**REMARKS:**

- (1) Measurement Value = Reading Level + Correct Factor.
- (2) Margin Level = Measurement Value - Limit Value.

Test Mode	TX Mode_1Mbps Channel 00	Polarization	Ant 0°
-----------	--------------------------	--------------	--------

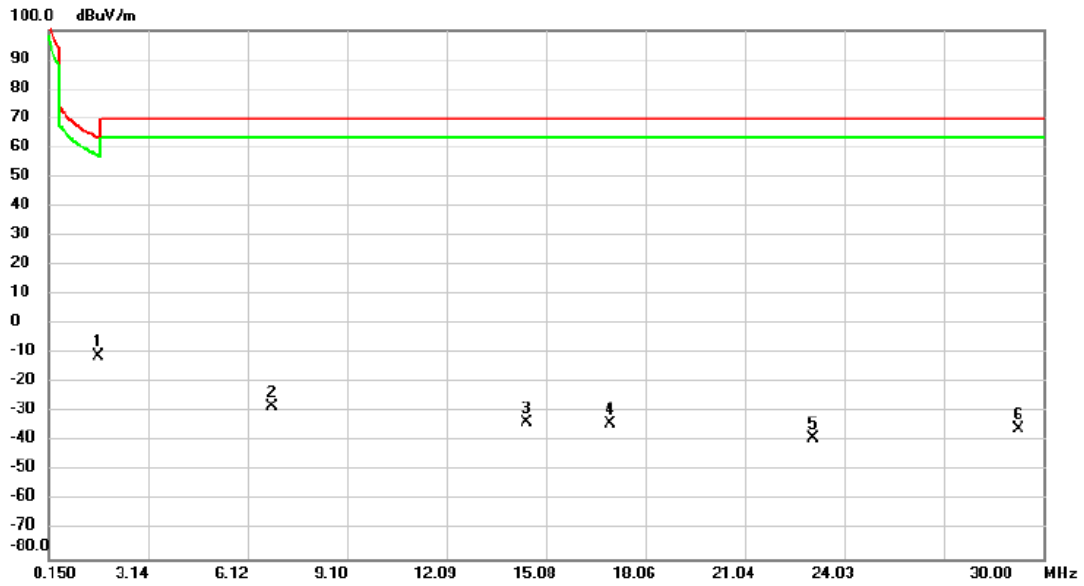

No.	Mk.	Freq. MHz	Reading Level dBuV	Correct Factor dB	Measure- ment dBuV/m	Limit dBuV/m	Margin dB	Detector	Antenna Height cm	Table Degree degree	Comment
1	*	1.6425	38.45	-49.41	-10.96	63.29	-74.25	peak			
2		6.8662	24.98	-52.79	-27.81	69.54	-97.35	peak			
3		14.4780	20.43	-53.70	-33.27	69.54	-102.81	peak			
4		17.0153	20.71	-54.53	-33.82	69.54	-103.36	peak			
5		23.0748	17.22	-56.13	-38.91	69.54	-108.45	peak			
6		29.2538	18.54	-54.24	-35.70	69.54	-105.24	peak			

**REMARKS:**

- (1) Measurement Value = Reading Level + Correct Factor.
- (2) Margin Level = Measurement Value - Limit Value.

Test Mode	TX Mode_1Mbps Channel 00	Polarization	Ant 90°
-----------	--------------------------	--------------	---------



No.	Mk.	Freq.	Reading Level	Correct Factor	Measurement	Limit	Margin	Antenna Height	Table Degree	
		MHz	dBuV	dB	dBuV/m	dBuV/m	dB	cm	degree	Comment
1		0.1500	23.79	-27.51	-3.72	104.09	-107.81			peak
2	*	1.7171	31.68	-49.60	-17.92	69.54	-87.46			peak
3		12.2840	23.78	-53.48	-29.70	69.54	-99.24			peak
4		20.0450	22.50	-55.25	-32.75	69.54	-102.29			peak
5		26.1792	24.36	-57.37	-33.01	69.54	-102.55			peak
6		27.6866	23.29	-56.54	-33.25	69.54	-102.79			peak

**REMARKS:**

- (1) Measurement Value = Reading Level + Correct Factor.
- (2) Margin Level = Measurement Value - Limit Value.

Test Mode	TX Mode_1Mbps Channel 00	Polarization	Ant 90°
-----------	--------------------------	--------------	---------

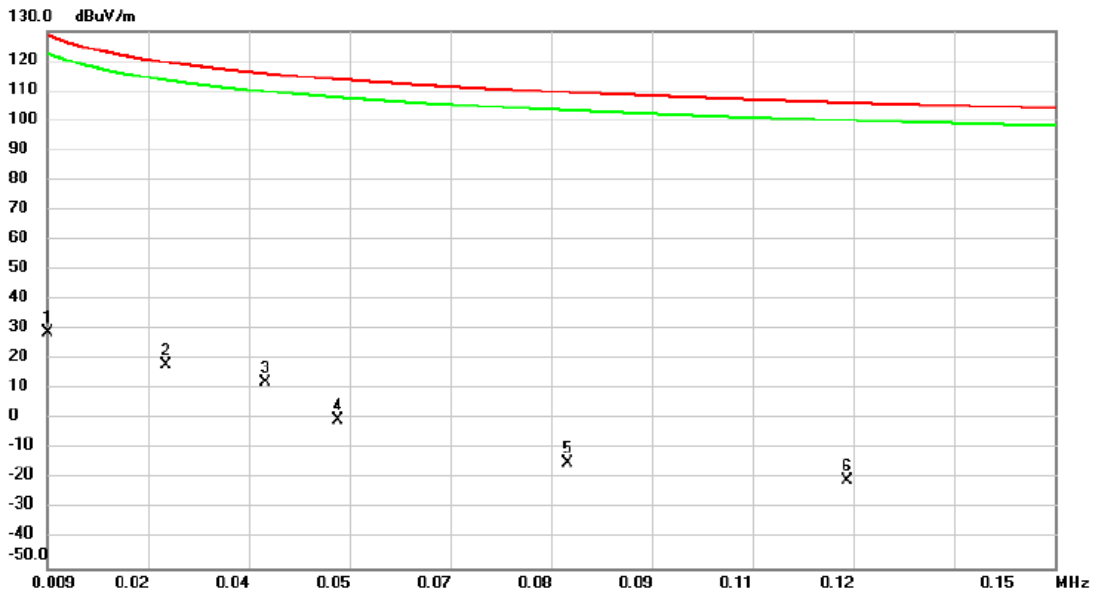

No.	Mk.	Freq.	Reading Level	Correct Factor	Measurement	Limit	Margin	Antenna Height	Table Degree	
		MHz	dBuV	dB	dBuV/m	dBuV/m	dB	cm	degree	Comment
1	*	0.0090	10.27	18.49	28.76	128.52	-99.76			peak
2		0.0256	17.17	0.85	18.02	119.44	-101.42			peak
3		0.0396	18.84	-6.57	12.27	115.65	-103.38			peak
4		0.0497	9.72	-9.81	-0.09	113.68	-113.77			peak
5		0.0818	3.84	-18.35	-14.51	109.35	-123.86			peak
6		0.1210	4.22	-24.77	-20.55	105.95	-126.50			peak

**REMARKS:**

- (1) Measurement Value = Reading Level + Correct Factor.
- (2) Margin Level = Measurement Value - Limit Value.

**APPENDIX B - RADIATED EMISSION - 30 MHZ TO 1000 MHZ**

Test Mode	TX Mode_1Mbps Channel 00	Polarization	Vertical
-----------	--------------------------	--------------	----------

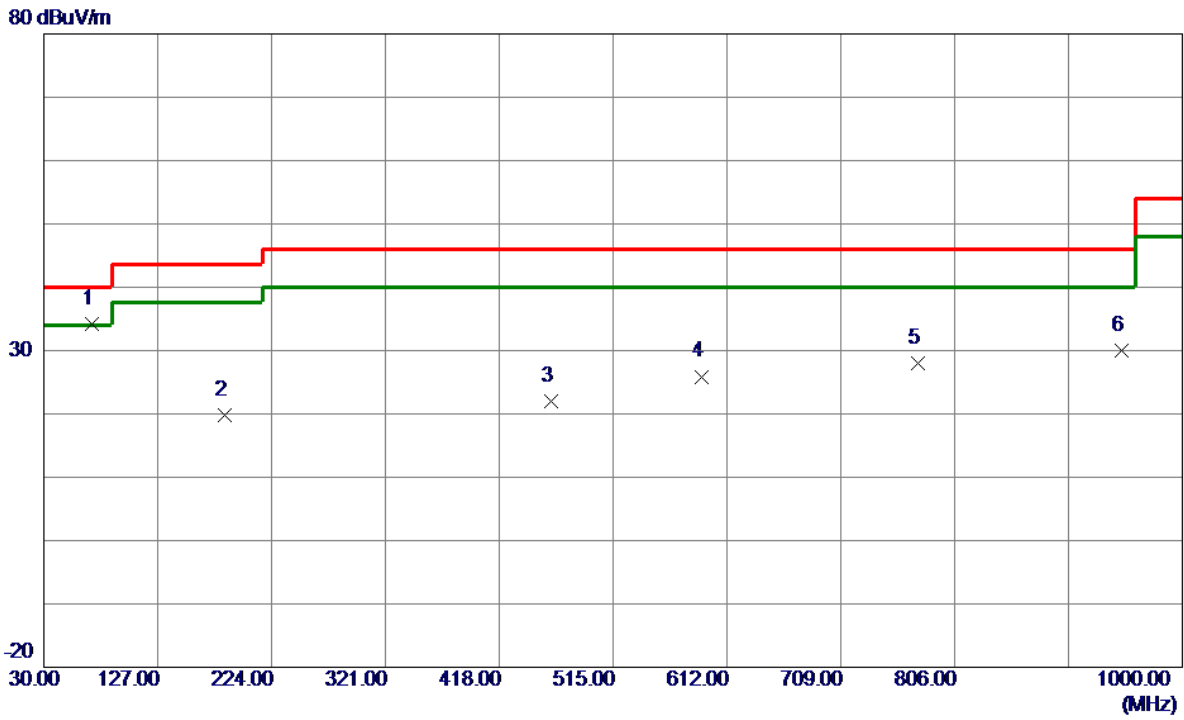

No.	Freq. MHz	Reading Level dBuV/m	Correct Factor dB	Measure ment dBuV/m	Limit dBuV/m	Margin dB	Detector	Comment
1 *	71.2250	52.66	-18.45	34.21	40.00	-5.79	Peak	
2	184.2300	37.18	-17.39	19.79	43.50	-23.71	Peak	
3	462.6200	32.72	-10.70	22.02	46.00	-23.98	Peak	
4	590.1750	33.62	-7.72	25.90	46.00	-20.10	Peak	
5	774.9600	33.37	-5.44	27.93	46.00	-18.07	Peak	
6	948.5900	33.36	-3.45	29.91	46.00	-16.09	Peak	

**REMARKS:**

- (1) Measurement Value = Reading Level + Correct Factor.
- (2) Margin Level = Measurement Value - Limit Value.

Test Mode	TX Mode_1Mbps Channel 00	Polarization	Horizontal
-----------	--------------------------	--------------	------------

80 dBuV/m

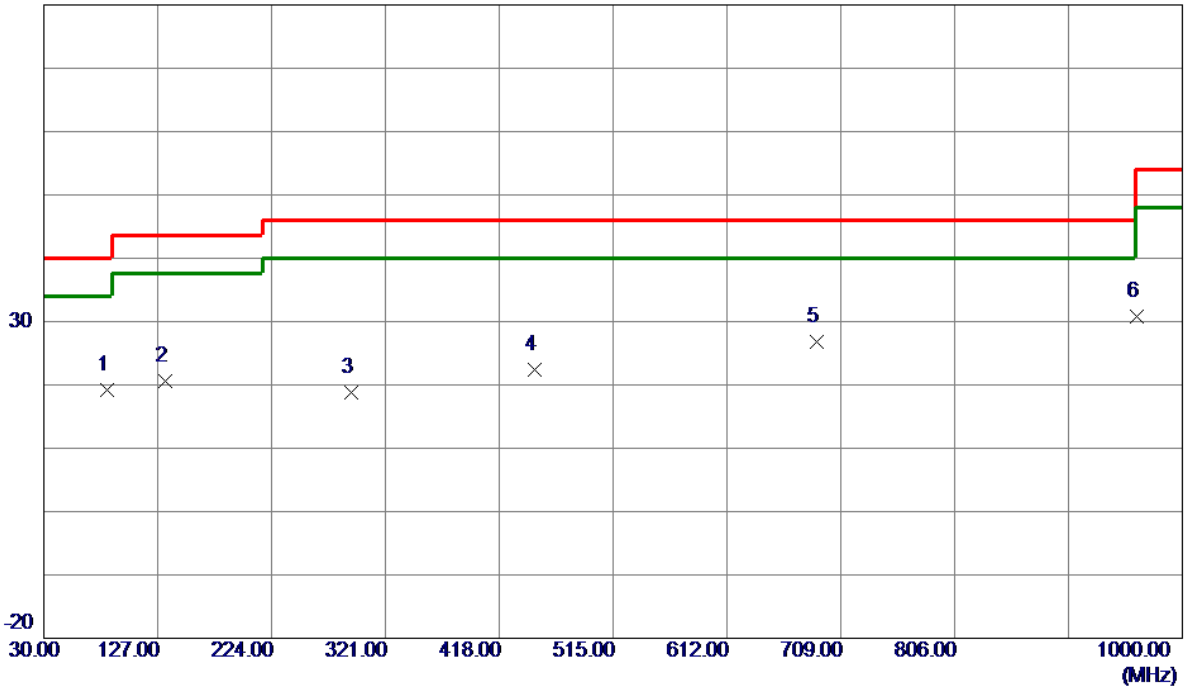

No.	Freq. MHz	Reading Level dBuV/m	Correct Factor dB	Measure ment dBuV/m	Limit dBuV/m	Margin dB	Detector	Comment
1	83.8350	40.52	-21.28	19.24	40.00	-20.76	Peak	
2	133.3049	37.15	-16.64	20.51	43.50	-22.99	Peak	
3	292.3850	33.40	-14.57	18.83	46.00	-27.17	Peak	
4	448.0700	33.41	-11.00	22.41	46.00	-23.59	Peak	
5 *	688.6300	33.83	-7.00	26.83	46.00	-19.17	Peak	
6	960.7150	34.11	-3.34	30.77	54.00	-23.23	Peak	

**REMARKS:**

- (1) Measurement Value = Reading Level + Correct Factor.
- (2) Margin Level = Measurement Value - Limit Value.



**APPENDIX C - RADIATED EMISSION - ABOVE 1000 MHZ**

Test Mode	TX 2402 MHz _CH00_1Mbps	Polarization	Vertical
-----------	-------------------------	--------------	----------

86.9 dBuV/m

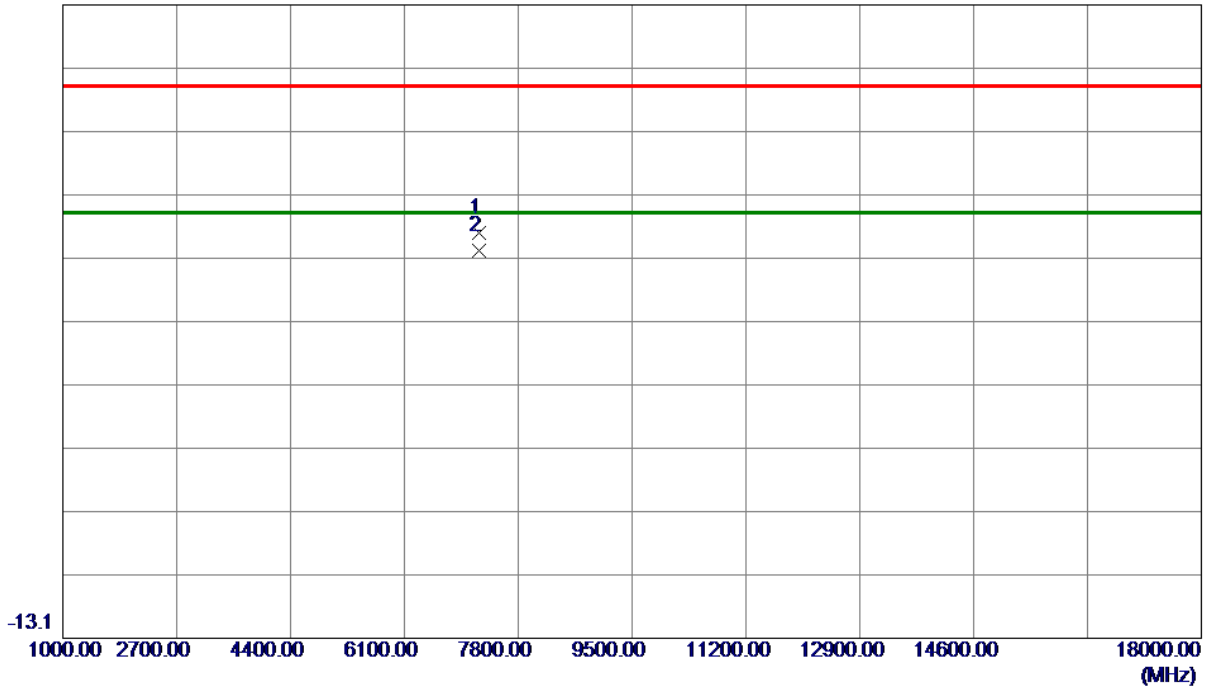

No.	Freq. MHz	Reading Level dBuV/m	Correct Factor dB	Measure ment dBuV/m	Limit dBuV/m	Margin dB	Detector	Comment
1	7205.8500	62.96	-11.98	50.98	74.00	-23.02	Peak	
2 *	7205.8500	60.08	-11.98	48.10	54.00	-5.90	AVG	

REMARKS:

- (1) Measurement Value = Reading Level + Correct Factor.
- (2) Margin Level = Measurement Value - Limit Value.

Test Mode	TX 2402 MHz _CH00_1Mbps	Polarization	Horizontal
-----------	-------------------------	--------------	------------

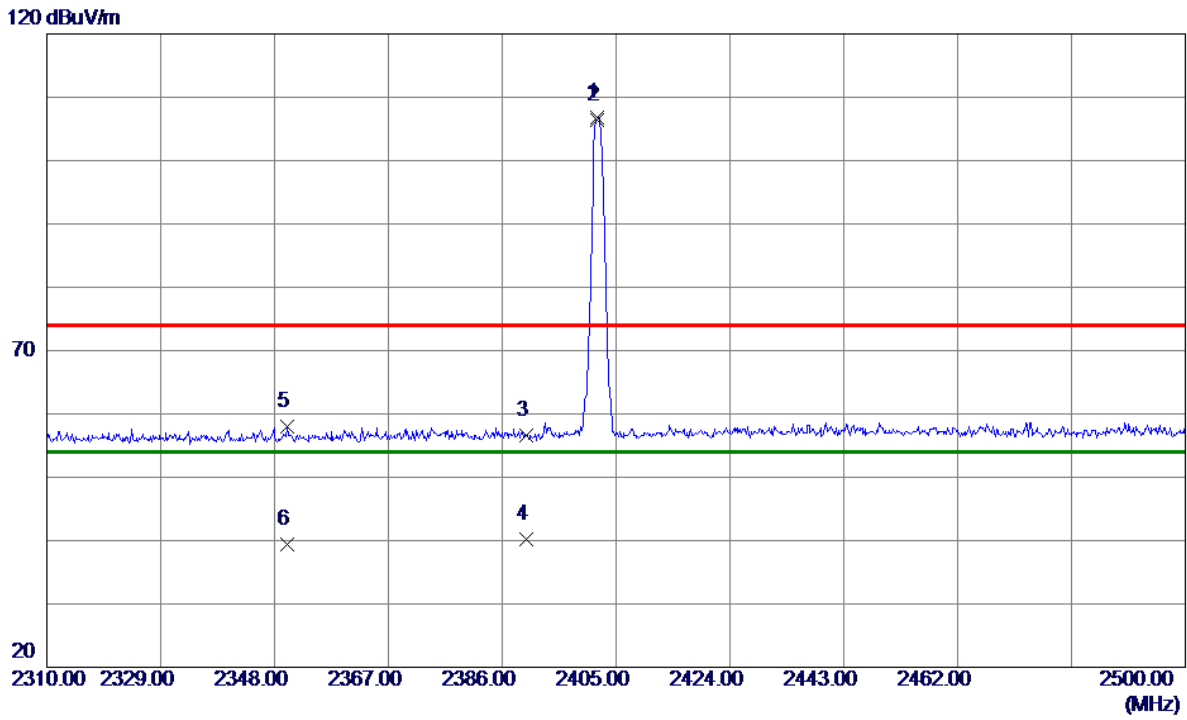

No.	Freq. MHz	Reading Level dBuV/m	Correct Factor dB	Measure ment dBuV/m	Limit dBuV/m	Margin dB	Detector	Comment
1	2401.8650	75.21	31.64	106.85	74.00	32.85	Peak	
2 *	2401.8650	74.71	31.64	106.35	54.00	52.35	AVG	
3	2390.0000	25.04	31.59	56.63	74.00	-17.37	Peak	
4	2390.0000	8.68	31.59	40.27	54.00	-13.73	AVG	
5	2350.1850	26.57	31.44	58.01	74.00	-15.99	Peak	
6	2350.1850	7.92	31.44	39.36	54.00	-14.64	AVG	

**REMARKS:**

- (1) Measurement Value = Reading Level + Correct Factor.
- (2) Margin Level = Measurement Value - Limit Value.

Test Mode	TX 2402 MHz _CH00_1Mbps	Polarization	Horizontal
-----------	-------------------------	--------------	------------

86.9 dBuV/m

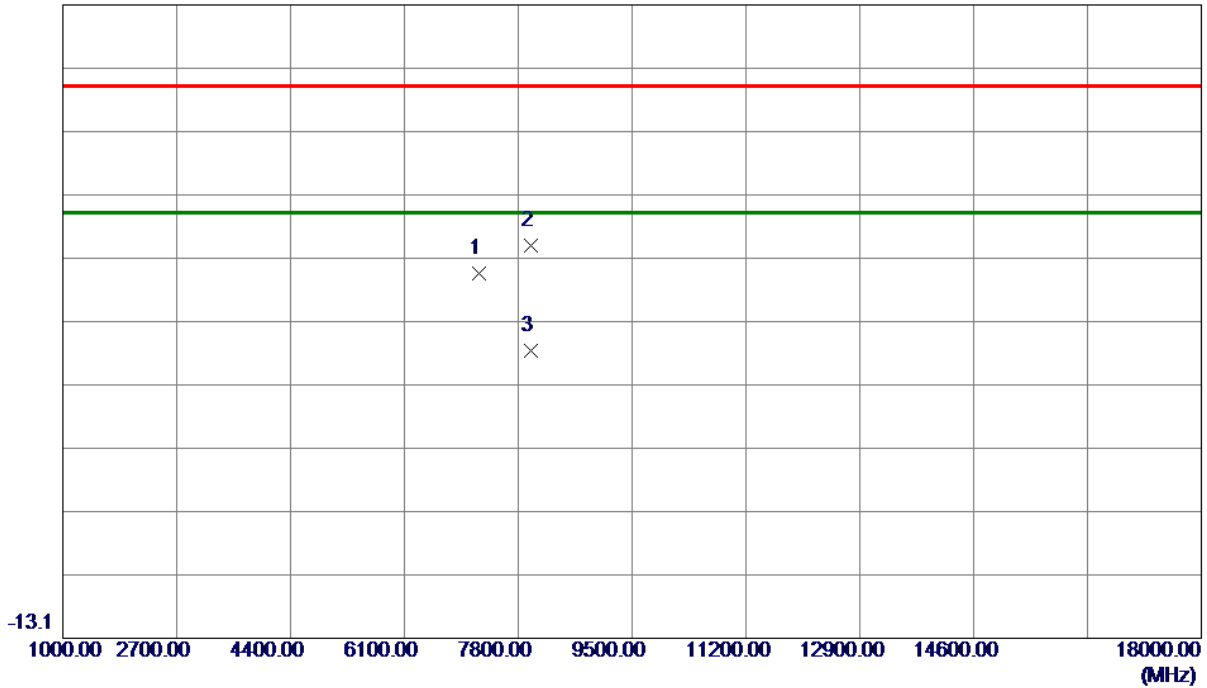

No.	Freq. MHz	Reading Level dBuV/m	Correct Factor dB	Measure ment dBuV/m	Limit dBuV/m	Margin dB	Detector	Comment
1	7206.7000	56.42	-11.98	44.44	74.00	-29.56	Peak	
2	7991.2500	59.67	-10.69	48.98	74.00	-25.02	Peak	
3 *	7991.2500	42.98	-10.69	32.29	54.00	-21.71	AVG	

REMARKS:

- (1) Measurement Value = Reading Level + Correct Factor.
- (2) Margin Level = Measurement Value - Limit Value.

Test Mode	TX 2441 MHz _CH39_1Mbps	Polarization	Vertical
-----------	-------------------------	--------------	----------

86.9 dBuV/m

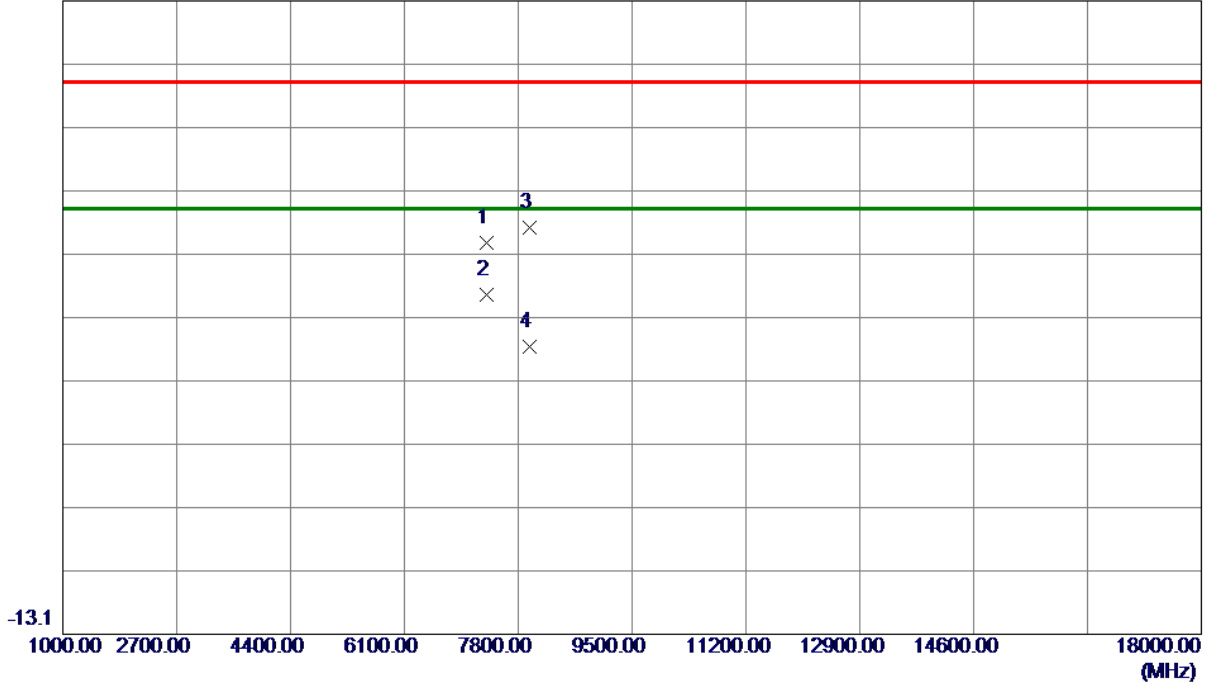

No.	Freq. MHz	Reading Level dBuV/m	Correct Factor dB	Measure ment dBuV/m	Limit dBuV/m	Margin dB	Detector	Comment
1	7322.3000	60.56	-11.76	48.80	74.00	-25.20	Peak	
2 *	7322.3000	52.22	-11.76	40.46	54.00	-13.54	AVG	
3	7976.8000	61.80	-10.71	51.09	74.00	-22.91	Peak	
4	7976.8000	42.96	-10.71	32.24	54.00	-21.76	AVG	

REMARKS:

- (1) Measurement Value = Reading Level + Correct Factor.
- (2) Margin Level = Measurement Value - Limit Value.

Test Mode	TX 2441 MHz _CH39_1Mbps	Polarization	Horizontal
-----------	-------------------------	--------------	------------

86.9 dBuV/m

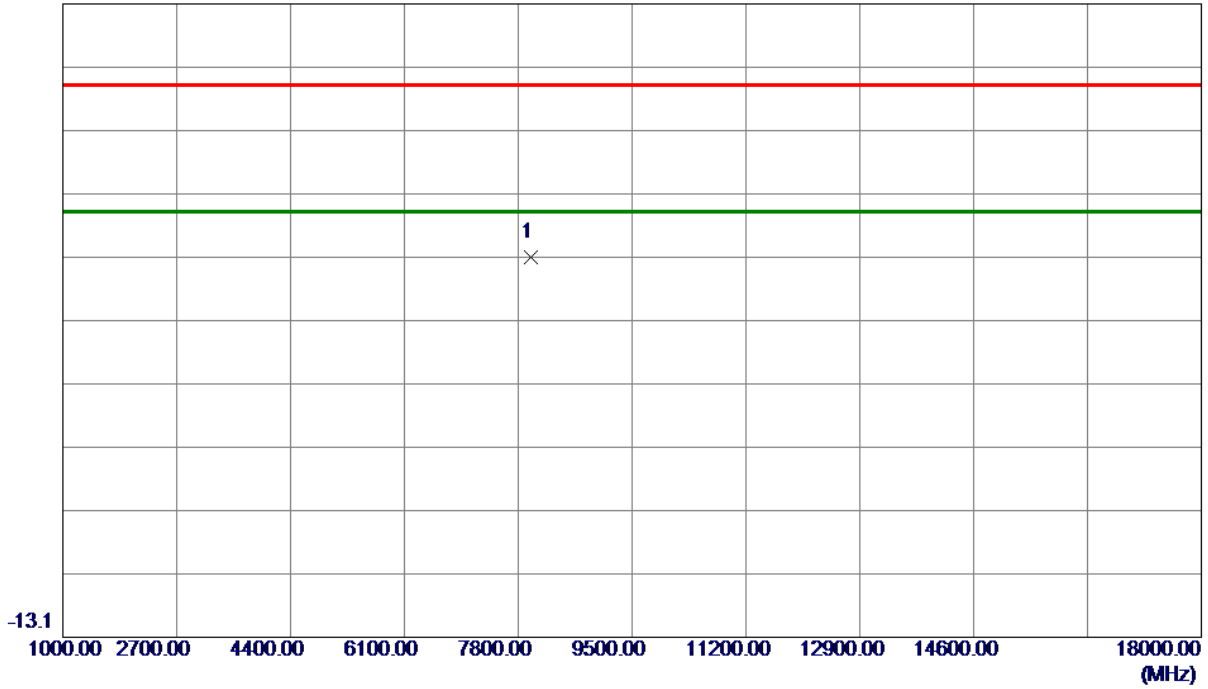

No.	Freq. MHz	Reading Level dBuV/m	Correct Factor dB	Measure ment dBuV/m	Limit dBuV/m	Margin dB	Detector	Comment
1 *	7980.2000	57.63	-10.71	46.92	74.00	-27.08	Peak	

REMARKS:

- (1) Measurement Value = Reading Level + Correct Factor.
- (2) Margin Level = Measurement Value - Limit Value.

Test Mode	TX 2480 MHz _CH78_1Mbps	Polarization	Vertical
-----------	-------------------------	--------------	----------

86.9 dBuV/m

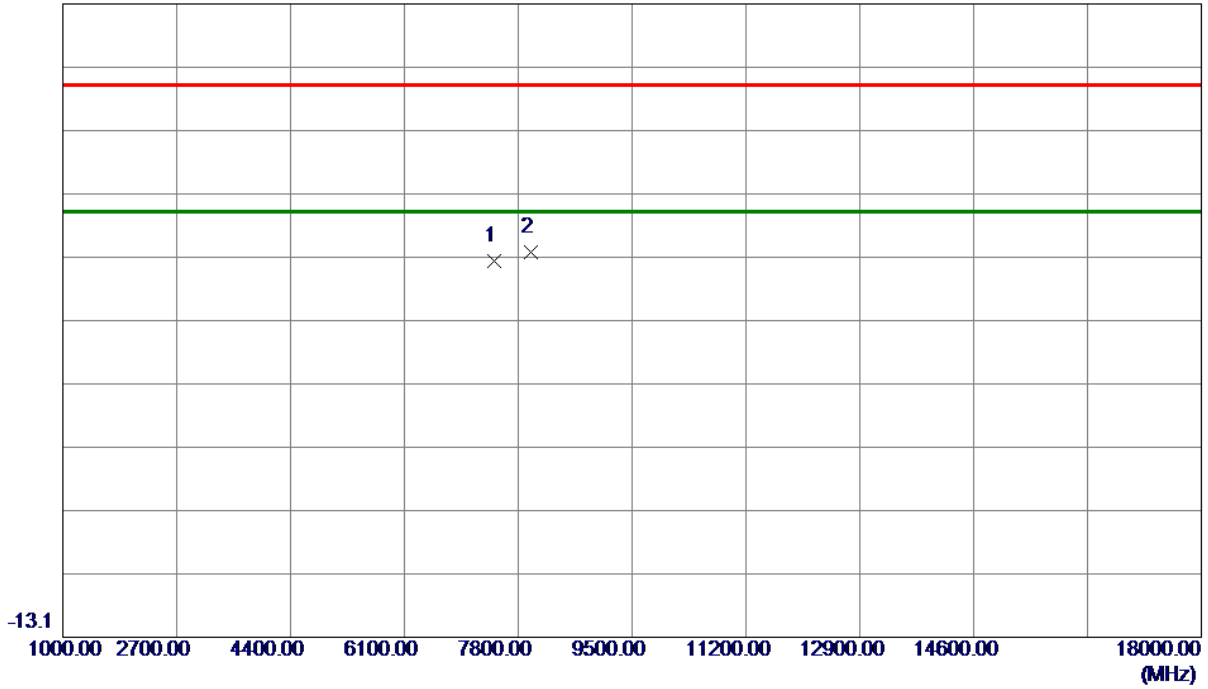

No.	Freq. MHz	Reading Level dBuV/m	Correct Factor dB	Measure ment dBuV/m	Limit dBuV/m	Margin dB	Detector	Comment
1	7439.6000	57.81	-11.52	46.29	74.00	-27.71	Peak	
2 *	7993.8000	58.40	-10.69	47.71	74.00	-26.29	Peak	

REMARKS:

- (1) Measurement Value = Reading Level + Correct Factor.
- (2) Margin Level = Measurement Value - Limit Value.

Test Mode	TX 2480 MHz _CH78_1Mbps	Polarization	Horizontal
-----------	-------------------------	--------------	------------

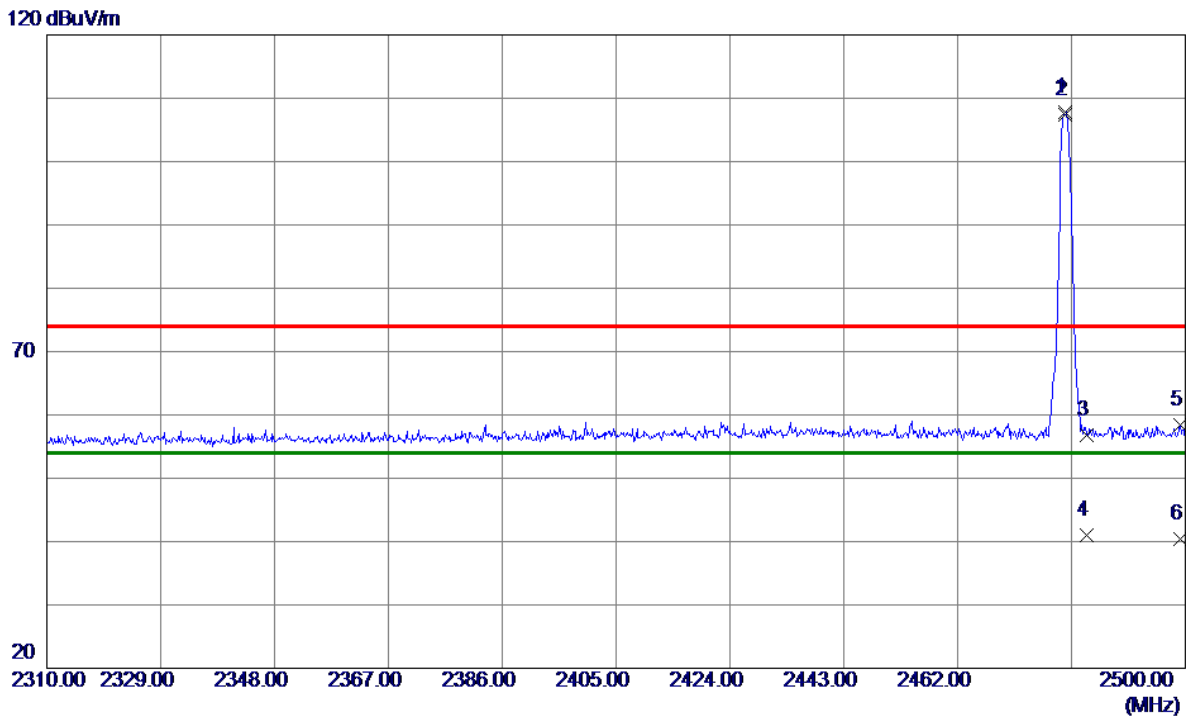

No.	Freq. MHz	Reading Level dBuV/m	Correct Factor dB	Measure ment dBuV/m	Limit dBuV/m	Margin dB	Detector	Comment
1	2479.9550	75.80	31.93	107.73	74.00	33.73	Peak	
2 *	2479.9550	75.43	31.93	107.36	54.00	53.36	AVG	
3	2483.5000	24.90	31.95	56.85	74.00	-17.15	Peak	
4	2483.5000	9.07	31.95	41.02	54.00	-12.98	AVG	
5	2499.0500	26.35	32.01	58.36	74.00	-15.64	Peak	
6	2499.0500	8.38	32.01	40.39	54.00	-13.61	AVG	

REMARKS:

- (1) Measurement Value = Reading Level + Correct Factor.
- (2) Margin Level = Measurement Value - Limit Value.



Test Mode	TX 2480 MHz _CH78_1Mbps	Polarization	Horizontal
-----------	-------------------------	--------------	------------

86.9 dBuV/m

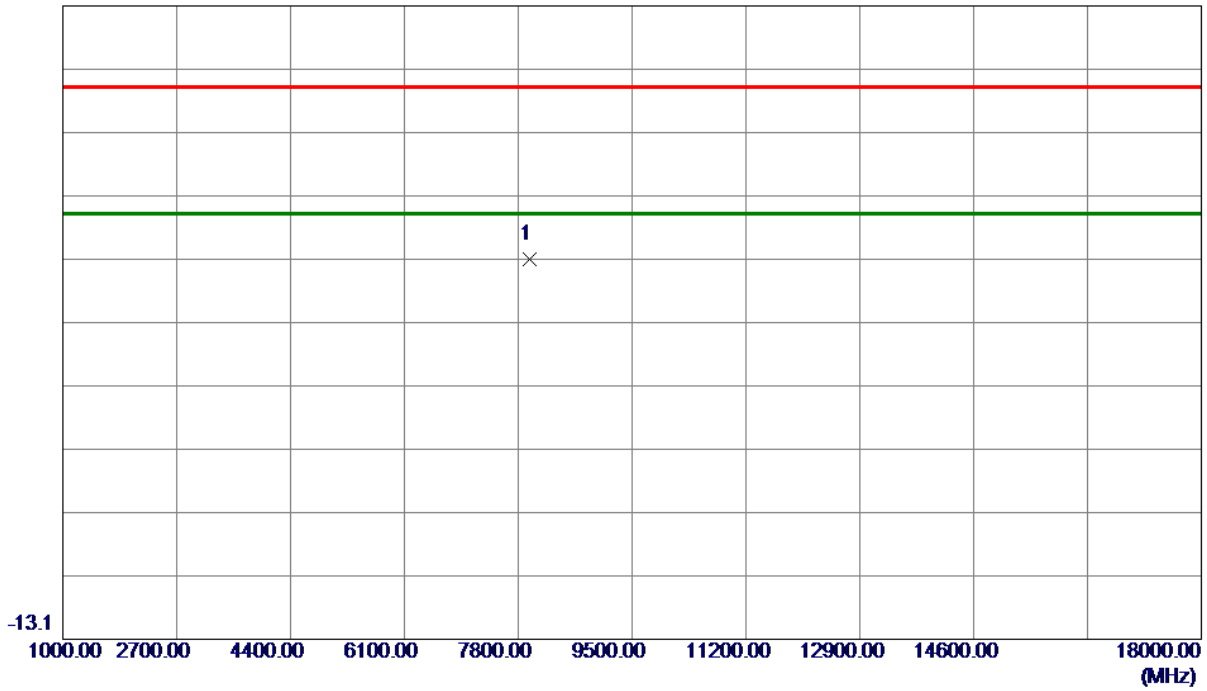

No.	Freq. MHz	Reading Level dBuV/m	Correct Factor dB	Measure ment dBuV/m	Limit dBuV/m	Margin dB	Detector	Comment
1 *	7977.6500	57.61	-10.71	46.90	74.00	-27.10	Peak	

REMARKS:

- (1) Measurement Value = Reading Level + Correct Factor.
- (2) Margin Level = Measurement Value - Limit Value.

Test Mode	TX 2402 MHz _CH00_3Mbps	Polarization	Vertical
-----------	-------------------------	--------------	----------

86.9 dBuV/m

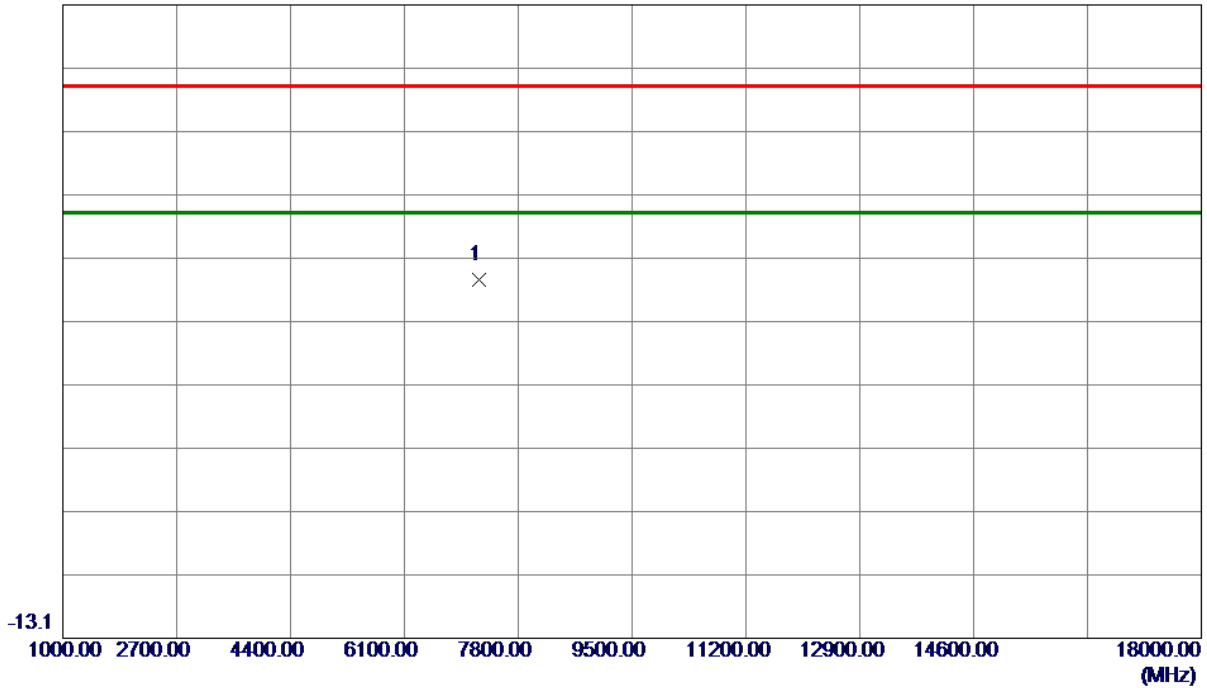

No.	Freq. MHz	Reading Level dBuV/m	Correct Factor dB	Measure ment dBuV/m	Limit dBuV/m	Margin dB	Detector	Comment
1 *	7205.8500	55.44	-11.98	43.46	74.00	-30.54	Peak	

REMARKS:

- (1) Measurement Value = Reading Level + Correct Factor.
- (2) Margin Level = Measurement Value - Limit Value.

Test Mode	TX 2402 MHz _CH00_3Mbps	Polarization	Horizontal
-----------	-------------------------	--------------	------------

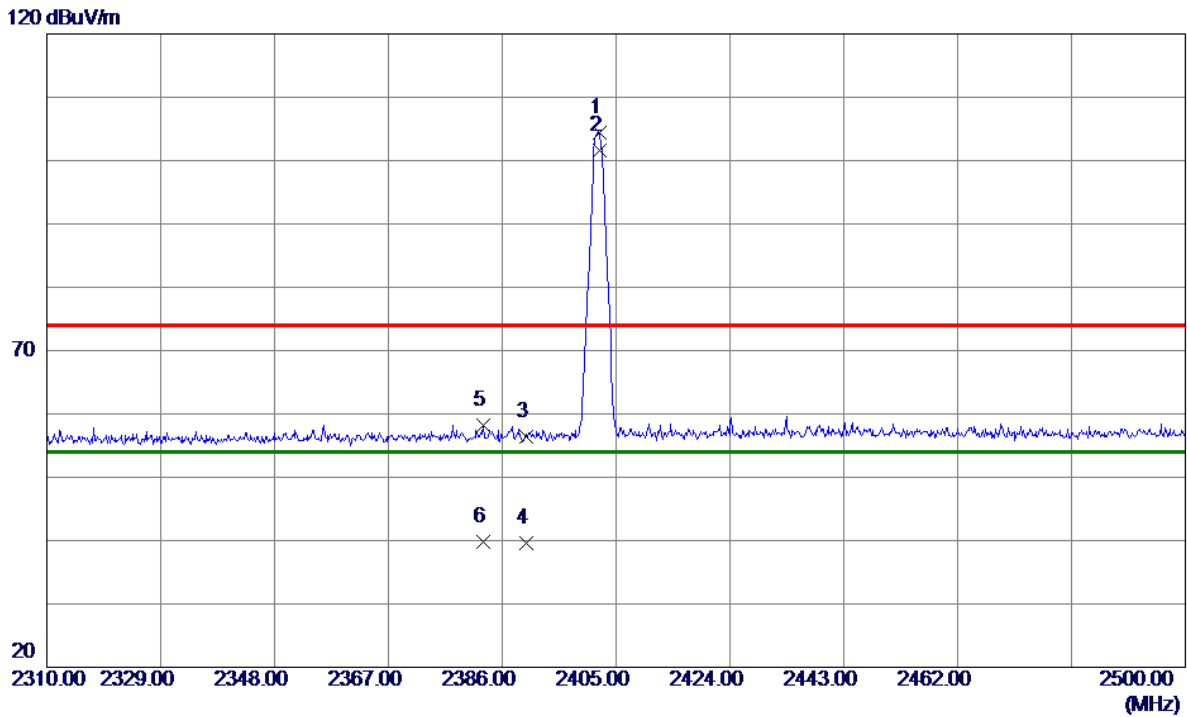

No.	Freq. MHz	Reading Level dBuV/m	Correct Factor dB	Measure ment dBuV/m	Limit dBuV/m	Margin dB	Detector	Comment
1	2402.1500	72.83	31.64	104.47	74.00	30.47	Peak	
2 *	2402.1500	70.03	31.64	101.67	54.00	47.67	AVG	
3	2390.0000	24.84	31.59	56.43	74.00	-17.57	Peak	
4	2390.0000	8.03	31.59	39.62	54.00	-14.38	AVG	
5	2382.7700	26.67	31.56	58.23	74.00	-15.77	Peak	
6	2382.7700	8.19	31.56	39.75	54.00	-14.25	AVG	

**REMARKS:**

- (1) Measurement Value = Reading Level + Correct Factor.
- (2) Margin Level = Measurement Value - Limit Value.

Test Mode	TX 2402 MHz _CH00_3Mbps	Polarization	Horizontal
-----------	-------------------------	--------------	------------

86.9 dBuV/m

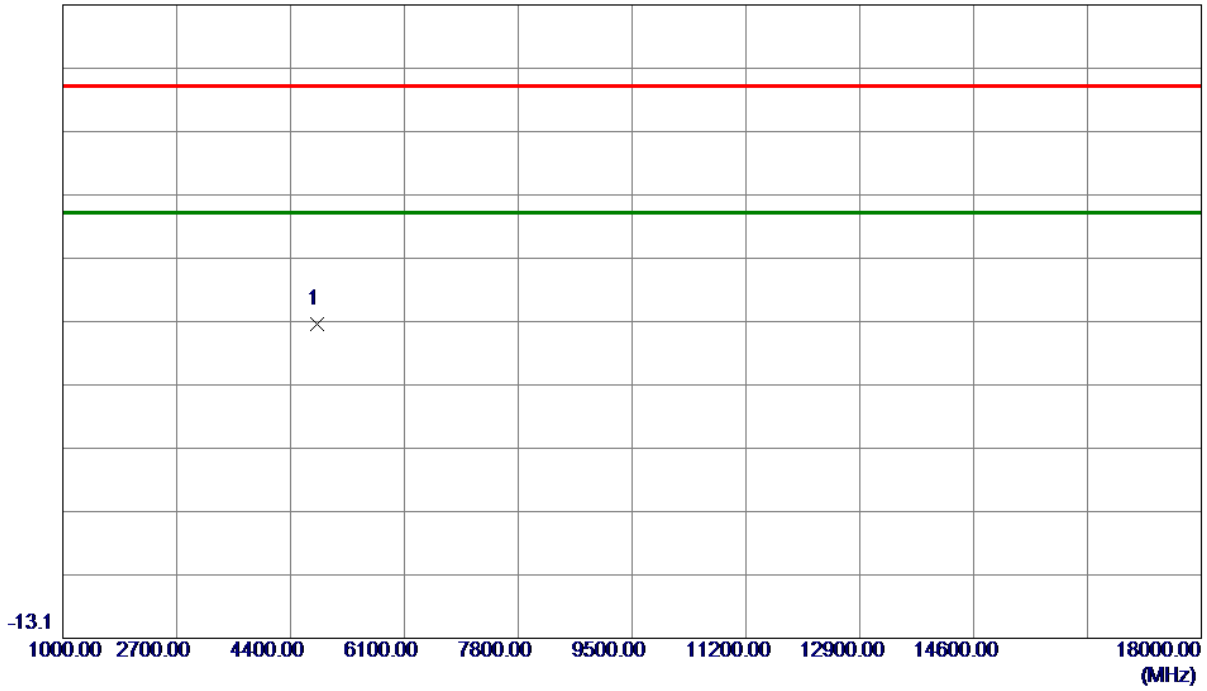

No.	Freq. MHz	Reading Level dBuV/m	Correct Factor dB	Measure ment dBuV/m	Limit dBuV/m	Margin dB	Detector	Comment
1 *	4804.0000	52.16	-15.69	36.47	74.00	-37.53	Peak	

REMARKS:

- (1) Measurement Value = Reading Level + Correct Factor.
- (2) Margin Level = Measurement Value - Limit Value.

Test Mode	TX 2441 MHz _CH39_3Mbps	Polarization	Vertical
-----------	-------------------------	--------------	----------

86.9 dBuV/m

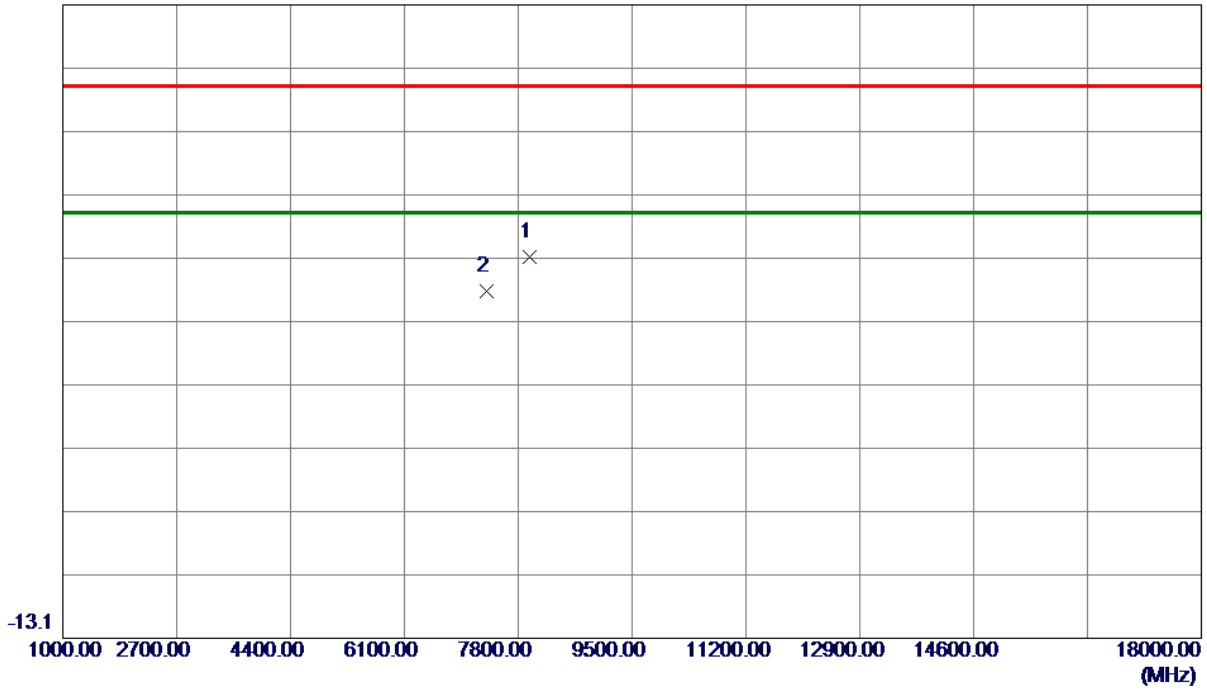

No.	Freq. MHz	Reading Level dBuV/m	Correct Factor dB	Measure ment dBuV/m	Limit dBuV/m	Margin dB	Detector	Comment
1 *	7977.6500	57.75	-10.71	47.04	74.00	-26.96	Peak	
2	7323.0000	53.46	-11.75	41.71	74.00	-32.29	Peak	

REMARKS:

- (1) Measurement Value = Reading Level + Correct Factor.
- (2) Margin Level = Measurement Value - Limit Value.

Test Mode	TX 2441 MHz _CH39_3Mbps	Polarization	Horizontal
-----------	-------------------------	--------------	------------

86.9 dBuV/m

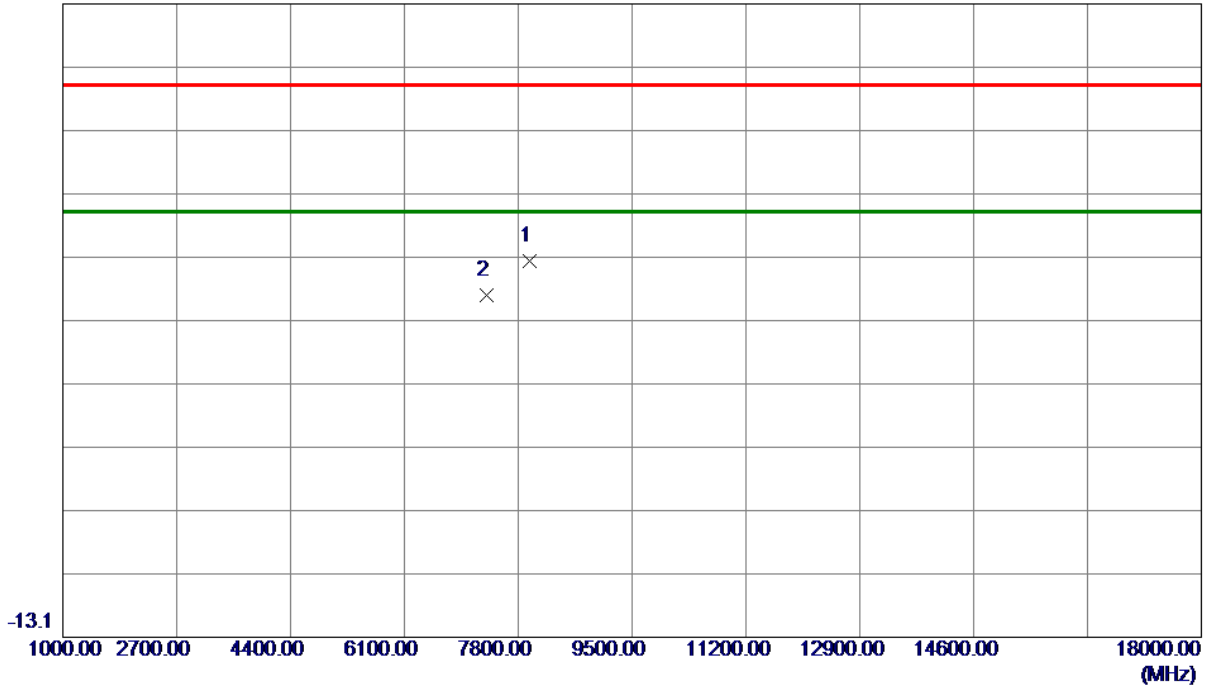

No.	Freq. MHz	Reading Level dBuV/m	Correct Factor dB	Measure ment dBuV/m	Limit dBuV/m	Margin dB	Detector	Comment
1 *	7964.0500	56.99	-10.73	46.26	74.00	-27.74	Peak	
2	7323.0000	52.58	-11.75	40.83	74.00	-33.17	Peak	

REMARKS:

- (1) Measurement Value = Reading Level + Correct Factor.
- (2) Margin Level = Measurement Value - Limit Value.

Test Mode	TX 2480 MHz _CH78_3Mbps	Polarization	Vertical
-----------	-------------------------	--------------	----------

86.9 dBuV/m

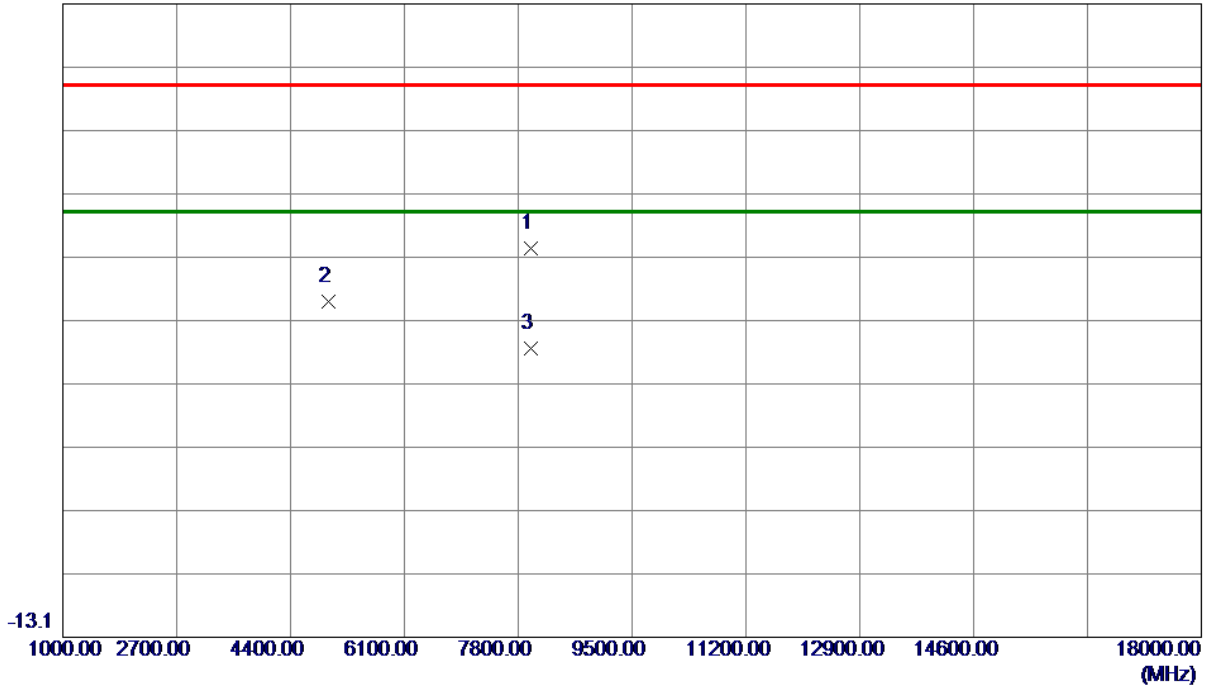

No.	Freq. MHz	Reading Level dBuV/m	Correct Factor dB	Measure ment dBuV/m	Limit dBuV/m	Margin dB	Detector	Comment
1	7985.3000	59.01	-10.70	48.31	74.00	-25.69	Peak	
2	4960.1500	55.04	-15.20	39.84	74.00	-34.16	Peak	
3 *	7985.3000	43.11	-10.70	32.41	54.00	-21.59	AVG	

REMARKS:

- (1) Measurement Value = Reading Level + Correct Factor.
- (2) Margin Level = Measurement Value - Limit Value.

Test Mode	TX 2480 MHz _CH78_3Mbps	Polarization	Horizontal
-----------	-------------------------	--------------	------------

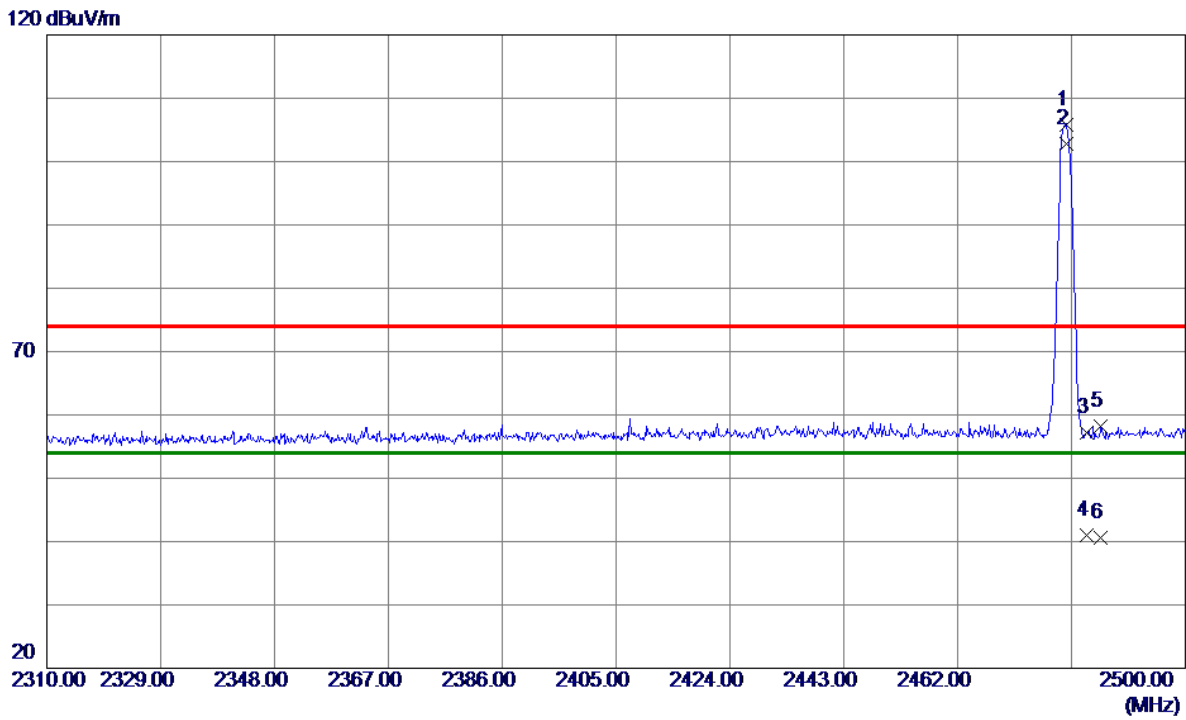

No.	Freq. MHz	Reading Level dBuV/m	Correct Factor dB	Measure ment dBuV/m	Limit dBuV/m	Margin dB	Detector	Comment
1	2480.0500	73.86	31.93	105.79	74.00	31.79	Peak	
2 *	2480.0500	70.81	31.93	102.74	54.00	48.74	AVG	
3	2483.5000	25.18	31.95	57.13	74.00	-16.87	Peak	
4	2483.5000	8.97	31.95	40.92	54.00	-13.08	AVG	
5	2485.9400	26.27	31.96	58.23	74.00	-15.77	Peak	
6	2485.9400	8.59	31.96	40.55	54.00	-13.45	AVG	

REMARKS:

- (1) Measurement Value = Reading Level + Correct Factor.
- (2) Margin Level = Measurement Value - Limit Value.



Test Mode	TX 2480 MHz _CH78_3Mbps	Polarization	Horizontal
-----------	-------------------------	--------------	------------

86.9 dBuV/m

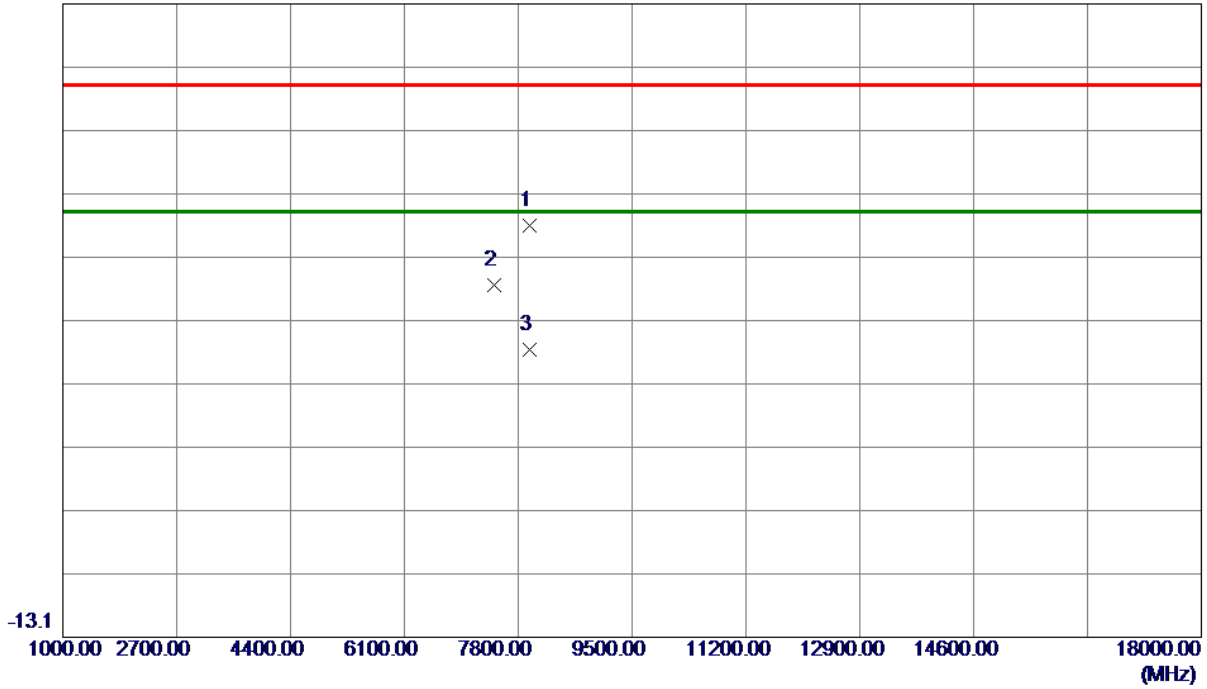

No.	Freq. MHz	Reading Level dBuV/m	Correct Factor dB	Measure ment dBuV/m	Limit dBuV/m	Margin dB	Detector	Comment
1	7973.4000	62.61	-10.72	51.89	74.00	-22.11	Peak	
2	7440.0000	54.10	-11.52	42.58	74.00	-31.42	Peak	
3 *	7973.4000	42.97	-10.72	32.25	54.00	-21.75	AVG	

REMARKS:

- (1) Measurement Value = Reading Level + Correct Factor.
- (2) Margin Level = Measurement Value - Limit Value.

Test Mode	TX 2402 MHz _CH00_1Mbps	Polarization	Vertical
-----------	-------------------------	--------------	----------

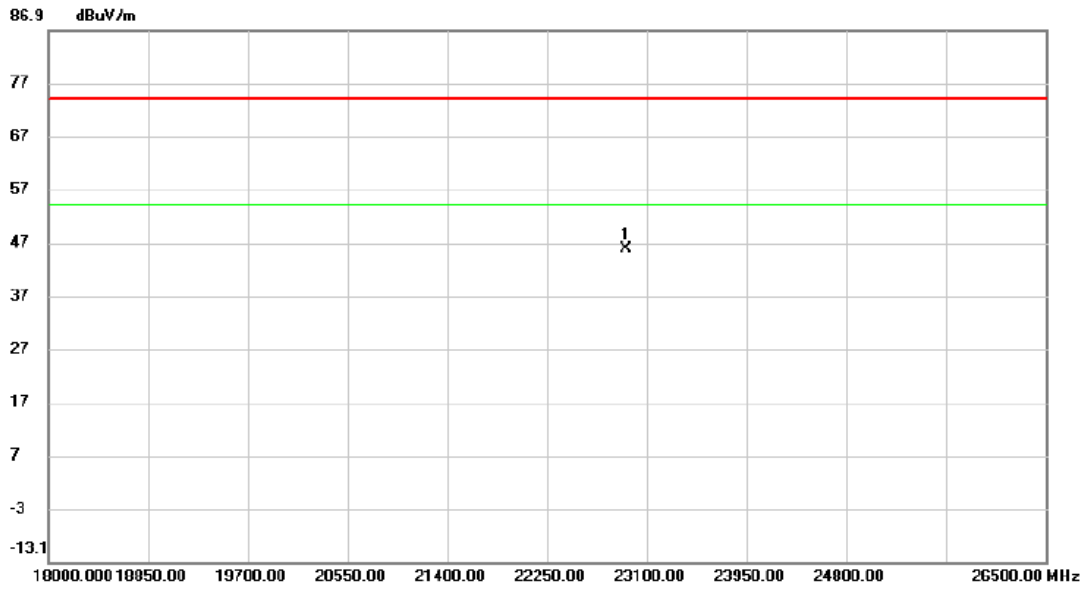

No.	Mk.	Freq.	Reading Level	Correct Factor	Measurement	Limit	Margin	Antenna Height	Table Degree	
		MHz	dBuV	dB	dBuV/m	dBuV/m	dB	cm	degree	Comment
1	*	22925.32	50.11	-4.28	45.83	74.00	-28.17			peak

**REMARKS:**

- (1) Measurement Value = Reading Level + Correct Factor.
- (2) Margin Level = Measurement Value - Limit Value.

Test Mode	TX 2402 MHz _CH00_1Mbps	Polarization	Horizontal
-----------	-------------------------	--------------	------------

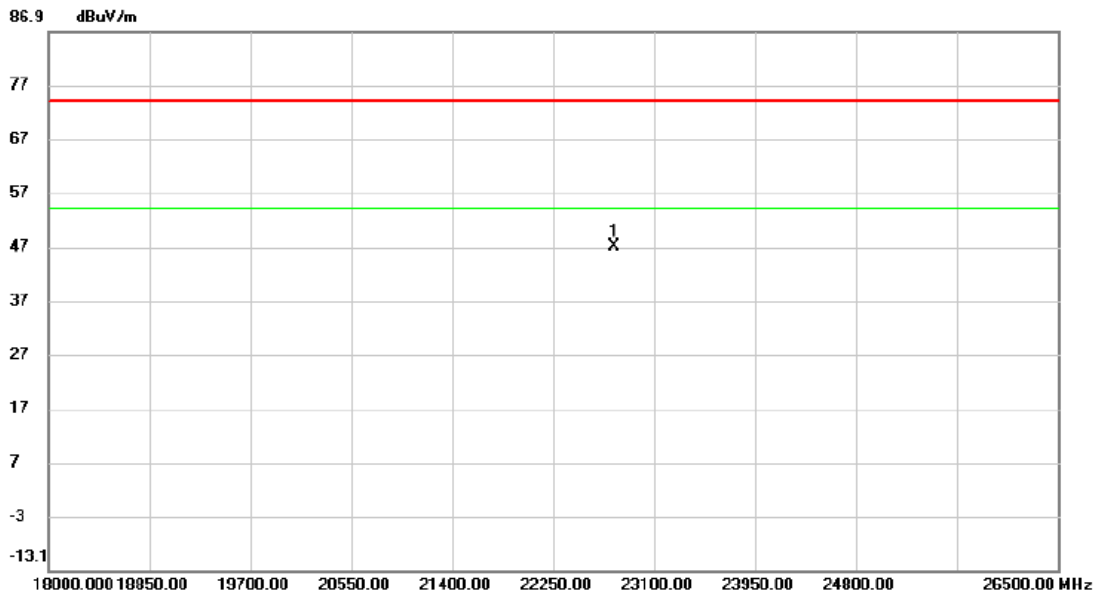

No.	Mk.	Freq.	Reading Level	Correct Factor	Measurement	Limit	Margin	Antenna Height	Table Degree	
		MHz	dBuV	dB	dBuV/m	dBuV/m	dB	cm	degree	Comment
1	*	22762.12	51.60	-4.68	46.92	74.00	-27.08			peak

**REMARKS:**

- (1) Measurement Value = Reading Level + Correct Factor.
- (2) Margin Level = Measurement Value - Limit Value.

**APPENDIX D - NUMBER OF HOPPING FREQUENCY**

Test Mode:	TX Mode_1Mbps
------------	---------------

Test Mode	Hopping Mode_1Mbps	Limit	Test Result
Number of Hopping Frequency	79	15	Pass

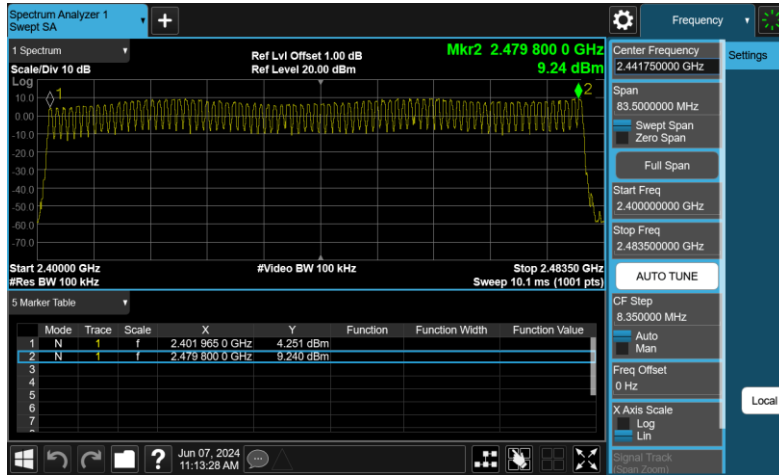

Test Mode:	TX Mode_3Mbps
------------	---------------

Test Mode	Hopping Mode_3Mbps	Limit	Test Result
Number of Hopping Frequency	79	15	Pass

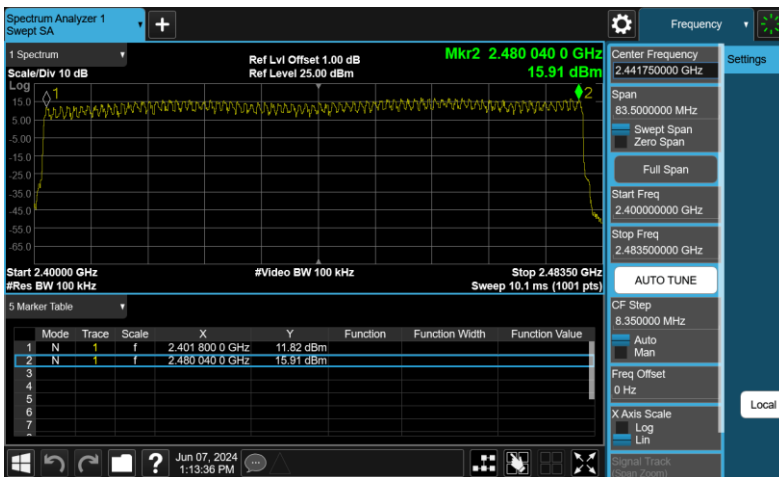

## **APPENDIX E - AVERAGE TIME OF OCCUPANCY**

Test Mode	Hopping Mode_1Mbps
-----------	--------------------

Data Packet	Frequency (MHz)	Pulse Duration (ms)	Dwell Time (s)	Limits (s)	Test Result
DH1	2402	0.3825	0.1224	0.4000	Pass
DH3	2402	1.6300	0.2608	0.4000	Pass
DH5	2402	2.8800	0.3072	0.4000	Pass
DH1	2441	0.3825	0.1224	0.4000	Pass
DH3	2441	1.6300	0.2608	0.4000	Pass
DH5	2441	2.8800	0.3072	0.4000	Pass
DH1	2480	0.3825	0.1224	0.4000	Pass
DH3	2480	1.6400	0.2624	0.4000	Pass
DH5	2480	2.8800	0.3072	0.4000	Pass





Test Mode	Hopping Mode_3Mbps
-----------	--------------------

Data Packet	Frequency (MHz)	Pulse Duration (ms)	Dwell Time (s)	Limits (s)	Test Result
3DH1	2402	0.3851	0.1232	0.4000	Pass
3DH3	2402	1.6300	0.2608	0.4000	Pass
3DH5	2402	2.8800	0.3072	0.4000	Pass
3DH1	2441	0.3851	0.1232	0.4000	Pass
3DH3	2441	1.6200	0.2592	0.4000	Pass
3DH5	2441	2.8600	0.3051	0.4000	Pass
3DH1	2480	0.3876	0.1240	0.4000	Pass
3DH3	2480	1.6300	0.2608	0.4000	Pass
3DH5	2480	2.8800	0.3072	0.4000	Pass



## **APPENDIX F - HOPPING CHANNEL SEPARATION**

Test Mode	Hopping Mode_1Mbps
-----------	--------------------

Channel	Frequency (MHz)	Channel Separation (MHz)	2/3 of 20 dB Bandwidth (MHz)	Test Result
00	2402	1.005	0.635	Pass
39	2441	1.009	0.634	Pass
78	2480	1.003	0.633	Pass

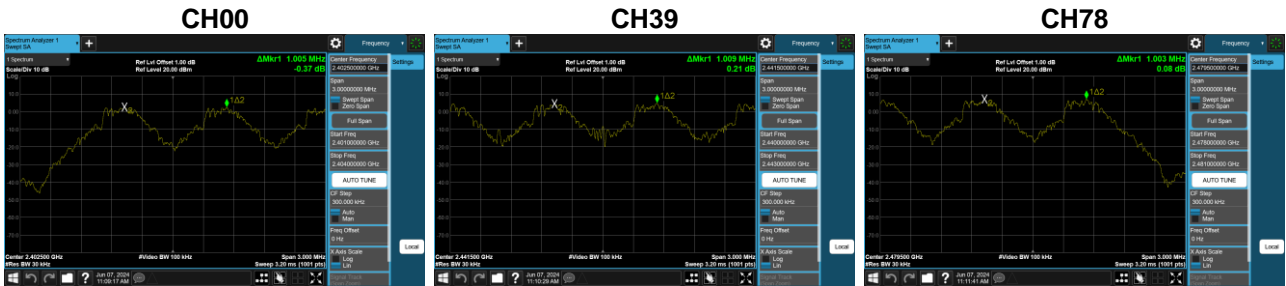

Test Mode	Hopping Mode_3Mbps
-----------	--------------------

Channel	Frequency (MHz)	Channel Separation (MHz)	2/3 of 20 dB Bandwidth (MHz)	Test Result
00	2402	0.996	0.879	Pass
39	2441	0.995	0.875	Pass
78	2480	1.010	0.874	Pass

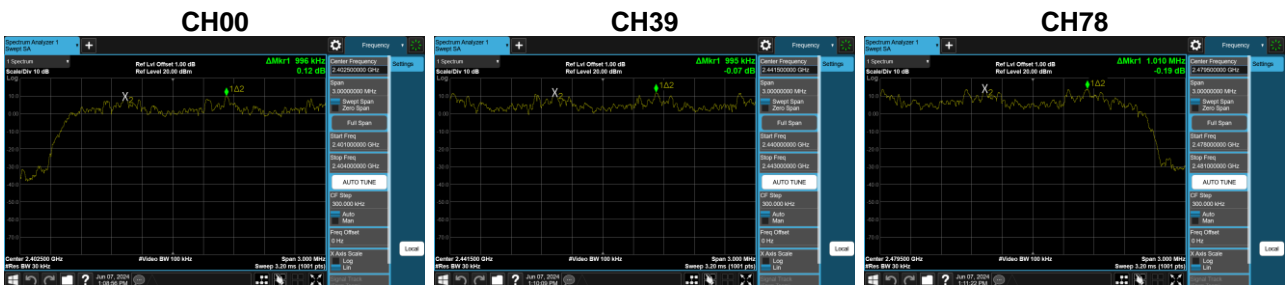

## APPENDIX G - BANDWIDTH

Test Mode	TX Mode _1Mbps
-----------	----------------

Channel	Frequency (MHz)	20 dB Bandwidth (MHz)	99 % Occupied Bandwidth (MHz)
00	2402	0.953	0.851
39	2441	0.950	0.845
78	2480	0.950	0.852

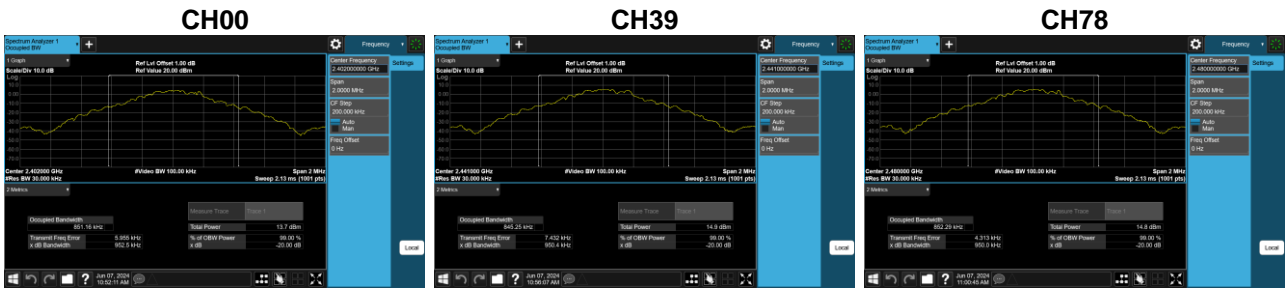

Test Mode	TX Mode _3Mbps
-----------	----------------

Channel	Frequency (MHz)	20 dB Bandwidth (MHz)	99 % Occupied Bandwidth (MHz)
00	2402	1.318	1.186
39	2441	1.313	1.184
78	2480	1.312	1.188

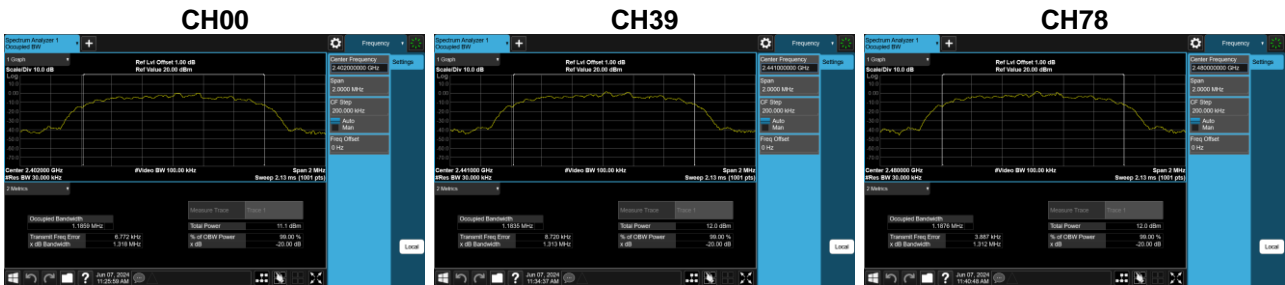

## **APPENDIX H - MAXIMUM OUTPUT POWER**

Test Mode	TX Mode _1Mbps
-----------	----------------

Channel	Frequency (MHz)	Output Power (dBm)	Max. Limit (dBm)	Max. Limit (W)	Test Result
00	2402	6.99	20.97	0.1250	Pass
39	2441	7.97	20.97	0.1250	Pass
78	2480	8.08	20.97	0.1250	Pass

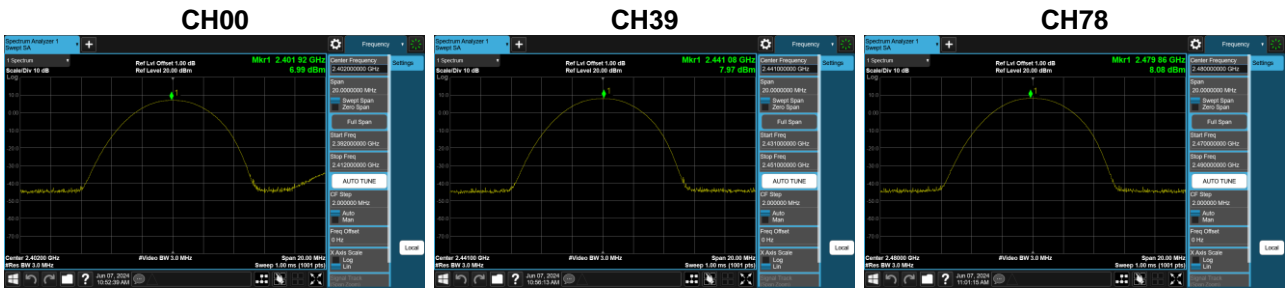



Test Mode	TX Mode _2Mbps
-----------	----------------

Channel	Frequency (MHz)	Output Power (dBm)	Max. Limit (dBm)	Max. Limit (W)	Test Result
00	2402	6.14	20.97	0.1250	Pass
39	2441	6.86	20.97	0.1250	Pass
78	2480	7.40	20.97	0.1250	Pass

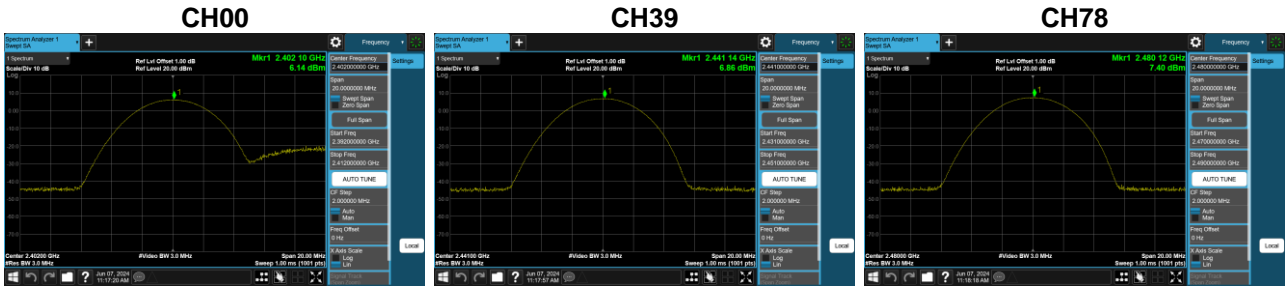

Test Mode	TX Mode _3Mbps
-----------	----------------

Channel	Frequency (MHz)	Output Power (dBm)	Max. Limit (dBm)	Max. Limit (W)	Test Result
00	2402	6.80	20.97	0.1250	Pass
39	2441	7.61	20.97	0.1250	Pass
78	2480	7.41	20.97	0.1250	Pass

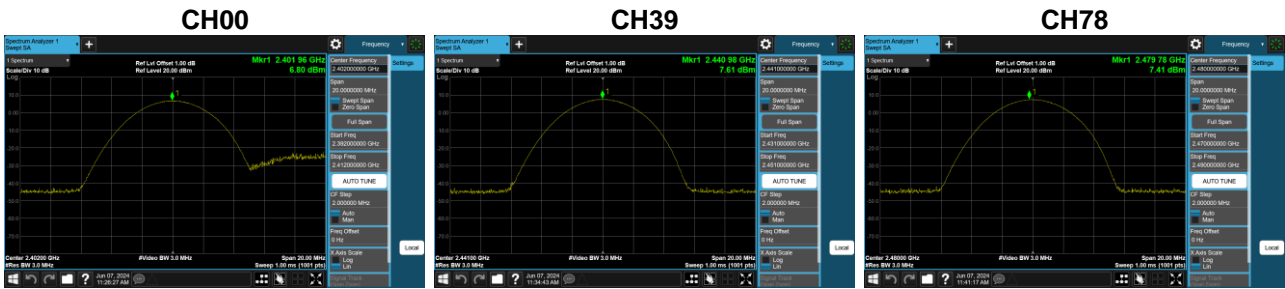

## **APPENDIX I - CONDUCTED SPURIOUS EMISSION**

Test Mode TX Mode \_1Mbps

**Bandedge CH00 (Lower)**

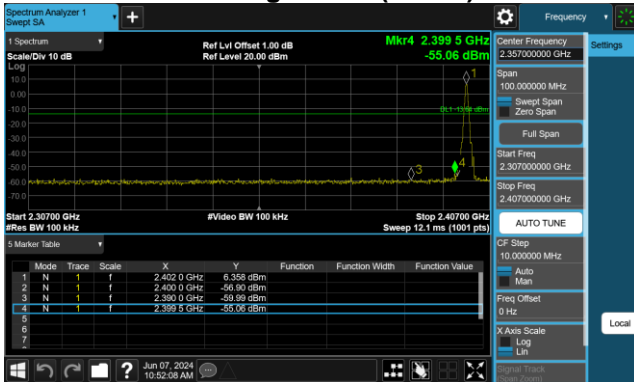

**Bandedge CH78 (Upper)**

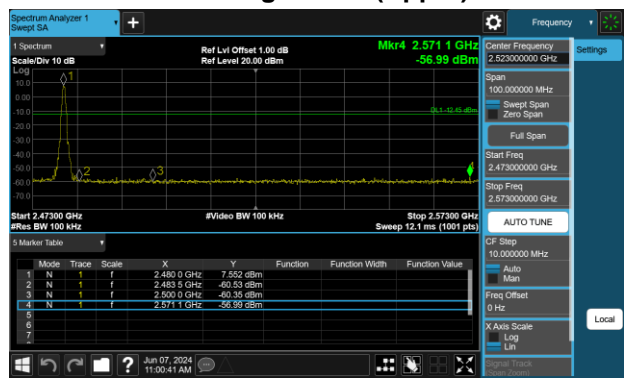

**Hopping on mode (Lower)**

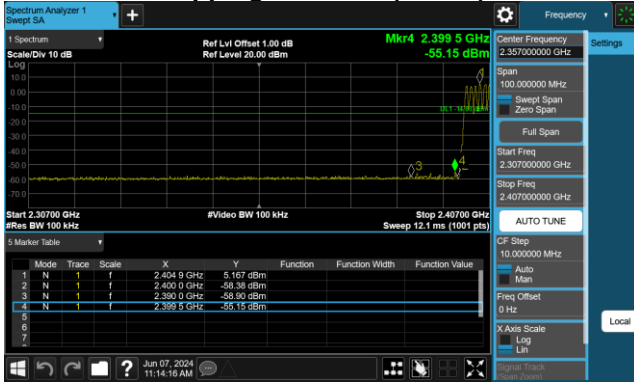

**Hopping on mode (Upper)**

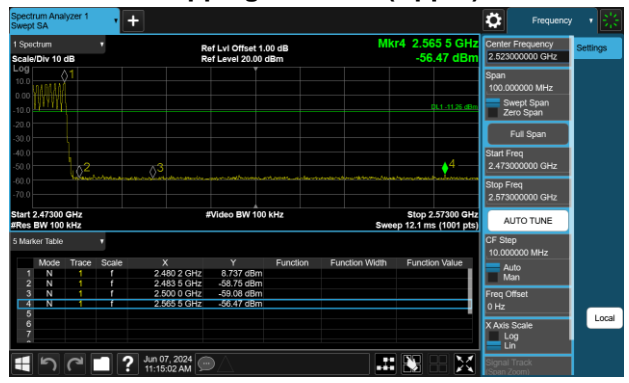

**CH00 – 10th Harmonic of the fundamental frequency**

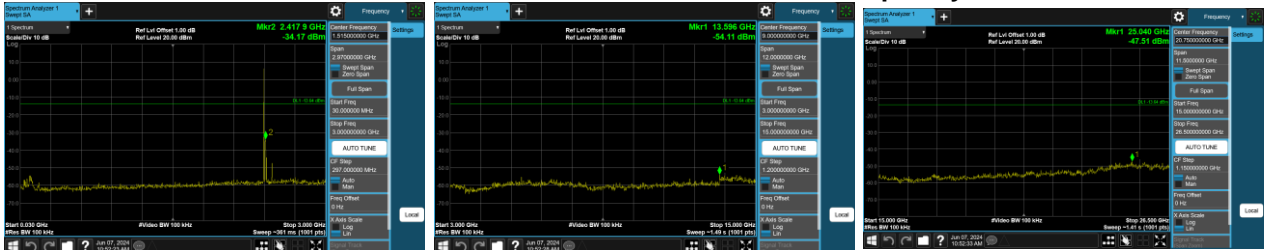

**CH39 – 10th Harmonic of the fundamental frequency**

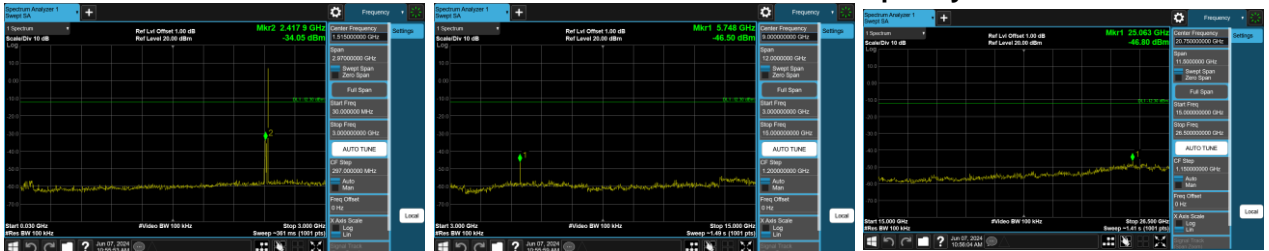

**CH78 – 10th Harmonic of the fundamental frequency**

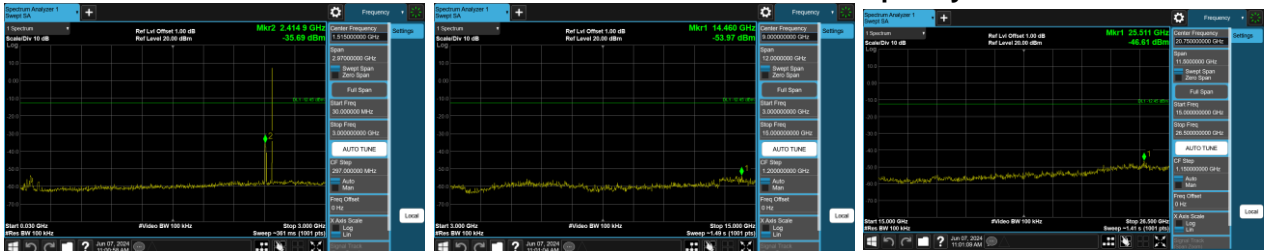

Test Mode TX Mode \_3Mbps

### Bandedge CH00 (Lower)

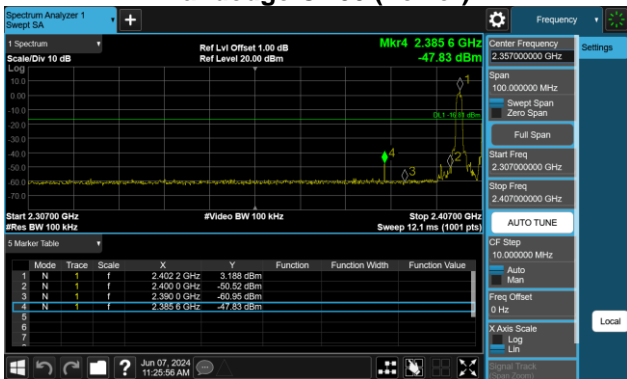

### Bandedge CH78 (Upper)

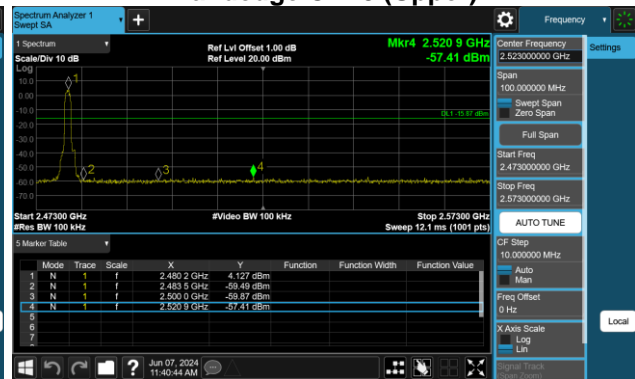

### Hopping on mode (Lower)

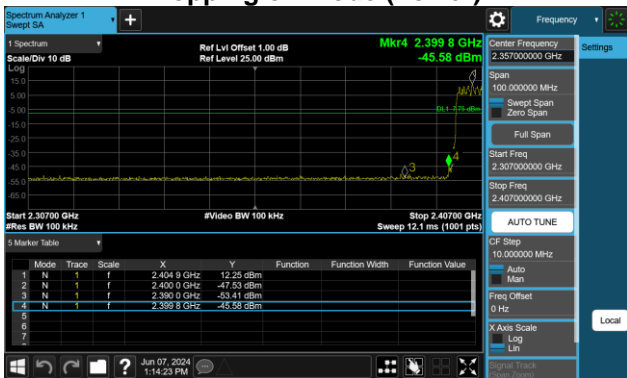

### Hopping on mode (Upper)

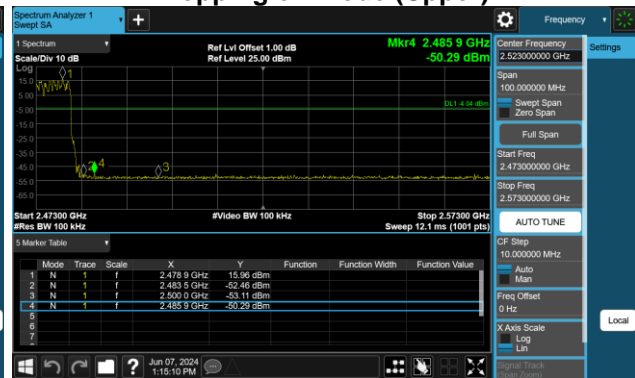

### CH00 – 10th Harmonic of the fundamental frequency

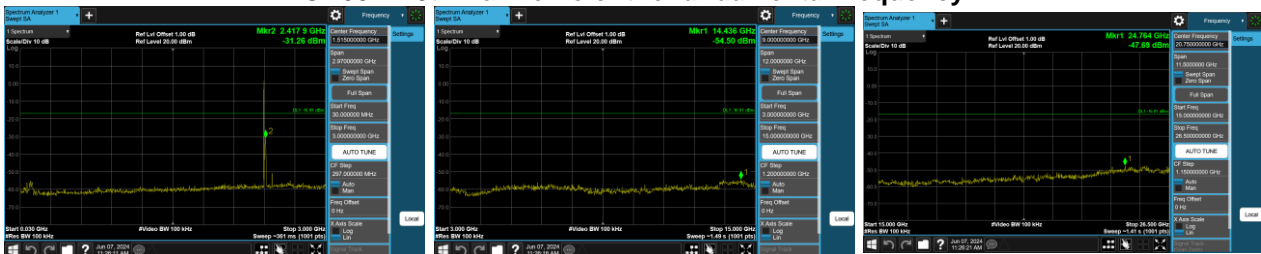

### CH39 – 10th Harmonic of the fundamental frequency

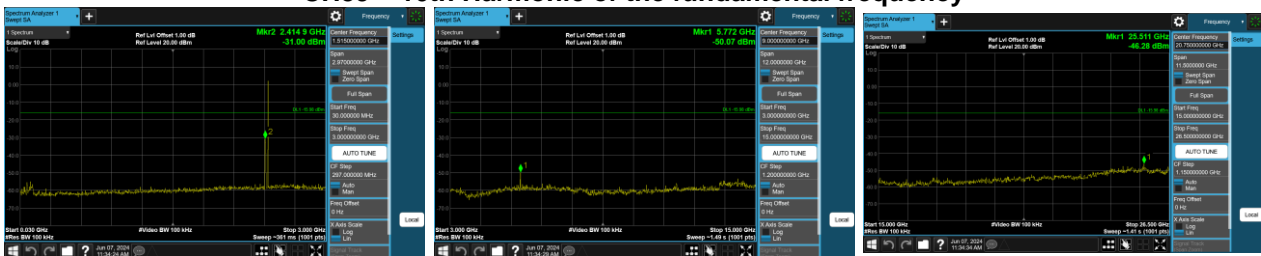

### CH78 – 10th Harmonic of the fundamental frequency

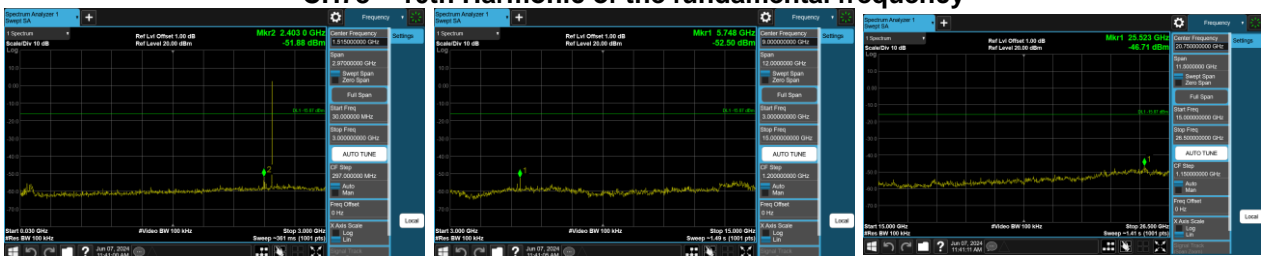

## **APPENDIX J - DECLARATION FOR BLUETOOTH DEVICE**

**1. Output power and channel separation of a Bluetooth device in the different operating modes:**

The different operating modes (data-mode, acquisition-mode) of a Bluetooth device has no influence on the output power and the channel spacing. There is only one transmitter which is driven by identical input parameters concerning these two parameters.

Only a different hopping sequence will be used. For this reason the check of these RF parameters in one op-mode is sufficient.

**2. Frequency range of a Bluetooth device:**

Hereby we declare that the maximum frequency of this device is: 2402 - 2480MHz. This is according to the Bluetooth Core Specification (+ critical errata) for devices which will be operated in the USA.

This was checked during the Bluetooth Qualification tests (Test Case: TRM/CA/04-E). Other frequency ranges (e.g. for Spain, France, Japan) which are allowed according the Core Specification are not supported by this device.

**3. Co-ordination of the hopping sequence in data mode to avoid simultaneous occupancy by multiple transmitters:**

Bluetooth units which want to communicate with other units must be organised in a structure called piconet. This piconet consist of max. 8 Bluetooth units. One unit is the master the other seven are the slaves. The master co-ordinates frequency occupation in this piconet for all units. As the master hop sequence is derived from its BD address which is unique for each Bluetooth device, additional masters intending to establish new piconets will always use different hop sequences.

**4. Example of a hopping sequence in data mode:**

Example of a 79 hopping sequence in data mode:

40, 21, 44, 23, 42, 53, 46, 55, 48, 33, 52, 35, 50, 65, 54, 67, 56, 37, 60, 39, 58, 69, 62, 71, 64, 25, 68, 27, 66, 57, 70, 59, 72, 29, 76, 31, 74, 61, 78, 63, 01, 41, 05, 43, 03, 73, 07, 75, 09, 45, 13, 47, 11, 77, 15, 00, 64, 49, 66, 53, 68, 02, 70, 06, 01, 51, 03, 55, 05, 04

**5. Equally average use of frequencies in data mode and behaviour for short transmissions:**

The generation of the hopping sequence in connection mode depends essentially on two input values:

- a) LAP/UAP of the master of the connection.
- b) Internal master clock.

The LAP (lower address part) are the 24 LSB's of the 48 BD\_ADDRESS. The BD\_ADDRESS is an unambiguous number of every Bluetooth unit. The UAP (upper address part) are the 24 MSB's of the 48 BD\_ADDRESS.

The internal clock of a Bluetooth unit is derived from a free running clock which is never adjusted and is never turned off. For synchronisation with other units only offset are used. It has no relation to the time of the day. Its resolution is at least half the RX/TX slot length of 312.5  $\mu$ s. The clock has a cycle of about one day (23h30). In most case it is implemented as 28 bit counter. For the deriving of the hopping sequence the entire.

LAP (24 bits), 4 LSB's (4 bits) (Input 1) and the 27 MSB's of the clock (Input 2) are used. With this input values different mathematical procedures (permutations, additions, XOR- operations) are performed to generate the sequence. This will be done at the beginning of every new transmission.

Regarding short transmissions the Bluetooth system has the following behaviour:

The first connection between the two devices is established, a hopping sequence was generated. For transmitting the wanted data the complete hopping sequence was not used. The connection ended.

The second connection will be established. A new hopping sequence is generated. Due to the fact that the Bluetooth clock has a different value, because the period between the two transmission is longer (and it cannot be shorter) than the minimum resolution of the clock (312.5  $\mu$ s). The hopping sequence will always differ from the first one.

**6. Receiver input bandwidth and behaviour for repeated single or multiple packets:**

The input bandwidth of the receiver is 1 MHz. In every connection one Bluetooth device is the master and the other one is the slave. The master determines the hopping sequence (see chapter 5). The slave follows this sequence. Both devices shift between RX and TX time slot according to the clock of the master.

Additionally the type of connection (e.g. single or multislot packet) is set up at the beginning of the connection. The master adapts its hopping frequency and its TX/RX timing according to the packet type of the connection. Also the slave of the connection will use these settings.

Repeating of a packet has no influence on the hopping sequence. The hopping sequence generated by the master of the connection will be followed in any case. That means, a repeated packet will not be send on the same frequency, it is send on the next frequency of the hopping sequence.

**End of Test Report**