



深圳市立诚兴科技有限公司

SHENZHEN LICHENGXING TECHNOLOGY CO., LTD

## 承 认 书

### SPECIFICATION FOR APPROVAL

客 户:

CUSTOMER:

客 户 料 号:

CUST P/N:

Receiving Coil

内 部 料 号 :

LCX P/N:

LCX-KH187003

产 品 型 号:

DESC:

Ø16.5\*40-0.07\*100P-11TS-50-43.52L0C-BJ

日 期:

DATE:

2024/6/20

版 本:

Version:

A.0

制作 PREPARED BY	审核 CHECKED BY	批准 APPROVED BY	客户承认 CUSTOMER APPROVE
Xiong Gang 2023/6/20	Frank Gao 2023/6/20		

Adress: 401, Block B, Building 7, Rongchang Industrial Park, No. 440, Hedong village, Hengkeng community, Guancheng Street, Longhua District, Shenzhen

PH: 13828741697

E-mail: 467317369@qq.com

产品规格书 SPECIFICATION		Version A/0	PREPARED BY: Xiong Gang 2023/6/20	CHECKED BY: Frank Gao 2023/6/20
Drawing No: LCX-GCQP000957		Page No: 2/4	客户代码: CUST CODE	KH187003
Specification	Ø16.5*40-0.07*100P-11TS-50-43.52LOC	客户料号: CUST P/N		Receiving Coil
		内部料号: IN P/N		LXC-KH187003
<h2>版本变更履历</h2> <h3>Version Change History</h3>				

版本 Rev	变更前 Before Change	变更后 After Change	更改日期 Change Date	批准 Approved By
A/0	New Release	-----	2023/6/20	Frank Gao

## 物料清单

### Bill of material

NO.	Item Name	IN P/N	Material Specification	Unit	Usage	Remarks
1	Coil		Litz Wire 0.07*100	g	5.5	
2	Flexible Ferrite		43.5*5.3*1.0	PCS	1	The outer diameter of the magnetic chip cannot exceed 43.5.
3	High Temperature Adhesive Tape		9*15	PCS	1	
		Blank				

产品规格书 SPECIFICATION							Version A/0	PREPARED BY: Xiong Gang 2023/6/20	CHECKED BY: Frank Gao 2023/6/20				
Drawing No: LCX-GCQP000957							Page No: 3/4	客户代码: CUST CODE	KH187003				
Specification Ø16.5*40-0.07*100P-11TS-50-43.52L0C							客户料号: CUST P/N			Receiving Coil			
							内部料号: IN P/N			LXC-KH187003			
A	B	C	D	E	F	H	H1	H2	---	---	---	---	---
16.5±0.5	39.5-40.5	5.3±0.3	42.8-43.5	3±1	50±2	2.1 MAX	1.1±0.15	0.8±0.1	---	---	---	---	---

一. 尺寸 DIMENSION:(mm) Winding Mold:Ø16.5 Coil Single Weight: 5.5

Figure 1: Coil

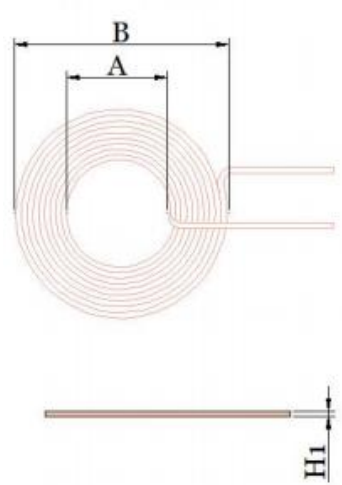

Figure 2: Hard disk

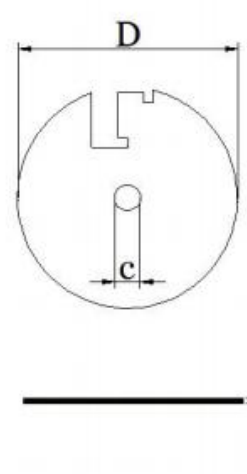
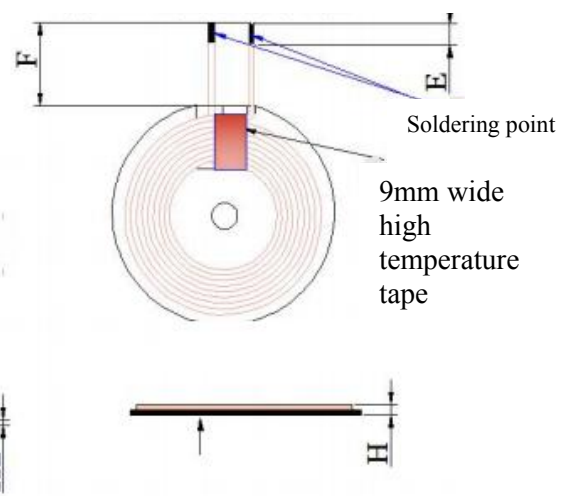

Figure 3: Coil and Magnetic Sheet Combination



Note:

- The coil is wound according to figure 1, the lead is crossed, and the coil is 9MM wide high temperature tape in the middle
- Magnetic chip specifications: 43.5 \* 5.3 \* 1.0 hard magnetic, Magnetic chip must not exceed 43.5
- Coil fitting magnetic field is shown in Figure 3 on the front fitting magnetic sheet, and the center requirement  $\leq 0.8$

二、原理图 SCHEMATIC DIAGRAM:



三、绕线参数 Winding Specification:

序号 NO	端子 TERMINAL		线径 WIRE	线材分解温度 Temperature	圈数 Turns	绕线方向 Winding Direction
L1	S	F	Silk-covered wire 0.07*100P	180-250 度	11TS	CCW

四、电气特性 ELECTRICAL CHARACTERISTIC: :

温度 TEMPERATURE: 25±10°C, 湿度 RELATIVE HUMIDITY: 65±20%  
测试仪器 TEST EQUIPMENTS: LCR Tester U2832

序号 NO	磁片材质 Disk material	电感量 LS	阻抗 DCR	测试条件 TEST FREQUENC	测试仪器 TEST EQUIPMENTS
L1		3.8uH±10% (unicoil)	50mΩ ±10%	100KHz/1.0V	U2832
L2	hard magnetic sheet	6.5-6.8uH±10% (Fit the magnetic sheet)	50mΩ ±10%	100KHz/1.0V	U2832

产品规格书 SPECIFICATION		Version A/0	PREPARED BY: Xiong Gang 2023/6/20	CHECKED BY: Frank Gao 2023/6/20
Drawing No: LCX-GCQP000957		Page No: 4/4	客户代码: CUST CODE	KH187
Specification	Ø19*35.5-0.32*2P-12TS-15-38RC	客户料号: CUST P/N		Receiving Coil
		内部料号: IN P/N		LXC-KH187003

五、包装方式 Packing way: Foam box packaging

