



## FCC TEST REPORT

**FCC ID: 2BHBG-WTU-02**

On Behalf of

Shenzhen Engete Electronic Technology Co., Ltd.

wireless microphone transmitter

Model No.: WTU-02, WTU-03, E208, E209, WTU-04, WTU-05,  
WTU-06

Prepared for : Shenzhen Engete Electronic Technology Co., Ltd.  
Address : E207, Hedong Building, Haoyunlai Plaza, Baoan District 80, Hedong  
Community, Xixiang Street, Baoan District, Shenzhen City

Prepared By : Shenzhen PSI Testing Co., Ltd.  
Address : 1-2/F., Building 5, Yudafu Industrial Park, No.10, Xingye West Road,  
Shajing Subdistrict, Bao'an District, Shenzhen, Guangdong, China

Report Number : psi2405049-C01-R01  
Date of Receipt : May 15, 2024  
Date of Test : May 15, 2024- June 17, 2024  
Date of Report : June 18, 2024  
Version Number : V0

## TABLE OF CONTENTS

<u>Description</u>	<u>Page</u>
<b>1. Summary Of Standards And Results</b> -----	<b>5</b>
1.1. Description of Standards and Results -----	5
<b>2. General Information</b> -----	<b>6</b>
2.1. Description of Device (EUT) -----	6
2.2. Accessories of Device (EUT) -----	7
2.3. Tested Supporting System Details-----	7
2.4. Block Diagram of Connection Between EUT and Simulators -----	7
2.5. Test Mode Description-----	8
2.6. Test Conditions-----	9
2.7. Test Facility-----	9
2.8. Measurement Uncertainty -----	9
2.9. Test Equipment List -----	10
<b>3. Spurious Emission</b> -----	<b>11</b>
3.1. Test Limits -----	11
3.2. Test setup-----	11
3.3. Test Procedure -----	12
3.4. Test Results -----	13
<b>4. Power Line Conducted Emission</b> -----	<b>19</b>
4.1. Test Limits -----	19
4.2. Test Procedure -----	19
4.3. Test Setup -----	19
4.4. Test Results -----	20
<b>5. Conducted Maximum Output Power</b> -----	<b>23</b>
5.1. Test limits -----	23
5.2. Test Procedure -----	23
5.3. Test Setup -----	23
5.4. Test Results -----	23
<b>6. Bandwidth</b> -----	<b>24</b>
6.1. Test limits -----	24
6.2. Test Procedure -----	24
6.3. Test Setup -----	24
6.4. Test Results -----	24
<b>7. Necessary Bandwith Test</b> -----	<b>27</b>
7.1. Test Setup -----	27
7.2. Test Limit-----	27
7.3. Test Procedure -----	28
7.4. Test Results -----	28
<b>8. Frequency stability</b> -----	<b>29</b>
8.1. Test limit-----	29
8.2. Test Procedure -----	29
8.3. Test Setup -----	29
8.4. Test Results -----	29
<b>9. Antenna Requirement</b> -----	<b>31</b>
9.1. Standard Requirement -----	31
9.2. Antenna Connected Construction -----	31
9.3. Results -----	31
<b>10. Photos of test setup</b> -----	<b>32</b>
<b>11. Photos of EUT</b> -----	<b>32</b>

## TEST REPORT DECLARATION

Applicant : Shenzhen Engete Electronic Technology Co., Ltd.

Address : E207, Hedong Building, Haoyunlai Plaza, Baoan District 80, Hedong Community,  
Xixiang Street, Baoan District, Shenzhen City

Manufacturer : Shenzhen Engete Electronic Technology Co., Ltd.

Address : E207, Hedong Building, Haoyunlai Plaza, Baoan District 80, Hedong Community,  
Xixiang Street, Baoan District, Shenzhen City

EUT Description : wireless microphone transmitter

(A) Model No. : WTU-02, WTU-03, E208, E209, WTU-04, WTU-05,  
WTU-06

(B) Trademark : BOMGE

Measurement Standard Used:

**FCC Rules and Regulations Part 15 Subpart C Section 15.236**

**ANSI C63.10-2013**

The device described above is tested by Shenzhen PSI Testing Co., Ltd. to determine the maximum emission levels emanating from the device and the severe levels of the device can endure and its performance criterion. The test results are contained in this test report and Shenzhen PSI Testing Co., Ltd. is assumed full responsibility for the accuracy and completeness of test. Also, this report shows that the EUT is technically compliant with the FCC Part 15 requirements.

This report applies to above tested sample only. This report shall not be reproduced in parts without written approval of Shenzhen PSI Testing Co., Ltd.

Tested by (name + signature).....: Felix Pang  
Test Engineer 

Approved by (name + signature).....: Simple Guan  
Project Manager 

Date of issue.....: June 18, 2024

### Revision History

Revision	Issue Date	Revisions	Revised By
V0	June 18, 2024	Initial released Issue	Felix Pang



# 1. Summary Of Standards And Results

## 1.1. Description of Standards and Results

The EUT have been tested according to the applicable standards as referenced below:

Test Item	Standards Paragraph	Result
Maximum Radiated Power	FCC Part 15.236(d)	P
Occupied Bandwidth	FCC Part 15.236(f)(2)	P
Necessary bandwidth	FCC Part 15.236(g)	P
Frequency stability	FCC Part 15.236(f)(3)	P
Emission within the band and outside this band	FCC Part 15.236(g)	P
Conducted Emission	FCC Part 207(a)	P
Antenna Requirement	FCC Part 15.203	P
<p>Note: 1. P is an abbreviation for Pass.            2. F is an abbreviation for Fail.            3. N/A is an abbreviation for Not Applicable.            4. Conclusion determination rules of this report: Unless there are clear provisions on measurement uncertainty in the standard or customer requirements, decision by actual test data without considering measurement uncertainty.</p>		

## 2. General Information

### 2.1. Description of Device (EUT)

Product Name	:	wireless microphone transmitter
Model Number	:	WTU-02, WTU-03, E208, E209, WTU-04, WTU-05, WTU-06
Diff	:	There is no difference except the name of the model. All tests are made with the WTU-02 model.
Power supply	:	DC 3.7 V from battery, DC 5V from Type-C
Radio Technology	:	Wireless Microphone
Operation frequency	:	550.3MHz-565.3MHz
Modulation type	:	FM
Channel No.	:	16 Channels
Antenna Type	:	Internal Antenna, max gain -2.71dBi.
Software version	:	V1.0
Hardware version/FVIN	:	V1.0
Note	:	Antenna information is provided by applicant. Testing lab is not responsible for the accuracy of the information.

## 2.2. Accessories of Device (EUT)

Accessories : N/A  
 Manufacturer : N/A  
 Model : N/A  
 Ratings : N/A

## 2.3. Tested Supporting System Details

No.	Description	Manufacturer	Model	Serial Number
1	Adapter	Keyulong	KE020A-PCD	N/A
2.	USB cable	N/A	N/A	N/A

## 2.4. Block Diagram of Connection Between EUT and Simulators

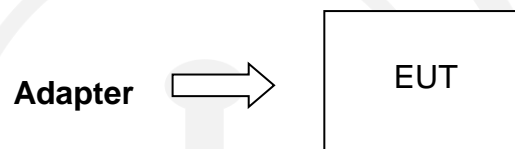

Signal Cable Description of the above Support Units

No.	Port Name	Cable	Length	Shielded (Yes or No)	Detachable (Yes or No)
(a)	Type-C	USB	1.0m	No	No

## 2.5. Test Mode Description

The test software was used to control EUT work in Continuous TX mode, and select test channel, wireless mode

Tested mode, channel information		
Mode	Channel	Frequency (MHz)
FM	CH1	550.3
	CH8	557.2
	CH16	565.3
Charging Mode		

Channel List					
Channel	Frequency(MHz)	Channel	Frequency(MHz)	Channel	Frequency(MHz)
1	550.3	9	558.3	/	/
2	551.3	10	559.3		
3	552.3	11	560.3		
4	553.3	12	561.3		
5	554.3	13	562.3		
6	555.3	14	563.3		
7	556.3	15	564.3		
8	557.3	16	565.3		



## 2.6. Test Conditions

Items	Required
Temperature range:	15-35°C
Humidity range:	25-75%
Pressure range:	86-106kPa

## 2.7. Test Facility

Shenzhen PSI Testing Co., Ltd.

1-2/F., Building 5, Yudafu Industrial Park, No.10, Xingye West Road, Shajing Subdistrict, Bao'an District, Shenzhen, Guangdong, China

September 13, 2023 File on Federal Communication Commission  
Registration Number: 916281

## 2.8. Measurement Uncertainty

(95% confidence levels, k=2)

Item	Uncertainty
Uncertainty for Power point Conducted Emissions Test	2.17dB
Uncertainty for Radiation Emission test in 3m chamber (below 30MHz)	3.5dB
Uncertainty for Radiation Emission test in 3m chamber (30MHz to 1GHz)	2.74dB(Polarize: V)
	2.76dB(Polarize: H)
Uncertainty for Radiation Emission test in 3m chamber (1GHz to 18GHz)	4.29dB(Polarize: V)
	4.82dB(Polarize: H)
Uncertainty for Radiation Emission test in 3m chamber (18GHz to 40GHz)	4.31dB(Polarize: V)
	4.30dB(Polarize: H)
Uncertainty for radio frequency	48.24KHz
Uncertainty for conducted RF Power	0.41dB
Uncertainty for Power Spectral Density	0.39 dB

## 2.9. Test Equipment List

Item	Equipment	Manufacturer	Model No.	Serial No.	Firmware Version	Last Cal.	Cal. Interval
1.	9*6*6 anechoic chamber	SKET	9*6*6	N/A	/	2022.12.20	3 Year
2.	Test Receiver	Rohde&Schwarz	ESCI 7	101032/003	4.42 SP3	2023.12.19	1 Year
3.	L.I.S.N.#1	Rohde&Schwarz	ENV216	102282	/	2023.12.19	1 Year
4.	L.I.S.N.#2	RFT	NNB111	13835240	/	2023.12.19	1 Year
5.	Loop Antenna	Schwarz beck	FMZB 1519B	00128	/	2023.04.03	2 Year
6.	Bilog Antenna	Schwarz beck	VULB 9168	01448	/	2022.12.26	2 Year
7.	Spectrum Analyzer	Rohde&Schwarz	FSV-40N	101648	3.70	2023.12.19	1 Year
8.	Horn Antenna	Schwarz beck	BBHA 9120 D	02706	/	2022.12.26	2 Year
9.	Amplifier	SKET	LAPA_01G1 8G-45dB	SK20220329 01	/	2023.12.19	1 Year
10.	Horn Antenna	Schwarz beck	BBHA 9170	00946	/	2022.12.25	2 Year
11.	Amplifier	SKET	LNPA_0118 G-45	SK20200108 01	/	2023.12.19	1 Year
12.	RF Power Probe	Rohde&Schwarz	NRP-Z11	1138.3004.02 -1111533-Fz	/	2023.12.19	1 Year
13.	RF Sensor Unit	Tachoy	TR1029-2	20220428P0 08	/	2023.12.19	1 Year
14.	Spectrum Analyzer	Agilent	N9020A	MY51281067	A.14.03	2023.12.19	1 Year
15.	Temp. & Humid Chamber	Auchno	9606	/	/	2023.12.19	1 Year
16.	Regulated DC Power Supply	Xinouhua	ADC120V10 A	2022112516 38		2023.12.19	1 Year
For Test Software Information							
Item	Software Name	Manufacturer			Version		
RE	EZ_EMG	Farad			PSI-3A1		
CE	EZ_EMG	Farad			PSI-3A1		
RF	RTS	TACHOY			V1.0.0		

### 3. Spurious Emission

#### 3.1. Test Limits

Spurious emissions are emissions outside the frequency range(s) of the equipment.

The power of the spurious emissions shall not exceed the limits of table as below:

State	Frequency		
	47 MHz to 74 MHz 87,5 MHz to 137 MHz 174 MHz to 230 MHz 470 MHz to 862 MHz	Other Frequencies below 1 000 MHz	Frequencies above 1 000 MHz
Operation	4 nW	250 nW	1 $\mu$ W
Standby	2 nW	2 nW	20 nW

#### 3.2. Test setup

##### 3.2.1 In 3m Anechoic Chamber Test Setup Diagram for below 30MHz

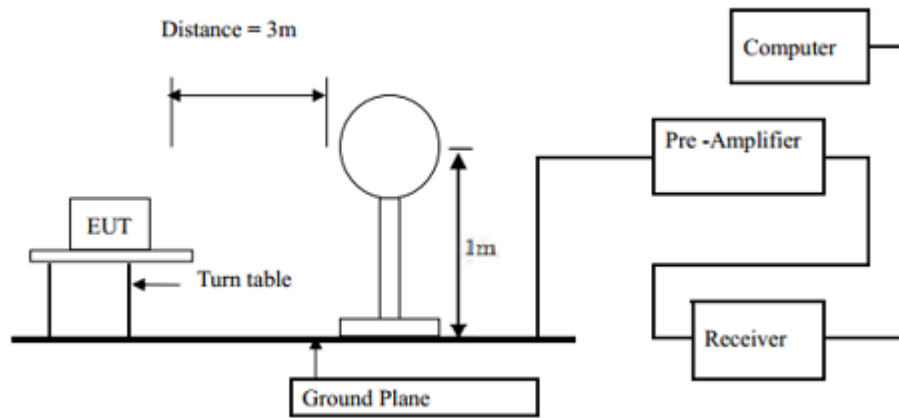

##### 3.2.2 In 3m Anechoic Chamber Test Setup Diagram for below 1GHz

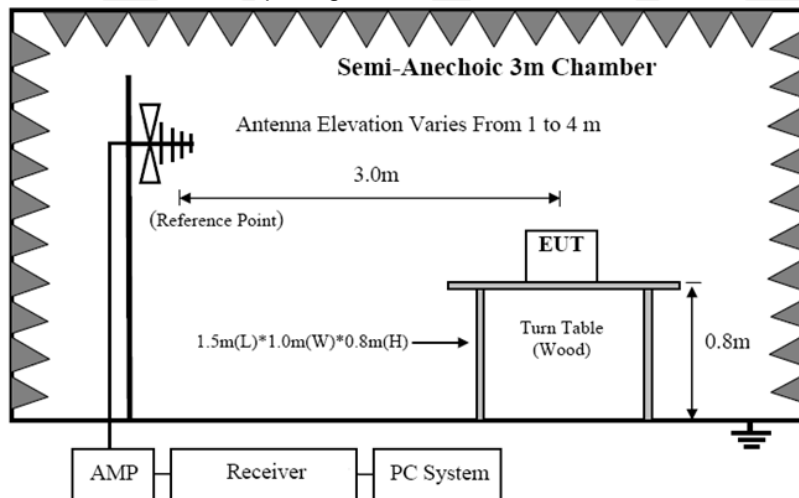

##### 3.2.3 In 3m Anechoic Chamber Test Setup Diagram for frequency above 1GHz

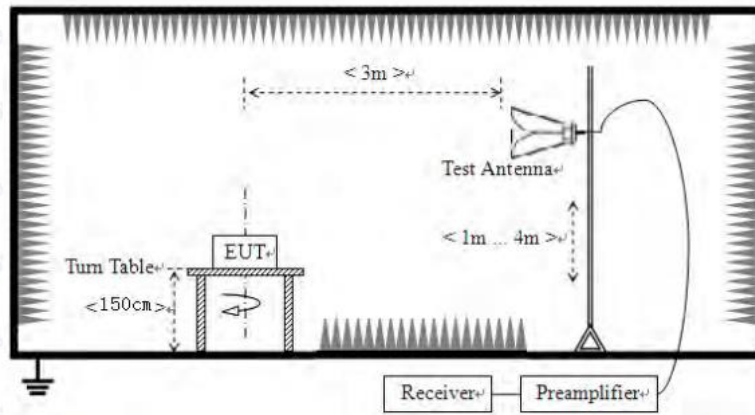

### 3.3. Test Procedure

1. The measuring receiver, as defined in table 4, shall be tuned over the frequency range 25 MHz to 4 GHz for equipment operating on frequencies below 1 GHz or in the frequency range of 25 MHz to 12,75 GHz for equipment operating on frequencies above 1 GHz.
2. Please refer to ETSI EN 300 422-1 V1.4.2 (2011-08) clause 6.1 for the test conditions.
3. Please refer to ETSI EN 300 422-1 V1.4.2 (2011-08) clause 8.4.2 for the measurement method.

**Table 4: Reference bandwidth**

Frequency being measured	Measuring receiver bandwidth
25 MHz to 30 MHz	9 kHz to 10 kHz
30 MHz to 1 000 MHz	100 kHz to 120 kHz
> 1 000 MHz	1 MHz

### 3.4. Test Results

From 25MHz to 30MHz:	
Test Date : 2024.05.24	Temperature : 26°C
Test Engineer : Felix Pang	Humidity : 54%
Test Mode : FM mode	
Test Results : <b>PASS</b>	
Note:	The amplitude of spurious emissions which are attenuated by more than 20dB below the permissible value has no need to be reported.



From 30MHz to 1000MHz:	
Test Date : 2024.05.24	Temperature : 26°C
Test Engineer : Felix Pang	Humidity : 54%
Test Mode : GFSK mode	
Test Results : <b>PASS</b>	
Note:	<ol style="list-style-type: none"><li>1. The test results are listed in next pages.</li><li>2. If the limits for the measurement with the average detector are met when using a receiver with a peak detector, the test unit shall be deemed to meet both limits and the measurement with the average detector and quasi-peak detector need not be carried out.</li><li>3. All modes have been tested, and only worst data of FM 550.3MHz mode was listed in this report.</li></ol>



## Polarization: Vertical

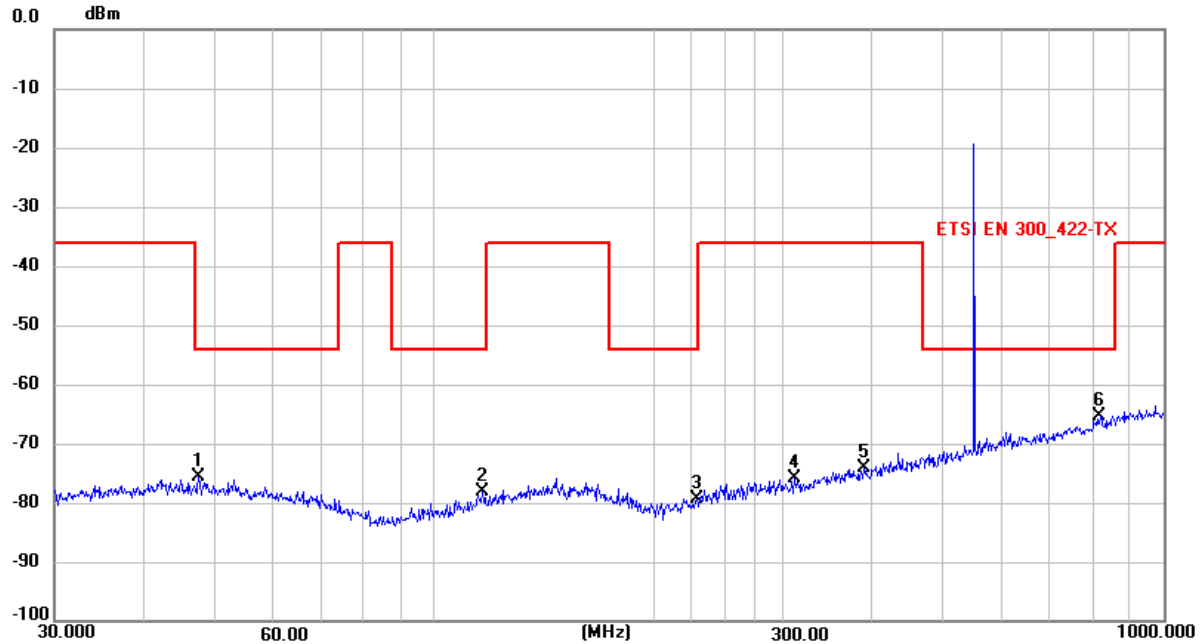

No.	Frequency (MHz)	Reading (dBm)	Factor (dB)	Level (dBm)	Limit (dBm)	Margin (dB)	Detector
1	47.3463	-88.87	13.32	-75.55	-54.00	-21.55	peak
2	116.1321	-89.12	11.10	-78.02	-54.00	-24.02	peak
3	228.4904	-90.71	11.27	-79.44	-54.00	-25.44	peak
4	311.9057	-89.73	13.97	-75.76	-36.00	-39.76	peak
5	388.6728	-89.96	15.91	-74.05	-36.00	-38.05	peak
6 *	821.7103	-89.01	23.76	-65.25	-54.00	-11.25	peak

Level = Reading + Factor Margin = Level - Limit

Polarization: Horizontal

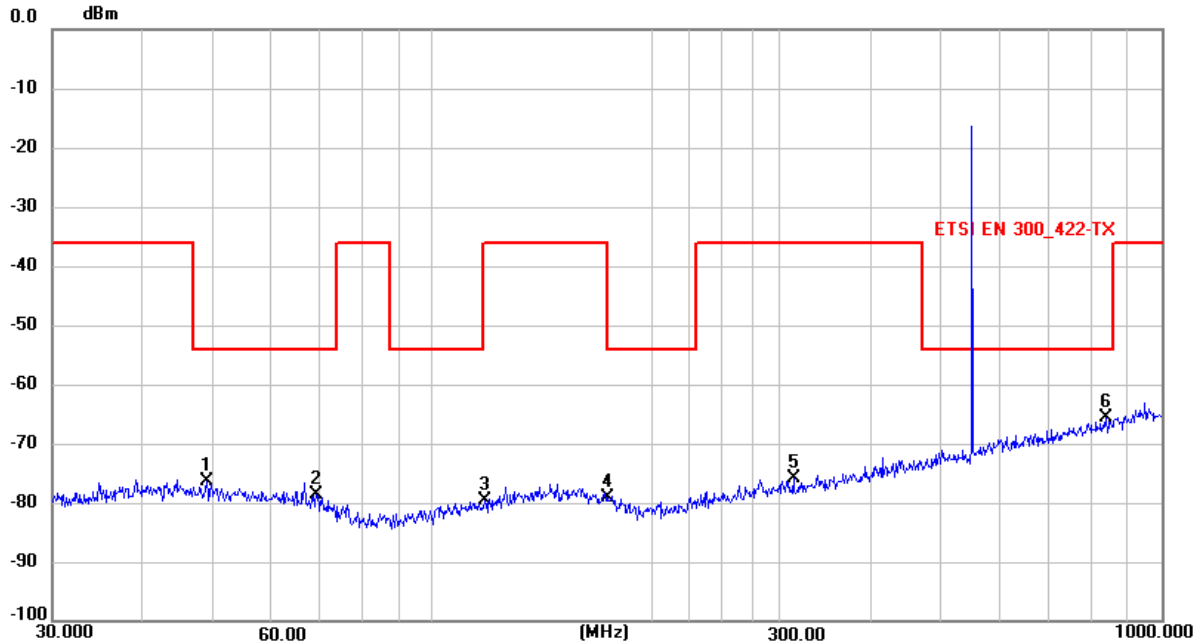

No.	Frequency (MHz)	Reading (dBm)	Factor (dB)	Level (dBm)	Limit (dBm)	Margin (dB)	Detector
1	48.9501	-89.65	13.24	-76.41	-54.00	-22.41	peak
2	69.2961	-89.81	11.17	-78.64	-54.00	-24.64	peak
3	118.1342	-90.81	11.30	-79.51	-36.00	-43.51	peak
4	174.1948	-90.89	11.86	-79.03	-54.00	-25.03	peak
5	312.3163	-89.76	13.98	-75.78	-36.00	-39.78	peak
6 *	842.1296	-89.67	24.04	-65.63	-54.00	-11.63	peak

Level = Reading + Factor Margin = Level - Limit



From 1GHz to 4GHz:	
Test Date : 2024.05.24	Temperature : 26°C
Test Engineer : Felix Pang	Humidity : 54%
Test Mode : FM mode	
Test Results : <b>PASS</b>	
Note:	<ol style="list-style-type: none"><li>1. The test results are listed in next pages.</li><li>2. If the limits for the measurement with the average detector are met when using a receiver with a peak detector, the test unit shall be deemed to meet both limits and the measurement with the average detector and quasi-peak detector need not be carried out.</li><li>3. If the limits for the measurement with the average detector are met when using a receiver with a quasi-peak detector, the test unit shall be deemed to meet both limits and the measurement with the average detector need not be carried out.</li></ol>



Test Mode: CH1 550.3MHz					
Frequency (MHz)	Antenna polarization	Result (dBm)	Limit (dBm)	Margin (dB)	Conclusion
1100.6	H	-43.54	-30	-13.54	Pass
1650.9	H	-39.74	-30	-9.74	Pass
1100.6	V	-41.42	-30	-11.42	Pass
1650.9	V	-42.13	-30	-12.13	Pass
Test Mode: CH8 557.3MHz					
Frequency (MHz)	Antenna polarization	Result (dBm)	Limit (dBm)	Margin (dB)	Conclusion
1114.6	H	-43.95	-30	-13.95	Pass
1671.9	H	-39.89	-30	-9.89	Pass
1114.6	V	-41.47	-30	-11.47	Pass
1671.9	V	-41.9	-30	-11.9	Pass
Test Mode: CH16 565.3MHz					
1130.6	H	-43.94	-30	-13.94	Pass
1695.9	H	-39.86	-30	-9.86	Pass
1130.6	V	-41.07	-30	-11.07	Pass
1695.9	V	-41.99	-30	-11.99	Pass
<p>Note: 1. Means other frequency and mode comply with standard requirements and at least have 20dB margin.</p> <p>2. Correct Factor=Cable Loss+ Antenna Factor-Amplifier Gain.  Result=Reading + Correct Factor. Margin= Result-Limit.</p>					

## 4. Power Line Conducted Emission

### 4.1. Test Limits

Frequency MHz	Limits dB( $\mu$ V)	
	Quasi-peak Level	Average Level
0.15 -0.50	66 -56*	56 - 46*
0.50 -5.00	56	46
5.00 -30.00	60	50

Notes: 1. \*Decreasing linearly with logarithm of frequency.

2. The lower limit shall apply at the transition frequencies.

3. The limit decreases in line with the logarithm of the frequency in the range of 0.15 to 0.50 MHz.

### 4.2. Test Procedure

The EUT is put on the plane 0.8m high above the ground by insulating support and is connected to the power mains through a line impedance stabilization network (L.I.S.N.). This provides a 50ohm coupling impedance for the EUT system. Please refer the block diagram of the test setup and photographs.

Both sides of AC lines are checked to find out the maximum conducted emission. In order to find the maximum emission levels, the relative positions of equipment and all of the interface cables shall be changed according to ANSI C63.10:2013 on Conducted Emission Measurement.

The bandwidth of test receiver is set at 9 kHz.

### 4.3. Test Setup

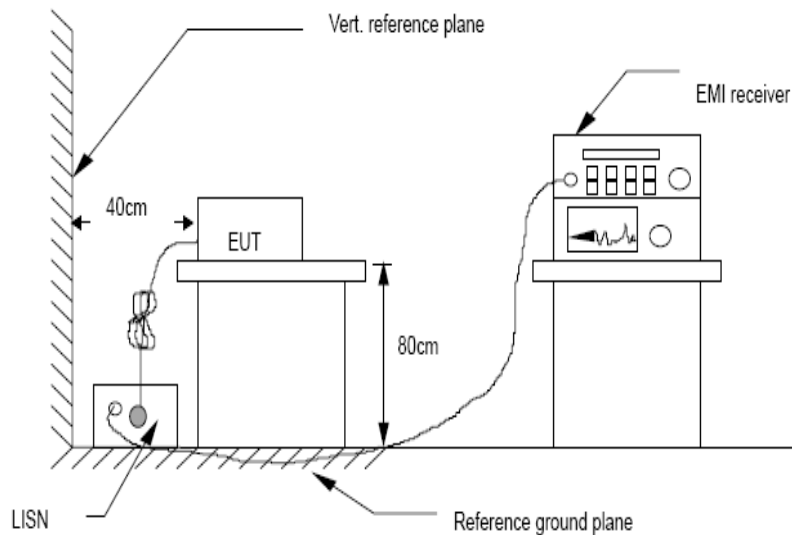

#### 4.4. Test Results

Test Date	: 2024.05.20	Temperature	: 26°C
Test Engineer	: Felix Pang	Humidity	: 54%
Test Mode	: Charging		
Test Results	: <b>PASS</b>		
Note:	<ol style="list-style-type: none"><li>1. The test results are listed in next pages.</li><li>2. If the limits for the measurement with the average detector are met when using a receiver with a peak detector, the test unit shall be deemed to meet both limits and the measurement with the average detector and quasi-peak detector need not be carried out.</li><li>3. If the limits for the measurement with the average detector are met when using a receiver with a quasi-peak detector, the test unit shall be deemed to meet both limits and the measurement with the average detector need not be carried out.</li></ol>		

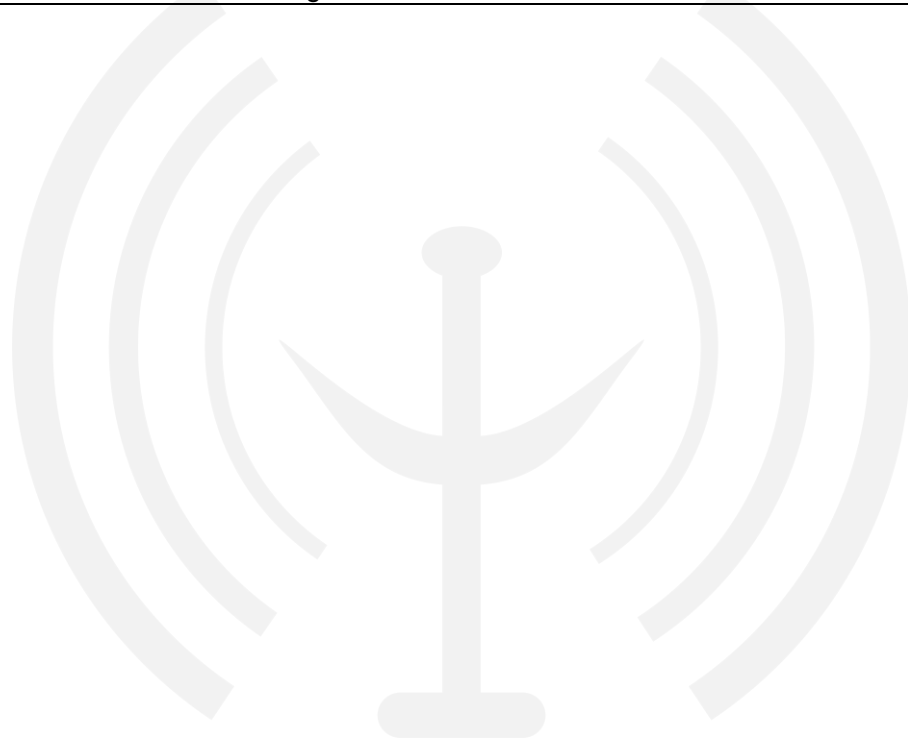

## Polarization: L

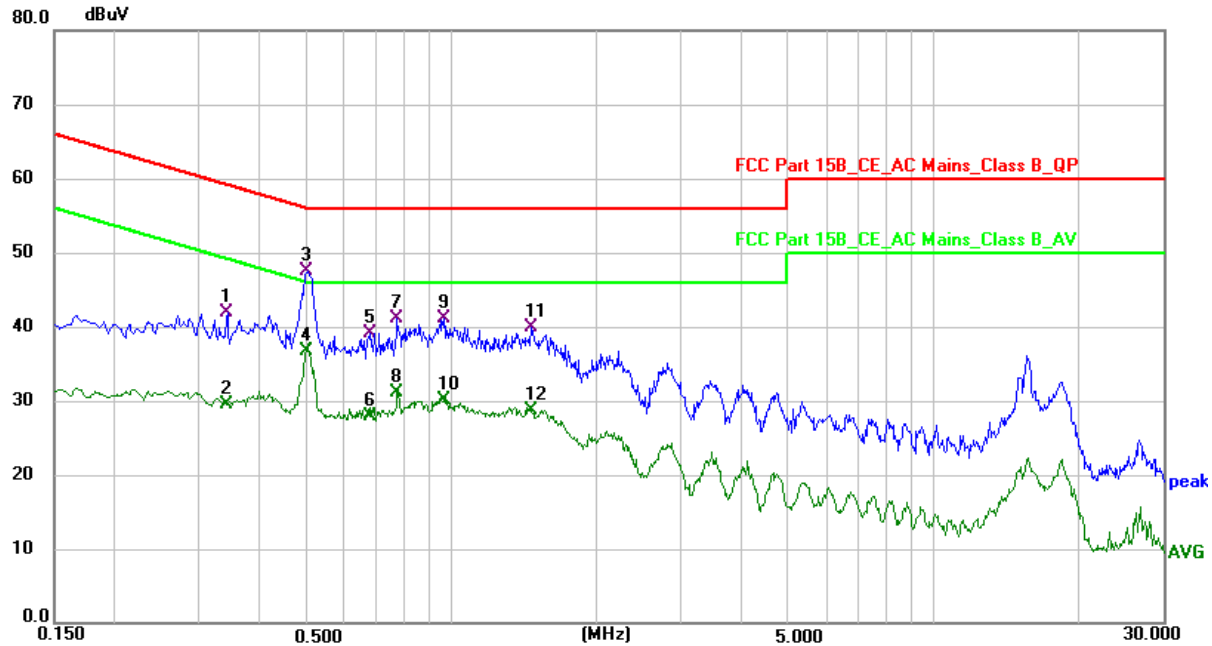

No.	Frequency (MHz)	Reading (dBuV)	Factor (dB)	Level (dBuV)	Limit (dBuV)	Margin (dB)	Detector	P/F
1	0.3420	32.00	9.83	41.83	59.15	-17.32	QP	P
2	0.3420	19.75	9.83	29.58	49.15	-19.57	AVG	P
3 *	0.5020	37.64	9.91	47.55	56.00	-8.45	QP	P
4	0.5020	26.84	9.91	36.75	46.00	-9.25	AVG	P
5	0.6820	29.71	9.47	39.18	56.00	-16.82	QP	P
6	0.6820	18.47	9.47	27.94	46.00	-18.06	AVG	P
7	0.7740	31.74	9.42	41.16	56.00	-14.84	QP	P
8	0.7740	21.73	9.42	31.15	46.00	-14.85	AVG	P
9	0.9660	31.75	9.41	41.16	56.00	-14.84	QP	P
10	0.9660	20.66	9.41	30.07	46.00	-15.93	AVG	P
11	1.4660	30.58	9.40	39.98	56.00	-16.02	QP	P
12	1.4660	19.39	9.40	28.79	46.00	-17.21	AVG	P

Note: Level = Reading + Factor Margin = Level - Limit

## Polarization: N

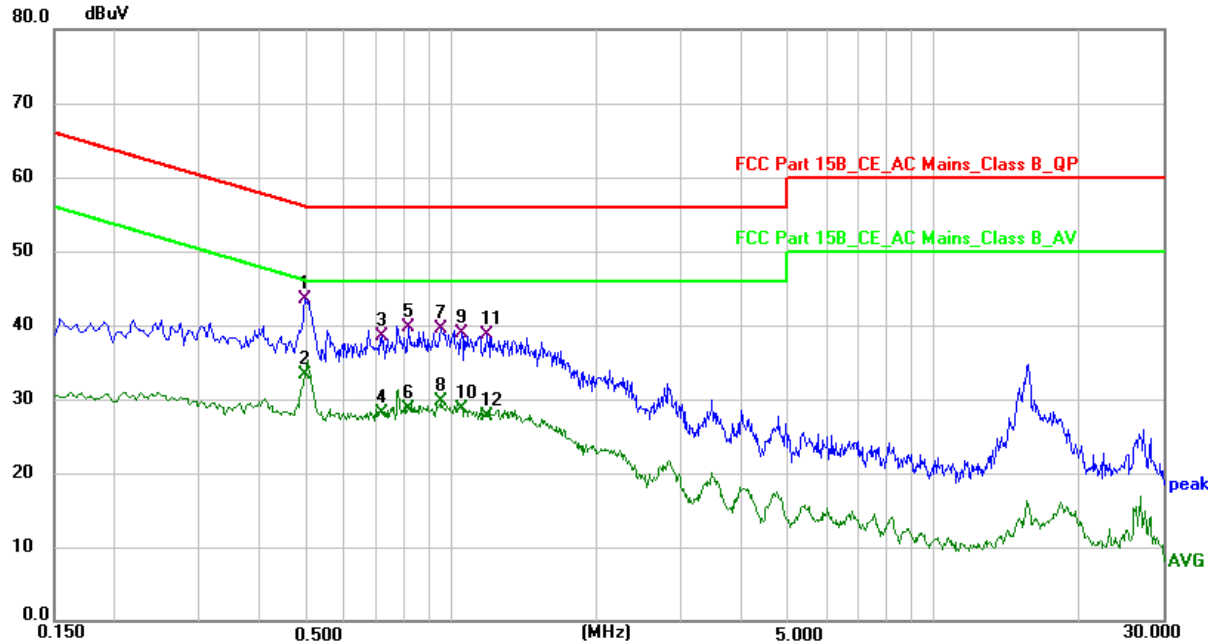

No.	Frequency (MHz)	Reading (dBuV)	Factor (dB)	Level (dBuV)	Limit (dBuV)	Margin (dB)	Detector	P/F
1 *	0.4980	33.73	9.78	43.51	56.03	-12.52	QP	P
2	0.4980	23.61	9.78	33.39	46.03	-12.64	AVG	P
3	0.7180	28.68	9.76	38.44	56.00	-17.56	QP	P
4	0.7180	18.33	9.76	28.09	46.00	-17.91	AVG	P
5	0.8139	30.03	9.68	39.71	56.00	-16.29	QP	P
6	0.8139	19.00	9.68	28.68	46.00	-17.32	AVG	P
7	0.9500	29.93	9.55	39.48	56.00	-16.52	QP	P
8	0.9500	20.17	9.55	29.72	46.00	-16.28	AVG	P
9	1.0540	29.36	9.50	38.86	56.00	-17.14	QP	P
10	1.0540	19.22	9.50	28.72	46.00	-17.28	AVG	P
11	1.1900	29.16	9.46	38.62	56.00	-17.38	QP	P
12	1.1900	18.33	9.46	27.79	46.00	-18.21	AVG	P

Note: Level = Reading + Factor Margin = Level - Limit

## 5. Conducted Maximum Output Power

### 5.1. Test limits

Refer to FCC 15.236(d) In the bands allocated and assigned for broadcast television and in the 600 MHz service band: 50 mW EIRP.

### 5.2. Test Procedure

Details see the KDB558074 D01 Meas Guidance v05r02

- (1) Place the EUT on the table and set it in transmitting mode.
- (2) Connected the EUT's antenna port to peak power meter by 20dB attenuator.
- (3) Measure out each mode and each bands peak output power of EUT.

Note: The cable loss and attenuator loss were offset into measure device as amplitude offset.

### 5.3. Test Setup

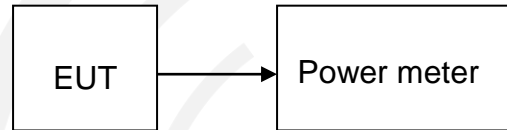

### 5.4. Test Results

Test mode	Channel	Frequency (MHz)	Peak Output Power (dBm)	Antenna Gain (dBi)	ERP (dBm)	Limit (dBm)	Verdict
FM	1	550.3	2.37	-2.71	-2.49	16.99	PASS
FM	8	557.3	<b>2.65</b>	-2.71	-2.21	16.99	PASS
FM	16	565.3	2.53	-2.71	-2.33	16.99	PASS

Note:  $ERP(dBm) = \text{Peak Output Power}(dBm) + \text{Antenna Gain}(dBi) - 2.15$

## 6. Bandwidth

### 6.1. Test limits

According to FCC 15.236(f)(2), The operating frequency within a permissible band of operation as defined in paragraph (c) must comply with the following requirements.

(1) The frequency selection shall be offset from the upper or lower band limits by 25 kHz or an integral multiple thereof.

(2) One or more adjacent 25 kHz segments within the assignable frequencies may be combined to form a channel whose maximum bandwidth shall not exceed 200 kHz. The operating bandwidth shall not exceed 200kHz.

Emissions within the band from one megahertz below to one megahertz above the carrier frequency shall comply with the emission mask in Section 8.3 of ETSI EN 300 422-1 V1.4.2 (2011-08) (incorporated by reference, see §15.38). Emissions outside this band shall comply with the limit specified at the edges of the ETSI mask.

### 6.2. Test Procedure

According to TIA-603 for additional Test Set-Up procedures, the occupied bandwidth of emission was measured with a Spectrum Analyzer connected to the antenna terminal while EUT was operating in 2.5kHz tone at an input level 16 dB greater than that necessary to produce 50 percent modulation. Then mark the -20dB Bandwidth and record it.

### 6.3. Test Setup

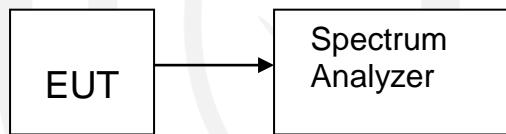

### 6.4. Test Results

Channel	Frequency (MHz)	99% BW(kHz)	-20dB BW(kHz)	limit(kHz)	Result
CH-1	550.3	64.936	65.50	200	Pass
CH-8	557.3	64.973	65.50	200	Pass
CH-16	565.3	64.892	65.43	200	Pass



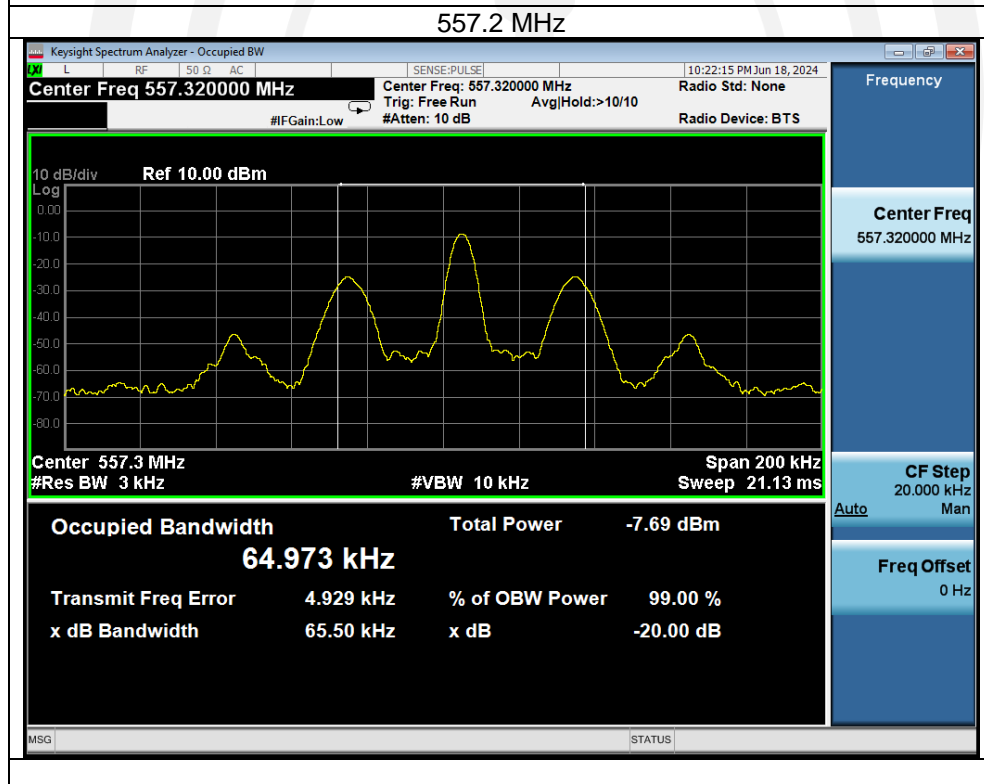
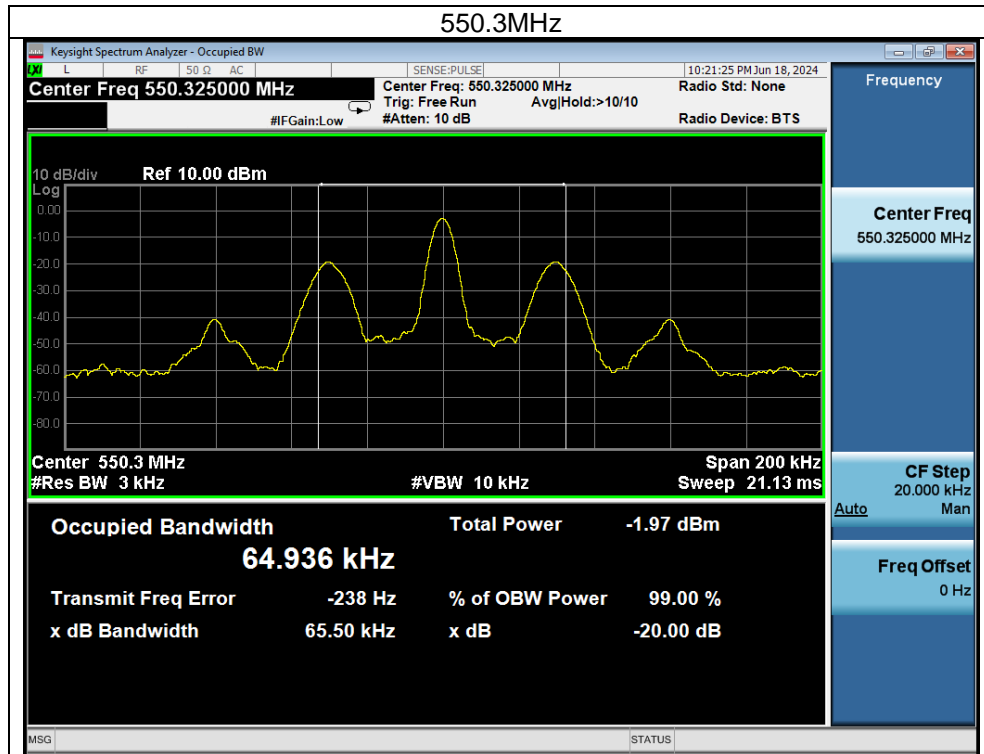

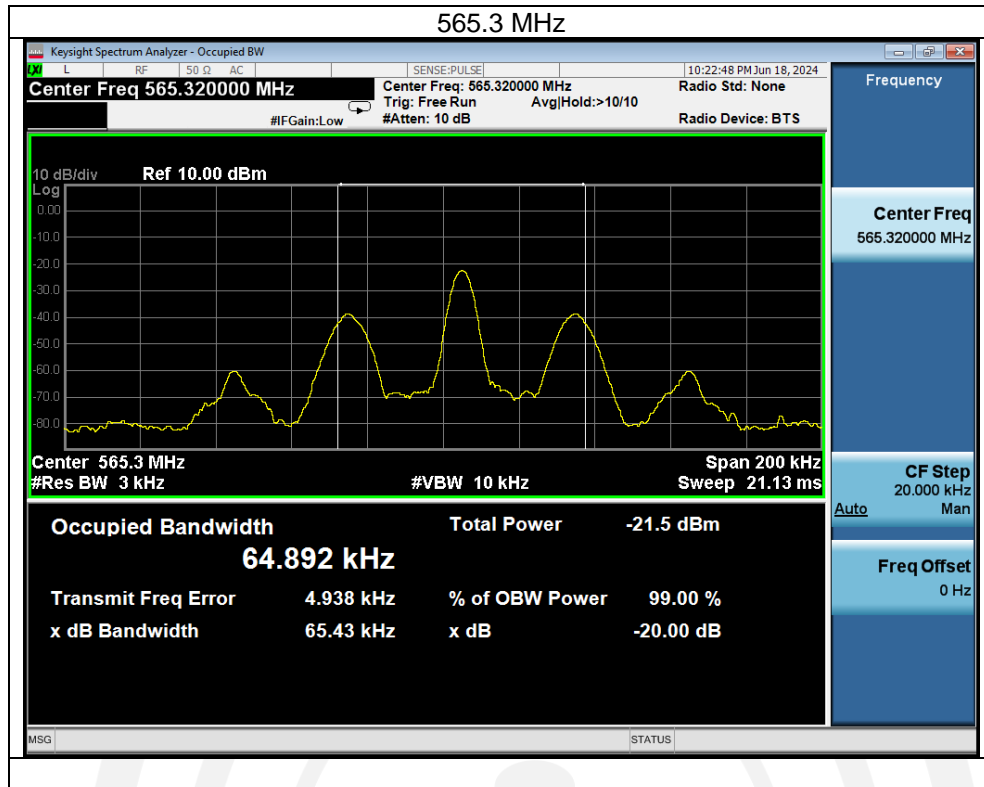

## 7. Necessary Bandwith Test

### 7.1. Test Setup

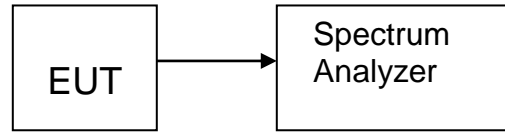

### 7.2. Test Limit

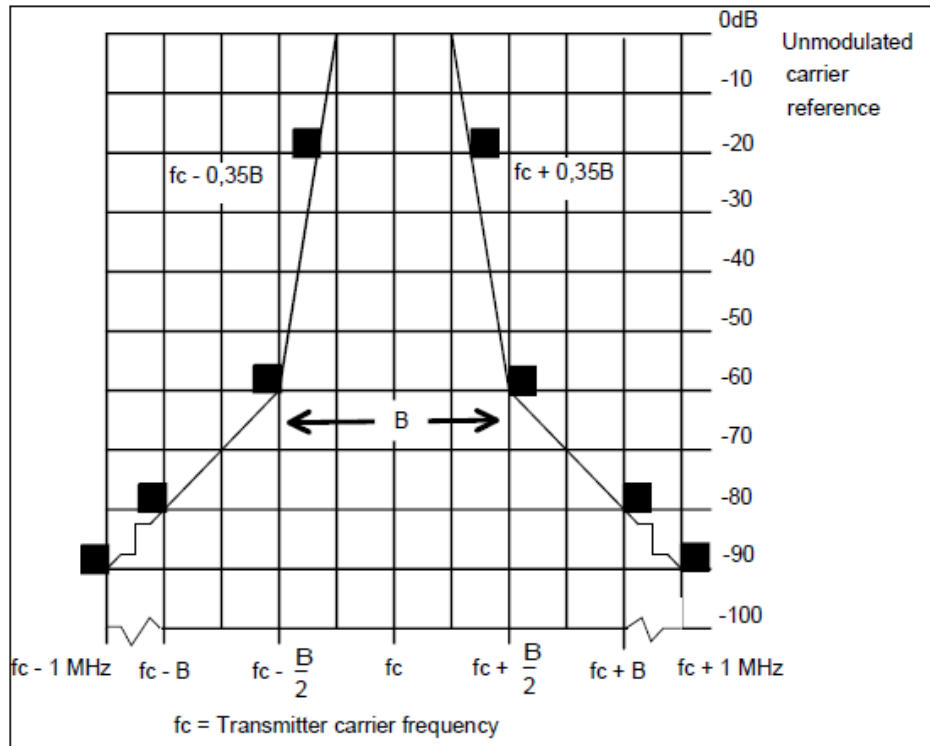

**Figure 3: Spectrum mask for analogue systems in all bands**

According to §15.236 (g) Emissions within the band from one megahertz below to one megahertz above the carrier frequency shall comply with the emission mask in §8.3 of ETSI EN 300 422-1 V1.4.2 (2011-08), Electromagnetic compatibility and Radio spectrum Matters (ERM); Wireless UHF Microphones in the 25 MHz to 3GHz frequency range; Part 1: Technical characteristics and methods of measurement. Emissions outside of this band shall comply with the limits specified in section 8.4 of ETSI EN 300 422-1 V1.4.2(2011-08).

According to ETSI EN 300 422-1 V1.4.2 section 8.3, the transmitter output spectrum shall be within the mask defined in the following figure.

### 7.3. Test Procedure

According to ETSI EN 300 422-2 V2.1.1 section 8.3

### 7.4. Test Results

Pass

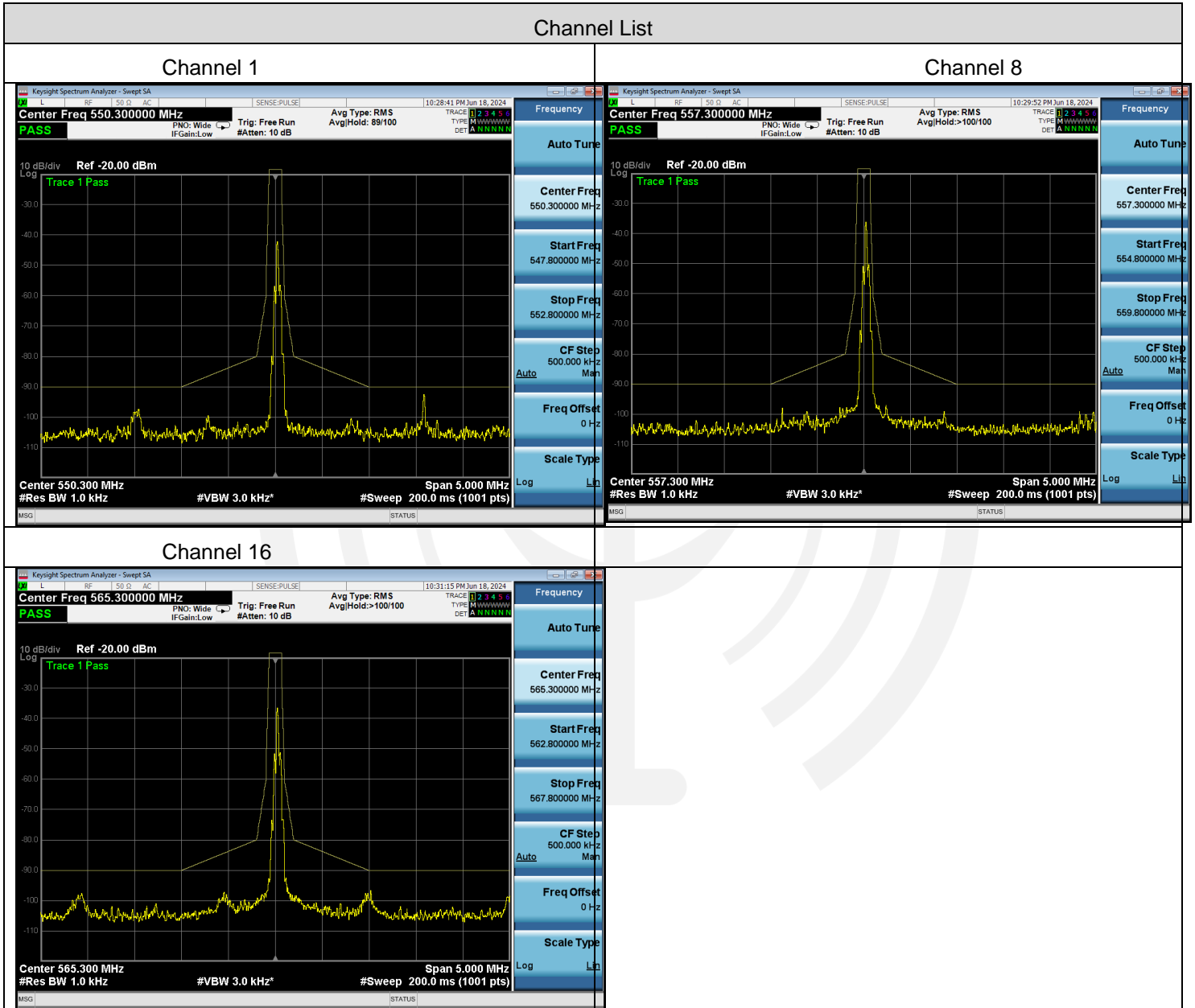

## 8. Frequency stability

### 8.1. Test limit

The frequency tolerance of the carrier signal shall be maintained within  $\pm 0.005\%$  of the operating frequency over a temperature variation of  $-20$  degrees to  $+50$  degrees C at normal supply voltage, and for a variation in the primary supply voltage from 85% to 115% of the rated supply voltage at a temperature of 20 degrees C

### 8.2. Test Procedure

- a. The EUT was connected to an external DC power supply and the RF output was connected to a frequency counter via feed through attenuators. The EUT was placed inside the temperature chamber. The DC leads and the RF output cable, exited the chamber through an opening made for that purpose. After the temperature stabilized the frequency output was recorded from the counter. An external variable DC power supply was connected to the battery terminals of the equipment under test.
- b. For hand carried, battery powered equipment primary supply voltage was reduced to the battery operating end point as specified by the manufacturer. The output frequency was recorded for each battery voltage.

### 8.3. Test Setup

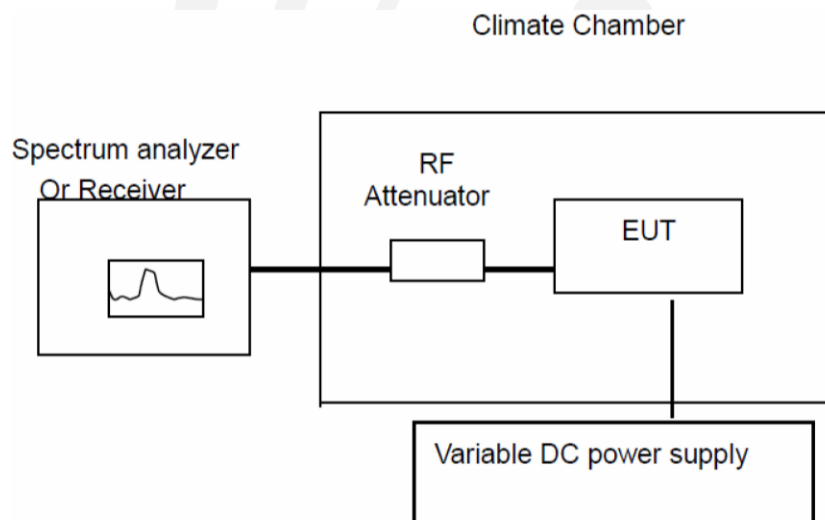

### 8.4. Test Results

#### **PASS.**

- (1) Frequency stability versus input voltage (Supply Nominal voltage is DC 3.7V)
- (2) Frequency stability versus input voltage (Supply battery operating end point which shall be specified by the manufacturer DC 3.7V)

Reference Frequency: 550.3 MHz			
Power supply	Environment Temperature(°C)	Frequency Error ( Hz )	Frequency Error (ppm)
DC3.3V	20	25100	45.61
DC 3.7V	20	25800	46.88
DC 4.2V	20	25700	46.70

Reference Frequency: 550.3 MHz				
Frequency Deviation measured with time Elapse(30 minutes)				
Environment Temperature(°C)	Frequency Error ( Hz )	Frequency Error (ppm)	Limit (ppm)	Results
50	25400	46.16	50	Pass
40	25400	46.16		
30	25600	46.52		
20	25100	45.61		
10	25400	46.16		
0	25200	45.79		
-10	25300	45.97		
-20	25200	45.79		

Note: The test results show the worst patterns.

## 9. Antenna Requirement

### 9.1. Standard Requirement

An intentional radiator shall be designed to ensure that no antenna other than that furnished by the responsible party shall be used with the device. The use of a permanently attached antenna or of an antenna that uses a unique coupling to the intentional radiator shall be considered sufficient to comply with the provisions of this Section. The manufacturer may design the unit so that a broken antenna can be replaced by the user, but the use of a standard antenna jack or electrical connector is prohibited.

### 9.2. Antenna Connected Construction

The antenna connector is unique antenna and no consideration of replacement. Please see EUT photo for details.

### 9.3. Results

The EUT antenna is internal antenna. It complies with the standard requirement.

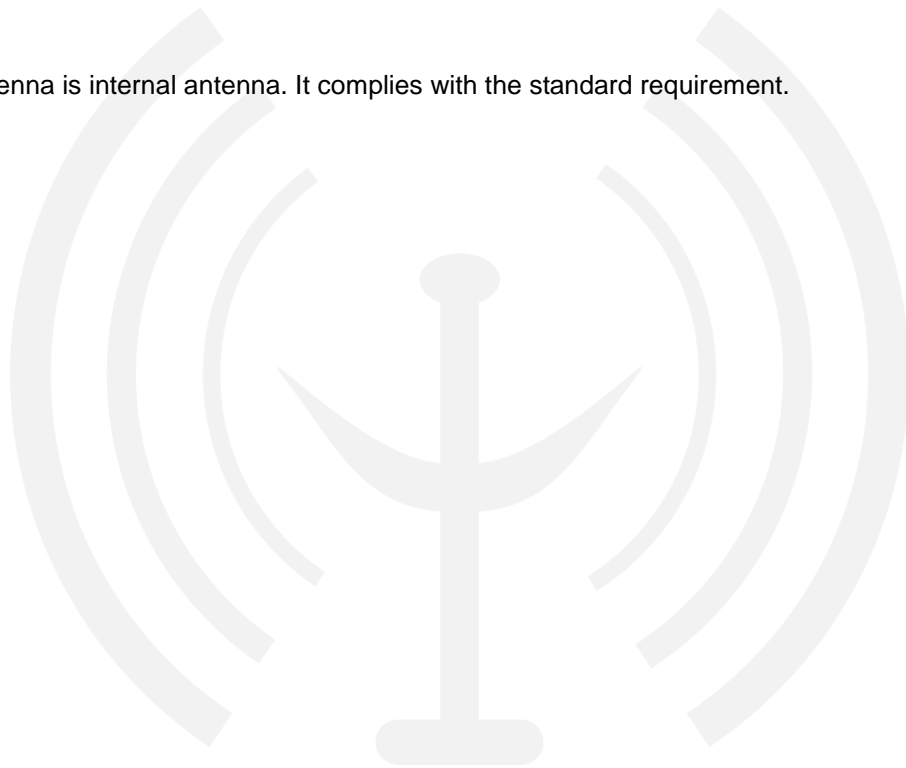

## 10. Photos of test setup

Reference to the **appendix I Test Setup Photo** for details.

## 11. Photos of EUT

Reference to the **appendix II external photos** and **appendix III internal photos** for details.

----- END OF REPORT-----

