

Magnetic Rowing Machine 5303D User Manual

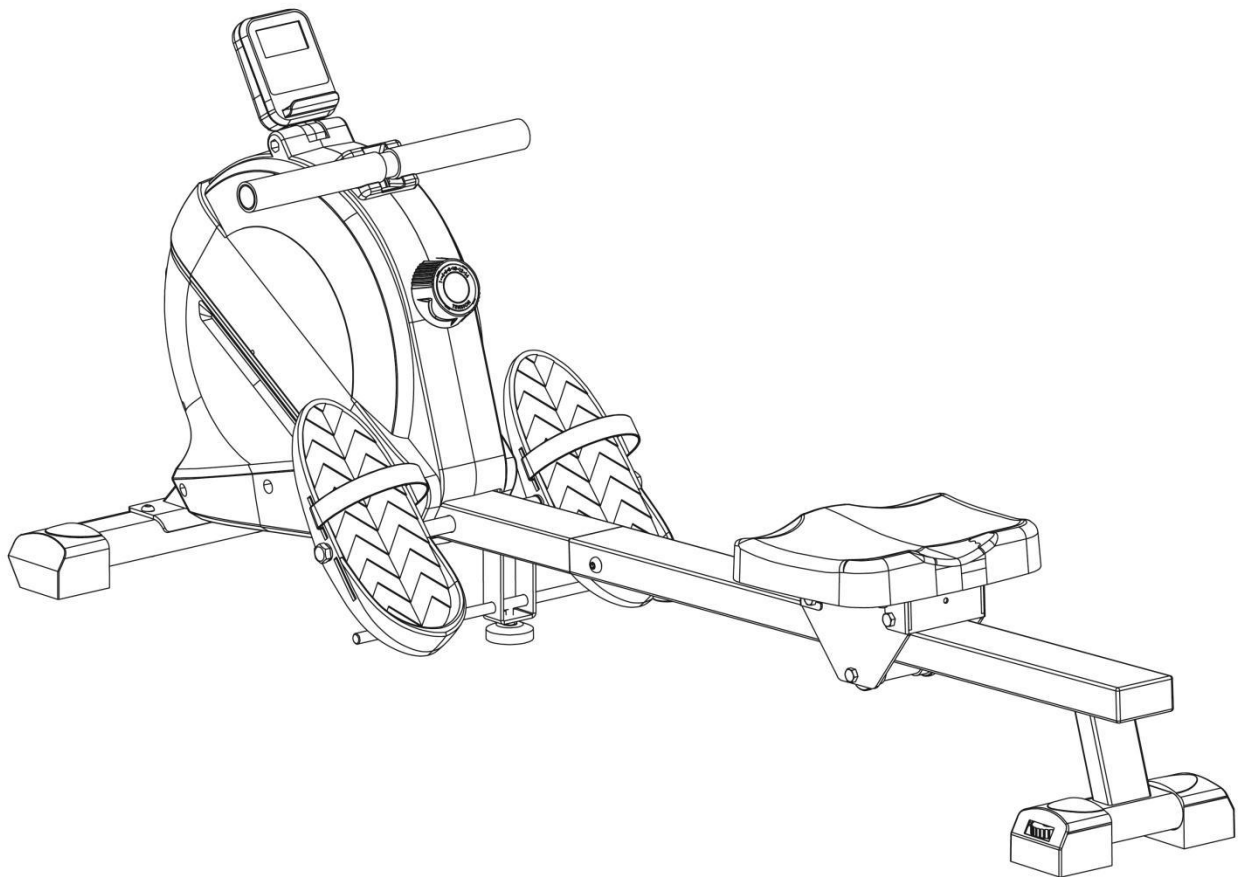

Notice! Please read this manual carefully before assembling and using this product; the product appearance is subject to the actual product and is subject to change without prior notice .

TABLE OF CONTENTS

Warranty Information & After-Sales Service	1
What You Need to Know about Safe Use	2
Product Specifications	6
Packing List	7
Product Exploded View	9
Parts List	10
Installation Steps	12
Features	18
Adjustment Guidelines	19

Warranty Information & After-Sales Service

Welcome to using Magnetic Rowing Machine series products. This product comes with 12 months FREE WARRANTY for normal use, provided that it is not damaged by human intervention. Please note that our company is not responsible for any failures caused by incorrect installation, incorrect use, or replacement of parts, and the warranty does not apply to unauthorized repairs, including resulting which are the responsibility of the customer.

Please note that this product is intended for home use only, and our company is not responsible for any problems caused by commercial use.

After-sales Service

If you encounter any product problems or have lost the remote control, please contact us through the following methods. We provide 24/7 customer service and support.

Hartwares Service Team contact information:

 **Service Email:** info@hartwaresport.com

 **WhatsApp QR code:**



What You Need to Know About Safe Use

Thank you for purchasing our products. Proper use of this equipment is a guarantee of your safety and health. It is very important to read the manual carefully before using this equipment! Exercise can only be safe and effective if this equipment is properly installed, maintained and used.

- 1.** During exercise, your hands should be firmly on the movable handlebars, and your feet should be placed on the foot pedals and tied tightly with straps.
- 2.** This equipment is only suitable for indoor and household use. The maximum user weight and load is 265LBS.
- 3.** This device is classified as HC and is not suitable for medical use.
- 4.** Before assembly, you need to fully understand and check the parts list provided with this equipment, and install it in full accordance with the instruction manual.
- 5.** Applicable tools must be used during installation. If necessary, ask a second person to assist you in the installation.
- 6.** Fitness equipment needs to be placed on a flat, non-slip floor. If placed in a humid space, the long-term use of the equipment will be affected by corrosion.
- 7.** Before use, please check whether each screw component is locked, and ensure that there is a 0.6-meter space around the equipment, and there should be no protruding adjustable devices.
- 8.** Only by regularly checking whether each connection part of the equipment is tight and in normal condition can the safety level of the equipment be ensured.
- 9.** Do not use corrosive cleaners during maintenance and cleaning to prevent liquid from entering the equipment through the tail or gaps.
- 10.** This equipment is for adults only. Children and pets should stay away from this equipment. It can only be operated under the guidance of adults.
- 11.** This equipment can only be used by one person at a time. Please point

out possible dangers to those around you, such as the dangers caused by moving parts during exercise.

12. Wear well-fitting clothing when exercising to prevent loose clothing from catching on equipment or restricting movement.

13. Please do not exercise before or after meals.

14. Please pay attention to the exercise methods and resistance adjustments in the instructions.

15. The resistance of this equipment has nothing to do with speed. The resistance has nothing to do with the rotation speed during the process of driving the equipment and remains constant.

16. Please consult your family doctor before exercising. He will tell you what kind of exercise and exercise load are suitable. Wrong exercise will damage your health. Overtraining can lead to serious injury or death. If you feel dizzy, please stop immediately. train.

17. The electronic watch has multiple function displays. It will reflect the corresponding values according to the different degrees of human movement. I would like to remind you that the heartbeat value of the electronic watch may be inaccurate and can only give you some refer to.

18. Please keep this manual and installation tools properly .

Important advice

1. Follow the installation instructions and use only the parts configured with this equipment.

2. In principle, we do not regard sports equipment as toys and can only be used by people who have relevant knowledge or have received guidance.

3. If you experience dizziness, nausea, chest pain, or other unusual symptoms, stop exercising immediately and consult your doctor.

4. People such as children and disabled people should only use this equipment under the guidance of a skilled person.

5. Please note that you and others must never put any part of your body into the sports area.
6. In the adjustable parts of the equipment, pay special attention to the marked maximum limit position.
7. Only regular inspections for wear and loose parts can ensure that the equipment is in high quality.

Assembly Instructions

1. The product must be installed carefully by an adult and in case of uncertainty ask for help from technically experienced personnel.
2. Unwrap all packaging materials and arrange the various components so that it is clearer and easier to understand for assembly. Use pads to protect the mounting surface from dirt or scratches.
3. Then check whether all components are complete according to the parts list, and the packaging materials can be discarded only after installation is completed.
4. Before starting assembly, please read the installation instructions carefully and understand the corresponding schematic diagram.
5. Please note that there is always a risk of injury when using tools and performing manual operations, so be careful when installing the product.
6. After assembling the product according to the instructions, please carefully check whether the screws, nuts, and knobs are installed correctly and tightened in place.
7. After installation, please do not place the tools randomly.
8. It is recommended that you find a protective pad (not included with the product) and place it under the product to protect the floor, because the rubber of the product will inevitably leave marks.

Exercise Instructions

1. Did you know that moderate endurance exercise (like 2 times a week for about 30 minutes each time) can greatly improve your health? Your blood pressure, cholesterol, blood sugar, motivation, and even your mood can all improve dramatically with just a little bit of exercise. You can make modest changes to your body shape and, with appropriate nutritional intake , reduce your body fat percentage .

You should always start with a warm-up when exercising. The more strenuous the exercise ahead, the more important it is to warm up. Warming up prepares the body for load, stimulates the cardiovascular system, and protects ligaments, tendons, and joints from injury. It also helps reduce the risk of cramps and muscle damage. Risk of injury.

Product Specifications

Product Name: Magnetic Rowing Machine

Model No.: 5303D

Transmission System: Belt drive

Resistance Type: Magnetic resistance

Resistance Adjustment: 16 levels of micro-adjustment

Weight Capacity: 265LBS

Suitable for users 4'7" to 6'7" tall

Bluetooth APP:



Besyfit,



Kinomap

Expand dimensions (IN): 66*19*25.9

Product Net Weight (LBS): **43 LBS**

Product Gross Weight (LBS): **52 LBS**

①Reminder: The product size, net weight, and gross weight provided are approximate values. For specific size and weight information, please refer to the actual products

JOIN THE APP Besyfit

Scan the QR code to download



Packing List

1. Main frame assembly (1)
2. the front bottom tube assembly (12)
3. Slide rail assembly (2)
4. Seat cushion (57)
5. Right and left seat cushion support plate assembly (4) (3)
6. Adjustable rear foot cover (94) 2PCS
7. Digital watch (14)
8. Pedal shaft (60)
9. Pedal (24)
10. Foot pad (69)
11. AAA battery 2PCS (66)
12. Hardware pack
13. User Manual

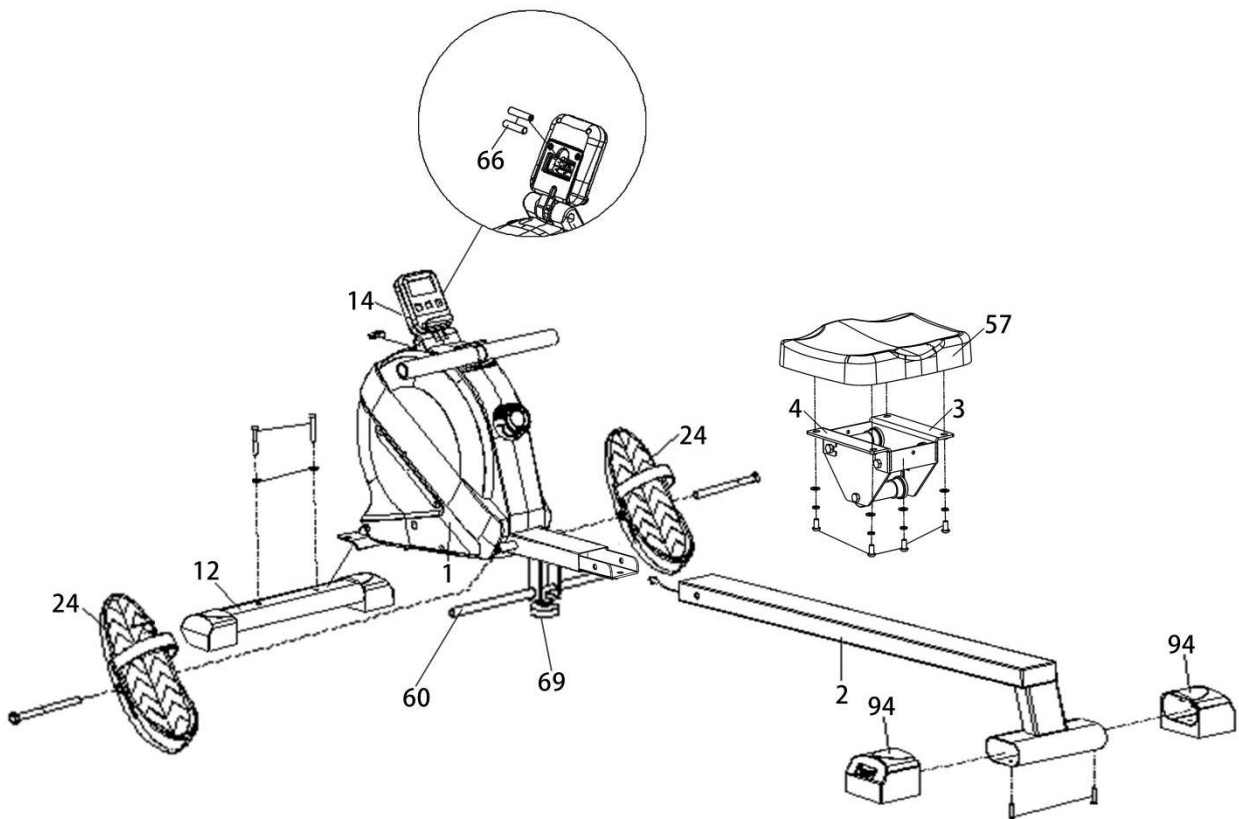

Hardware Pack

STEP 1

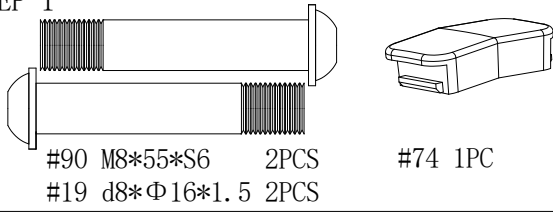

#90 M8*55*S6 2PCS
#19 d8*Φ16*1.5 2PCS

#74 1PC

STEP 2

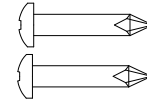

#91 ST4.2*25 2PCS

STEP 3

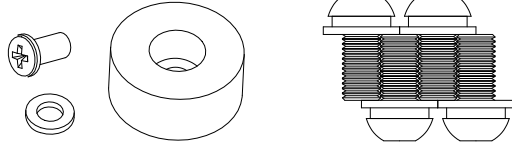

#98 Φ33*Φ8*13 1PC
#68 M6*16*Φ12 1PC
#67 d6*Φ12*1.2 1PC

#6 M8*20*S6 4PCS
#49 d8 4PCS
#19 d8*Φ16*1.5 4PCS

STEP 4

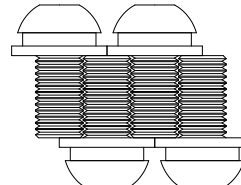

#25 d10*Φ20*2 4PCS
#21 M10*20*S6 4PCS
#22 d10 4PCS

STEP 6

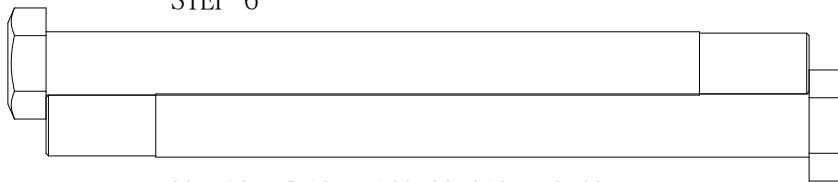

#23 M12 *Φ12.5*160*23*S19 2PCS

B S17*19 1PC

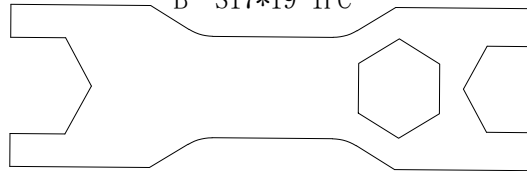

C S13-14-15 1PC

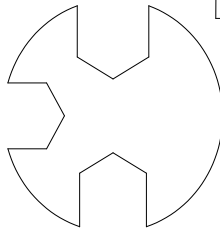

A S6 1PC

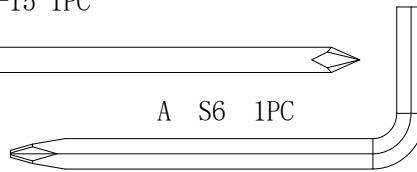

Product Exploded View

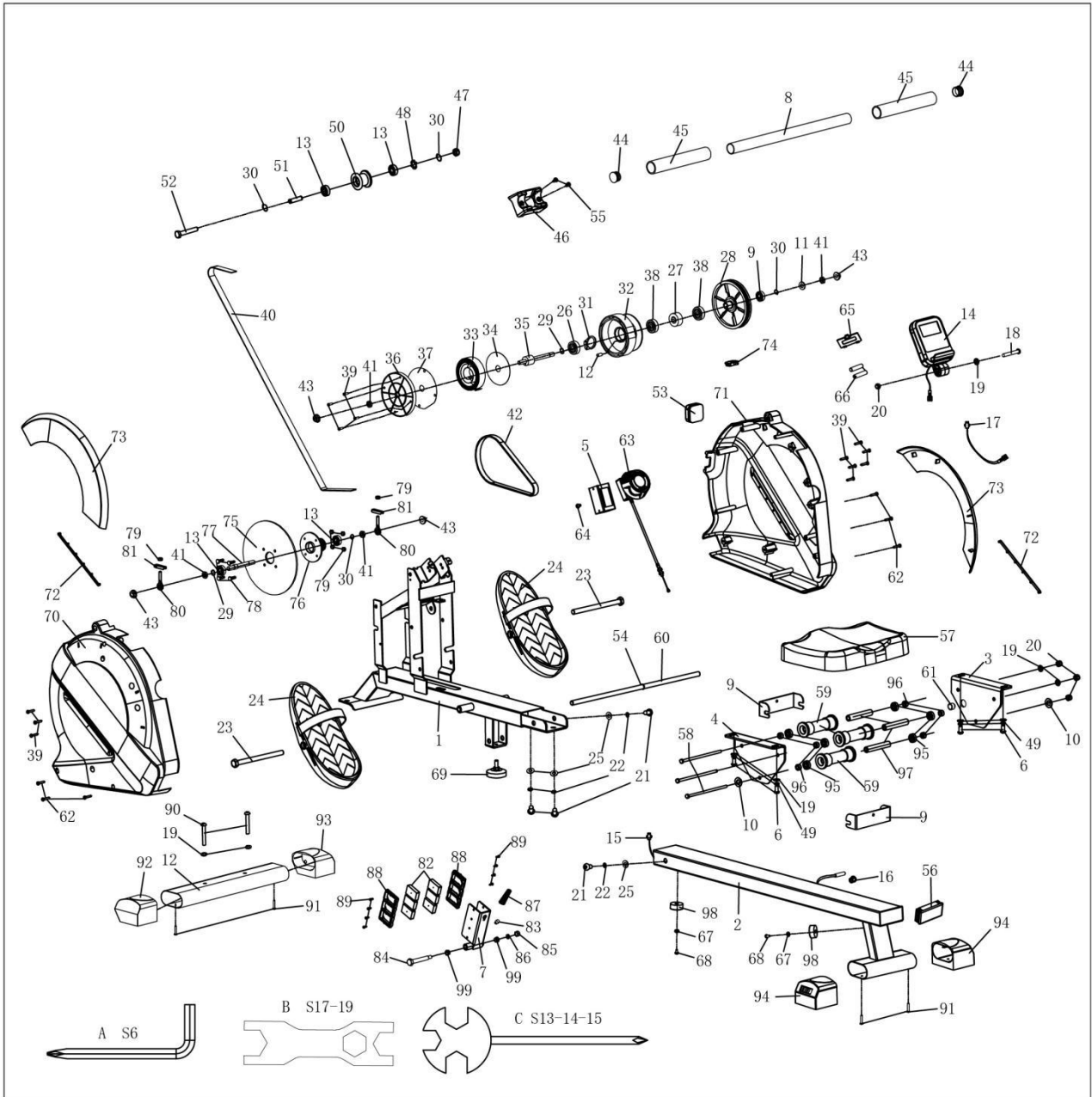

Parts List

Number	Product Specifications	quantity	Number	Product Specifications	quantity
1	Main frame assembly	1	39	Cross recessed pan head self-tapping screws ST4.2*19*Φ8	13
2	Slide rail assembly	1	40	Webbing t1.5*22*2150	1
3	Right seat cushion support plate assembly	1	41	Hexagonal thin nut M10*1*H5*S17	3
4	Left seat cushion support plate	1	42	Belt 6PJ2 37	1
5	Fine adjustment fixed tube	1	43	Hexagonal flange nut M10*1*H8*S15	4
6	Hexagon socket pan head bolt M8*20 *S6	4	44	Round tube plug φ 28*16	2
7	Magnetic plate assembly	1	45	Unbreakable handle	2
8	Handle	1	46	Handle pad	1
9	U-shaped baffle	2	47	Nylon nut M6*H6*S10	1
10	lock washer	2	48	Wave pad D10	1
11	Washer d10*Φ20*1.5	1	49	Spring pad d8	4
12	Webbing fixed shaft Φ 5*43	1	50	Webbing pulley	1
13	Bearing 6000-2RS	3	51	Webbing axle	
14	Digital watch	1	52	Hexagonal bolt M6*55	1
15	Pin sensor	1	53	Front support pad	1
16	Wire hole plug	1	54	Shaft retaining ring d1 2	1
17	Relay line	1	55	Cross recessed pan head screw M5*10	2
18	Hexagon socket pan head bolt M8*45	1	56	Square tube plug J80*40*18	1
19	Washer d8*Φ16*1.5	6	57	Seat cushion	1
20	Nylon nut M8*H7.5*S13	4	58	Hexagonal bolt M8*120*15*S14	2
21	Hexagonal pan head bolt M10*20*S6	4	59	Roller Φ 40*9 6	3
22	Spring pad d10	4	60	Pedal shaft	1
23	Hexagonal bolt M12*Φ12.5*160*23*S19	2	61	Round magnet Φ15 *7	1
24	Pedal	2	62	Cross recessed pan head self-drilling and tapping screws ST4.2*16*Φ8	6
25	Washer d10*Φ20*2	4	63	Fine-tuning knob	1
26	Bearing 6300-2RS	1	64	Cross recessed pan head screw M5*10*Φ10	1
27	One way bearing	1	65	Battery cover	1
28	Belt pulley Φ 130*21.75*6PJ	1	66	Battery	2
29	Wave washer d10*Φ15.5*0.3	3	67	Washer d 6 *Φ 12 * 1.2	2
30	Shaft retaining ring d10	4	68	Cross recessed pan head screw M6*16*Φ12	2
31	Hole retaining ring d35	1	69	Foot pad M8	1

32	Webbing wheel Φ 112*67.5	1
33	Scroll spring t0.5*22*5080	1
34	Webbing pulley PC board Φ 89.5* Φ 16*0.5	1
35	Webbing axle combination Φ 22*130	1
36	Webbing pulley outer cover Φ 118.5*11.8	1
37	Webbing pulley outer cover PC board Φ 111* Φ 16*0.5	1
38	Bearing 16003-2RS	2
77	Aluminum wheel inertia wheel axle	1
78	Hexagonal bolt M6*16*S10	4
79	Nylon nut M6*H6*S10	4
80	Chain adjustment bolt M6*40* Φ 10*2.5	2
81	Chain adjustment U seat	2
82	Square magnet	6
83	Small plug ϕ 10*12	1
84	Hexagonal bolt M10*75	1
85	Nylon nut M 10	1
86	Washer d 10	1
87	Conical compression spring	1
88	Magnet positioning grid	2
89	Cross recessed pan head self-tapping screws ST3*10* Φ 5.6	8
90	Hexagon socket pan head bolt M8*55*20*S6	2
91	Cross recessed pan head self-drilling and tapping screws ST4.2*25	4

70	Left chain cover	1
71	Right chain cover	1
72	Decorative strip	2
73	Chain cover decorative cover	2
74	Cover hole plug	1
75	Aluminum wheel	1
76	Aluminum wheel hub combination	1
92	Foot cover with roller left	1
93	Foot cover with roller right	1
94	Adjustable rear foot cover	2
95	Bearing 608ZZ	6
96	Roller spacer d8* Φ 15*4	6
97	Spacer ϕ 12* ϕ 8.1*77	3
98	Foot pad Φ 33* Φ 8*13	2
99	Bushing	2
A	Hexagonal cross wrench S6	1
B	Dead Wrench S17-19 Inside S17	1
C	Cross wrench S 13-14-15 _	1

Installation Steps

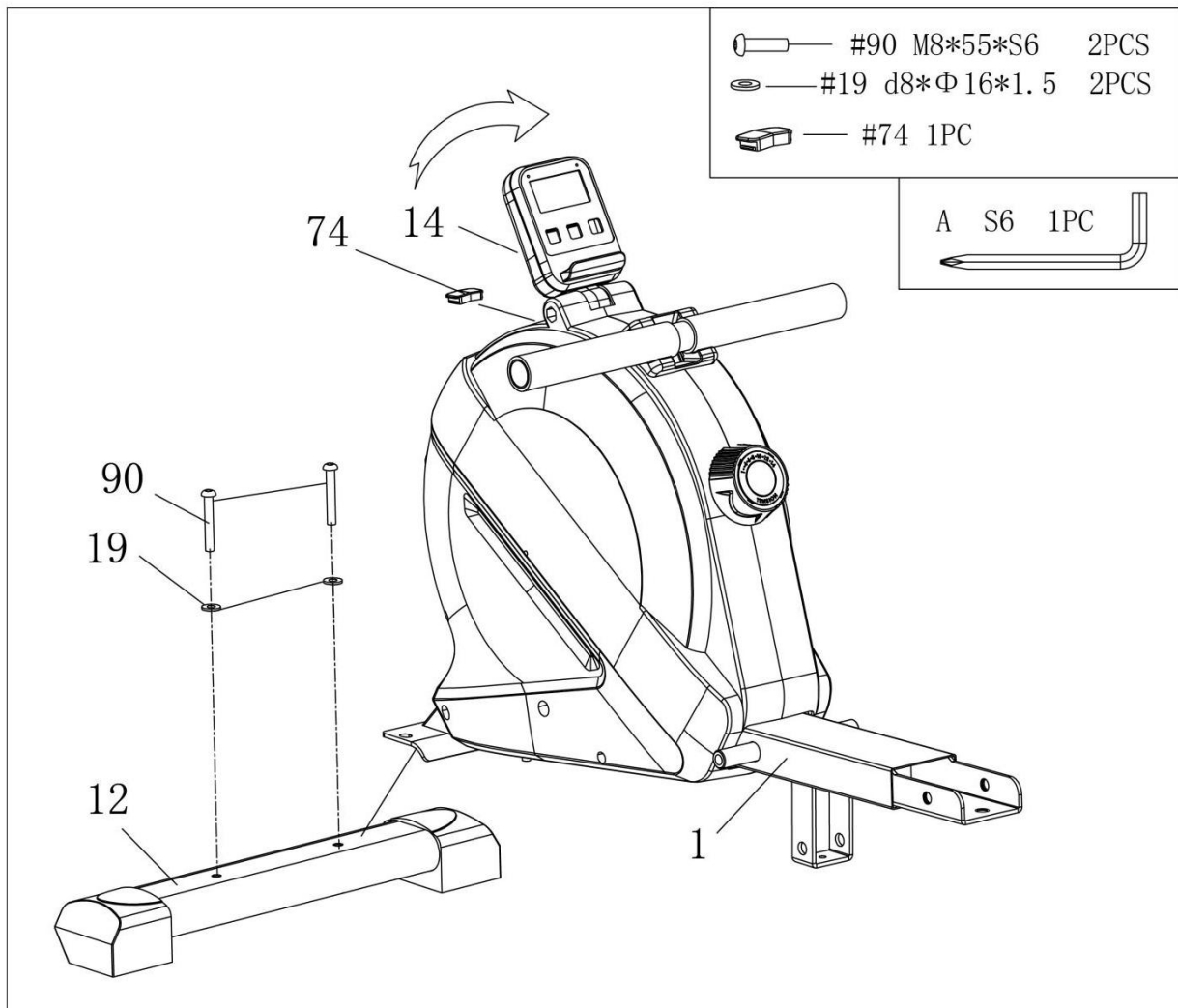

STEP 1:

A. Use hexagon socket pan head bolts (90) and washers (19) to secure the front bottom tube assembly (12) to the front of the main frame assembly (1), and tighten with an hexagon socket wrench (A). Pay attention to the direction of the front bottom tube assembly (12) and place the roller in front.

B. Rotate the digital watch (14) to the appropriate angle.

C. Insert the cover hole plug (74) into the cover hole on the back of the watch.

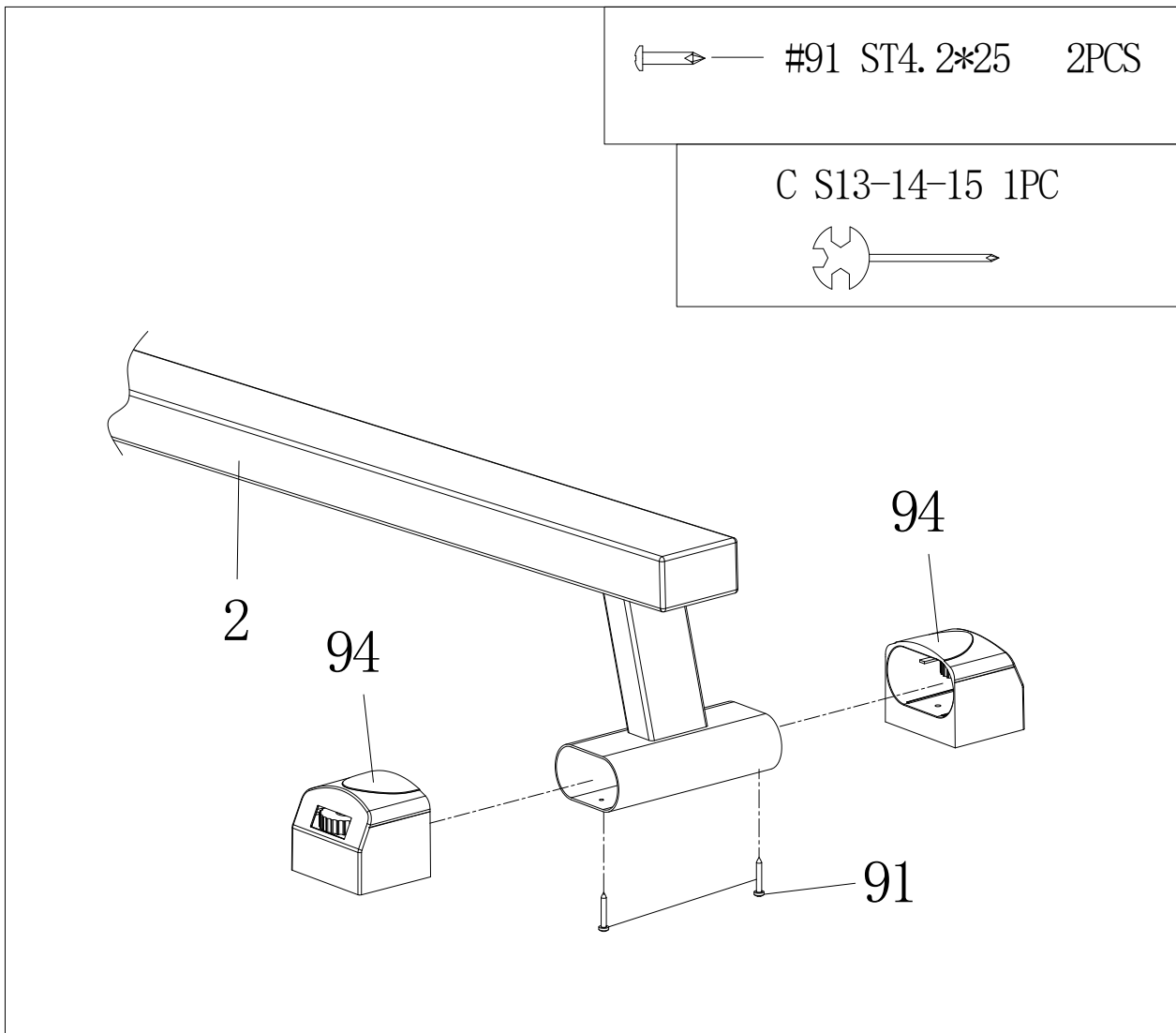

STEP 2 :

A. Use cross-recessed pan-head self-drilling and tapping screws (91) to lock the adjustable rear foot cover (94) on the rear bottom tube of the slide rail (2).

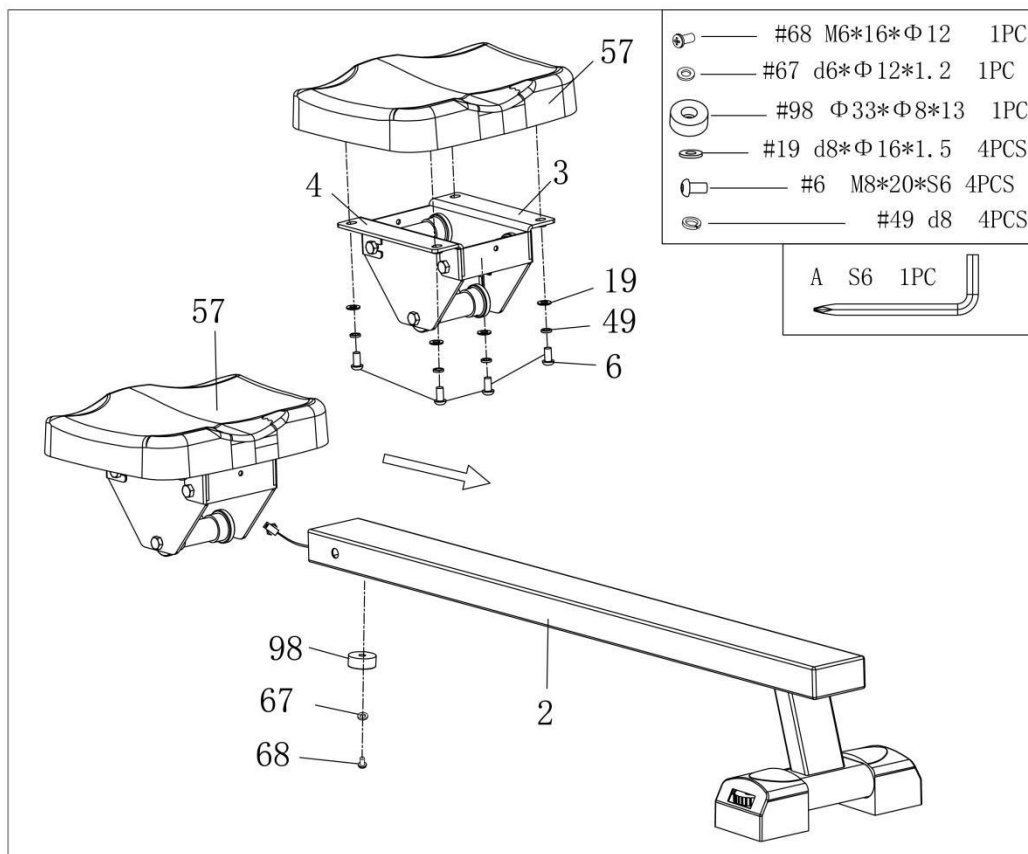

STEP 3 :

A. Use hexagon socket pan head bolt (6), washers (19) and spring pad (49) to fix the seat cushion (57) to left seat cushion support plate (4) and right seat cushion support plate (3) . (Pay attention to the direction of the seat cushion and support plate: when the seat cushion has two gaps in the front, the support plate with induction magnets is on the right side)

B. First put the seat cushion assembly (57) into the slide rail assembly (2), paying attention to the direction of the seat cushion . (Those with magnets on the seat cushion support plate and those with induction lines on the guide rails must be on the right side)

C. Use cross recessed pan head screws (68) and washers (67) to lock the foot pad (98) on the slide rail assembly (2).

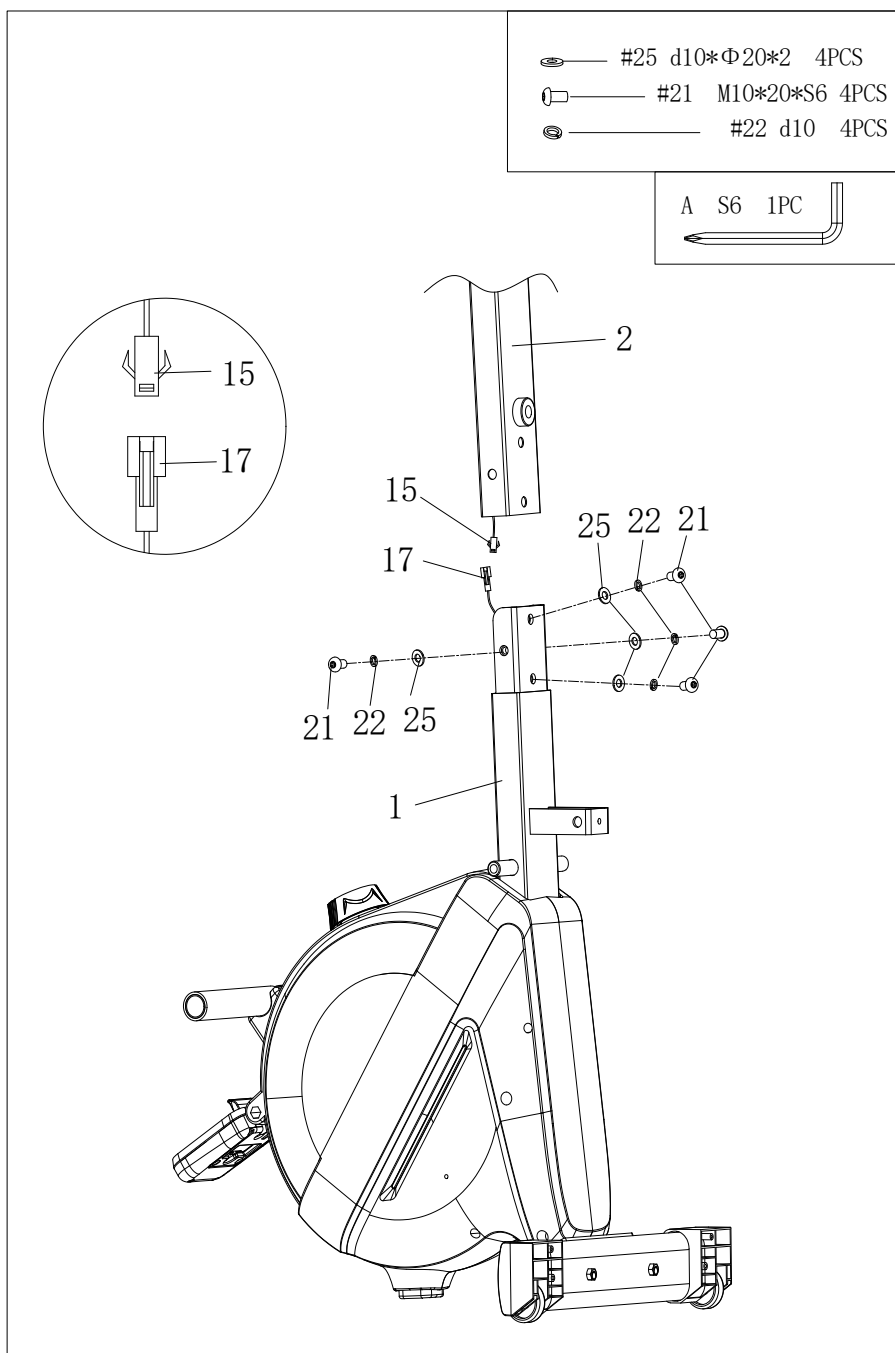

STEP 4 :

A. First stand up the main frame (1) and connect the pin sensor line (15) and the trunk line (17).

B. Then use hexagon socket screws (21), washers (25) and spring pad (22) to fix the slide rail assembly (2) to the main frame assembly (1).

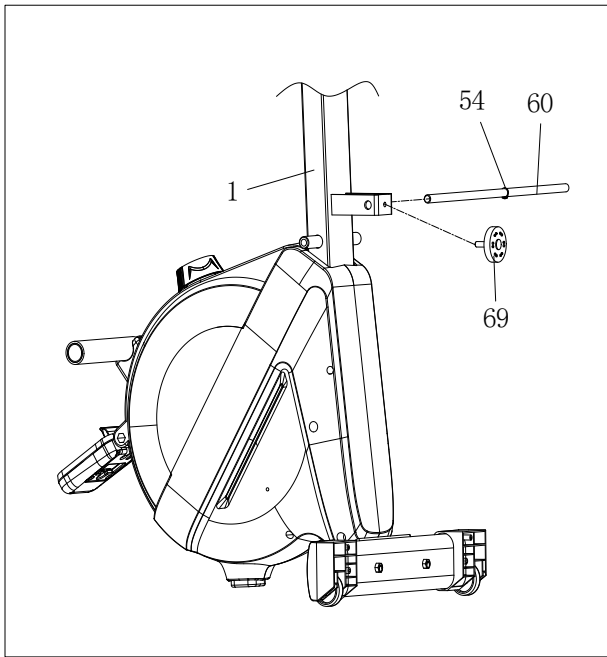

STEP 5:

A. the long end of the pedal shaft (60) into the hole of the main frame (1), and then lock it with the foot pad (69).

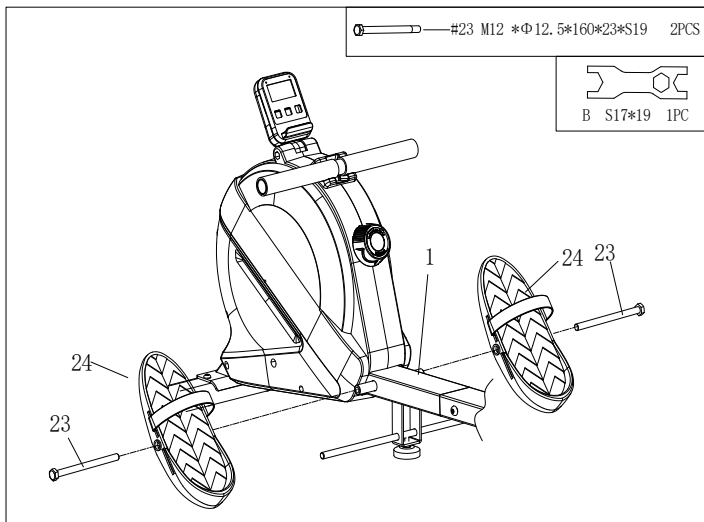

STEP 6 :

A. Use hexagonal bolts (23) to install the foot pedals (24) to both sides of the main frame assembly, and tighten with an open-ended wrench (B).

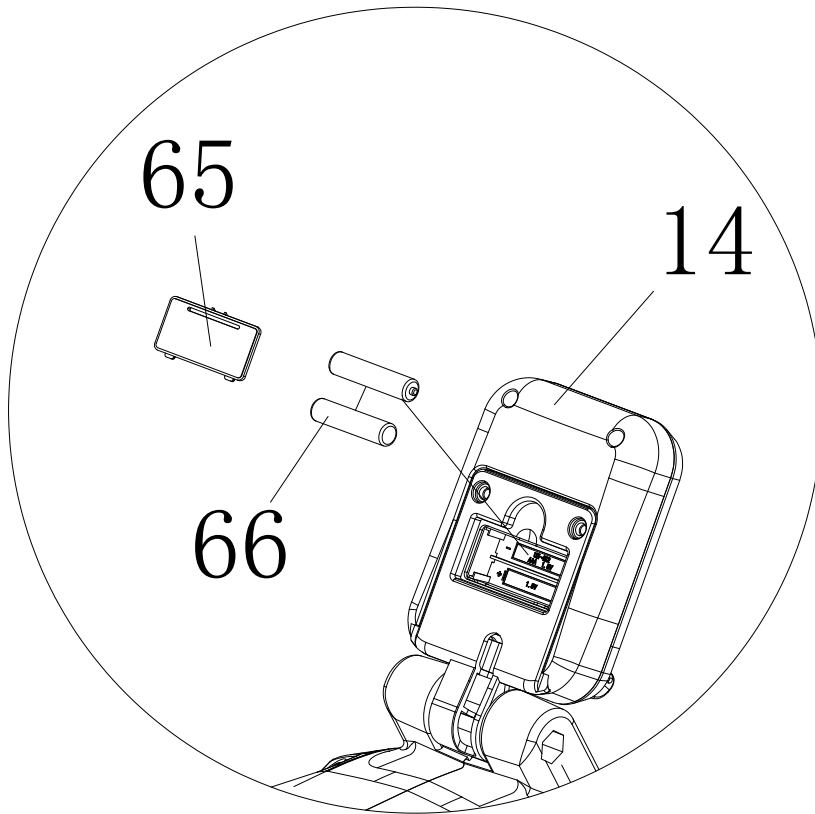

STEP 7 :

A. First, take out the battery cover (65) behind the digital watch (14), and put in 2 batteries (66). Please pay attention to the positive and negative poles of the batteries. After the electronic watch is powered on and has a display, put the battery cover (65) back.

Features

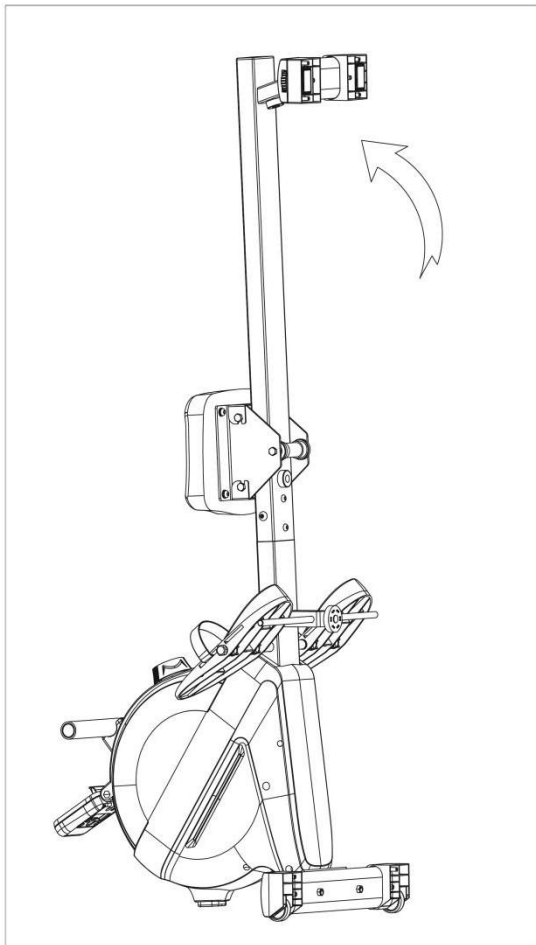

A. When this product is not in use, the whole machine can be flipped up to avoid occupying space. Here's how to do it.

B.1. Move the rowing machine to the wall, then flip it up and stand it upright in the corner.

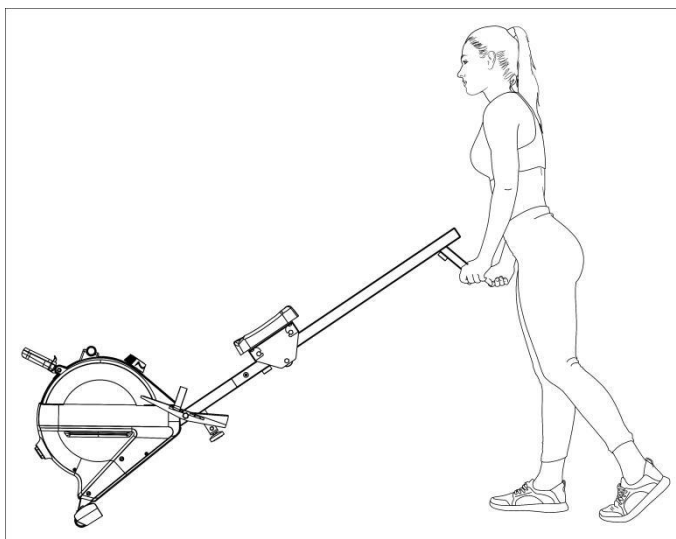

When you need to move the product, you can grab the rear riser with your hands and lift the product up until the rollers on the front bottom tube foot cover are in complete contact with the ground, then you can move the product. When you reach your destination, just put it down gently and keep it steady.

Adjustment Guidelines

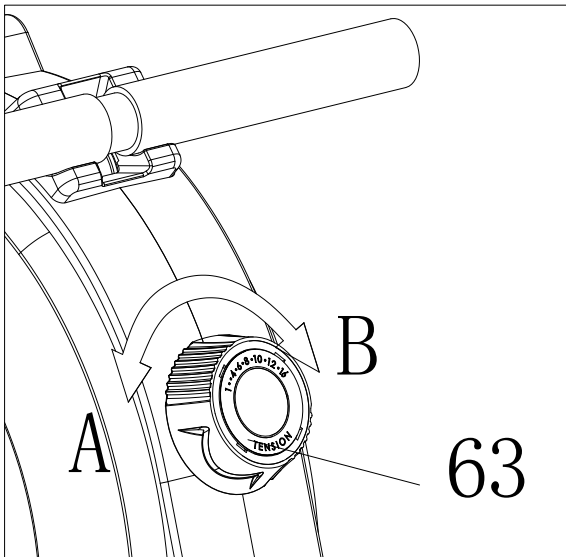

Resistance adjustment method:

A. Rotate the fine-tuning knob (63) clockwise (direction B) to increase resistance. When the triangle points to 16, the resistance is greatest.

B. Rotate the fine-tuning knob (63) counterclockwise (direction A) to reduce resistance. When the triangle points to 1, the resistance is minimal.

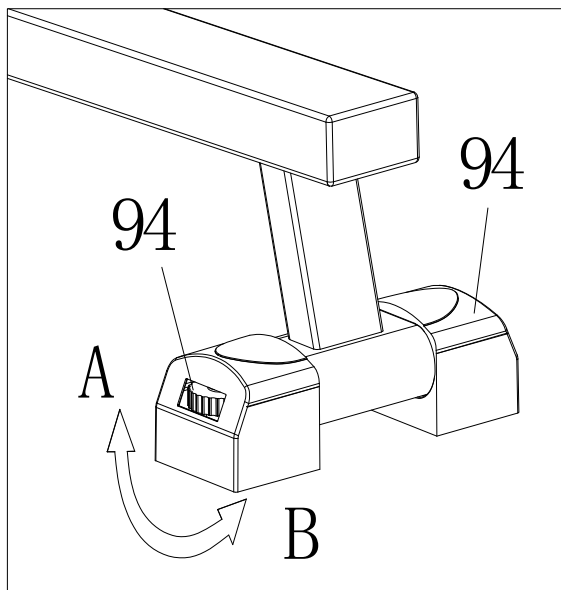

If the whole machine is unbalanced and only has three legs for support, you can adjust the height of the adjustable foot covers (94) to make the whole machine stable. Adjust the height of the foot pads in the direction A or B as shown in the figure.

FCC Warning:

This equipment has been tested and found to comply with the limits for a Class B digital device, pursuant to part 15 of the FCC Rules. These limits are designed to provide reasonable protection against harmful interference in a residential installation. This equipment generates, uses and can radiate radio frequency energy and, if not installed and used in accordance with the instructions, may cause harmful interference to radio communications. However, there is no guarantee that interference will not occur in a particular installation. If this equipment does cause harmful interference to radio or television reception, which can be determined by turning the equipment off and on, the user is encouraged to try to correct the interference by one or more of the following measures:

- Reorient or relocate the receiving antenna.
- Increase the separation between the equipment and receiver.
- Connect the equipment into an outlet on a circuit different from that to which the receiver is connected.
- Consult the dealer or an experienced radio/TV technician for help.

Caution: Any changes or modifications to this device not explicitly approved by manufacturer could void your authority to operate this equipment.

This device complies with part 15 of the FCC Rules. Operation is subject to the following two conditions:

(1) This device may not cause harmful interference, and (2) this device must accept any interference received, including interference that may cause undesired operation.

This equipment complies with FCC radiation exposure limits set forth for an uncontrolled environment. This equipment should be installed and operated with minimum distance 20cm between the radiator and your body.