



FCC TEST REPORT

Test report
On Behalf of
Shenzhen Ouchao Technology Co., Ltd
For
4-in-1 wireless charging
Model No.: DH19, DH11, DH13, DH15, DH16, DH17, DH18, DH12
FCC ID: 2BH8E-DH19

Prepared for : Shenzhen Ouchao Technology Co., Ltd
303, Building 34, Longzhu Garden, Xixiang Street, Bao'an District, Shenzhen,
China

Prepared By : Shenzhen Tongzhou Testing Co.,Ltd
1th Floor, Building 1, Haomai High-tech Park, Huating Road 387, Dalang
Street, Longhua, Shenzhen, China

Date of Test: 2024/7/26 ~ 2024/8/7

Date of Report: 2024/8/8

Report Number: TZ240706196-E1

The test report apply only to the specific sample(s) tested under stated test conditions
It is not permitted to copy extracts of these test result without the written permission of the test
laboratory.



TEST RESULT CERTIFICATION

Applicant's name : Shenzhen Ouchao Technology Co., Ltd
Address : 303, Building 34, Longzhu Garden, Xixiang Street, Bao'an District, Shenzhen, China
Manufacture's Name..... : Shenzhen Ouchao Technology Co., Ltd
Address : 303, Building 34, Longzhu Garden, Xixiang Street, Bao'an District, Shenzhen, China

Product description

Trade Mark : **OCHAO**
Product name..... : 4-in-1 wireless charging
Model..... : DH19, DH11, DH13, DH15, DH16, DH17, DH18, DH12
Standards..... : FCC Rules and Regulations Part 15 Subpart C (Section 15.209), ANSI C63.10: 2013

This publication may be reproduced in whole or in part for non-commercial purposes as long as the Shenzhen Tongzhou Testing Co.,Ltd is acknowledged as copyright owner and source of the material. Shenzhen Tongzhou Testing Co.,Ltd takes no responsibility for and will not assume liability for damages resulting from the reader's interpretation of the reproduced material due to its placement and context.

Date of Test..... :
Date (s) of performance of tests..... : 2024/7/26 ~ 2024/8/7
Date of Issue..... : 2024/8/8
Test Result..... : **Pass**

Testing Engineer : Nancy Li

(Nancy Li)

Technical Manager : Hugo Chen

(Hugo Chen)

Authorized Signatory : Andy Zhang

(Andy Zhang)



	Table of Contents	Page
1	TEST SUMMARY	4
1.1	TEST PROCEDURES AND RESULTS.....	4
1.2	TEST FACILITY	4
1.3	MEASUREMENT UNCERTAINTY	4
2	GENERAL INFORMATION.....	5
2.1	General Description of EUT.....	5
2.2	Operation of EUT during testing.....	5
2.3	Description of Test Setup	6
2.4	Description of Test Facility	6
3	Measurement Instruments List.....	7
4	CONDUCTED EMISSION TEST	8
4.1	Block Diagram of Test Setup.....	8
4.2	Conducted Power Line Emission Limit.....	8
4.3	Test Procedure	8
4.4	Test Result.....	9
5	Bandwidth	11
5.1	Block Diagram of Test Setup.....	11
5.2	Rules and specifications.....	11
5.3	Test Procedure	11
5.4	Test Result.....	12
6	RADIATED EMISSIONS.....	13
6.1	Block Diagram of Test Setup.....	13
6.2	Rules and specifications.....	14
6.3	Test Procedure	15
6.4	Test Result.....	15
7	ANTENNA REQUIREMENT	18
7.	TEST SETUP Photographs of EUT.....	19
8.	Exterior Photographs of the EUT	19
9.	INTERIOR Photographs of the EUT.....	19



1 TEST SUMMARY

1.1 TEST PROCEDURES AND RESULTS

DESCRIPTION OF TEST	FCC RULE	RESULT
CONDUCTED EMISSIONS TEST	PART 15.207	COMPLIANT
RADIATED EMISSION TEST	PART 15.209	COMPLIANT
BANDWIDTH MEASUREMENT	PART 15.215	COMPLIANT
ANTENNA REQUIREMENT	PART 15.203	COMPLIANT

1.2 TEST FACILITY

Test Firm : Shenzhen Tongzhou Testing Co.,Ltd

Address 1th Floor, Building 1, Haomai High-tech Park, Huating Road 387,
Dalang Street, Longhua, Shenzhen, China

1.3 MEASUREMENT UNCERTAINTY

Measurement Uncertainty	
Conducted Emission Expanded Uncertainty	= 2.23dB, k=2
Radiated emission expanded uncertainty(9kHz-30MHz)	= 3.08dB, k=2
Radiated emission expanded uncertainty(30MHz-1000MHz)	= 4.42dB, k=2
Radiated emission expanded uncertainty(Above 1GHz)	= 4.06dB, k=2



2 GENERAL INFORMATION

2.1 General Description of EUT

Equipment	4-in-1 wireless charging
Model Name	DH19, DH11, DH13, DH15, DH16, DH17, DH18, DH12
Model Difference	All the same except for the model name
Test Model	DH19
Trade Mark	
FCC ID	2BH8E-DH19
Antenna Type	Coil Antenna
Antenna Gain	0dBi
Operation frequency	110.5– 205 KHz
Test Frequency	146.3 KHz
Modulation Type	ASK
Power Rating	Input: 5V $\overline{=}$ 3A, 9V $\overline{=}$ 2A Output:15W(MAX), Output Watch:2.5W, Output TWS:5W
Test Sample ID	TZ240706196-1#

2.2 Operation of EUT during testing

Test Modes:		
Mode 1	AC/DC Adapter (9V/2A) + EUT + Wireless charger tester (Load 15W)	Record
Mode 2	AC/DC Adapter (9V/2A) + EUT + Wireless charger tester (Load 5W)	Pre-test
Mode 3	AC/DC Adapter (9V/2A) + EUT + Wireless charger tester (Load 2.5W)	Pre-test
Mode 4	AC/DC Adapter (5V/3A) + EUT + Wireless charger tester (Load 15W)	Pre-test
Mode 5	AC/DC Adapter (5V/3A) + EUT + Wireless charger tester (Load 5W)	Pre-test
Mode 6	AC/DC Adapter (5V/3A) + EUT + Wireless charger tester (Load 2.5W)	Pre-test
Note: All test modes were pre-tested, but we only recorded the worst case in this report.		



2.3 Description of Test Setup

Operation of EUT during testing

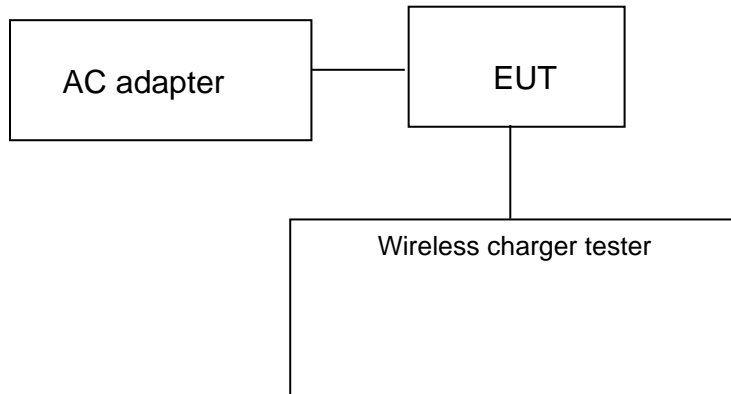

Setup: Transmission mode

- AC adapter information
Model: MDY-10-EH
Input: 100-240VAC, 50/60Hz 0.7A
Output: 5V $\overline{=}$ 3A, 9V $\overline{=}$ 3A, 12V $\overline{=}$ 2.25A, 20V $\overline{=}$ 1.35A
- Wireless charger tester information
Manufacturer: YBZ

2.4 Description of Test Facility

FCC

Designation Number: CN1275

Test Firm Registration Number: 167722

Shenzhen Tongzhou Testing Co.,Ltd has been listed on the US Federal Communications Commission

list of test facilities recognized to perform electromagnetic emissions measurements.

A2LA

Certificate Number: 5463.01

Shenzhen Tongzhou Testing Co.,Ltd has been listed by American Association for Laboratory Accreditation to perform electromagnetic emission measurement.

IC

ISED#: 22033

CAB identifier: CN0099

Shenzhen Tongzhou Testing Co.,Ltd has been listed by Innovation, Science and Economic Development Canada to perform electromagnetic emission measurement.

The 3m-Semi anechoic test site fulfils CISPR 16-1-4 according to ANSI C63.10 and CISPR 16-1-4:2010



3 MEASUREMENT INSTRUMENTS LIST

Item	Test Equipment	Manufacturer	Model No.	Serial No.	Calibration Date	Calibration Due Date
1	Wideband Antenna	schwarzbeck	VULB 9163	958	2022/11/13	2025/11/12
2	EMI Test Receiver	R&S	ESCI	100849/003	2024/1/4	2025/1/3
3	Controller	MF	MF7802	N/A	N/A	N/A
4	RF Cable(below 1GHz)	HUBER+SUHNER	RG214	N/A	2024/1/4	2025/1/3
5	RF Cable(above 1GHz)	HUBER+SUHNER	RG214	N/A	2024/1/4	2025/1/3
6	RE test software	Tonscend	JS32-RE	V5.0.0.0	N/A	N/A
7	Loop Antenna	schwarzbeck	FMZB 1519 B	00023	2022/11/13	2025/11/12
8	Artificial Mains	ROHDE & SCHWARZ	ENV 216	101333-IP	2024/1/4	2025/1/3
9	EMI Test Software	ROHDE & SCHWARZ	ESK1	V1.71	N/A	N/A
10	MXA Signal Analyzer	Keysight	N9020A	MY52091623	2024/1/4	2025/1/3

4 CONDUCTED EMISSION TEST

4.1 Block Diagram of Test Setup

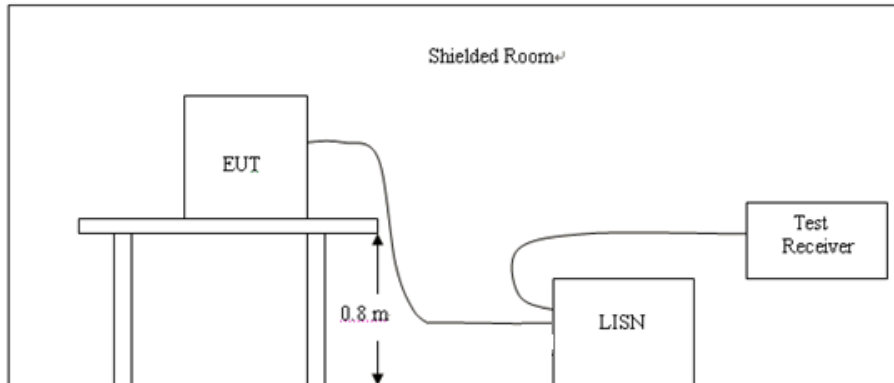

4.2 Conducted Power Line Emission Limit

According to FCC Part 15.207(a)

Frequency (MHz)	Maximum RF Line Voltage (dB μ V)			
	CLASS A		CLASS B	
	Q.P.	Ave.	Q.P.	Ave.
0.15 - 0.50	79	66	66-56*	56-46*
0.50 - 5.00	73	60	56	46
5.00 - 30.0	73	60	60	50

* Decreasing linearly with the logarithm of the frequency

For intentional device, according to §15.207 Line Conducted Emission Limit is same as above table.

4.3 Test Procedure

- 1, The equipment was set up as per the test configuration to simulate typical actual usage per the user's manual. The EUT is a tabletop system, a wooden table with a height of 0.8 meters is used and is placed on the ground plane as per ANSI C63.10.
- 2, Support equipment, if needed, was placed as per ANSI C63.10.
- 3, All I/O cables were positioned to simulate typical actual usage as per ANSI C63.10.
- 4, If a EUT received DC power from the USB Port of Notebook PC, the PC's adapter received AC120V/60Hz power through a Line Impedance Stabilization Network (LISN) which supplied power source and was grounded to the ground plane.
- 5, All support equipments received AC power from a second LISN, if any.
- 6, The EUT test program was started. Emissions were measured on each current carrying line of the EUT using a spectrum Analyzer / Receiver connected to the LISN powering the EUT. The LISN has two monitoring points: Line 1 (Hot Side) and Line 2 (Neutral Side). Two scans were taken: one with Line 1 connected to Analyzer / Receiver and Line 2 connected to a 50 ohm load; the second scan had Line 1 connected to a 50 ohm load and Line 2 connected to the Analyzer / Receiver.
- 7, Analyzer / Receiver scanned from 150 KHz to 30MHz for emissions in each of the test modes



4.4 Test Result

PASS

Temperature	22.8°C	Humidity	55%
Test Engineer	Tony Luo	Configurations	Mode 1

Please refer to following diagram for individual

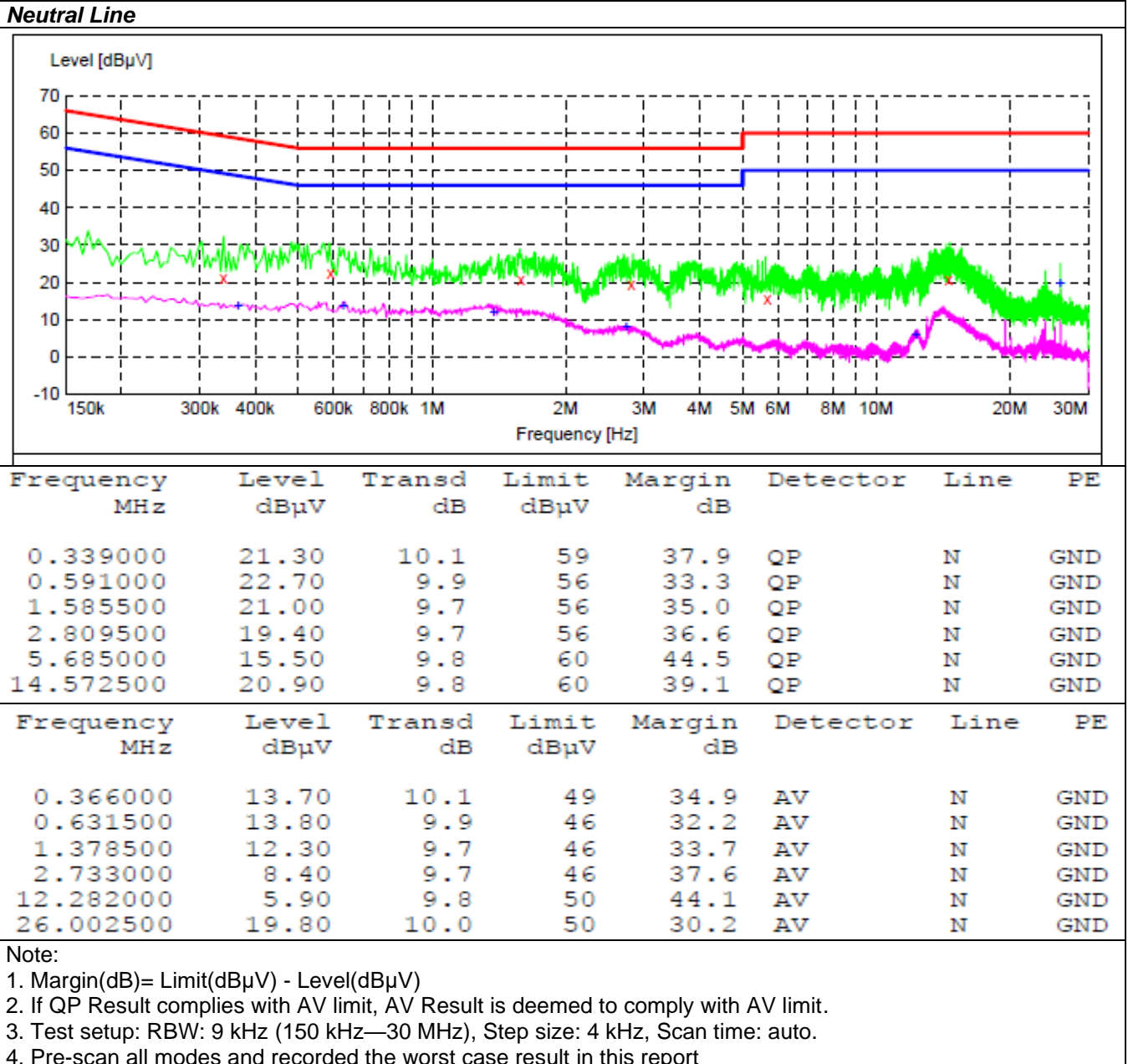

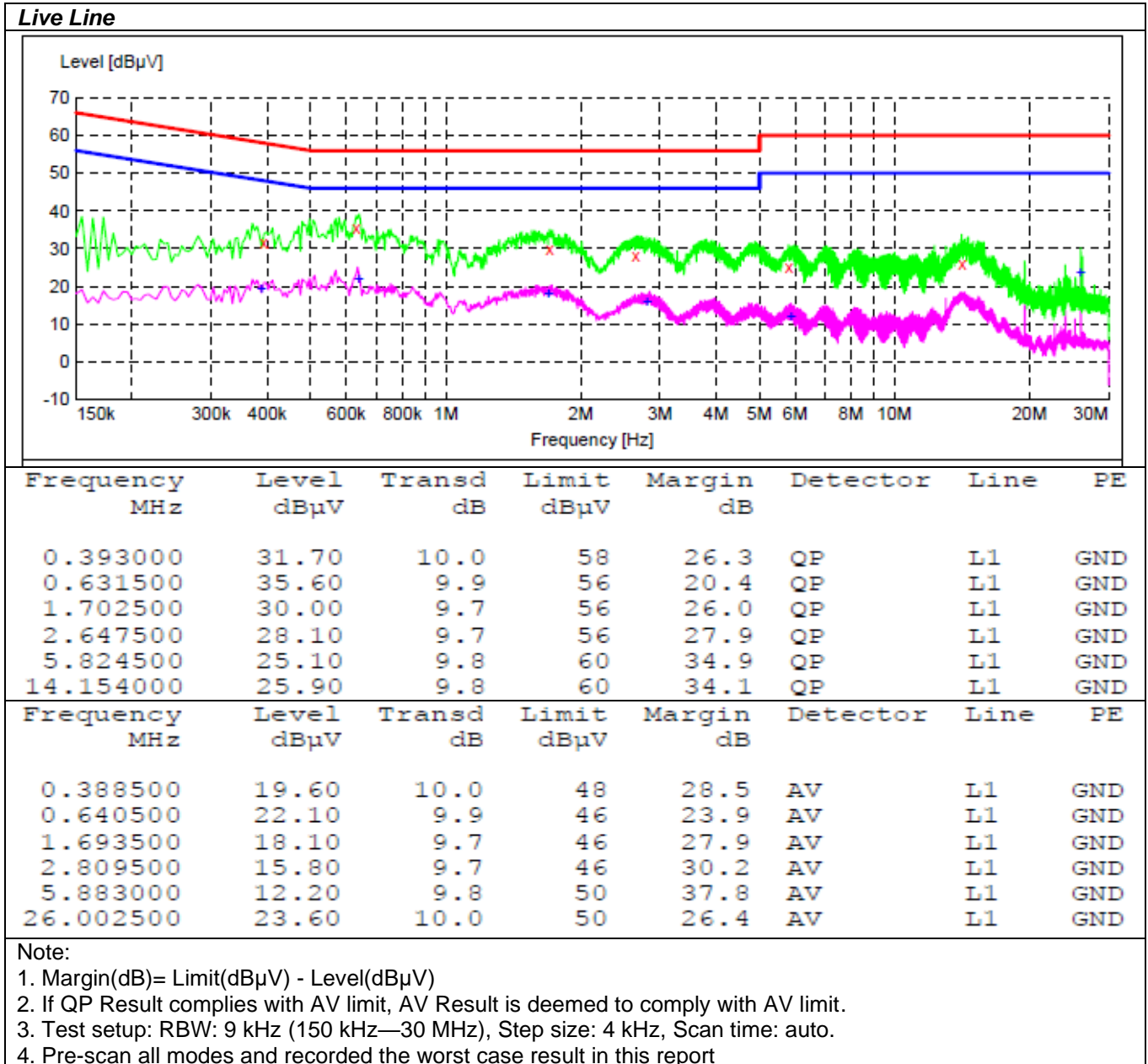

5 BANDWIDTH

5.1 Block Diagram of Test Setup

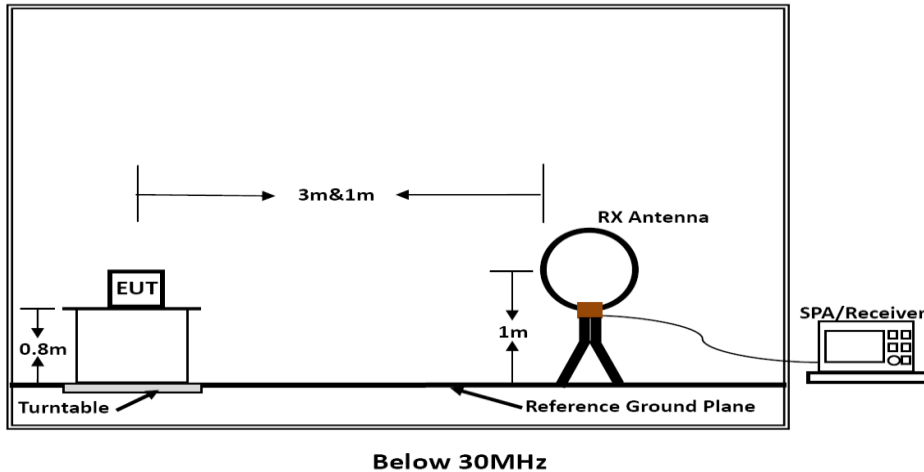

5.2 Rules and specifications

CFR 47 Part 15.215(c)

ANSI C63.10-2013

5.3 Test Procedure

Intentional radiators operating under the alternative provisions to the general emission limits, as contained in §§15.217 through 15.257 and in subpart E of this part, must be designed to ensure that 20dB bandwidth of the emission, or whatever bandwidth may otherwise be specified in the specific rule section under which the equip compliance with the 20dB attenuation specification may base on measurement at the intentional radiator's antenna output terminal unless the intentional radiator uses a permanently attached antenna, in which case compliance shall be deomonstrated by measuring the radiated emissions.



5.4 Test Result

PASS

Temperature	22.8°C	Humidity	55%
Test Engineer	Tony Luo	Configurations	Mode 1

Mode	Freq (KHz)	20dB Bandwidth (Hz)	Limit (kHz)	Conclusion
Tx Mode	146.3	795	/	PASS

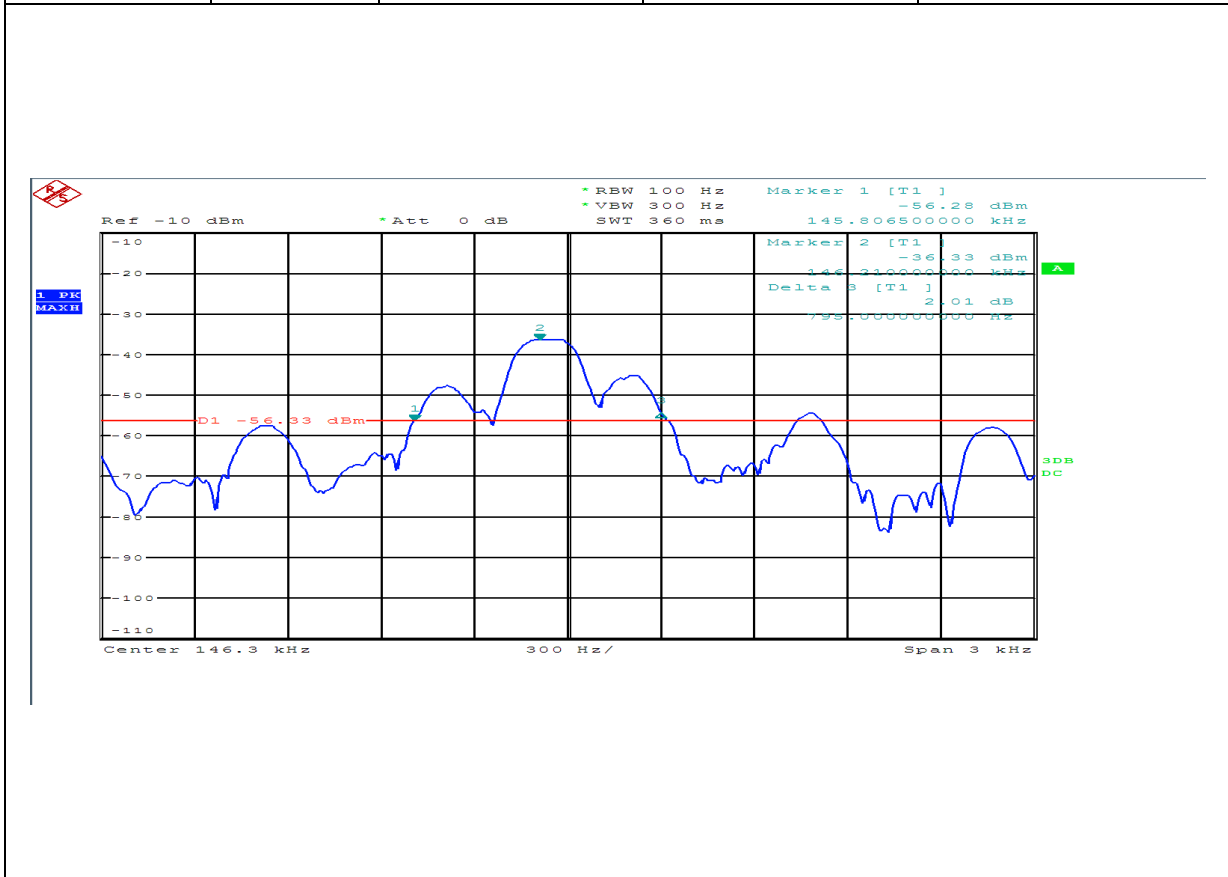

6 RADIATED EMISSIONS

6.1 Block Diagram of Test Setup

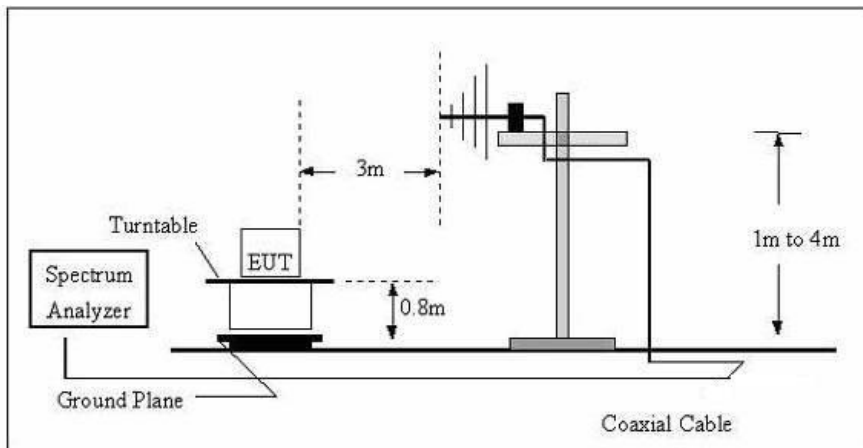
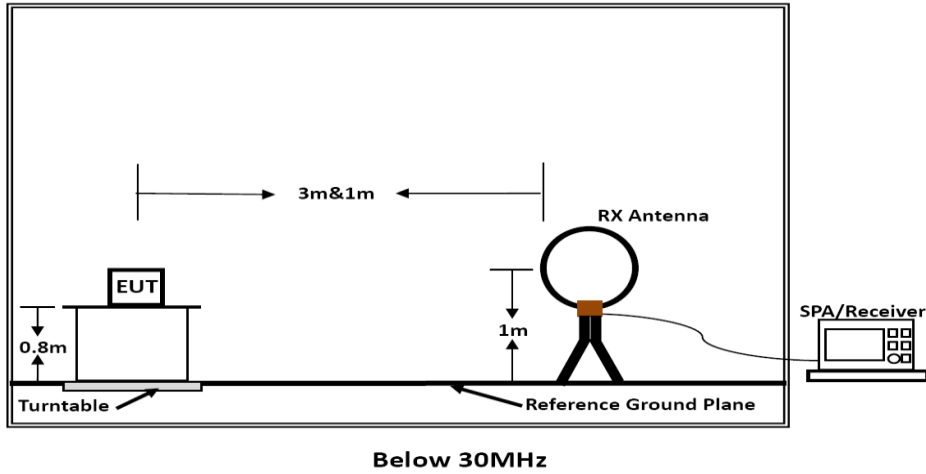



6.2 Rules and specifications

CFR 47 Part 15, section 15.205

Only spurious emissions are permitted in any of the frequency bands listed the tables in these sections.

MHz	MHz	MHz	GHz
0.090-0.110	16.42-16.423	399.9-410	4.5-5.15
1\ 0.495-0.505	16.69475-16.69525	608-614	5.35-5.46
2.1735-2.1905	16.80425-16.80475	960-1240	7.25-7.75
4.125-4.128	25.5-25.67	1300-1427	8.025-8.5
4.17725-4.17775	37.5-38.25	1435-1626.5	9.0-9.2
4.20725-4.20775	73-74.6	1645.5-1646.5	9.3-9.5
6.215-6.218	74.8-75.2	1660-1710	10.6-12.7
6.26775-6.26825	108-121.94	1718.8-1722.2	13.25-13.4
6.31175-6.31225	123-138	2200-2300	14.47-14.5
8.291-8.294	149.9-150.05	2310-2390	15.35-16.2
8.362-8.366	156.52475-156.52525	2483.5-2500	17.7-21.4
8.37625-8.38675	156.7-156.9	2690-2900	22.01-23.12
8.41425-8.41475	162.0125-167.17	3260-3267	23.6-24.0
12.29-12.293	167.72-173.2	3332-3339	31.2-31.8
12.51975-12.52025	240-285	3345.8-3358	36.43-36.5
12.57675-12.57725	322-335.4	3600-4400	(2)
13.36-13.41			

CFR 47 Part 15, section 15.209

The emissions from an intentional radiator shall not exceed the limits in the tables in these sections using an average detector

Frequency (MHz)	Field strength (microvolts/meter)	Measurement distance (meters)
0.009–0.490	2400/F (kHz)	300
0.490–1.705	24000/F (kHz)	30
1.705–30.0	30	30
30–88	100**	3
88–216	150**	3
216–960	200**	3
Above 960	500	3

Limit calculation and transfer to 3m distance as showed in the following table:

Frequency (MHz)	Limit (dBuV/m)	Distance (m)
0.009-0.490	$20\log(2400/F(KHz))+40\log(300/3)$	3
0.490-1.705	$20\log(24000/F(KHz))+40\log(30/3)$	3
1.705-30.0	69.5	3
30-88	40.0	3
88-216	43.5	3
216-960	46.0	3
Above 960	54.0	3

CFR 47 Part 15, section 15.35

When average radiated emission measurements are specified, the limit on the peak level of the radio Frequency emission is 20dB above the maximum permitted average emission limit.

Transmitter Spurious Emissions 9KHz-30MHz			
	9-150KHz	150-490KHz	490KHz-30MHz
Resolution Bandwidth	200Hz	9KHz	9KHz
Video Bandwidth	2KHz	100KHz	100KHz
Detector	Peak	Peak	Peak
Trace Mode	Max Hold	Max Hold	Max Hold
Sweep Time	Auto	Auto	Auto



6.3 Test Procedure

Measurement distance 3m

For the measurement range up to 30MHz in the following plots the field strength result from 3m Distance measurement are extrapolated to 300m and 30m distance respectively, by 40dB/decade, According to part 15.31(f)(2), per antenna factor scaling.

Measurements below 1000MHz are performed with a peak detector and compared to average limits, Measurements with an average detector are not required.

Note:

For battery operated equipment, the equipment tests shall be performed using a new battery.

6.4 Test Result

PASS

Temperature	22.8°C	Humidity	55%
Test Engineer	Tony Luo	Configurations	Mode 1

For 9KHz-30MHz

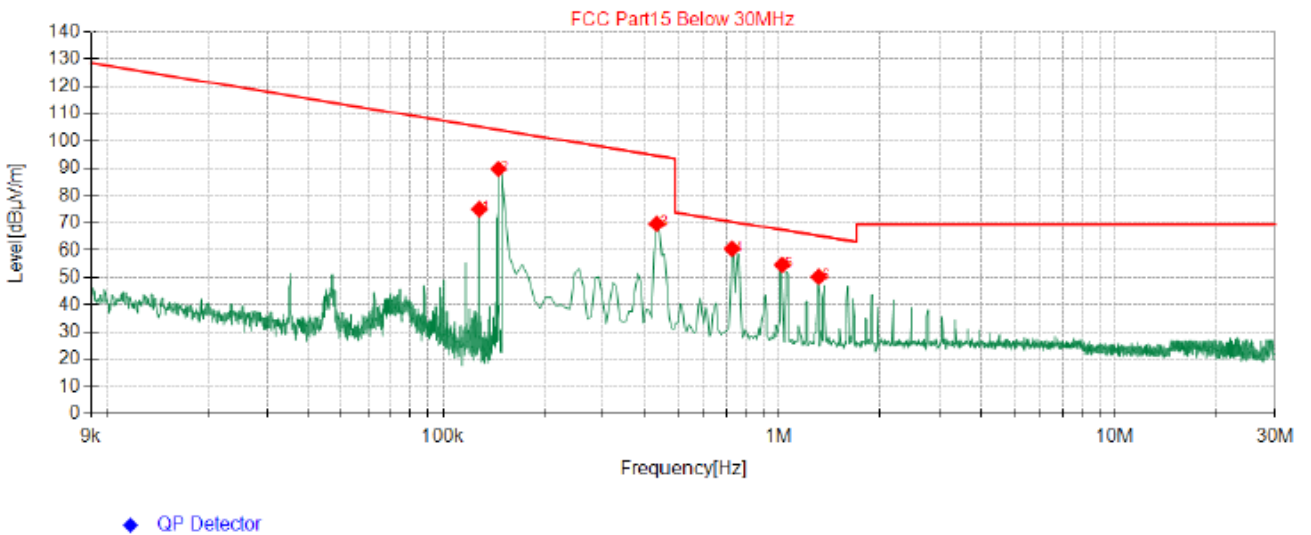

Suspected Data List							
NO.	Freq. [MHz]	Factor [dB/m]	Level [dBµV/m]	Limit [dBµV/m]	Margin [dB]	Height [cm]	Angle [°]
1	0.1283	19.77	74.98	105.24	30.26	100	240
2	0.1463	19.86	89.70	104.09	14.39	100	16
3	0.4336	20.22	69.60	94.57	24.97	100	359
4	0.7246	20.30	60.56	70.41	9.85	100	359
5	1.0231	20.30	54.57	67.42	12.85	100	2
6	1.3142	20.33	50.26	65.26	15.00	100	359

Note:

1 · $Level [dBµA/m] = Reading [dBµV] + Factor [dB/m]$

2 · $Margin [dB] = Limit [dBµV/m] - Level [dBµV/m]$

3 · Measured at antenna position coaxial and coplanar, only record the Coaxial.



For 30MHz-1GHz

Vertical:

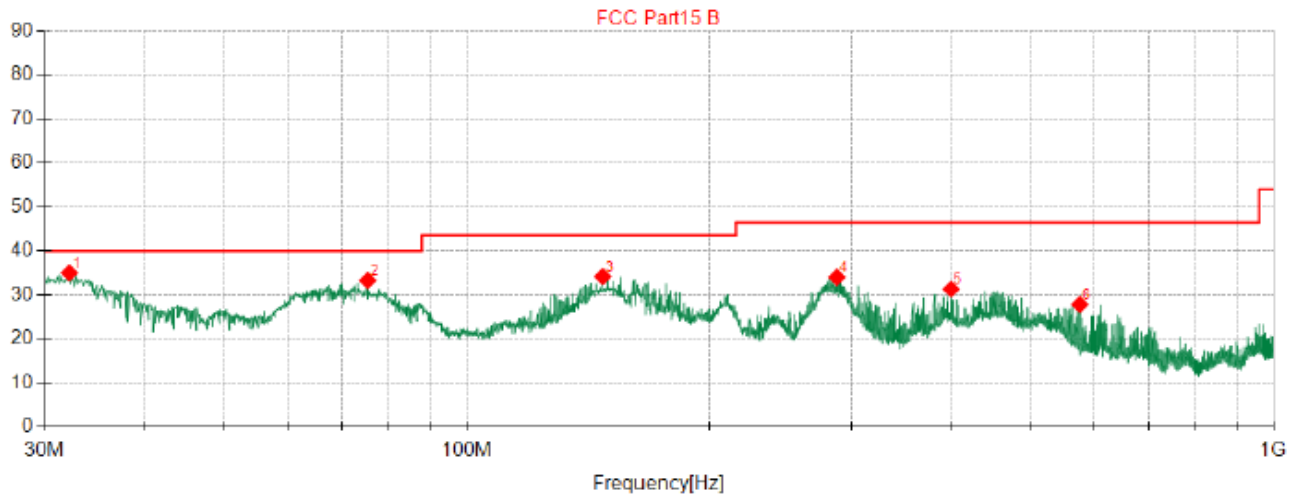

◆ QP Detector

Suspected Data List									
NO.	Freq. [MHz]	Reading [dBμV]	Factor [dB/m]	Level [dBμV/m]	Limit [dBμV/m]	Margin [dB]	Height [cm]	Angle [°]	Polarity
1	32.18	51.16	-16.16	35.00	40.00	5.00	100	28	Vertical
2	75.46	52.54	-19.23	33.31	40.00	6.69	100	136	Vertical
3	147.6	53.36	-19.18	34.18	43.50	9.32	100	302	Vertical
4	287.8	47.09	-13.06	34.03	46.50	12.47	100	210	Vertical
5	398.8	41.41	-10.07	31.34	46.50	15.16	100	274	Vertical
6	575.9	34.01	-6.19	27.82	46.50	18.68	100	203	Vertical

Note:

- 1). Pre-scan all modes and recorded the worst case results in this report(#WostCaseSRD)
- 2). Margin=Limit-Result Level



Horizontal:

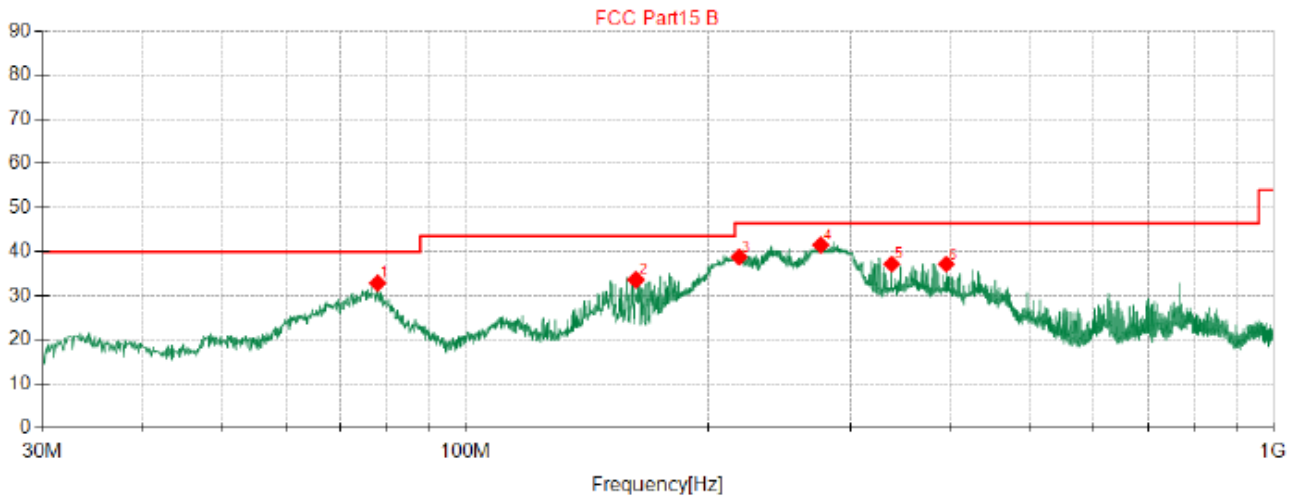

Suspected Data List									
NO.	Freq. [MHz]	Reading [dBμV]	Factor [dB/m]	Level [dBμV/m]	Limit [dBμV/m]	Margin [dB]	Height [cm]	Angle [°]	Polarity
1	78.01	52.61	-19.71	32.90	40.00	7.10	100	356	Horizontal
2	162.7	52.16	-18.51	33.65	43.50	4.85	100	275	Horizontal
3	218.5	53.69	-14.86	38.83	46.50	6.17	100	99	Horizontal
4	275.6	54.81	-13.32	41.49	46.50	5.01	100	282	Horizontal
5	337.2	48.98	-11.78	37.20	46.50	4.30	100	269	Horizontal
6	394.2	47.39	-10.20	37.19	46.50	5.31	100	157	Horizontal

Note:

- 1). Pre-scan all modes and recorded the worst case results in this report(#WostCaseSRD)
- 2). Margin=Limit-Result Level



7 ANTENNA REQUIREMENT

Standard Applicable

For intentional device, according to FCC 47 CFR Section 15.203, an intentional radiator shall be designed to ensure that no antenna other than that furnished by the responsible party shall be used with the device.

Refer to statement below for compliance.

The manufacturer may design the unit so that the user can replace a broken antenna, but the use of a standard antenna jack or electrical connector is prohibited. Further, this requirement does not apply to intentional radiators that must be professionally installed.

Antenna Connected Construction

The antenna used in this product is a Coil Antenna, The directional gains of antenna used for transmitting is 0dBi.

ANTENNA

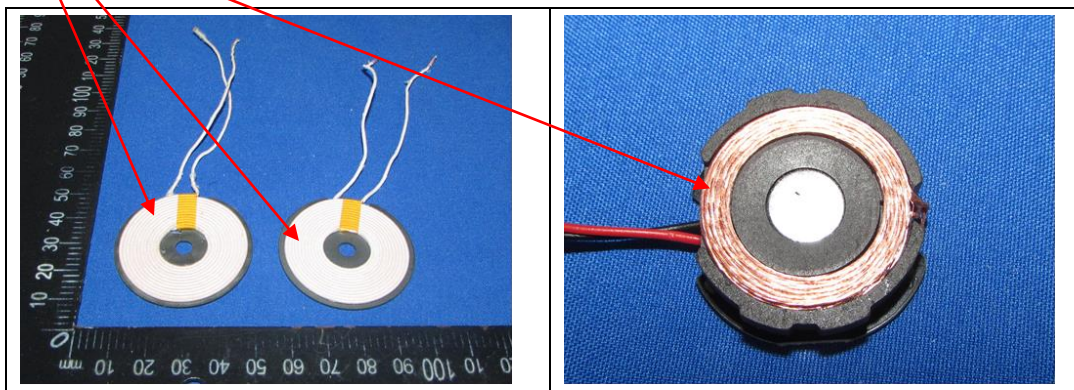



TEST SETUP PHOTOGRAPHS OF EUT

Please refer to separated files for Test Setup Photos of the EUT.

8 EXTERIOR PHOTOGRAPHS OF THE EUT

Please refer to separated files for External Photos of the EUT.

9 INTERIOR PHOTOGRAPHS OF THE EUT

Please refer to separated files for Internal Photos of the EUT.

-----THE END OF REPORT-----