

# 承认书

## SPECIFICATION FOR APPROVAL

客户名称 (CUSTOMER):

客户料号 (CUSTOMER P/N): K1000

品名 (DESCRIPTION):

DATE: 2023-12-21

规格 (SPECIFICATION): G40开单槽+背胶引线长20mm REV.NO.: A0

### 轩宏达电子科技承认签核、盖章

部门	确认/日期	审核/日期	批准/日期	(盖公司公章)
品质	董晚红 2023/12/21	吕惠 2023/12/21	韦函满 2023/12/21	
工程	何伟华 2023/12/21	韦立红 2023/12/21	韦立红 2023/12/21	

备注:

### 承认签核、盖章

部门	确认/日期	审核/日期	批准/日期	(盖公司公章)
开发工程师				
采购				
品质				

备注:

深圳轩宏达电子科技有限公司

# SPECIFICATION FOR APPROVAL

## 1. MECHANICAL DIMENSION (UNIT:mm)

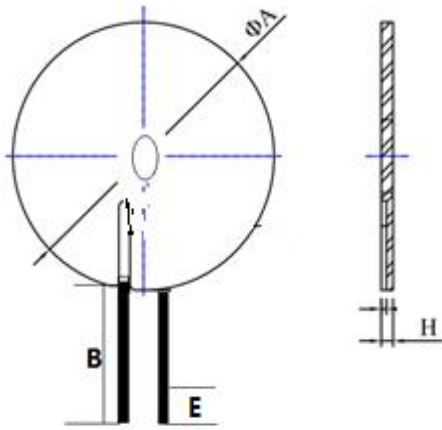

A	B	E	H	
40±1.0	10±3	3±1.5	1.8MAX	

## 2. SCHEMATICS:

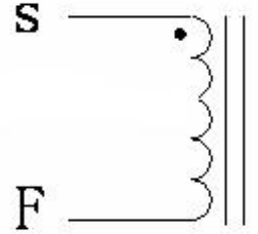

1. 线圈贴磁片，磁片尺寸  
40±1mm, ,  
开单槽。
2. 线圈出线位置  
缠胶纸 1-2Ts;
3. 隔磁片底部要贴3M背胶

## 3. WINDING:

STEP	START-FINISH	WIRE TYPE	TURNS	TAPE	REMARK
N1	S-F	热风线0.08*24*2Pmm 2UEW	10TS (Ref)		

## 4. ELECTRICAL SPECIFICATION:

ITEM	L	DCR	L	Q值	HI-POT
TEST	线圈加磁片	S-F			
CON	100KHz, 0.25V	AT 25°C			
SPEC	6.5uH±10%	95mΩ Max			

## 5. BILF OF MATERIAL:

NO.	ITEM	MATERIAL SPECIFICATION	MANUFACTURER	SGS NO.
1	热风线	热风线0.08*24股	NANJINGJINNINGCO,LTD	
2	无铅锡条	无铅锡条	QIAODO	
3	磁片	G40*0.55锰锌硬磁片开单槽	TAIYI CO.,LTD	
4	胶水	黄胶9999	LIANCHENG CO.,LTD	
5	高温胶纸	8mm宽高温胶纸	CUDAK CO.,LTD	
6	背胶	39.5*0.1 3M胶	CUDAK CO.,LTD	

深圳轩宏达电子科技有限公司		PART NO	
		TITLE	G40开单槽+背胶引线长10mm
DRAWN BY	CHECKED BY		APPROVED BY
何伟华	韦立红		韦立红

# SPECIFICATION FOR APPROVAL

6. SAMPLE TEST DATA									
6.1 DIMENSION TEST (UNIT: mm)									
TEST ITEM	A	B	E	H					
SPEC	40±1.0	25±3	3±1.5	1.8MAX					
1	49.8	25.6	3.50	1.50					
2	49.9	25.4	3.60	1.20					
3	49.5	24.9	3.70	1.30					
4	50	25.8	3.80	1.28					
5	49.86	24.98	4.00	1.46					
6									
7									
8									
9									
10									
MAX	50.00	25.80	4.00	1.50					
MIN	49.50	24.90	3.50	1.20					
AVERAGE	49.81	25.34	3.72	1.35					
6.2 ELECTRICAL TEST									
TEST ITEM	L		DCR	IDC		Q	HI-POT		
	S-F		S-F						
TEST COND	100KHz/0.25v		AT 25°C						
SPEC	6.5uH ±10%		95mΩ (Max)						
1	6.51		70.00						
2	6.52		72.00						
3	6.49		70.10						
4	6.53		70.05						
5	6.52		70.16						
6									
7									
8									
9									
10									
MAX	6.53		72.00						
MIN	6.49		70.00						
AVERAGE	6.51		70.46						
深圳轩宏达电子科技有限公司					PART NO		G40开单槽+背胶引线长 25mm		
					TITLE				
DRAWN BY			CHECKED BY			APPROVED BY			
何伟华			韦立红			韦立红			