

APPROVAL SHEET

CrossAir™ SMD Antenna series
RoHS Compliance

PN: CA-C03

2.4 GHz ISM band antenna

Approval sheet

FEATURES

1. Surface Mounted Devices (SMD) with a small dimension of 5.5 X 2.0 X 1.0 mm³ meet miniaturization trend.
2. Low power loss and high antenna efficiency.
3. High stability in Temperature and Humidity Change.

APPLICATIONS

1. 2.4GHz ISM band RF applications
2. Bluetooth, ZigBee, Wireless, HomeRF
3. WIFI (2.4G only)

CONSTRUCTION

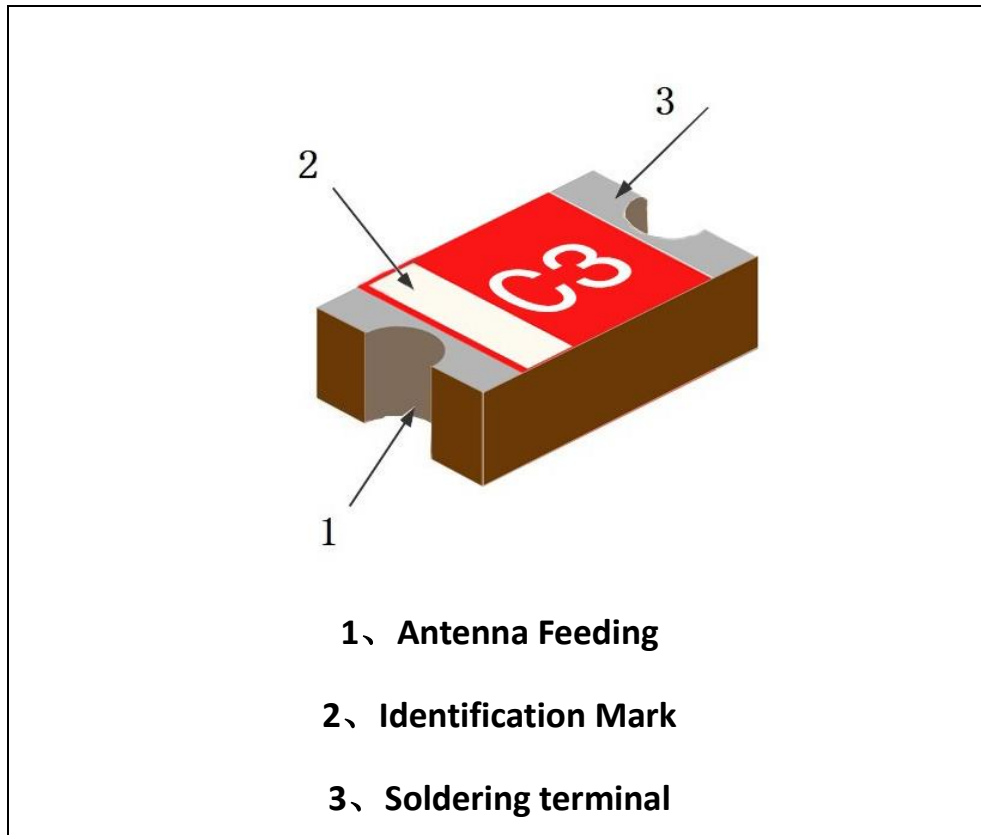

DIMENSIONS

Figure	Symbol	Dimension(mm)
<p>W= 2. 0 (mm)</p> <p>a=0. 5 (mm)</p> <p>L= 5. 5 (mm)</p> <p>T=1. 0 (mm)</p>	L	5.5±0.1
	w	2.0±0.1
	T	1.0±0.1
	a	0.5±0.1

ELECTRICAL CHARACTERISTICS

CA-C03	Specification
Working Frequency Range	2450 ± 50MHz
Fc(GHz)	2.7GHz
Band Width	>100MHz
Impedance	50 Ω
Gain(dBi)	4.3 (peak)
VSWR	<2
Operation Temperature	-40°C~+95°C
Power Capacity	3W

The working frequency need be adjusted to 2.45GHz with matching circuit.

SOLDER LAND PATTERN DESIGN

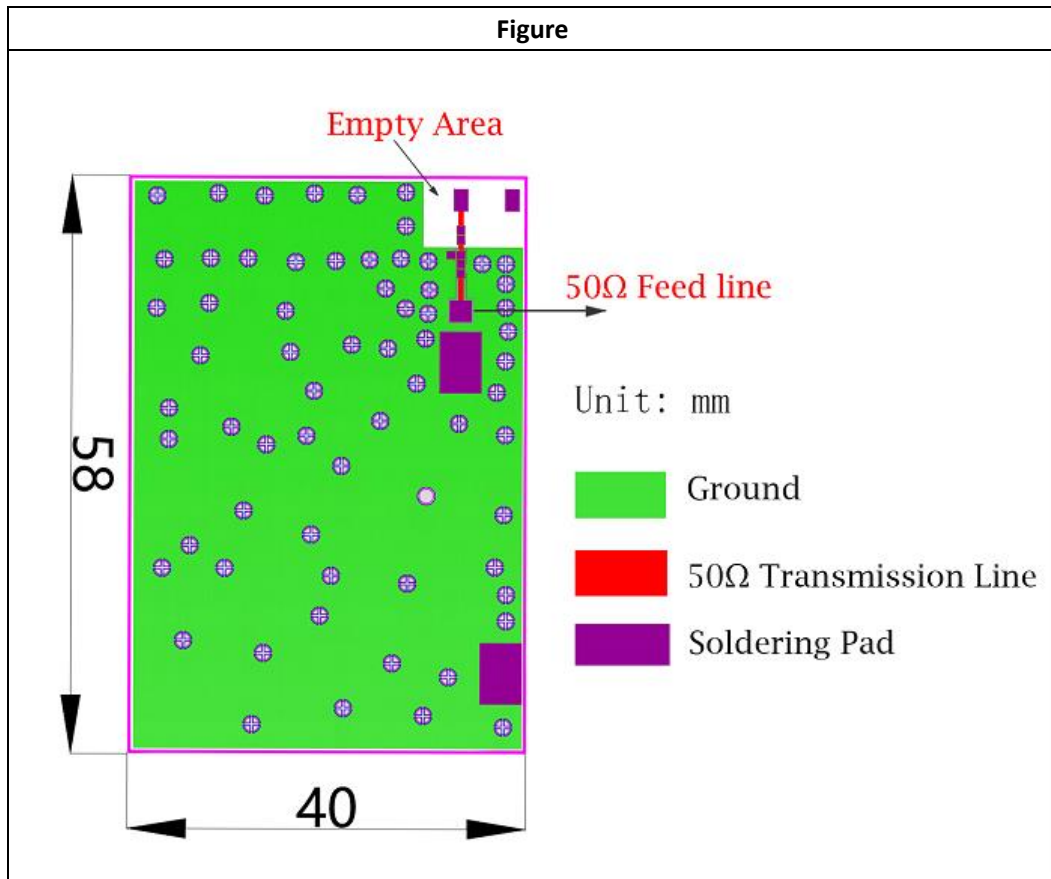

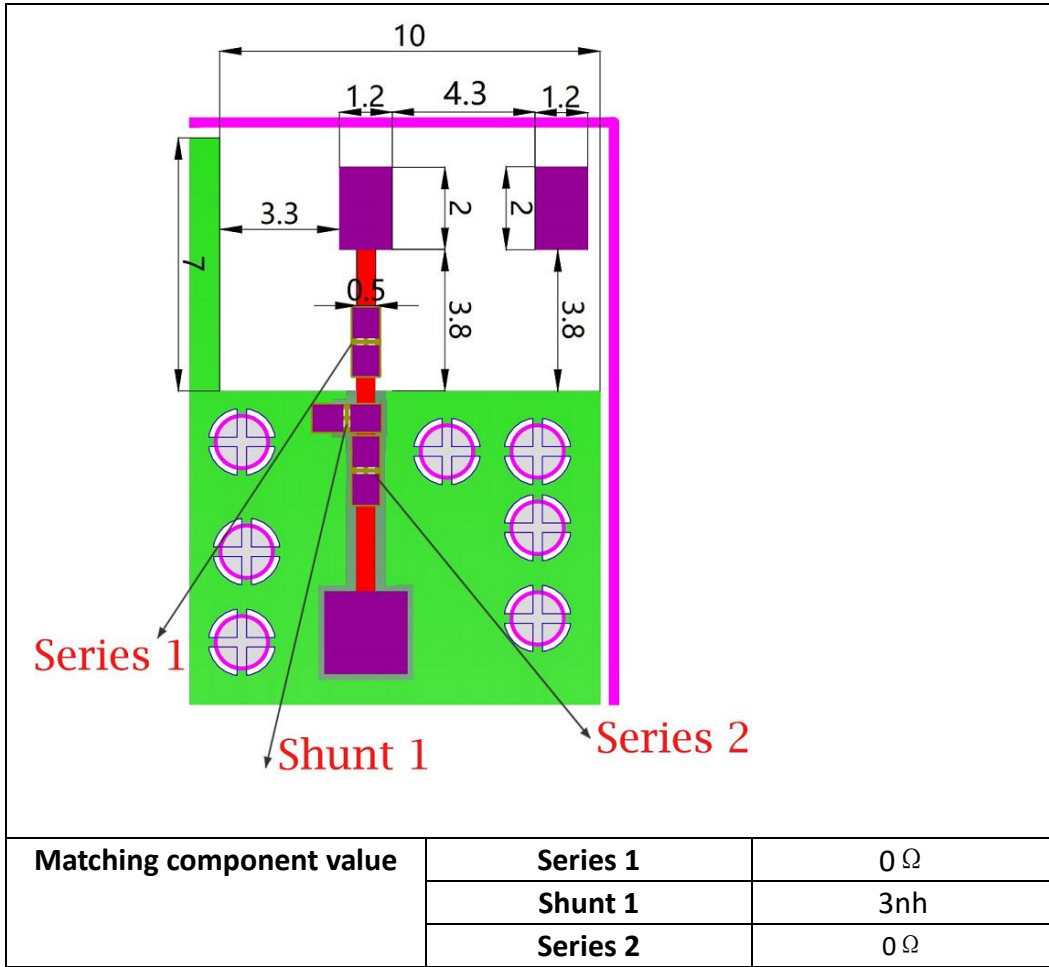

Antenna on Test Board (Thickness 1.0mm)

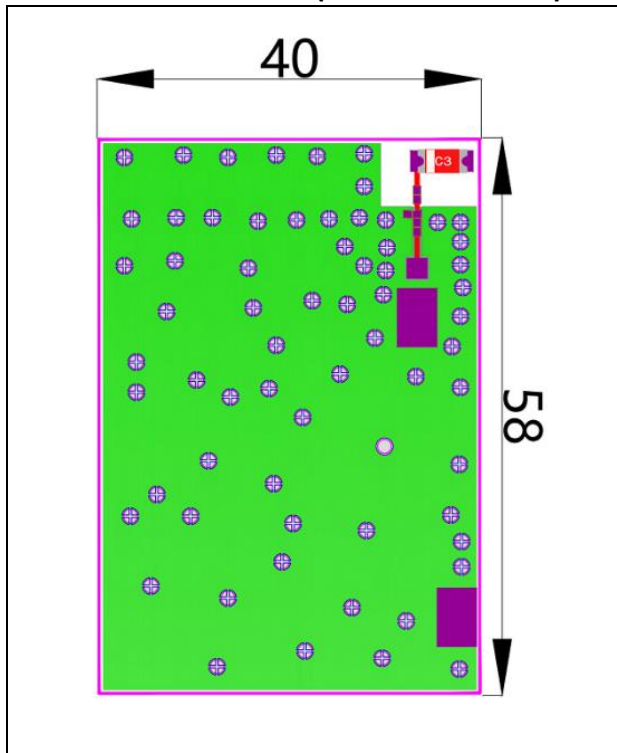

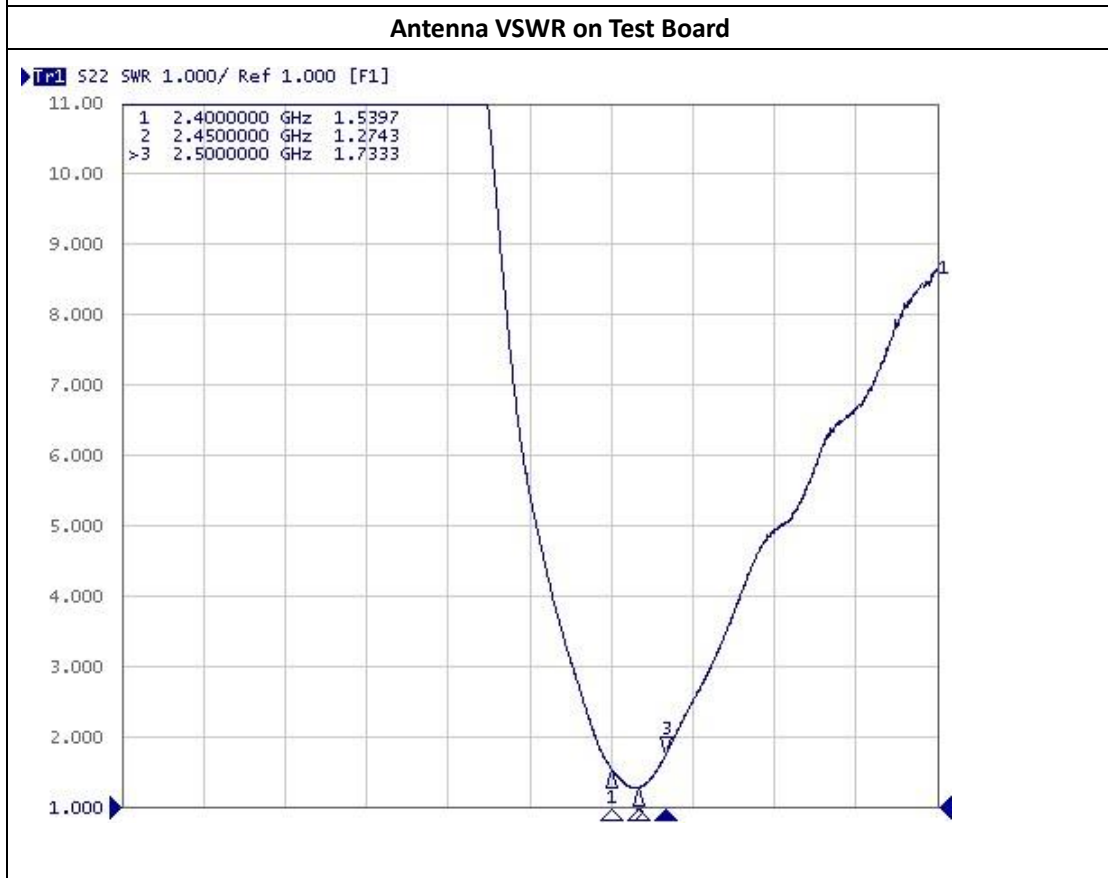
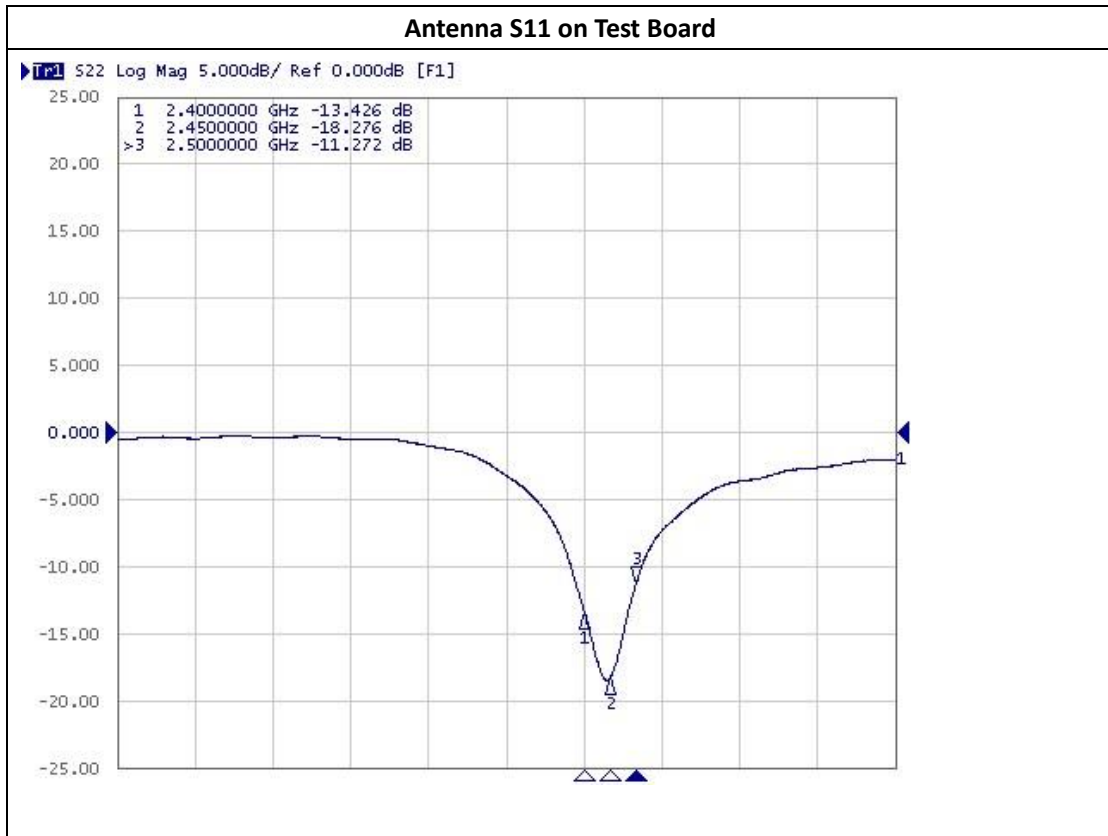

Efficiency and RADIATION PATTERN

Efficiency, Radiation Pattern and Gain were dependent on measurement board design. The

Approval sheet

specification of CA-C03 antenna was measured based on the PCB size and installation position as shown in the below figure test board. The test results were tested in ETS 3D Chamber.

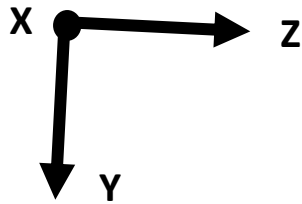
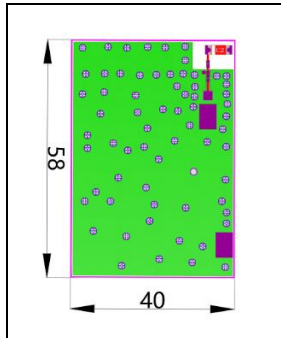

Gain and Efficiency	2.4G-2.5GHz
Peak Gain	4.3dBi
Average Gain across the band	4.1dBi
Gain Range across the band	3.9dBi~4.3dBi
Peak Efficiency	81.7%
Average Efficiency across the band	80.2%
Efficiency Range across the band	78.6%~81.7%

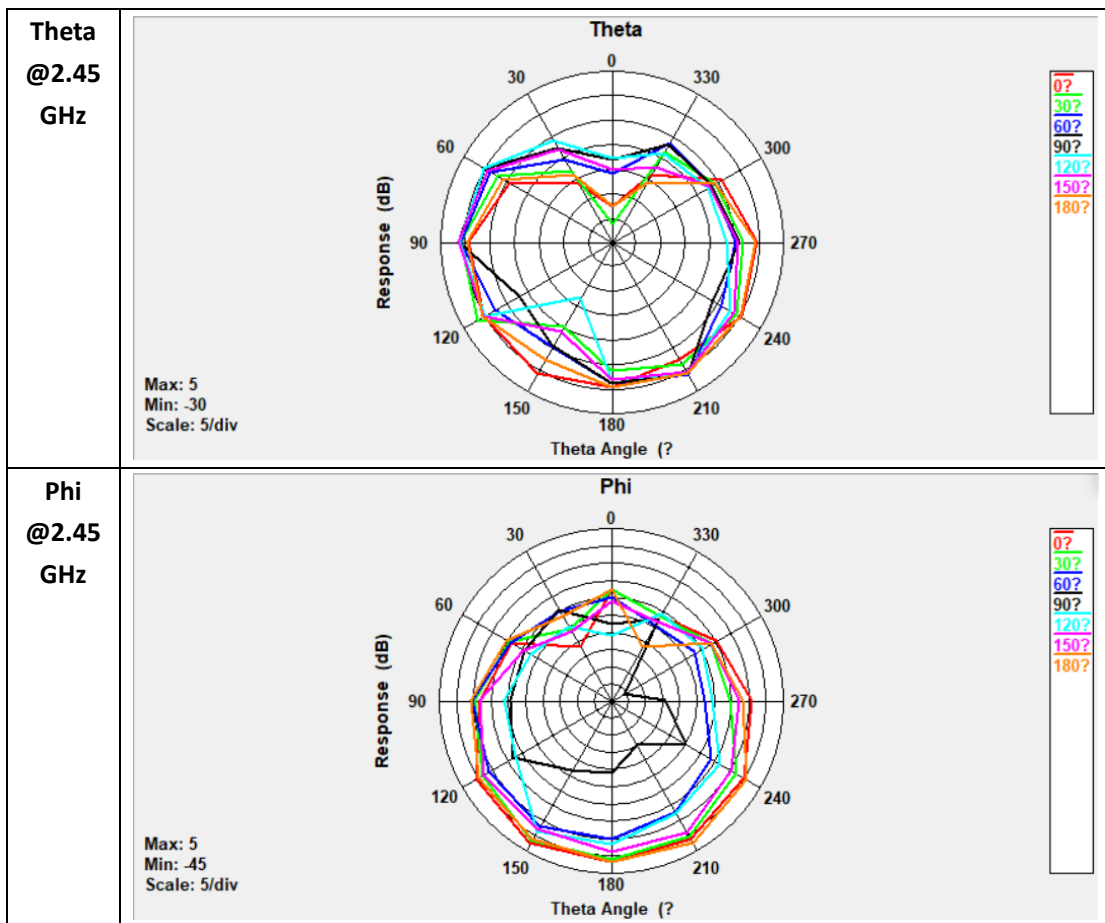

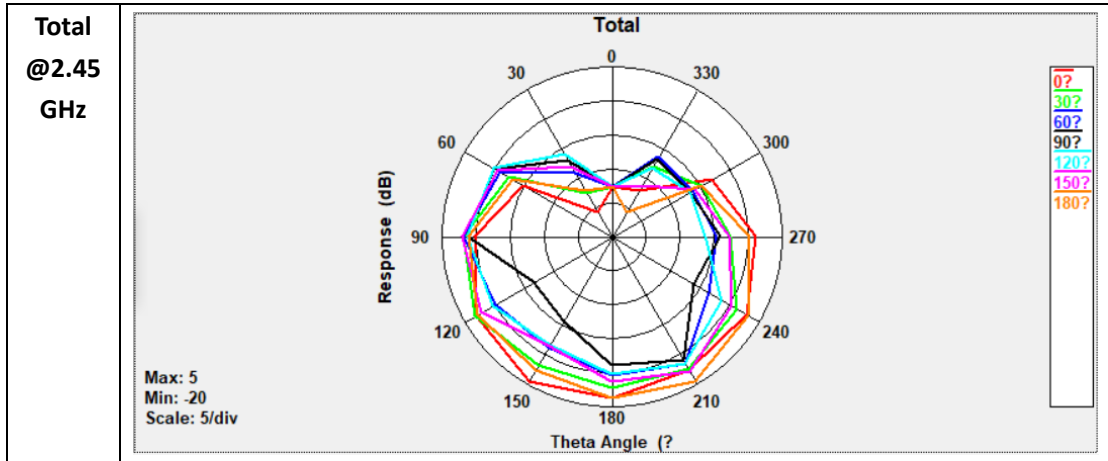

SOLDERING CONDITION

Typical examples of soldering processes that provide reliable joints without any damage is as follows:

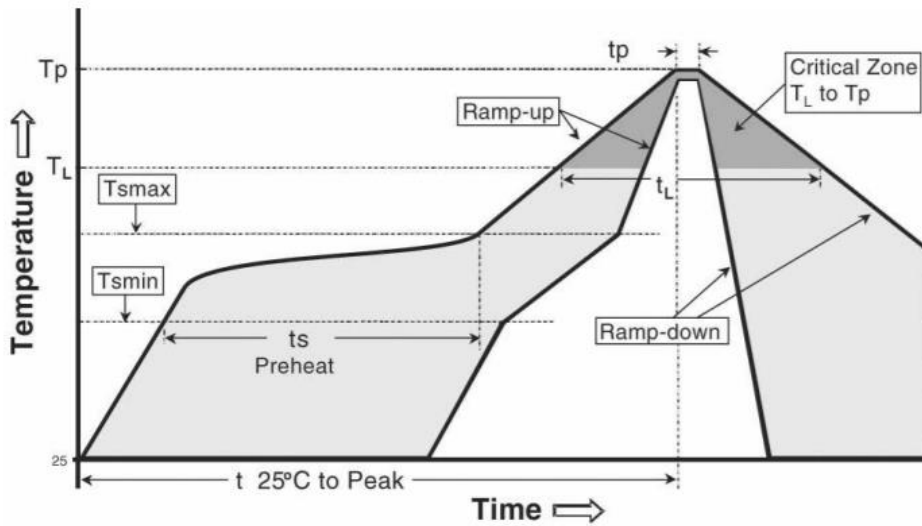

Phase	Profile features	Pb-Free assembly (SnAgCu)
RAMP-UP	Avg. Ramp-up Rate (Tsmax to Tp)	3 °C / second (max.)
PREHEAT	- Temperature Min (Tsmmin) - Temperature Max (Tsmax) - Time (tsmin to tsmax)	150 °C 200 °C 60-180 seconds
REFLOW	- Temperature (TL) - Total Time above TL (tL)	217 °C 60-150 seconds
PEAK	- Temperature (Tp) - Time (tp)	260 °C 20-40 seconds
RAMP-DOWN	Rate	6 °C/second max
Time from 25 °C to Peak Temperature		8 minutes max

PACKAGING

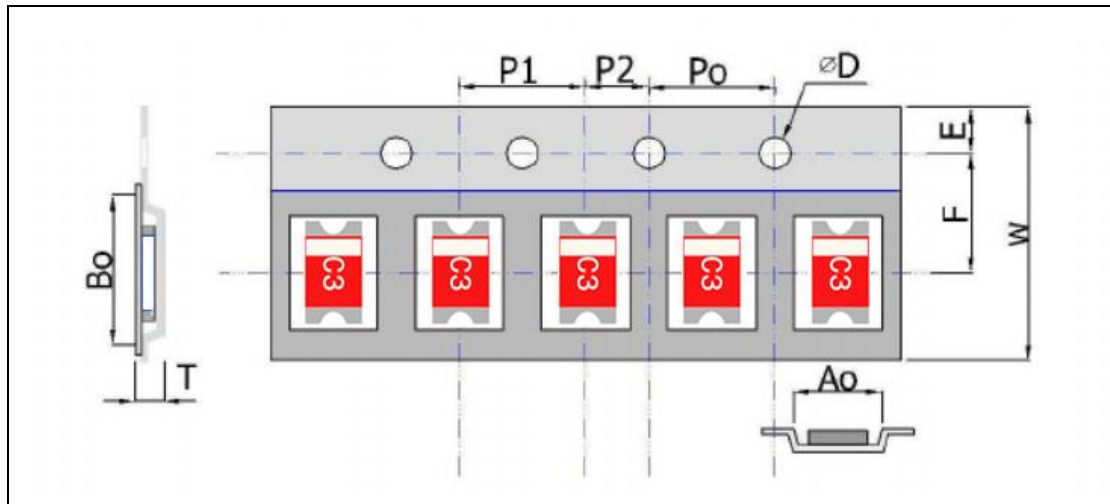

Plastic Tape specification (unit:mm)

Index	A_o	B_o	ΦD	T	W
Dimension (mm)	3.0 ± 0.1	6.0 ± 0.1	1.55 ± 0.05	1.2 ± 0.1	11.8 ± 0.1
Index	E	F	P_o	P_1	P_2
Dimension (mm)	1.75 ± 0.1	4.6 ± 0.1	4.0 ± 0.1	4.0 ± 0.1	2.0 ± 0.1

Reel dimensions

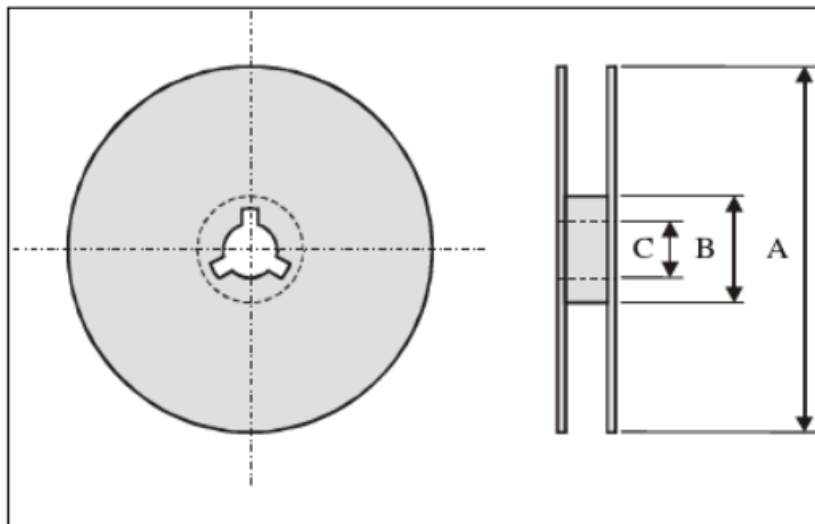

Index	A	B	C
Dimension(mm)	178	60	13.5

Typing Quantity: 3000 pieces per reel.

CAUTION OF HANDLING

Storage environment condition

Products should be storage in the warehouse on the following conditions:

Approval sheet

Temperature : -10°C~+40°C

Humidity : 30% to 70% relative humidity

Don't keep products in corrosive gases such as sulfur. Chlorine gas or acid or it may cause oxidization of electrode, resulting in poor solderability.

Products should be storage on the palette for the prevention of the influence from humidity, dust and so on.

Products should be storage in the warehouse without heat shock, vibration, direct sunlight and so on.

Products should be storage under the airtight packaged condition.