

Robot Vacuum cleaner

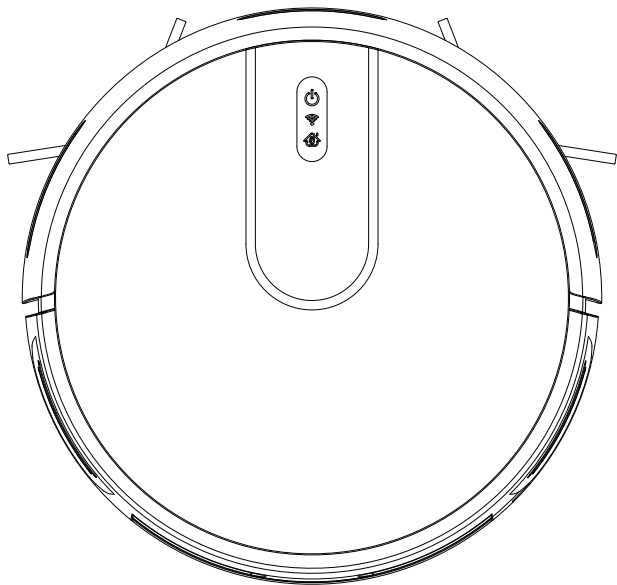

Instruction manual

Thank you for purchasing this product, please read the instructions carefully before use.

Product introduction

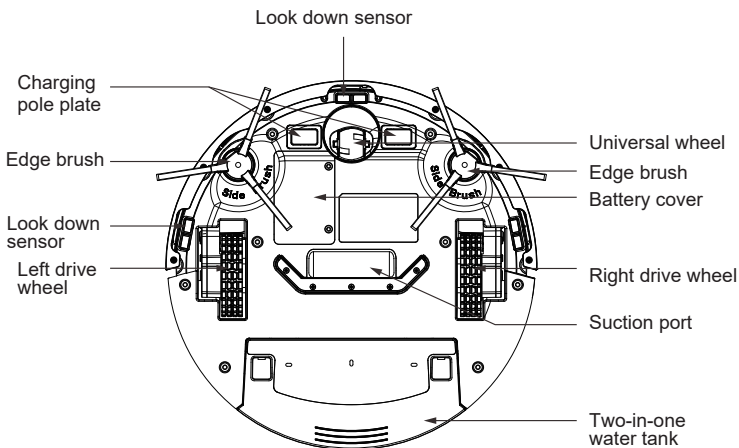
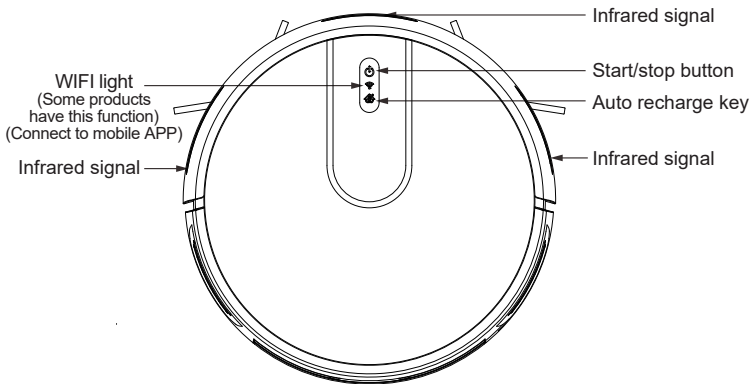

Product packaging and parameters

1. Product packaging list

Main engine (including battery) X 1
Power adapter X 1
Instruction manual X 1
Rag holder X 1

Charging dock X 1
Remote control X 1
Edge brush X 2
Cleaning brush X 1

Filter Hippa X 1
Permeable rag X 1
2-in-1 tank X 1

2. Technical parameters

Host machine

name	argument
Overall dimension	305x305x78mm
Rated voltage	7.4V
Rated power	15W
Charging time	About 4-6 hours
Cleaning time	≥ 90min
Dust box volume	400ML
Tank volume	250ML
Remote control distance	About 6 meters

adapter

name	argument
Input voltage	AC 100- 240V
Input frequency	50 - 60Hz
Output voltage	DC 12V
Output current	1A

* Due to the need for continuous improvement of the product, the company reserves the right to make any technical and design changes to the product, and the right of interpretation is reserved by the Company.

* There is no difference between the different models themselves, only a slight difference in color or appearance.

Charging guide

Charging base usage notice

Place the charging base and connect the power adapter. At this time, the power indicator on the charging base will turn on. During normal charging, the indicator light of the charging base will turn off.

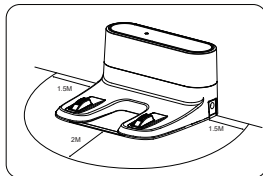

* Warm reminder



Place the charging seat against the wall and remove all obstacles 1.5 meters to the left and right of the charging seat and 2 meters in front, as shown in the figure.

Two charging methods

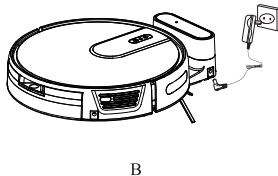
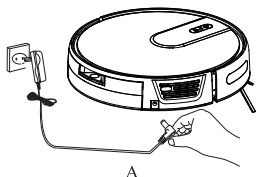
1. Connect the power adapter plug to the host to charge, as shown in Figure A. (Use only provided adapters)
2. use the charging base to charge the host, as shown in Figure B (the charging base is an accessory, if there is no charging base, please use figure A to charge).



* Warm reminder

- A. Please charge the machine for the first time for 12 hours,  key and  Key red breath,charging.After charging is complete, the green light of the  key will be on.
- B. When in regular use, please store the machine in the charging seat and ensure that the charging seat is connected to the power supply.
- C. If you do not use the machine for a long time, please fully charge the machine, turn off the power switch, and store it in a ventilated and dry place.
- D. When using the APP to set the reservation mode, do not use manual charging mode. Automatic charging mode is recommended.

Product use

1. how to use

① Install rags

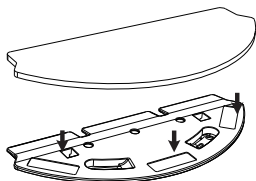

② remove or install the water tank Disassembly: hold down the red dot on the back, pull back, take out the water tank. Installation: Push the water tank horizontally along the host card slot until you hear a "click";

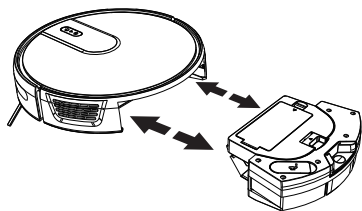

③ Open the tank cover and fill it with water

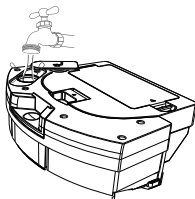

④ Install the cloth support to the bottom of the water tank until you hear a "click";

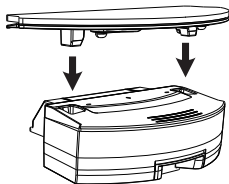

2. Turn on/off

① Turn it on

Press and hold the power button for 3 seconds until you hear a beep sound, the green light comes on, and the robot starts. Then the Wi-Fi indicator blinks and enters network mode. (Refer to the APP Guide for details)

② Turn it off

Long press the power button for 3 seconds, the green light is off, and the robot shuts down.

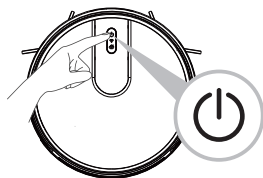

Remote control unit

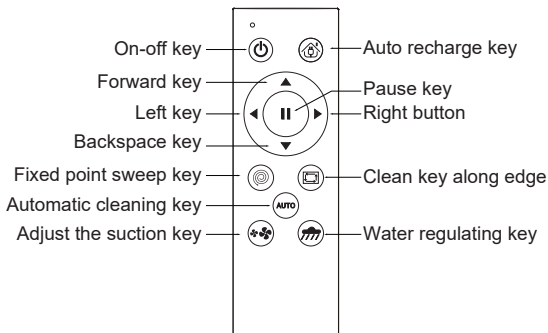

Precautions before use

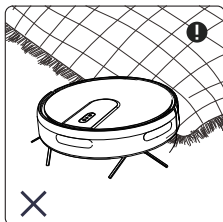

Fold the fringed edge of the carpet to prevent entanglement of the robot.

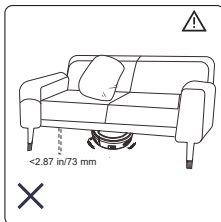

The robot cannot be used in a space lower than 73mm in height.

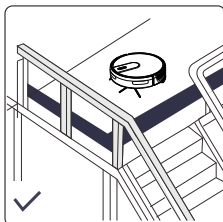

The machine should be used in a fenced environment to prevent the product from hanging and falling.

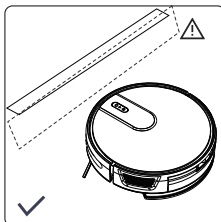

If they are dirty or used on reflective/dark colored floors, the effect may be reduced.

Machine cleaning guide

1. Clean the dust box and filter

Open the dust box button and clean up the trash.

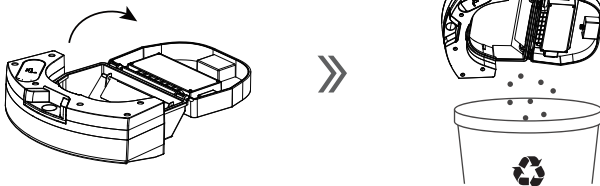

Remove the filter assembly and the high efficiency filter hiपा can be washed or patted to remove dust. After washing, please dry before use.

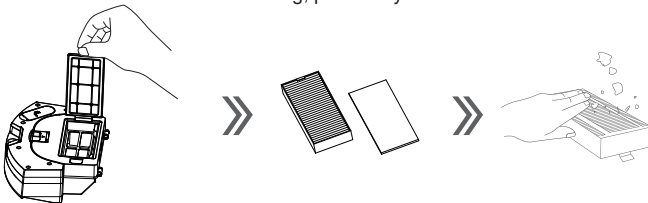

Wash the dust box and primary filter, air the dust box and filter assembly, and keep dry to ensure their service life.

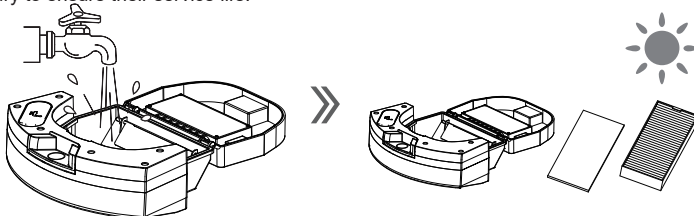

2. Clean water tank components

2.1 Disassembly and cleaning

Cleaning cloth

After mopping the floor, please take out the water storage tank, remove the cloth support and cloth, rinse and dry the cloth.



Clean water tank

After mopping the floor, take out the tank assembly, remove the rag, drain the remaining water in the tank, dry the tank and air.



2.2 Mop floor installation and use (some products with this function)

Insert the front end of the water tank into the mop, align the mop according to the figure, and attach the mop to the Velcro of the water tank.



Place the bottom of the machine facing up, align the positioning column of the water tank with the positioning hole of the drag plate at the bottom of the machine, and press the water tank tightly.

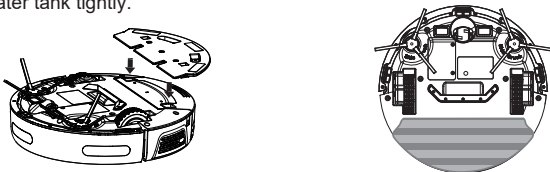

3. Clean other components

3.1 Edging brush

Take the bottom brush and wipe with a clean cleaning cloth.

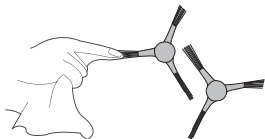

3.2 Clean the cardan wheel

Clean the wheel with a cleaning brush to reduce hair entanglement.

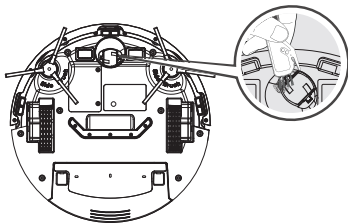

3.3 Clean the ground sensor

Clean the ground sensor to ensure sensor sensitivity.

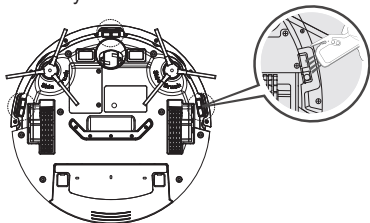

3.4 Clean the infrared sensor lens

Use a dry cloth to wipe the infrared sensor lens.

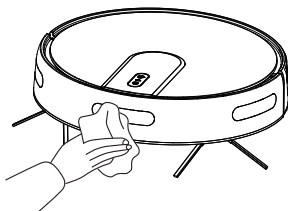

3.5 Clean the charging pole

Please use a dry cloth to clean the charging pad at the bottom of the console and the charging dock respectively.

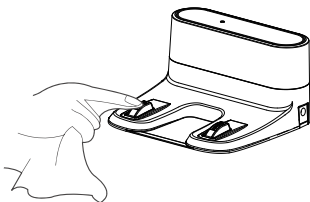
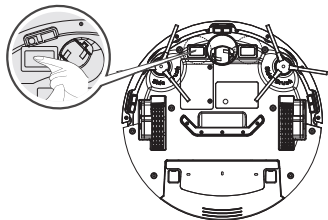

troubleshooting

Serial number	Fault condition	Possible cause	solution
1	The host cannot connect to the APP	The router user name and password are incorrect	Configure the router network and ensure that the user name and password are correct.
		The host is out of range of the router's network signal	Make sure the host is within the router's network signal coverage.
		Whether the host is in the state to be configured	You can configure the network of a host only when the host is in the state to be configured.
		The 2.4G network is not used.	The host does not support 5G network, please use 2.4G network for networking.
2	Main engine cannot be charged	The power adapter is not an original model.	Check whether the power adapter is the original model. The original power adapter model must be used
		The main engine is in poor contact with the charging pole plate of the charging base.	Ensure that the host is fully connected to the charging pole plate of the charging base. Check whether the charging pole sheet of the host and charging base is dirty, which can be cleaned by referring to the "Maintenance" chapter of the manual.
		The charging base is not connected to the power supply.	Make sure the charging base power supply is connected.
		The battery is not used for a long time, resulting in overdischarge.	It is recommended to use this product frequently. If it is not used for a long time, please contact after-sales service personnel.
3	The host cannot be recharged	The charging base is placed incorrectly.	Place the charging base correctly according to the method in the "Charging Operation" section of the manual.
		The charging base is powered off or artificially moved.	Please check that the charging base is connected to a power source. Do not manually move the charging base position.
		The host is stuck by ground obstacles (such as wires, carpet corners, fan bases, etc.) or the door of the room with the charging base is closed, resulting in the inability to return to the charging base.	It is recommended to refer to the instruction manual [Precautions] before using the host to clean up the ground items, ensure that the host runs smoothly, avoid stuck, and keep the recharge route smooth.
		The mainframe does not start cleaning from the charging base.	It is recommended to let the host start cleaning from the charging base.
4	When the main engine is working, the route is disorderly, running off, repeated cleaning and small area missing sweeping.	Objects such as wires and slippers placed on the ground affect the normal operation of the main engine.	Before the host work, please sort out the scattered wires, slippers and other objects on the ground to reduce the scattered items on the ground as much as possible. If there is a leakage phenomenon, the host will automatically repair the leakage, please do not intervene (such as moving the host or blocking the host route).
		Work on freshly waxed, polished floors, resulting in reduced friction between the drive wheels and the ground.	It is recommended that you wait for the floor wax to dry before using.
		Due to different home environments, the host in individual areas cannot be cleaned.	It is recommended to tidy up the home environment to ensure that the host can be cleaned.
5	The host is in trouble while working	The main engine is tangled or obstructed by scattered wires on the ground, sagging curtain fabric carpet edges, etc.	The master will try various methods to get out of the trap. If not, manual help is recommended.
		The main engine may be stuck by furniture that is close to the height of the main engine.	It is recommended to cushion the furniture or human cover.
6	The sound is loud when the host is working	Edge brush is entangled, dust box, filter material is blocked, etc.	It is recommended to regularly clean and maintain side brushes, dust boxes, filter materials, etc.
7	The main brush does not rotate	The main brush is tangled with hair.	Clean the tangled hair on the roller brush.
		The main brush and roller brush guard are not installed correctly.	Reinstall the roller brush assembly.
		Main brush assembly inhales foreign objects.	Remove the components and clean the foreign objects in the roller brush components.

8	Host fails to start	The host is powered off or the power switch is off.	Please charge the host or turn on the power switch.
	The main engine trembled when it walked.	The side brush or cardan is entangled with hair.	Please clean the side brush or cardan wound hair.
	The vacuuming effect is abnormal	The suction is blocked or the dust box is full of garbage.	Check the suction and clean the dust box.
		The high efficiency filter is blocked.	Clean or replace the high efficiency filter.
	Water tank failure	The water outlet hole of the water tank is blocked or the water tank is empty.	Please blow out the outlet hole and fill it with water.
		The pump doesn't work.	Please contact the company after sales maintenance.
	Main engine slip	The ground is too wet or too wet.	Please wring out the mop and clean the floor of water stains.
The mainframe keeps going backwards	The anti-drop sensor is abnormal.	Clean the surface of the anti-drop sensor.	
9	Even if the main machine is connected to a charging base, the robot does not charge	The power indicator on the charging base is off.	Please check that the charging base is properly connected to the socket.
		There is a foreign object on the charging terminal of the charging base.	If the power indicator is on, press the system reset button on the back of the unit and restart it.
			Remove any foreign matter attached to the charging terminal of the charging base and wipe it with a dry cloth.
10	The robot vacuum cleaner cannot access the companion application	Wireless network signals are not captured well.	Please check whether the product is in a place with good wireless network reception.
		The Internet is not working.	Please check whether the router used when registering the product has Internet access.
		The router has been changed.	After registering the product, check whether the router has changed, and if so, re-register the product.

If the fault cannot be removed according to the above operations, contact after-sales service personnel.

Warning code table

When there is a problem with the machine, it will emit a series of drops, while the red light flashes or long flashes.

1. Drip, the red light is on	Side wheel anomaly	Check the side wheel slot for foreign bodies and clean them up
2. Drip, red light flashing	Front jamming	Check for pre-collision jams, clean up foreign objects
3. Two drops, red light flashing	Edge brush anomaly	Check that the brush is not entangled with hair, and clean the brush
4. Three drops, red light flashing	The downview sensor is abnormal	Check if the sensor is dirty and wipe it clean with a rag
5. Four drops, red light flashing	Low current alarm	The robot runs out of power, please charge the robot

* Warm reminder

If the above methods do not solve the problem, please try the following actions:

1. Restart and restart the machine;
2. If restarting the machine does not solve the problem, please send the machine to the after-sales service center for repair.

List of hazardous substances in products

Component class	Harmful substance					
	key (Pb)	mercury (Hg)	cadmium (Cd)	Hexavalent chromium (CrVI)	Polybrominated biphenyls (PBB)	Polybrominated diphenyl ethers (PBDE)
shell	○	○	○	○	○	○
Circuit board	X	○	○	○	○	○
Electric machine	X	○	○	○	○	○
battery	○	○	○	○	○	○
attachments	X	○	○	○	○	○

This form is prepared in accordance with SJ/T 11364.

○: indicates that the content of the harmful substance in all homogeneous materials of the part is below the limit requirements specified in GB/T 26572.

X: indicates that the content of the hazardous substance in at least one homogeneous material of the part exceeds the limit requirements specified in GB/T26572.



Relevant certification

This product complies with SRRC certification, CMIT ID and model are listed on the device nameplate.

FCC Caution.

This device complies with part 15 of the FCC Rules. Operation is subject to the following two conditions:

- (1) This device may not cause harmful interference, and
- (2) this device must accept any interference received, including interference that may cause undesired operation.

Any Changes or modifications not expressly approved by the party responsible for compliance could void the user's authority to operate the equipment.

Note: This equipment has been tested and found to comply with the limits for a Class B digital device, pursuant to part 15 of the FCC Rules. These limits are designed to provide reasonable protection against harmful interference in a residential installation. This equipment generates uses and can radiate radio frequency energy and, if not installed and used in accordance with the instructions, may cause harmful interference to radio communications. However, there is no guarantee that interference will not occur in a particular installation. If this equipment does cause harmful interference to radio or television reception, which can be determined by turning the equipment off and on, the user is encouraged to try to correct the interference by one or more of the following measures:

- Reorient or relocate the receiving antenna.
- Increase the separation between the equipment and receiver.
- Connect the equipment into an outlet on a circuit different from that to which the receiver is connected.
- Consult the dealer or an experienced radio/TV technician for help.

*RF warning for Mobile device:

This equipment complies with FCC radiation exposure limits set forth for an uncontrolled environment. This equipment should be installed and operated with minimum distance 20cm between the radiator & your body.