

# Product Specifications

**Customer:**

**Customer P/N:**

手表硬磁线圈 14.15-0.08\*24-11T-6.6UH-L60MM+磁铁+BJ

**Checked: HAI**

**Approved : Eric**

**Date: 2020-03-10**

**CUSTOMER APPROVED 客户批准  
(SIGNATURE 签名)**



裕健智能  
E&J Intelligent

精研定制  
R&D customization

一、尺寸 DIMENSION:(mm)

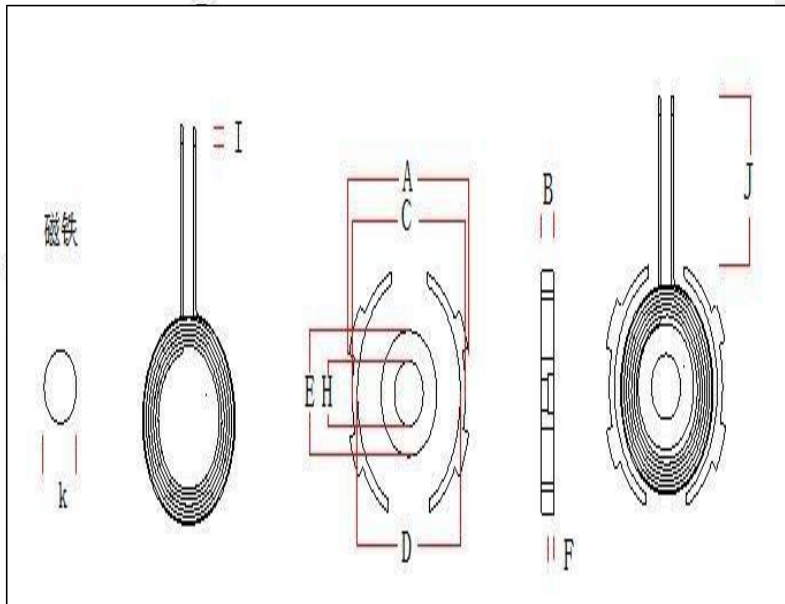

A	24.5±0.5
B	2.7±0.5
C	23.7±0.25
D	20.5±1
E	13.5±0.3
H	7.5±0.3
I	2±1
J	60±2
K	7.5*2.0

二、原理图 SCHEMATIC DIAGRAM:

序号 NO.	端子 TERMINAL		线径 WIRE	圈数 Turns	绕线方向 Winding Direction
1	S	F	热风线 0.08*24P	11TS	正常

三、绕线参数 Winding Specification:

四、电气特性 ELECTRICAL CHARACTERISTICS:

温度 TEMPERATURE:25 ±10°C, 湿度 RELATIVE HUMIDITY:65 ±20%

序号 NO.	项目 ITEM	端子 TERMINAL	标准 SPECIFICATION	测试条件 TEST FREQUENCY	测试仪器 TEST EQUIPMENTS
1	IND.	S-F	3.5uH ±20%单独线圈	100KHz/1V	LCZ METER 1062B
2	IND.	S-F	6.6uH ±10%加磁片	100KHz/1V	LCZ METER 1062B
3	Q 值	S-F	≥5	100KHz/1V	LCZ METER 1062B
4	DCR	S-F			

序号 number	材料名称 Material name	品名描述 Description	制造商 Manufacturer
1	漆包线 0.08*24 股	热风漆包线 0.08*24 股	
2	无铅锡条	无铅锡条	
3	磁片	Φ24.5*12.7mm 锰锌硬磁片	
4	胶水	201 胶水	
5	磁铁	7.5*2mm	
6	带孔双面胶	圆形直径 17mm(ref)背胶	

**Note: 备注**

Any other items which are not covered in this specification shall be agreed by both parties.  
本说明书未包括事项应由双方协议确定