

Product Specifications

Customer: Phone+Earphone-Φ43.5MMX0.8MM

Customer P/N:

G43.5*0.8-20.5-0.08*48-12T-10UH-W39.5-L50MM+BJ

Checked: HAI

Approved : Eric

Date: 2020-03-10

**CUSTOMER APPROVED 客户批准
(SIGNATURE 签名)**



裕健智能
E&J Intelligent

精研定制
R&D customization

一、尺寸 DIMENSION:(mm)

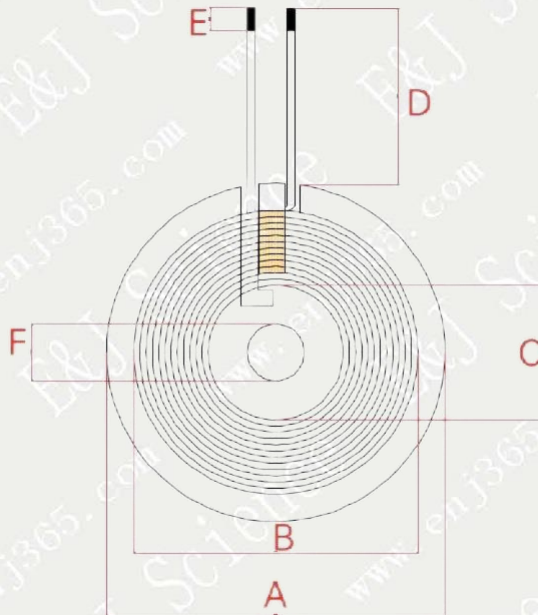

A	43.5 ± 0.5
B	39.5 ± 0.5
C	20.5 ± 0.5
D	50 ± 2
E	3 ± 2
F	5.3 ± 0.2
G	
H	
I	
K	

注：
 1.交叉出线;
 2.线圈贴 43.5 双槽磁片，磁片尺寸 43.5 ± 0.5mm，厚度为 0.8 ± 0.05mm.
 3.磁片背面贴背胶

二、原理图 SCHEMATIC DIAGRAM:

三、绕线参数 Winding Specification:

序号 NO.	端子 TERMINAL		线径 WIRE	圈数 Turns	绕线方向 Winding Direction
1	S	F	丝包线 0.08*48P	12Ts	CCW

四、电气特性 ELECTRICAL CHARACTERISTICS:

温度 TEMPERATURE: 25 ± 10°C, 湿度 RELATIVE HUMIDITY: 65 ± 20%

序号 NO.	项目 ITEM	端子 TERMINAL	标准 SPECIFICATION	测试条件 TEST FREQUENCY	测试仪器 TEST EQUIPMENTS
1	IND.	S-F	7.3uH ± 10% 单独线圈	100KHz/1.0V	LCZ METER 1062B
2	IND.	S-F	10UH ± 10% 加磁片	100KHz/1.0V	LCZ METER 1062B
3	DCR	S-F	≤ 40mΩ		LCZ METER 502B

Note: 备注

Any other items which are not covered in this specification shall be agreed by both parties.
 本说明书未包括事项应由双方协议确定