

深圳市三盛创电子科技有限公司

Shenzhen Sansheng Chuang electronic Technology Co., LTD

承 認 書

客 戶:
CUSTOMER: 中立冠达【深圳】智能有限公司

客 戶 料 號:
CUST P/N: ZLGD-A1-0326

三盛创 料 號:
FINE P/N: I40-6.5uH single coil 0.08*24P*2P*11TS

產 品 型 號:
DESC: Φ 40MMX5.3MMX0.8MM slotting

日 期:
DATE: 2024.05.13

版 本:
Version: A.0

擬制 PREPARED BY	審核 CHECKED BY	批准 APPROVED BY	客戶承認 CUSTOMER APPROVE
郭柳	安帅印	安帅印	

深圳市三盛创电子科技有限公司

Shenzhen Sansheng Chuang electronic Technology Co., LTD

工廠地址: 深圳市光明区玉塘街道玉律社区大洋一路 19 号 2 楼

Factory address: 2nd Floor, No. 19, Dayang Road, Yulu Community, Yutang Street, Guangming District, Shenzhen

SPECIFICATION

產品型號: DESC	Φ 20.5x38-7.7uH-0.08*24P-5mm	版本 Rev: A.0	客戶 CUST: 客戶料号 CUST P/N:	中立冠达 ZLGD-A1-0326
---------------	------------------------------	----------------	----------------------------	----------------------

一、尺寸 DIMENSION:(mm)

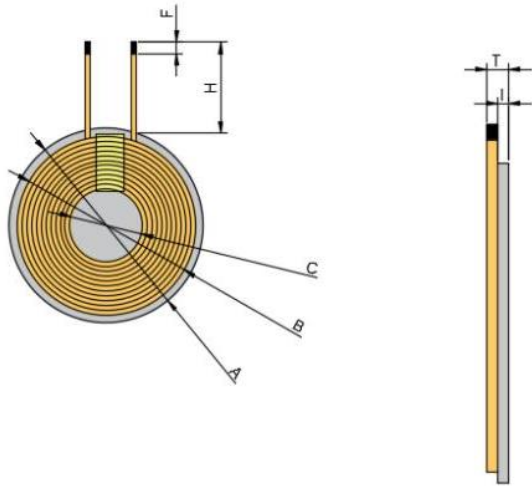

A	40±0.5
B	38±1.0
C	20.5±0.5
F	3±1.0
H	5±1.5
I	0.8±0.1
T	1.8±0.2

Note:

- Cross out wire;
- Wrap 5mm(ref) width high-temperature adhesive paper 1-2Ts around the cable outlet position.
- The coil is attached to the circular hard magnetic disc with groove, the magnetic disc size is 40±0.5mm, the inner hole is 5.3mm, and the thickness is 0.8±0.1mm.

二、原理图 SCHEMATIC DIAGRAM:

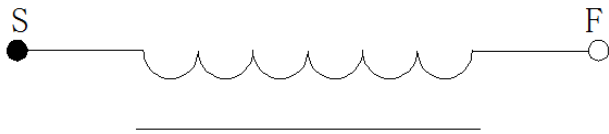

三、绕线参数 Winding Specification:

序号 NO.	端子 TERMINAL	线径 WIRE	圈数 Turns	绕线方向 Winding Direction
1	S F	Hot air wire 0.08*24P	11Ts	CCW

四、电气特性 ELECTRICAL CHARACTERISTICS:

温度 TEMPERATURE:25±10℃, 湿度 RELATIVE HUMIDITY:65±20%

序号 NO.	项目 ITEM	端子 TERMINAL	标准 SPECIFICATION	测试条件 TEST FREQUENCY	测试仪器 TEST EQUIPMENTS
1	IND.	S-F	4.8uH ±10% Individual coil	100KHz/1.0V	LCZ METER 1062B
2	IND.	S-F	7.7uH ±10% Magnetized sheet	100KHz/1.0V	LCZ METER 1062B
3	DCR	S-F	≤99mΩ	100KHz/1.0V	LCZ METER 502B
4	Q	S-F	≥40	100KHz/1.0V	LCZ METER 502B

擬制/日期 PREPARED BY/DATE

審核/日期 CHECKED BY/DATE

郭柳 2024.05.13

安帅印 2024.05.13

天线增益 Antenna gain:

Operation frequency:	300kHz-350kHz
Antenna Type:	Loop coil Antenna
Antenna gain:	0dBi