



## EMC TEST REPORT

Product Name: Radio

FCC ID: 2BG9P-YX318

Trade mark: NITIGO

Model No.: YX-318

S/N: /

Report No.: CTB240626028EX

Applicant: Zhongshan YouXin Electronic Technology Co., Ltd.

Address: Zone D, Second Floor, Building A, NO.4 Jinkun Street, Pingnan Village, Sanxiang Town, Zhongshan City, Guangdong Province, China

Manufacturer: Zhongshan YouXin Electronic Technology Co., Ltd.

Address: Zone D, Second Floor, Building A, NO.4 Jinkun Street, Pingnan Village, Sanxiang Town, Zhongshan City, Guangdong Province, China

Prepared by: Shenzhen CTB Testing Technology Co., Ltd.

Address: 1&2/F., Building A, No.26, Xinhe Road, Xinqiao, Xinqiao Street, Bao'an District, Shenzhen, Guangdong, China

Date of Receipt: Jun. 14, 2024

Date of Test(s): Jun. 14, 2024 ~ Jun. 26, 2024

Date of Issue: Jun. 26, 2024

Test Standard(s): CFR47, FCC Part 15 Subpart B, ANSI C63.4: 2014

Test Result: Pass

In the configuration tested, the EUT complied with the standards specified above.

Compiled by:

Michael Niu

Reviewed by:

Bin Mei

Approved by:



Rita Xiao

Note: If there is any objection to the inspection results in this report, please submit a written report to the company within 15 days from the date of receiving the report. The test report is effective only with both signature and specialized stamp. This result(s) shown in this report refer only to the sample(s) tested. Without written approval of Shenzhen CTB Testing Technology Co., Ltd. this report can't be reproduced except in full. The tested sample(s) and the sample information are provided by the client. "★" indicates the testing items were fulfilled by subcontracted lab. "×" indicates the items are not in CNAS accreditation scope.

## Table of Contents

1.	Description of version .....	3
2.	Test summary .....	4
3.	Measurement uncertainty .....	5
4.	General information .....	6
4.1.	Description of EUT .....	6
4.2.	Description of accessory device .....	6
4.3.	Test conditions .....	6
4.4.	Block diagram of EUT configuration .....	6
4.5.	Operating condition of EUT .....	6
5.	List of Test and Measurement Instruments .....	7
6.	Conducted Emission .....	8
6.1.	Limit .....	8
6.2.	Test setup .....	8
6.3.	EMI test receiver setup .....	8
6.4.	Test procedure .....	8
6.5.	Test results .....	9
7.	Radiated emissions .....	11
7.1.	Limit .....	11
7.2.	Test setup .....	11
7.3.	EMI test receiver setup and spectrum analyzer setup .....	12
7.4.	Test procedure .....	12
7.5.	Corrected Amplitude & Margin Calculation .....	12
7.6.	Test results .....	13
8.	Photographs of test setup .....	15

## 1. Description of version

Report No.	Issue Date	Description	Approved
CTB240626028EX	Jun. 26, 2024	Original	Valid

## 2. Test summary

Test procedures according to the technical standards:

Standard	Test Item	Test Result
§15.107	Conducted Emission	PASS
§15.109	Radiated Emission	PASS

### 3. Measurement uncertainty

The reported uncertainty of measurement  $y \pm U$ , where expanded uncertainty  $U$  is based on a standard uncertainty multiplied by a coverage factor of  $k=2$ , providing a level of confidence of approximately 95 %

Test Item	Frequency	Expanded Uncertainty ( $U_{Lab}$ )
Conducted Emission	150 kHz to 30 MHz	$\pm 3.1$ dB
Radiated Emission	30 MHz to 1000 MHz	$\pm 4.1$ dB
Radiated Emission	1000 MHz to 6000 MHz	$\pm 4.8$ dB

## 4. General information

### 4.1. Description of EUT

Product name	Radio
Trade mark	NITIGO
Model No.	YX-318
Serial Model No.	N/A
Model Difference	N/A
Configuration	<input checked="" type="checkbox"/> Table-top <input type="checkbox"/> Floor-standing
The highest frequency of the internal sources of the EUT	<input type="checkbox"/> below 1.705 MHz, the measurement shall only be made up to 30 MHz. <input checked="" type="checkbox"/> between 1.705 MHz and 108 MHz, the measurement shall only be made up to 1 GHz. <input type="checkbox"/> between 108 MHz and 500 MHz, the measurement shall only be made up to 2 GHz. <input type="checkbox"/> between 500 MHz and 1 GHz, the measurement shall only be made up to 5 GHz. <input type="checkbox"/> above 1 GHz, the measurement shall be made up to 5th harmonic of the highest frequency or 40 GHz, whichever is lower.

**Note:** The above EUT information is declared by manufacturer and for more detailed features description, please refer to the manufacturer's specifications or the User's Manual.

### 4.2. Description of accessory device

No.	Device Type	Brand	Model	Specification	Note
1	Adapter	JIYIN	JY-05100C	/	/

### 4.3. Test conditions

Temperature: 15-25°C  
 Relative Humidity: 30-60 %  
 Atmospheric pressure: 800hPa-1060hPa

### 4.4. Block diagram of EUT configuration

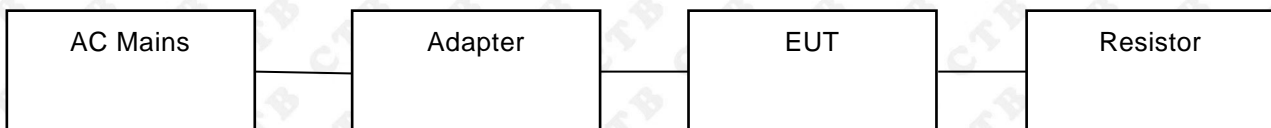

### 4.5. Operating condition of EUT

Operating condition	Mode 1	Working	Test Voltage	/
Note: This test covers all possible operating modes of the device, only the worst data are list in report. The worst data are shows (*) is the nearest standard limit which were recorded in this report.				

**5. List of Test and Measurement Instruments**

Continuous disturbance					
No.	Equipment	Manufacturer	Model No.	Serial No.	Calibrated until
1	843 Shield Room	C/ R/ T	843	/	2024/8/11
2	AMN	ROHDE&SCHWARZ	ESH3-Z5	831551852	2024/7/04
3	Pulse limiter	ROHDE&SCHWARZ	ESH3Z2	357881052	2024/7/04
4	EMI TEST RECEIVER	ROHDE&SCHWARZ	ESCS30	834115/006	2024/7/04
5	Coaxial cable	ZDECL	Z302S	18091904	2024/7/04
6	AAN	Schwarzbeck	NTFM8158	183	2024/7/07
7	EZ-EMC	Frad	EMC-con3A1.1	/	/

Radiated emission					
No.	Equipment	Manufacturer	Model No.	Serial No.	Calibrated until
1	966 Chamber	C/ R/ T	966	/	2024/8/11
2	Double Ridged Broadband Horn Antenna	Schwarzbeck	BBHA 9120D	1911	2026/7/07
3	TRILOG Broadband Antenna	Schwarzbeck	VULB 9168	869	2024/7/07
4	Amplifier	Agilent	8449B	3008A01838	2024/7/04
5	Amplifier	HP	8447E	2945A02747	2024/7/04
6	EMI TEST RECEIVER	ROHDE&SCHWARZ	ESPI7	100362	2024/7/04
7	Coaxial cable	ETS	RFC-SNS-100-NMS-80 NI	/	2024/7/04
8	Coaxial cable	ETS	RFC-SNS-100-NMS-20 NI	/	2024/7/04
9	Coaxial cable	ETS	RFC-SNS-100-SMS-20 NI	/	2024/7/04
10	Coaxial cable	ETS	RFC-NNS-100-NMS-300 NI	/	2024/7/04
11	EZ-EMC	Frad	EMC-con3A1.1	/	/

## 6. Conducted Emission

### 6.1. Limit

Except for Class A devices:

Frequency of emission (MHz)	Conducted limit (dB $\mu$ V)	
	Quasi-peak	Average
0.15-0.5	66 to 56*	56 to 46*
0.5-5	56	46
5-30	60	50

**Note:** Decreases with the logarithm of the frequency.

For Class A devices:

Frequency of emission (MHz)	Conducted limit (dB $\mu$ V)	
	Quasi-peak	Average
0.15-0.5	79	66
0.5-30	73	60

### 6.2. Test setup

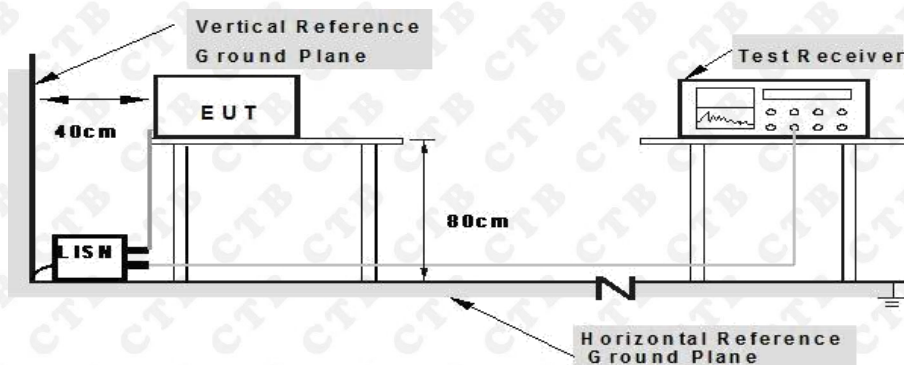

**Note: 1.** Support units were connected to second LISN.

**2.** Both of LISNs (AMN) are 80 cm from EUT and at least 80 from other units and other metal planes

The setup of EUT is according with ANSI C63.4 measurement procedure. Specification used with FCC Part 15 limits.

### 6.3. EMI test receiver setup

Frequency Range	9kHz-30MHz
Resolution Bandwidth	200Hz (9kHz-150kHz) 9kHz (150kHz-30MHz)

### 6.4. Test procedure

1. Measurement was performed in shielded room, and instruments used were followed clause 4 of ANSI C63.4.
2. Detailed test procedure was following clause 7 of ANSI C63.4.
3. Frequency range 150kHz – 30MHz was checked and EMI receiver measurement bandwidth was set to 9 kHz.



## 6.5. Test results

Temperature:	23°C	Relative Humidity:	54 %
Pressure:	101kPa	Phase :	Line
Test Voltage :	AC 120V/60Hz	Test Mode:	Mode 1

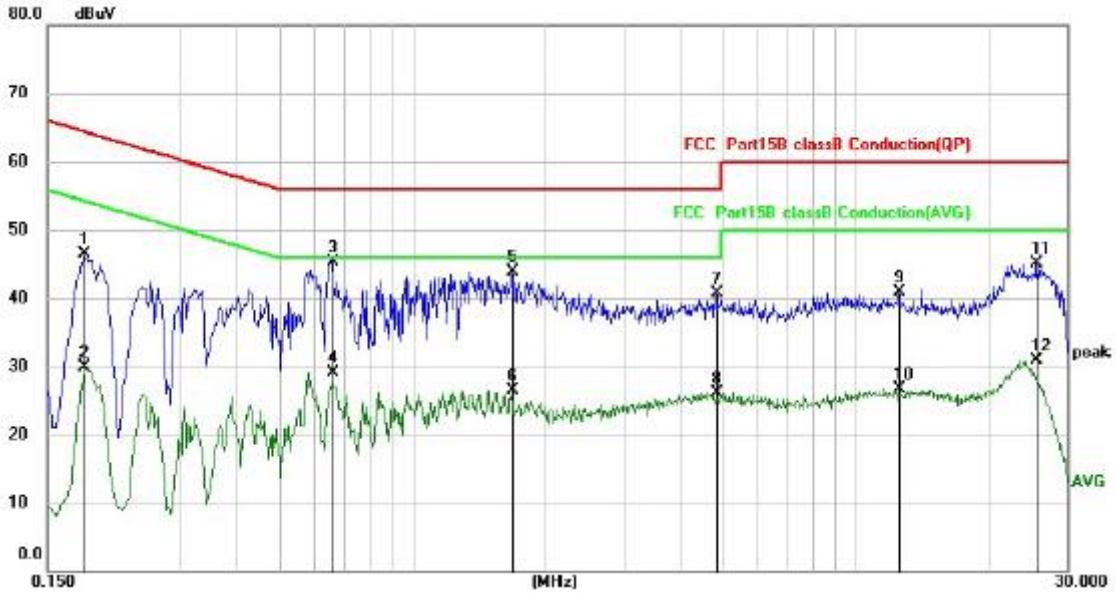

No.	Mk.	Freq.	Reading Level	Correct Factor	Measurement	Limit	Over	Detector
		MHz	dBuV	dB	dBuV	dBuV	dB	
1		0.1819	36.48	9.95	46.43	64.40	-17.97	QP
2		0.1819	19.89	9.95	29.84	54.40	-24.56	AVG
3	*	0.6580	35.26	10.01	45.27	56.00	-10.73	QP
4		0.6580	19.17	10.01	29.18	46.00	-16.82	AVG
5		1.6780	33.83	10.06	43.89	56.00	-12.11	QP
6		1.6780	16.36	10.06	26.42	46.00	-19.58	AVG
7		4.8260	30.31	10.36	40.67	56.00	-15.33	QP
8		4.8260	15.84	10.36	26.20	46.00	-19.80	AVG
9		12.5140	30.29	10.66	40.95	60.00	-19.05	QP
10		12.5140	15.95	10.66	26.61	50.00	-23.39	AVG
11		25.5180	34.03	11.05	45.08	60.00	-14.92	QP
12		25.5180	19.88	11.05	30.93	50.00	-19.07	AVG

Note: Result=Reading + Factor  
Over Limit=Result - Limit

Temperature:	23°C	Relative Humidity:	54 %
Pressure:	101kPa	Phase :	Neutral
Test Voltage :	AC 120V/60Hz	Test Mode:	Mode 1

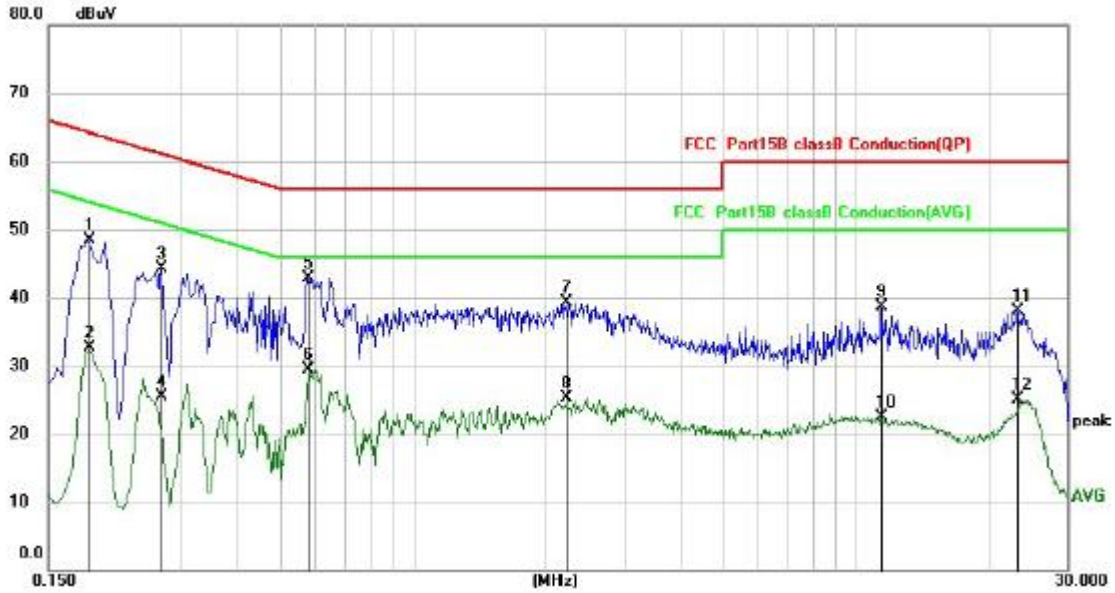

No.	Mk.	Freq. MHz	Reading Level dBuV	Correct Factor dB	Measure- ment dBuV	Limit dBuV	Over dB	Detector
1		0.1860	38.63	9.95	48.58	64.21	-15.63	QP
2		0.1860	22.73	9.95	32.68	54.21	-21.53	AVG
3		0.2700	34.32	9.96	44.28	61.12	-16.84	QP
4		0.2700	15.52	9.96	25.48	51.12	-25.64	AVG
5	*	0.5780	32.94	10.00	42.94	56.00	-13.06	QP
6		0.5780	19.52	10.00	29.52	46.00	-16.48	AVG
7		2.2180	29.13	10.11	39.24	56.00	-16.76	QP
8		2.2180	15.23	10.11	25.34	46.00	-20.66	AVG
9		11.3900	28.07	10.62	38.69	60.00	-21.31	QP
10		11.3900	11.87	10.62	22.49	50.00	-27.51	AVG
11		23.1100	27.14	10.94	38.08	60.00	-21.92	QP
12		23.1100	14.10	10.94	25.04	50.00	-24.96	AVG

Note: Result=Reading + Factor  
Over Limit=Result – Limit

## 7. Radiated emissions

### 7.1. Limit

Except for Class A devices (at 3m):

Frequency of emission (MHz)	Field strength (microvolts/meter)	
	(microvolts/meter)	(dB $\mu$ V/m)
30-88	100	40
88-216	150	43.5
216-960	200	46
Above 960	500	54

For Class A devices (at 10m):

Frequency of emission (MHz)	Field strength (microvolts/meter)	
	(microvolts/meter)	(dB $\mu$ V/m)
30-88	90	39
88-216	150	43.5
216-960	210	46.4
Above 960	300	49.5

### 7.2. Test setup

Radiated Emission Test Set-Up Frequency Below 1 GHz

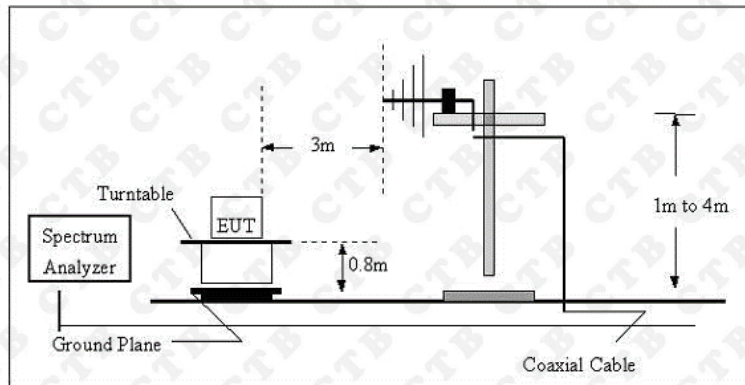

Radiated Emission Test Set-Up Frequency Above 1GHz

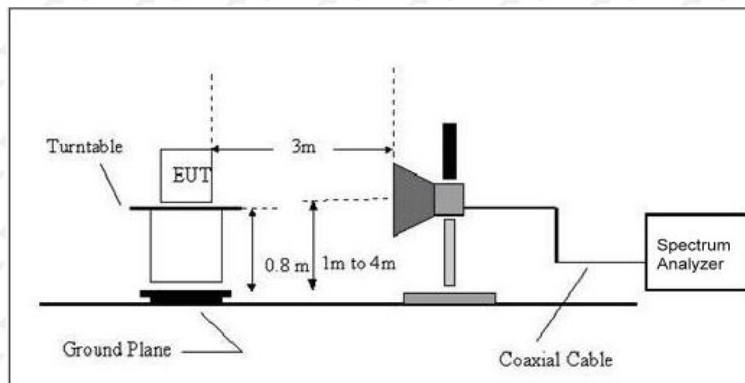

The radiated tests were performed in 3 meter Chamber test site, using the setup accordance with the ANSI C63.4:2014.

### 7.3. EMI test receiver setup and spectrum analyzer setup

During the radiated emission test, the EMI test receiver and Spectrum Analyzer were set with the following configurations:

Frequency Range	RBW	Video B/W	IF B/W	Detector
30MHz-1000MHz	100kHz	300kHz	120kHz	QP
Above 1GHz	1MHz	3MHz	/	PK
	1MHz	10Hz	/	AVG

### 7.4. Test procedure

1. The measurement was performed in a semi-anechoic chamber, and instruments used were followed clause 4 of ANSI C63.4
2. Detailed test procedure was following clause 8 of ANSI C63.4.

### 7.5. Corrected Amplitude & Margin Calculation

1. The Corrected Amplitude is calculated by adding the Antenna Factor and Cable Loss, and subtracting the Amplifier Gain from the Meter Reading. The basic equation is as follows:

$$\text{Corrected Amplitude} = \text{Meter Reading} + \text{Antenna Factor} + \text{Cable Loss} - \text{Amplifier Gain}$$

2. The "Margin" column of the following data tables indicates the degree of compliance with the applicable limit. For example, a margin of 7dB means the emission is 7dB below the limit. The equation for margin calculation is as follows:

$$\text{Margin} = \text{Limit} - \text{Corrected Amplitude}$$

## 7.6. Test results

Temperature:	23°C	Relative Humidity:	54 %
Pressure:	101kPa	Polarization :	Horizontal
Test Voltage :	AC 120V/60Hz	Test Mode:	Mode 1

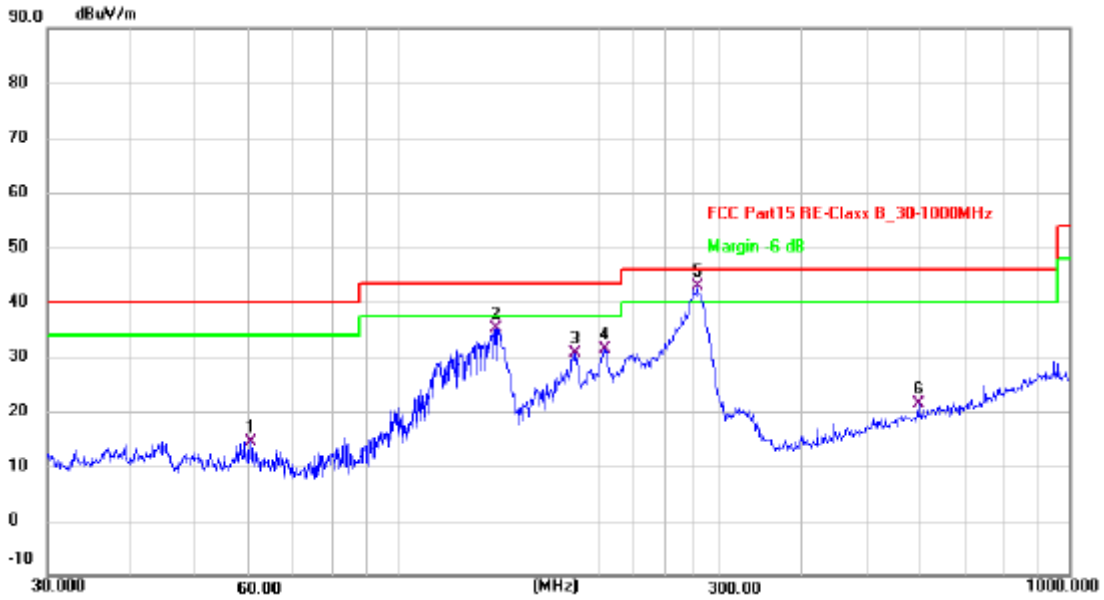

No.	Frequency (MHz)	Reading (dBUV)	Factor (dB/m)	Level (dBUV/m)	Limit (dBUV/m)	Margin (dB)	Detector
1	60.2801	29.66	-15.32	14.34	40.00	-25.66	QP
2	139.8508	48.93	-13.79	35.14	43.50	-8.36	QP
3	183.8440	46.19	-15.63	30.56	43.50	-12.94	QP
4	203.5228	47.59	-16.28	31.31	43.50	-12.19	QP
5 *	279.0436	57.03	-14.11	42.92	46.00	-3.08	QP
6	595.1329	26.79	-5.49	21.30	46.00	-24.70	QP

Note: Result=Reading+Factor  
Over Limit=Result-Limit

Temperature:	23°C	Relative Humidity:	54 %
Pressure:	101kPa	Polarization :	Vertical
Test Voltage :	AC 120V/60Hz	Test Mode:	Mode 1

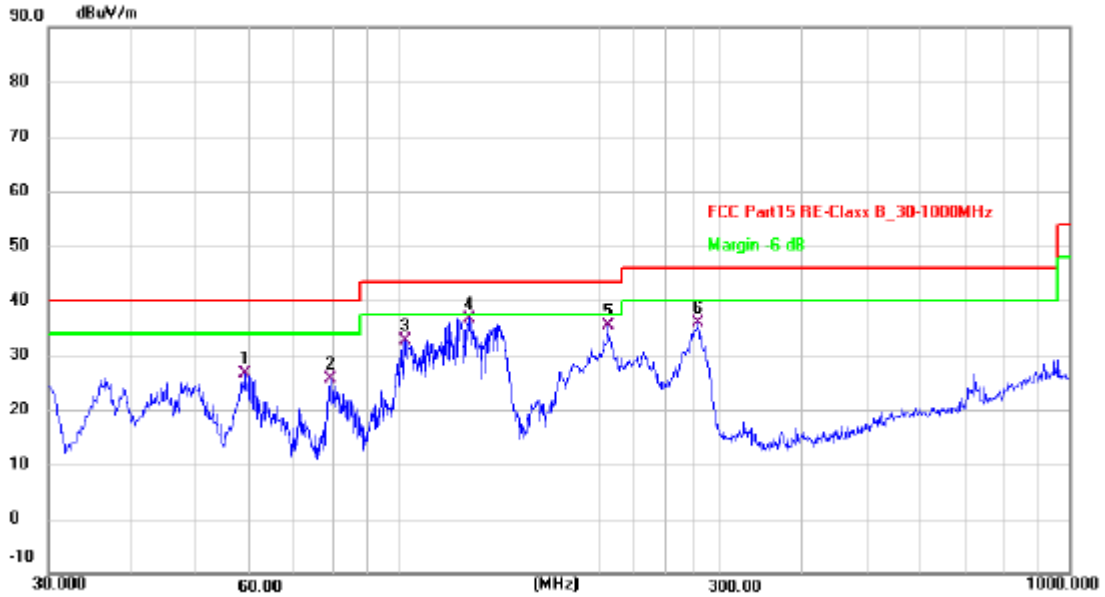

No.	Frequency (MHz)	Reading (dBuV)	Factor (dB/m)	Level (dBuV/m)	Limit (dBuV/m)	Margin (dB)	Detector
1	58.8185	41.87	-15.26	26.61	40.00	-13.39	QP
2	79.5209	44.10	-18.55	25.55	40.00	-14.45	QP
3	102.3597	50.01	-17.31	32.70	43.50	-10.80	QP
4 *	127.6645	51.49	-14.74	36.75	43.50	-6.75	QP
5	204.9551	51.65	-16.26	35.39	43.50	-8.11	QP
6	280.0237	49.82	-14.06	35.76	46.00	-10.24	QP

Note: Result=Reading+Factor  
Over Limit=Result-Limit

## 8. Photographs of test setup

RE

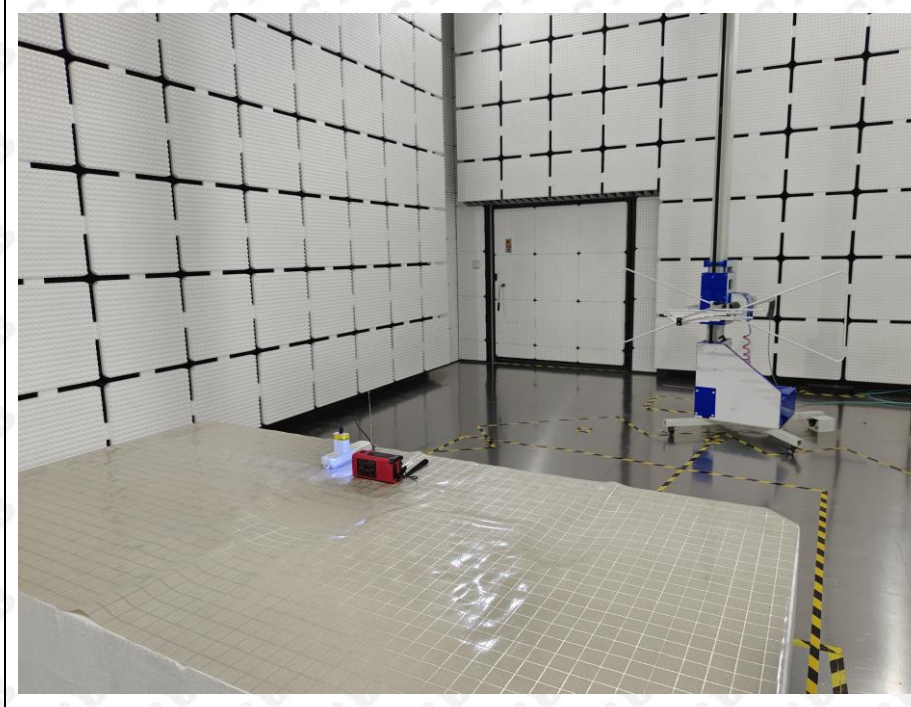

CE

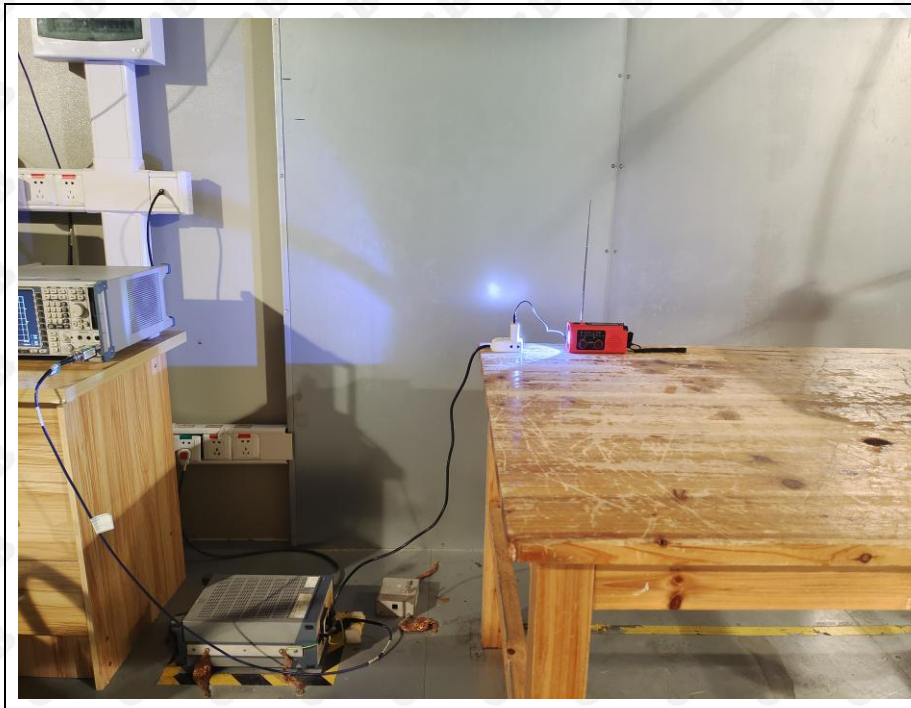

\*\*\*End of report\*\*\*