

承 認 書

客 戶:
CUSTOMER: 深圳市中利冠达科技有限公司

客 戶 料 號:
CUST P/N:

三盛创 料 號:
FINE P/N: **A4011-6.5UH 单线圈 unicoil 0.07*100P*12TS**

產 品 型 號:
DESC: **Φ44MMX5.0MMX0.8MM**

日 期:
DATE: **2021/04/27**

版 本:
Version: **A.0**

擬制 PREPARED BY	審核 CHECKED BY	批准 APPROVED BY	客戶承認 CUSTOMER APPROVE
林素玲	安帅印	安帅印	

SPECIFICATION

產品型號: DESC	Φ13.5x39.5-6.5uH-0.07x100P-20mm	版本 Rev: A.0	客戶 CUST: 客戶料号 CUST P/N:	
---------------	---------------------------------	----------------	----------------------------	--

一、尺寸 DIMENSION:(mm)

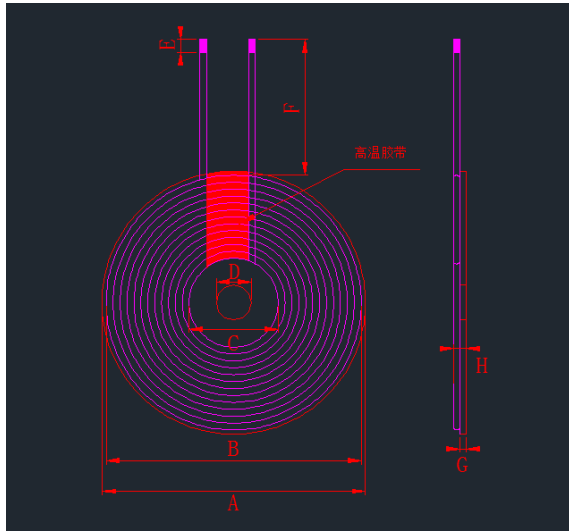

A	44.0±0.5
B	41.0±0.5
C	13.5±0.5
D	5±0.3
E	3±1
F	20±2
G	1±0.2
H	2.2±1

Attention:

1. Cross out wire;
2. Wrap 5mm(ref) width high-temperature adhesive paper 1-2Ts around the cable outlet position.
3. The coil is attached to the circular hard magnetic disc with groove, the magnetic disc size is 40±0.5mm, the inner hole is 5.3mm, and the thickness is 1.0±0.2mm.

二、原理图 SCHEMATIC DIAGRAM:

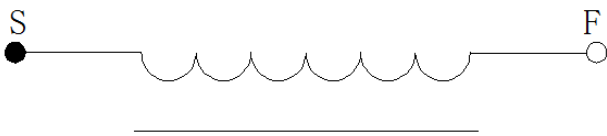

三、绕线参数 Winding Specification:

序号 NO.	端子 TERMINAL		线径 WIRE	圈数 Turns	绕线方向 Winding Direction
1	S	F	丝包线 0.07*100P silk-covered wire	12Ts	CCW

四、电气特性 ELECTRICAL CHARACTERISTICS:

温度 TEMPERATURE:25±10 °C, 湿度 RELATIVE HUMIDITY:65±20%

序号 NO.	项目 ITEM	端子 TERMINAL	标准 SPECIFICATION	测试条件 TEST FREQUENCY	测试仪器 TEST EQUIPMENTS
1	IND.	S-F	3.8 uH ±10% 单独线圈 Individual coil	100KHz/1.0V	LCZ METER 1062B
2	IND.	S-F	6.5uH ±10% 加磁片 Magnetized sheet	100KHz/1.0V	LCZ METER 1062B
3	DCR	S-F	≤50mΩ	100KHz/1.0V	LCZ METER 502B
4	Q	S-F	≤70	100KHz/1.0V	LCZ METER 502B

擬制/日期 PREPARED BY/DATE 林素玲 2021/04/27	審核/日期 CHECKED BY/DATE 安帅印 2021/04/27
--	---