



USER MANUAL

MODEL NO:P151 C



Notices: Read this user manual carefully before operating the lock and keep it for future use.

Table of Contents

Installation Instruction

Product Description	02
Product Dimensions	03
Preparing for Installation	04
Installation Instructions	05
Step 1. Check the dimensions	05
Step 2. Install the deadbolt and strike plate	06
Step 3. Install the Exterior Assembly	07
Step 4. Install the Mounting Plate	08
Step 5. Match Left/Right Hand Door and Interior Assembly Installation	09

User Guide

How to Use	13
How to Adjust Settings	15
1.How to Program User Access Code	16
2.How to Set Up the System	17
How to Connect to App	18
APP Operation Instruction	22
Family Management & Access Sharing	26
Trouble Shooting	29
Specifications	33
How to Reset The Device	34
After-Sales & Technical Support	35

Product Description

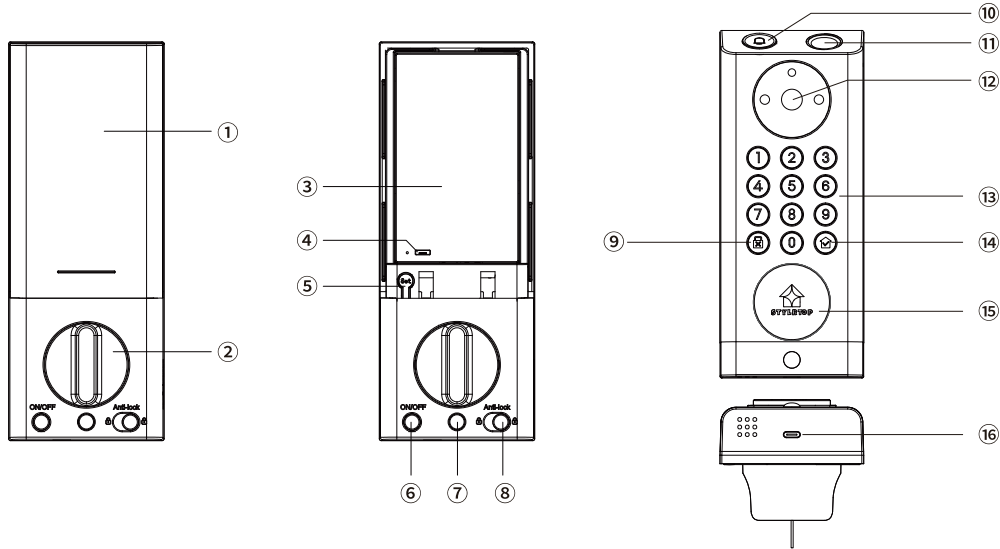

① Battery Cover	② Thumbturn	③ Battery	④ Battery Charging Port
⑤ Reset Button	⑥ On/Off Button	⑦ Rubber Plug Hole	⑧ Indoor Anti-lock Switch
⑨ Cancel/Return/Lock	⑩ Doorbell Button	⑪ Fingerprint Scanner	⑫ Camera
⑬ Keypad	⑭ Menu/Confirm/Enter	⑮ Mechanical Key Hole	⑯ Emergency USB Charging Port

Product Dimensions

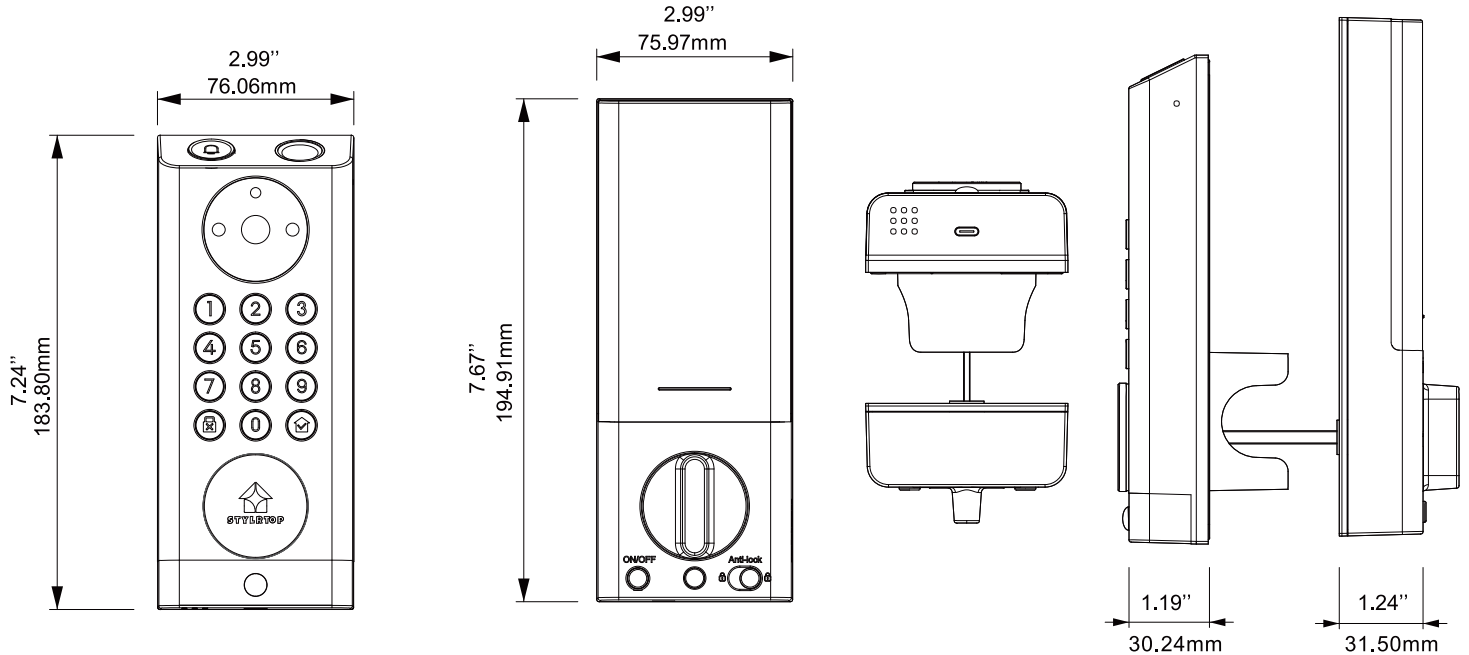

Preparing for Installation

PACKING LIST

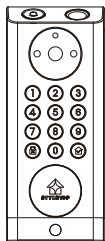

Exterior Assembly

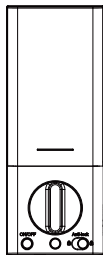

Interior Assembly

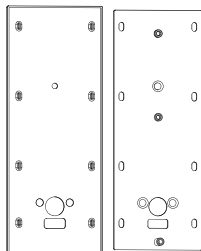

Mounting Plate



Lithium Battery

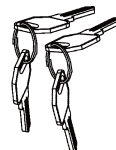

Keys



Double-sided Tape
Mounting Plate



Plug

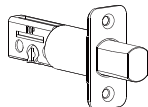

Deadbolt

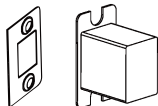

Strike Plate and Box



Screw A
Deadbolt/Strike



Screw B



Screw C



Screw D



Screw E



Screw F
Indoor Assembly

Installation Instructions

Step 1. Check the dimensions

- Check if your door has holes like the one below. Standard US doors are already compatible.
- If not, follow the template to drill holes on your door.

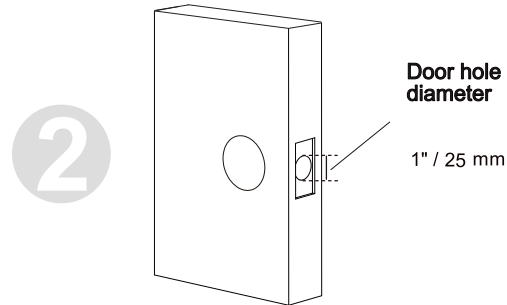
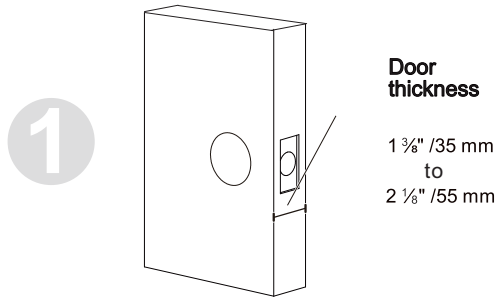

- Check your door to see if the deadbolt requires adjustment.

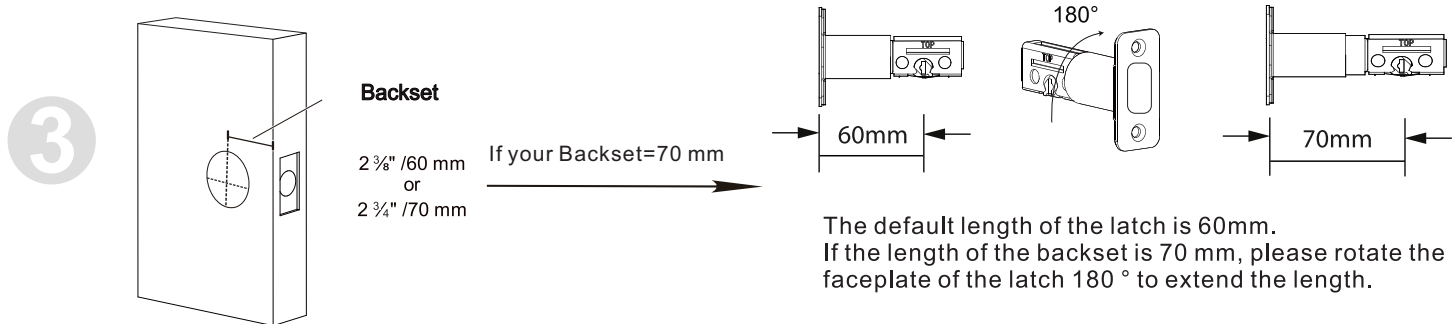

Installation Instructions

- Remove the spacer before installation if you have a 38 mm cross bore.

4

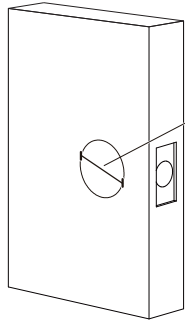

Cross bore diameter

2 1/8" /54mm
or
1 1/2" /38mm

If your Cross bore=38mm

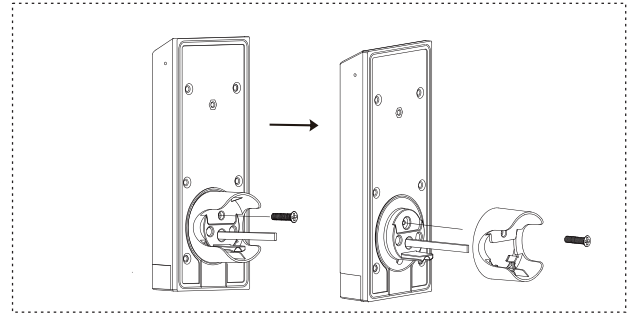

Step 2. Install the deadbolt and strike plate

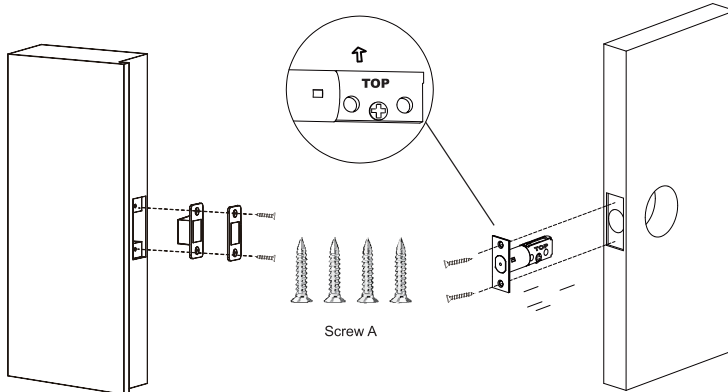

- Check if the deadbolt slotted hole centered in the Cross bore, If not, please back to the step 1 and adjust the length of the latch.
- Please note that the word "Top" faces upwards.

Installation Instructions

Step 3. Install the Exterior Assembly

Important :Please note before installing exterior assembly

- Remove the spacer before installation if you have a 38 mm cross bore (reference step 1);
- Please ensure that the latch is in the **unlocked** state before installation- the pin is **inside** the set;
- Please ensure that the tailpiece is inserted **vertically** into the slot of deadbolt.

- 1.Run the wires through under the latch;
2. Insert the tailpiece vertically into the slot of the latch;
3. Fix the external assembly with the double side tape3.

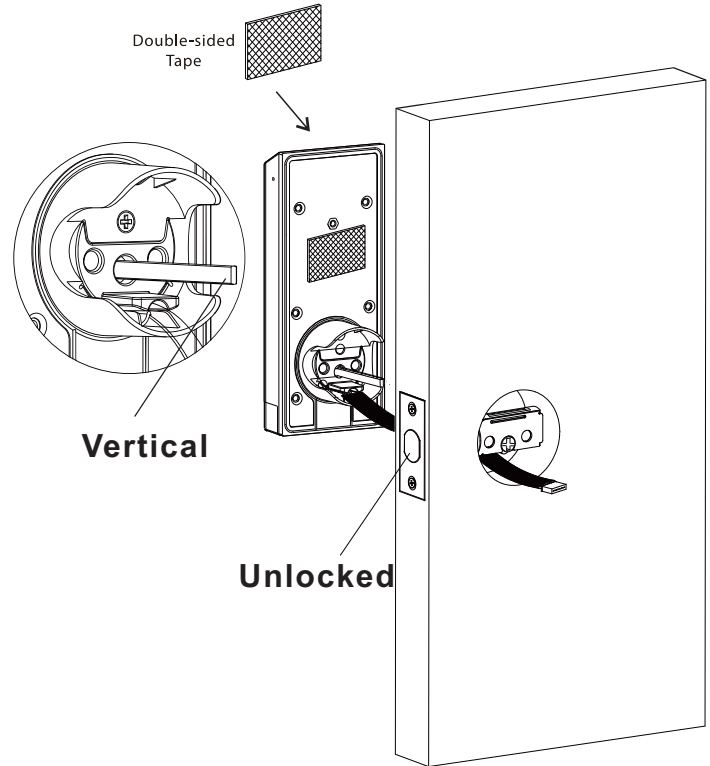

Installation Instructions

Step 4. Install the Mounting Plate

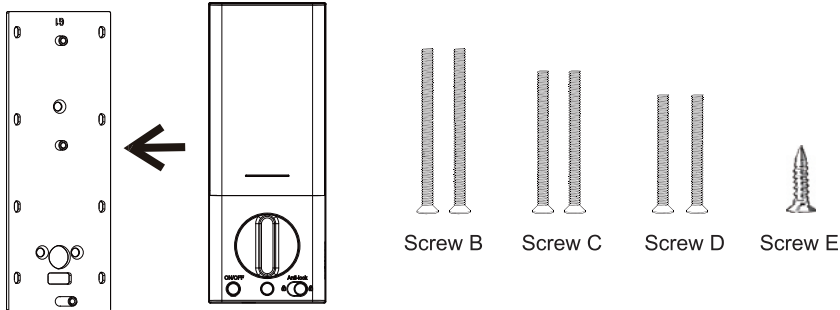

Mounting Plate

1. Detach the mounting plate from the interior assembly.
2. Run the wires through the mounting plate.
3. Secure the mounting plate with screws.
4. The function of screw E is to secure the lock firmly.

Important: Please select Screw B, Screw C, or Screw D based on the thickness of the door (35mm-55mm)

Door thickness compatibility for Screw B: 50~55mm

Door thickness compatibility for Screw C: 40~50mm

Door thickness compatibility for Screw D: 35~40mm

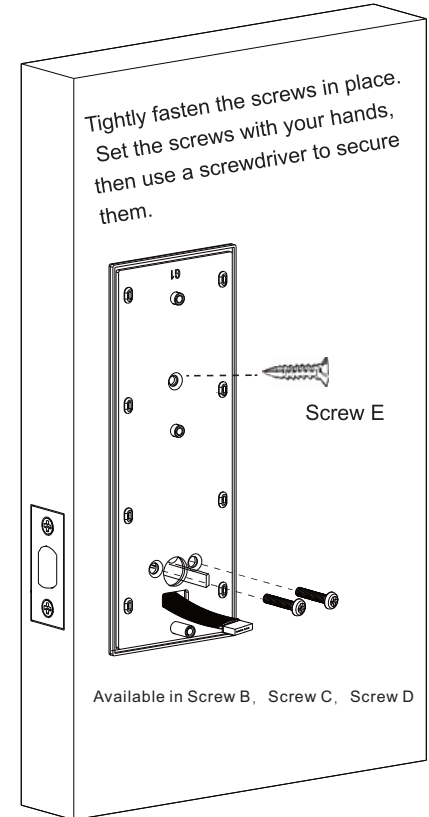

Installation Instructions

Step 5. Match Left/Right Hand Door and Interior Assembly Installation

1. Distinguish between left hand door and right hand door

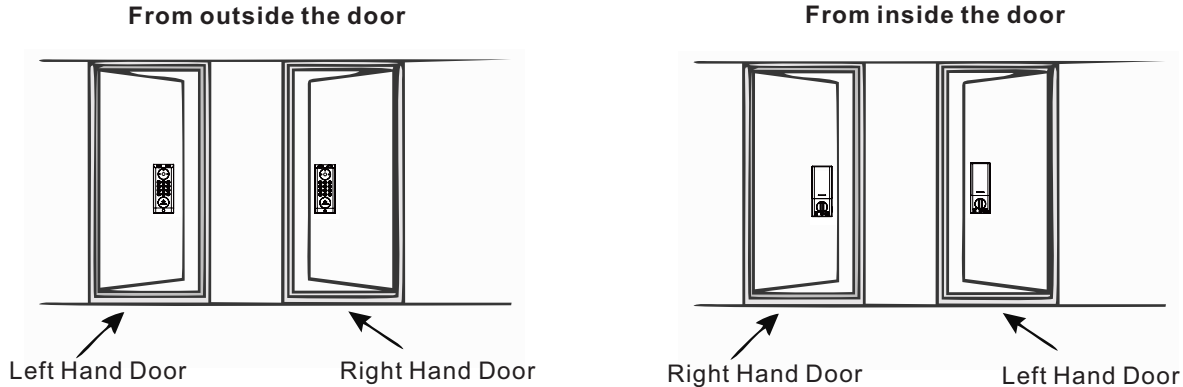

Important: This step is required and crucial for the lock after installation!

2. Adjust the(L/R)switch

Adjust the(L/R)switch on the circuit board of internal assembly to the corresponding position, for the right hand door turn to "R", and for the left hand door turn to "L".

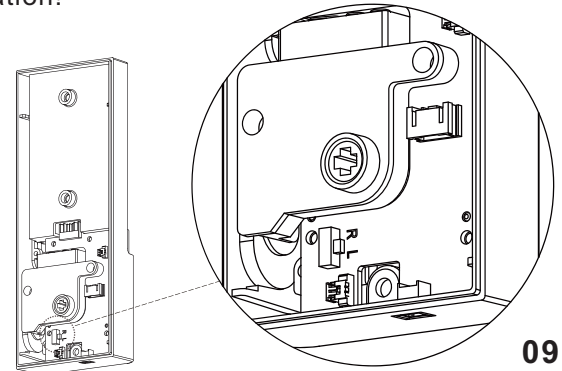

Installation Instructions

3. Install the interior assembly of the left hand door

- 3.1 Make sure the "L/R" switch is turned to the "**L**" position in the above steps;
- 3.2 Connect the wires to the interior assembly;
- 3.3 **Turn the thumbturn to the vertical position and insert the tailpiece;**
- 3.4 Secure the interior assembly with F Screws;
- 3.5 Plug the rubber plug into the screw hole of the interior assembly.

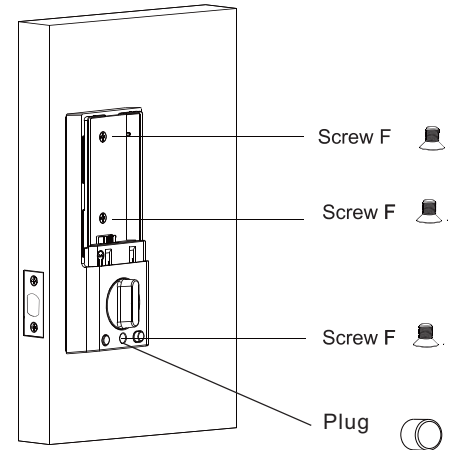
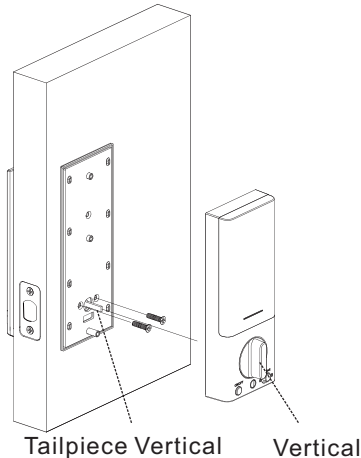
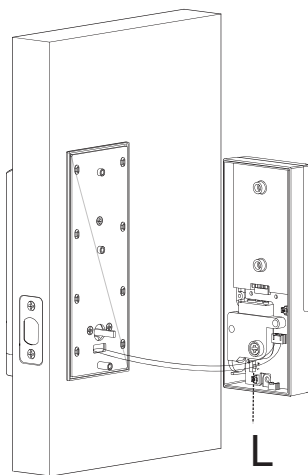

Note: Whether it is the right hand door or the left hand door, make sure the tailpiece is vertical.

Installation Instructions

4. Install the interior assembly of the right hand door

- 4.1 Make sure the "L/R" switch is turned to the **"R"** position in the above steps;
- 4.2 Connect the wires to the interior assembly;
- 4.3 **Turn the thumbturn to the horizontal position and insert the tailpiece;**
- 4.4 Secure the interior assembly with F Screws;
- 4.5 Plug the rubber plug into the screw hole of the interior assembly

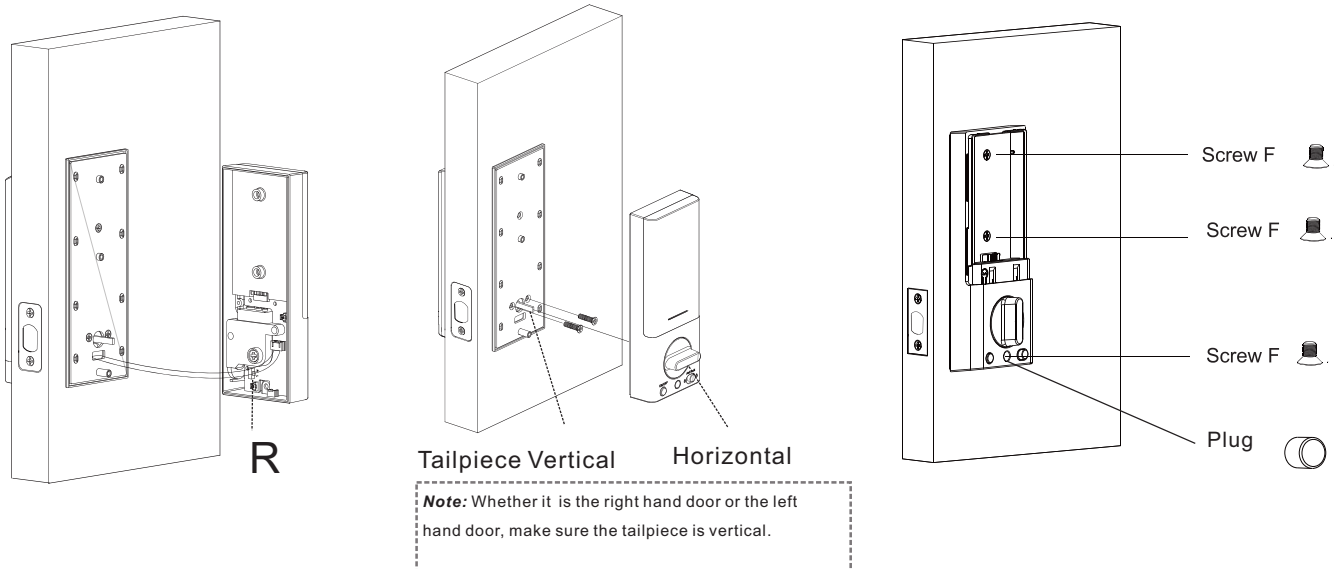

Installation Instructions

Step 6. Mechanical Testing

1. Rotate the thumbturn and check if the Deadbolt works properly.
2. Insert the Key and rotate it to check if the Deadbolt works properly.

Note: If the Deadbolt is actuated not smooth enough with the thumbturn or the key, please read the previous steps carefully and troubleshoot.

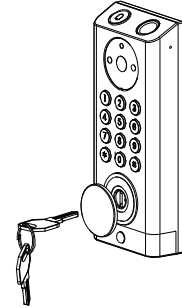

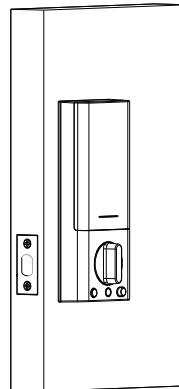
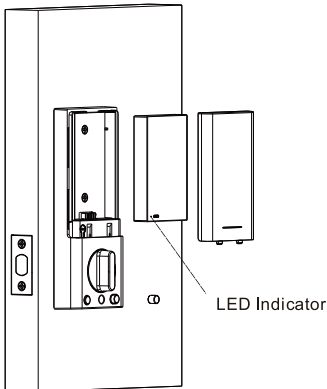

Step 7. Load the battery

Fully charge the battery before first use. It might take about 6 hours. The red LED indicator means insufficient battery, while the green light indicates the battery is fully charged.



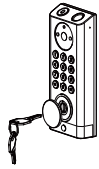

How to Use

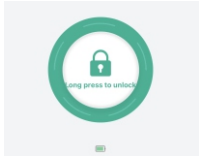

1、Unlock the door from outside

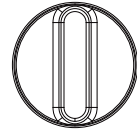
<p>①</p>  <p>Unlock via mechanical key</p>	<p>②</p>  <p>Unlock via passcode or fingerprint</p>	<p>③</p>  <p>Remote Unlock via APP</p>
---	--	---



2、Unlock the door from inside

<p>①</p>  <p>Turn the thumbturn to the unlock position.</p>	<p>②</p>  <p>Press ON/OFF Button</p>
---	---

3、Lock the door from outside

<p>①</p>  <p>Press Lock Button</p>	<p>②</p> <p>Auto-Lock Mode</p> <p>In auto-lock mode, the bolt will extend out automatically in seconds after unlocking</p> <p>Customizable for</p> <ul style="list-style-type: none">6 seconds15 seconds30 seconds	<p>③</p>  <p>Remote Lock via APP</p>
---	--	---

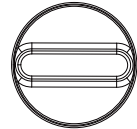
4、Lock the door from inside

<p>①</p>  <p>Turn the thumbturn to the lock position.</p>	<p>②</p>  <p>Press ON/OFF Button</p>
--	---

5、Works with Amazon Alexa



The Smart Lock can work with Amazon Alexa app. With Amazon Alexa devices at home, you can lock/unlock the door via voice commands.

Note:

- Make sure you've downloaded the Amazon Alexa.
- Make sure your Amazon Alexa devices are connected to the network.

6、Anti-Lock

Anti-Lock



When the Anti-Lock switch is turned on, only administrators will be allowed to access, and regular users will be denied.

How to Use

7.Remote intercom and unlocking

① Press Door Bell

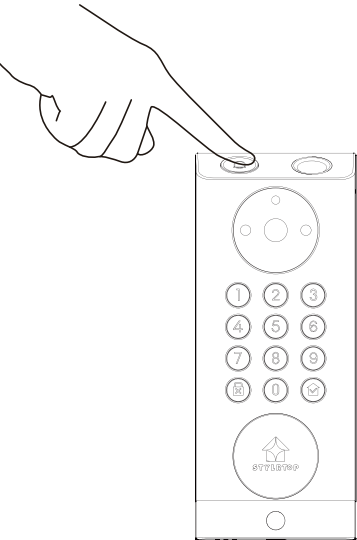

② Doorbell Notification

Offline Notification

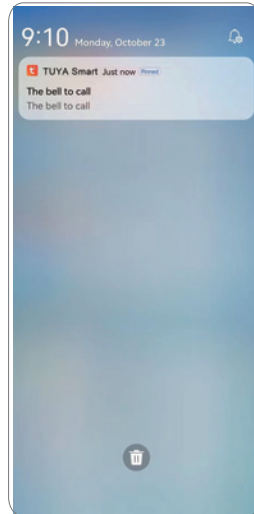

Online Notification



③ Intercom and Unlocking Interface



1. When the app is offline, you will receive a message notification. Click on the notification and then select "Video surveillance" to enter intercom mode or unlock.

2. When the app is online, a 'video call' will pop up. Click 'answer' to enter intercom mode or unlock.

How to Adjust Settings

Before issuing any command, the keyboard must be awakened. Press any button (except for ) to wake up the keyboard. The keyboard LED indicator lights up after awakening.

Function Button Description

 <ul style="list-style-type: none">-Exit-Return to the previous level of settings-Lock	 <ul style="list-style-type: none">-Enter Settings-Confirm
---	--

User Type

Type	Capacity	Description
Administrators	5	<ul style="list-style-type: none">• Sequence ID 1-5• Unlock• Management
Regular User	95	<ul style="list-style-type: none">• Sequence ID 6-100,• Unlock,(Invalid when the Anti-lock is engaged)
Total	100	<ul style="list-style-type: none">• Fingerprint Capacity:50• Passcode Capacity:50

How to Adjust Settings

1. How to Program User Access Code



The default Administrator code is 123456. It's required that you change it to a code of your own before programming.

After adding the first administrator password or fingerprint, the default code will be invalid.

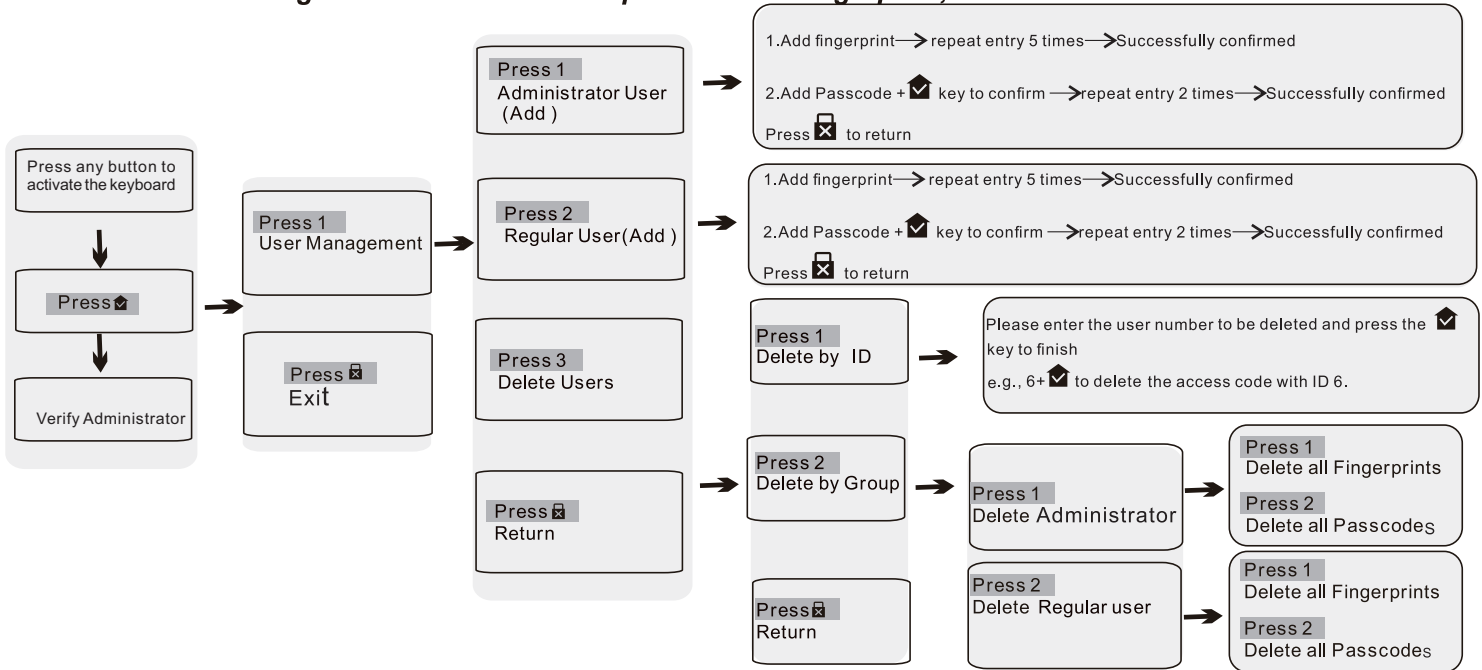

How to Adjust Settings

2. How to Set Up The System

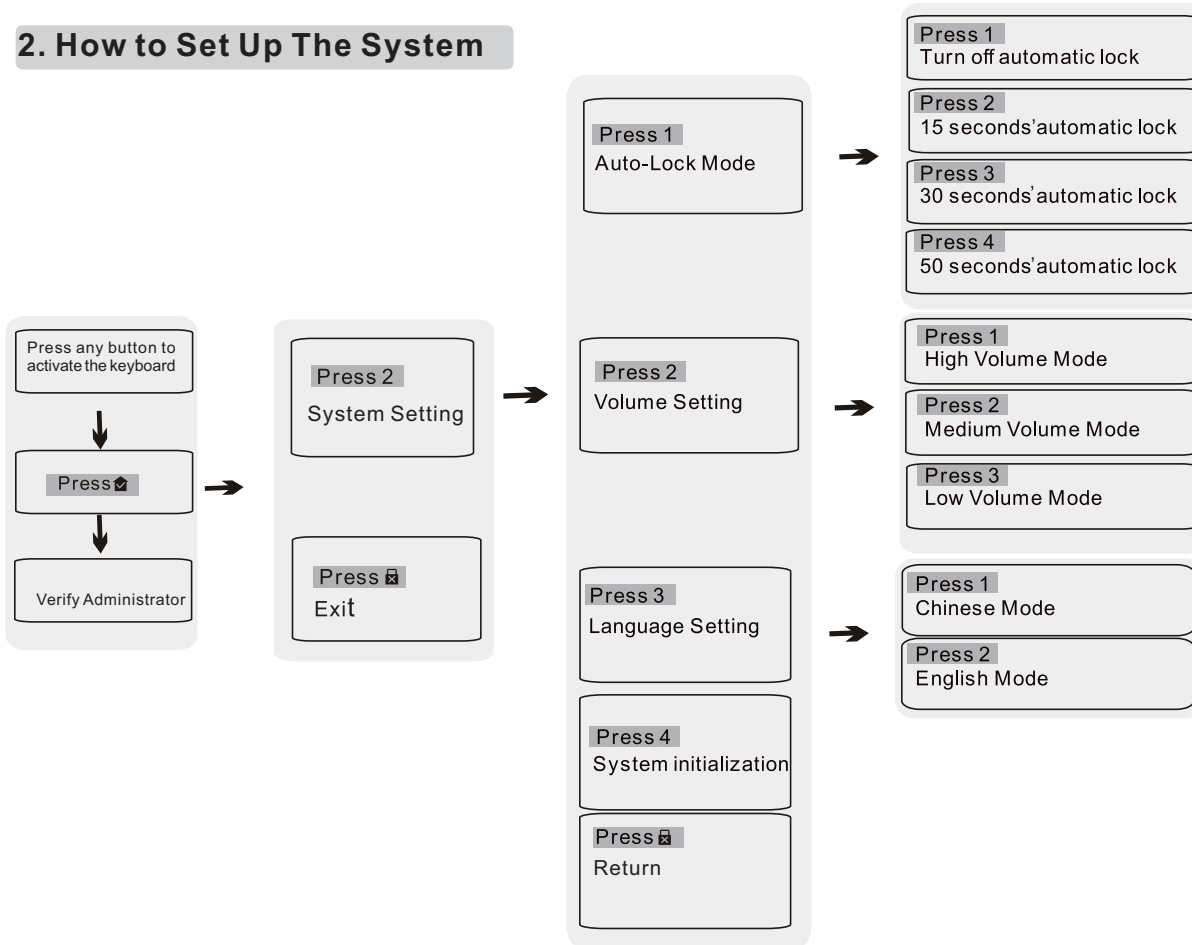

How to Connect to APP

Step 1 Preparations before connecting to the APP

1. This device only supports **2.4GHZ** Wi-Fi network. If your network is a 5GHZ or mixed-band network, please change to a 2.4G network. If your Wi-Fi signal name is not marked with a frequency band, please enter the router background to check.
2. **Connect your phone to the 2.4 G Wi-Fi network first.**
3. **Turn on your phone's Bluetooth**

IMPORTANT

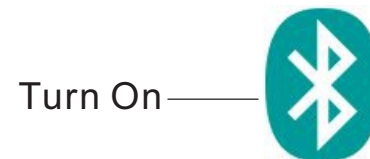

Step 2 Download the TUYA Smart APP

Download the **Tuya Smart APP** from App Store(iOS devices),or Google Play(Android devices)or Scan the following QR code and download it through the browser. then sign up for an account.



How to Connect to APP

Step 3 Set the lock to Wi-Fi Pairing Mode

Follow the process below to set the lock to Wifi pairing mode

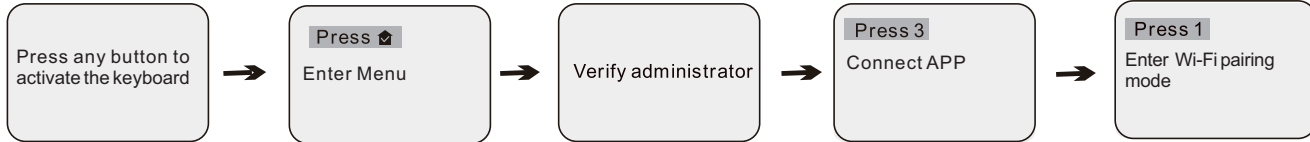

The  button LED flashing means entering pairing mode successfully.

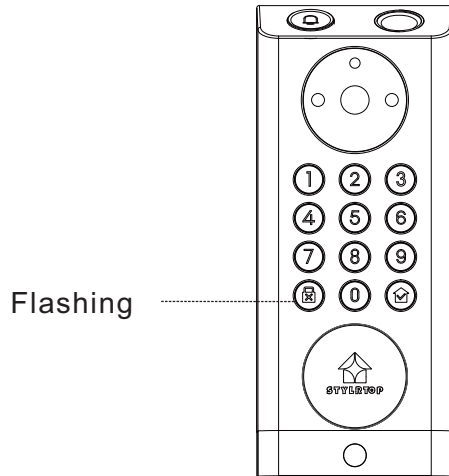

How to Connect to APP

Step 4 Connect to APP and connect to Wi-Fi

- Please make sure that your phone is connected to the 2.4G Wi-Fi network
- Please make sure that your phone's Bluetooth is turned on

Log in to the TUYA Smart app and click on “+” in the upper right corner to add device

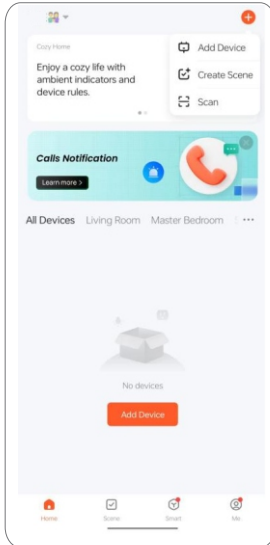

Waiting for device search



Once the device is discovered, click Add



How to Connect to APP

Choose the same 2.4G WiFi network as your phone and enter your password

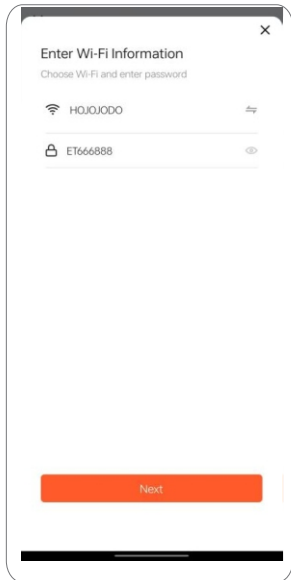

Waiting for device to be added

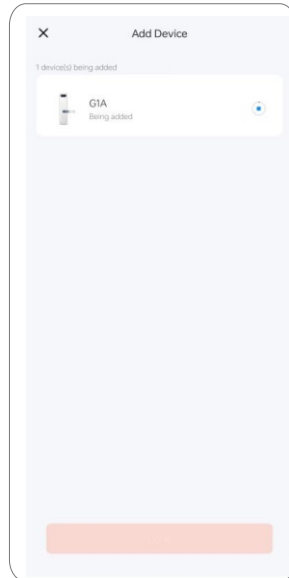

Device added successfully

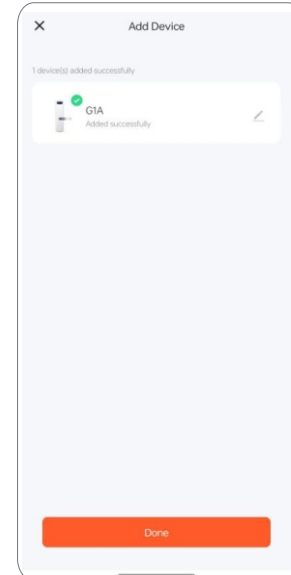

APP Operation Instruction

1 . APP Operation Instruction

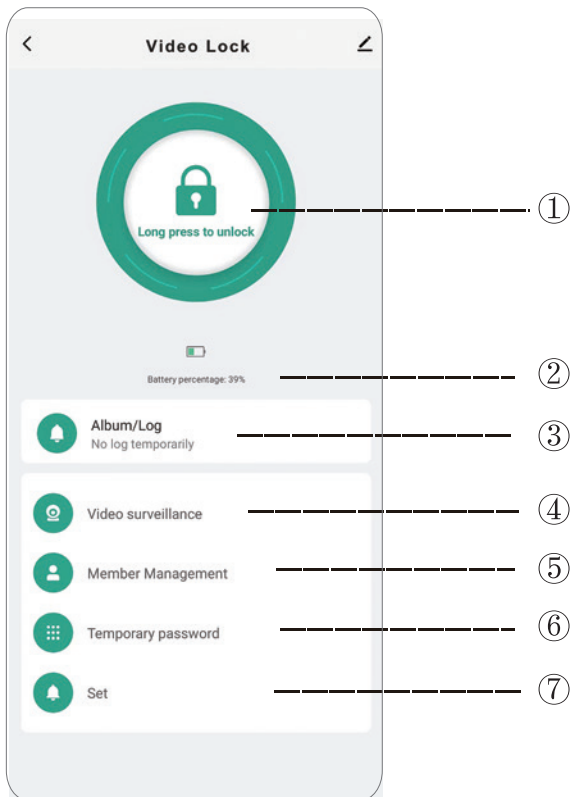

① Remote lock/unlock button

Long press to unlock or lock.

② Battery Remaining Display

Please note that if the battery level is below 10%, you cannot actively view the Video Surveillance

③ Album and log function

Album Function

- Record and capture photos of remote door opening requests
- Record and capture when someone is detected (can be set to capture a 10-second video)
- View actively recorded videos
 - You can access the storage service for the past 3 days for free, with up to 30 video events (Automatically overwrite)
 - Click  on the bottom right corner of the video to download it

Log Function

- View alarm records and door opening records

APP Operation Instruction

④ Video surveillance

Proactively recording video up to 3 minutes

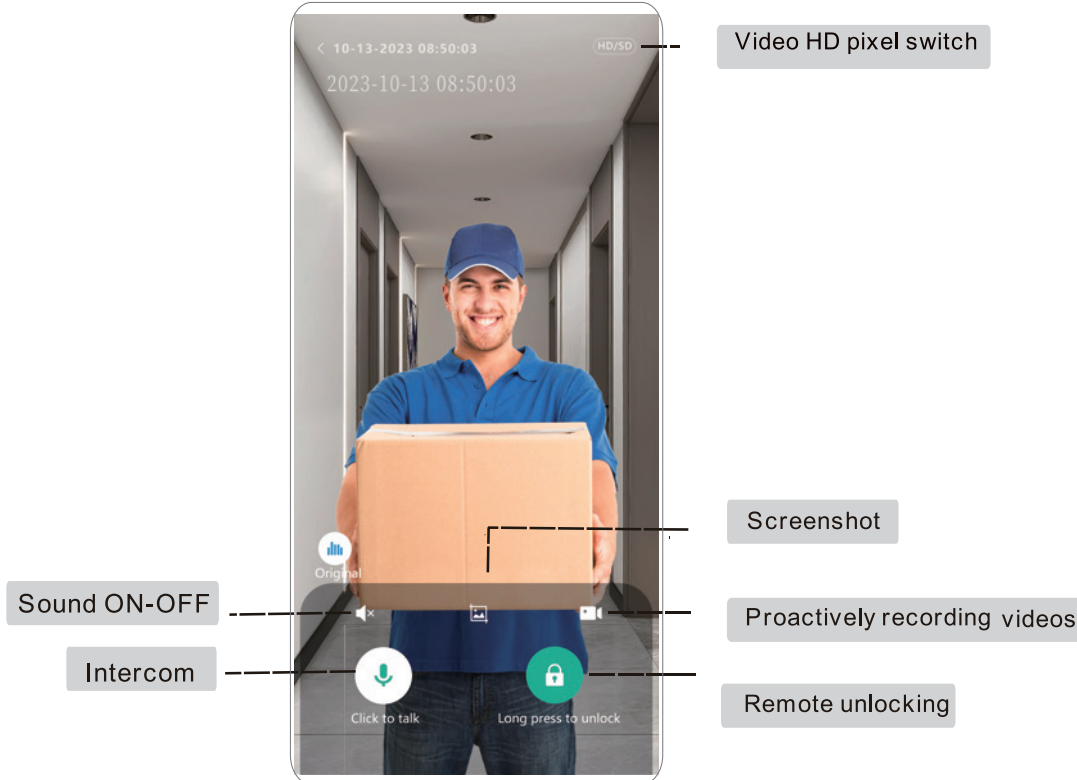

Video HD pixel switch

Screenshot

Proactively recording videos

Remote unlocking

Sound ON-OFF

Intercom

APP Operation Instruction

⑤ Member Management

- Click “+” on the top right corner to add a new user name (Account is not mandatory)
- In the door opening log record, click "Bind user" to link the access code with the added user

Please note that this version protects user data absolutely securely. The APP and the cloud cannot read or write passwords, so passwords cannot be added or deleted through the APP.

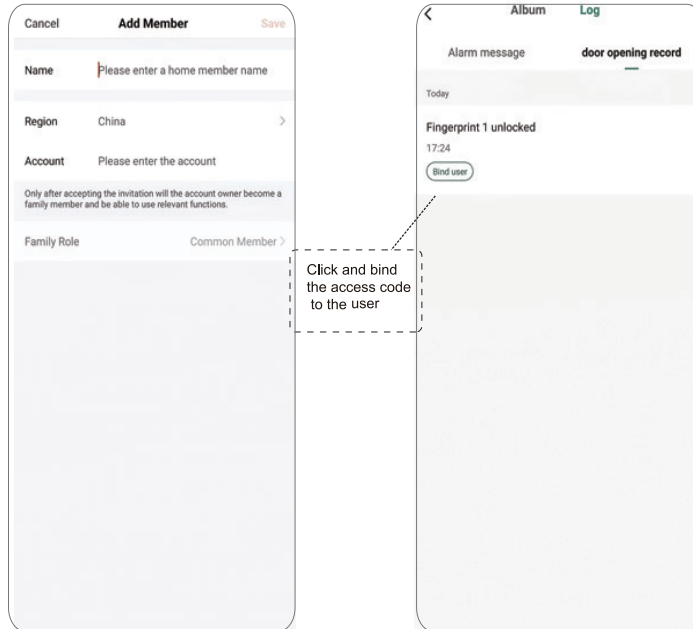

⑥ Temporary Passcode

Generate a temporary password that is valid for five minutes

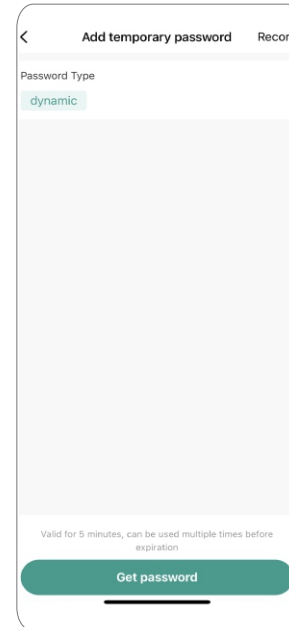

APP Operation Instruction

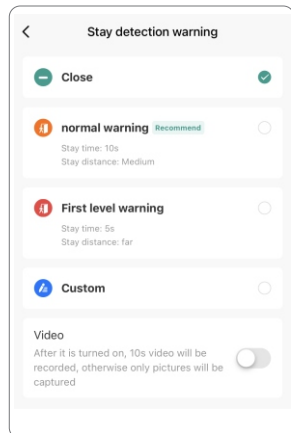
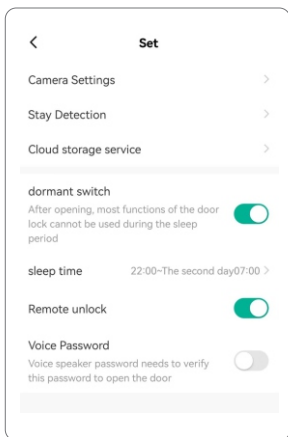

⑦ Set

1.Camera Settings

It is recommended to choose between one-way (hold the talk button to speak) or two-way (click to communicate freely) based on your needs.

2.Stay Detection

- Please select this function as needed, as it may increase the speed of power consumption.
- By default, capturing a thumbnail is enabled. Turning on the Video switch will change it to recording a 10-second video

Note:

This function takes 1-2 seconds to connect network, Only the one who stay for more than 2 seconds can be recorded, quick movements may not be captured.



3.Dormant Switch

- After the Dormant switch is turned on, While device is sleeping, the APP will be absolutely offline and you will not be able to operate and set the app, including viewing surveillance videos. **Please be cautious when turning it on.**
- Closing method
 - a. When dormant time ends, the network connection is automatically activated.
 - b. Press the doorbell or enter a password to activate the network connection, and then turn off the Dormant Switch.
- The doorbell and stay detection are not affected by this mode.



4.Remote Unlock

Turn off to disable the remote unlock.

5.Voice Password

Voice speaker password needs to verify this password to open the door.

Family Management & Access Sharing

1 . Create A Home

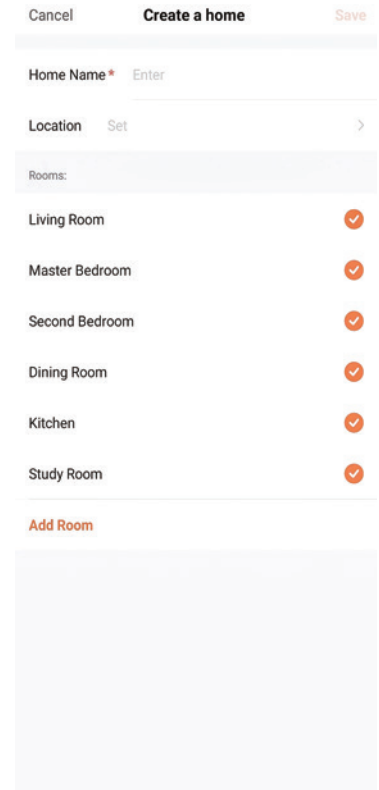
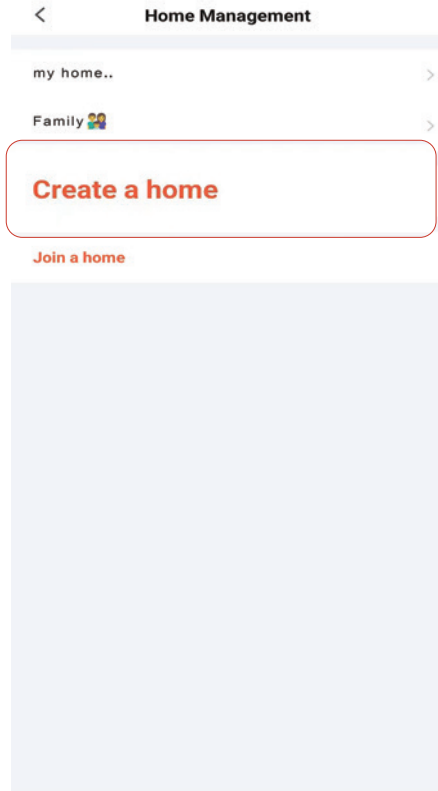
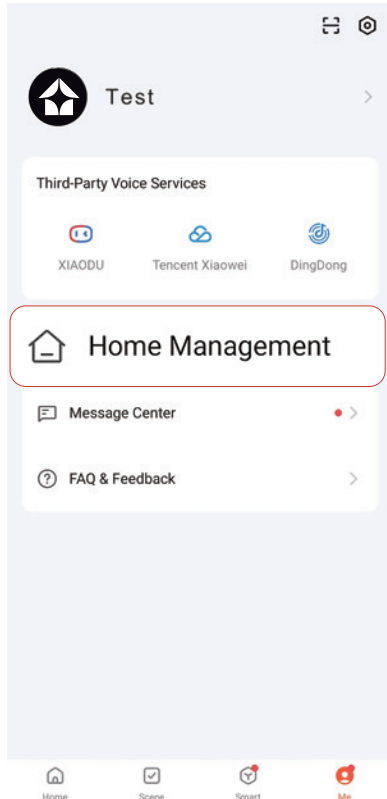

Family Management & Access Sharing

2 . Share APP access with other family members

① Add member's TUYA account by the family creator to join the Home

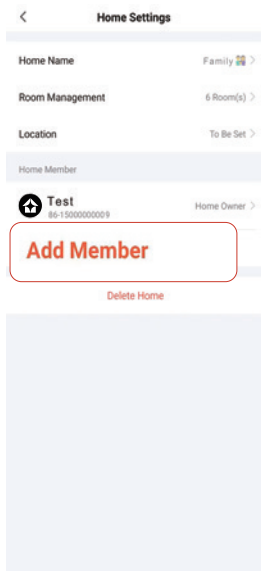

Creator invites

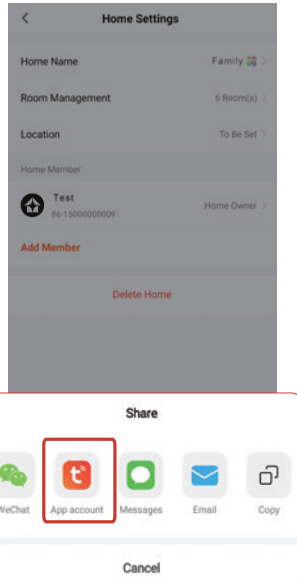

Add member's TUYA account

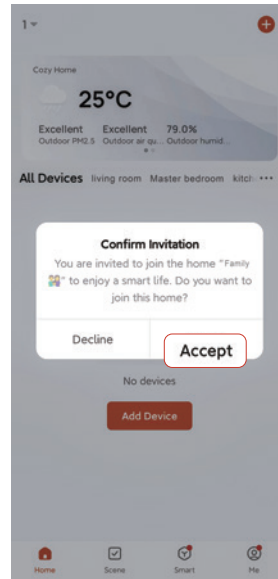

Member accepts

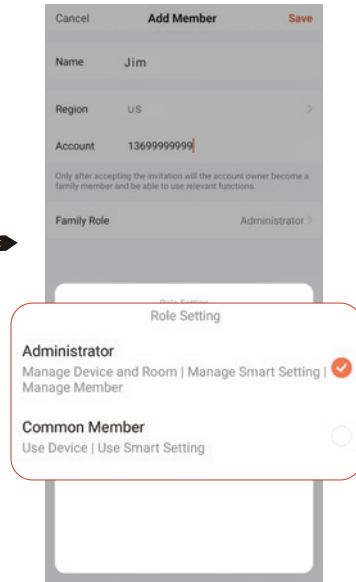

Role setting

Family Management & Access Sharing

② Members actively joining the family

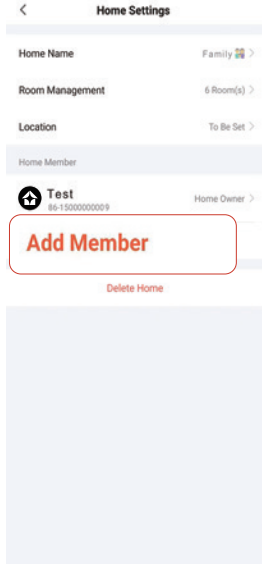

Creator invites

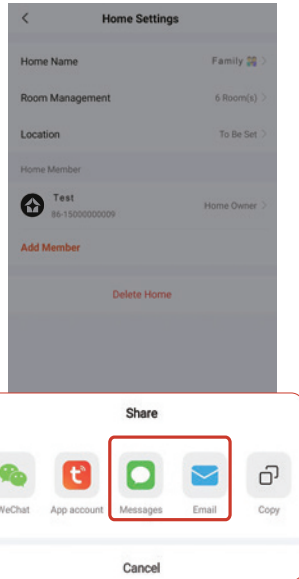

Share invitation code via message or other APP

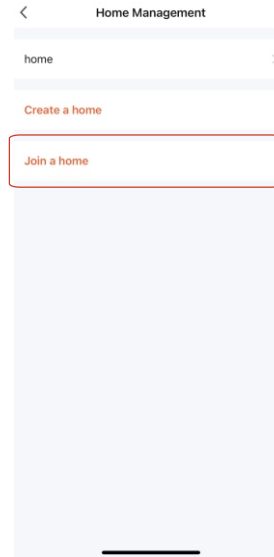

Join a home

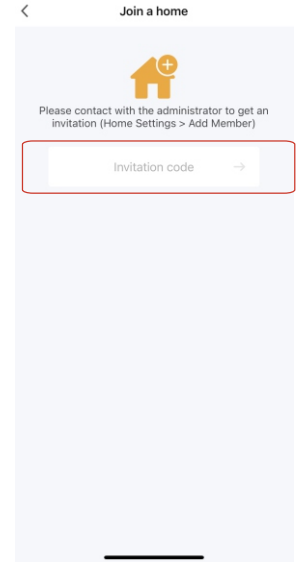

Fill in the invitation code

Trouble Shooting

1.Installation

Questions	Answers
Keypad not responding.	<ul style="list-style-type: none">• Make sure the batteries are installed properly.• Make sure the wires is well-connected to the port, and has not been damaged during installation.
Are there any extra screws?	<ul style="list-style-type: none">• When installing the mounting plate, appropriate screws need to be selected based on the thickness of the door.Three sizes of screws are provided,but only one size needs to be selected.Please refer to page 7.
Tell it to lock, it unlocks, tell it to unlock it locks.	<ul style="list-style-type: none">• The left-hand door and the right-hand door were confused during installation. Please refer to pages 9-11.
The latch pin always bounces back and cannot be locked, or the movement is not smooth.	<ul style="list-style-type: none">• Check if the Strike box is installed correctly. If the Pin encounters obstacles, it will retract to protect itself.• Check if the door dimensions are compatible with this device. Please refer to pages 5-6.• Check if the left-hand door or right-hand door installation is confused. Please refer to pages 9-11.

Trouble Shooting

2.Operation

Questions	Answers
Can't connect to Wi-Fi	<ul style="list-style-type: none">• This device only supports 2.4 GHz network and does not support 5G network and mixed-band network.• When connecting Wi-Fi to the device , Please make sure that the lock is in pairing mode (please refer to page 19). Please make sure that your phone is connected to the 2.4G Wi-Fi network. Please make sure that your phone's Bluetooth is turned on. When you select the Wi-Fi to the device, you must choose the same 2.4G network Wi-Fi as your phone. (After the lock's Wi-Fi connection is successful, the access network of your phone does not restrict 5G or 2.4G)• How to test whether the Wifi network meets the requirements: Prepare a phone that provides a hotspot network as a Wifi signal, and connect the lock to the hotspot Wi-Fi according to the above requirements. If the network connection is successful and works properly, please log in to the router's background to check the Wi-Fi frequency band and signal stability it provides.
The device is stay offline and cannot reconnect to the network	<ul style="list-style-type: none">• Please check if the lock has entered dormant mode. While device is sleeping, the APP will be absolutely offline.(please refer to page 25)• When the battery power is lower than 10%, the lock will automatically enter low-power mode and disconnect from the network to ensure basic functions such as locking and unlocking. The network connection triggered by the doorbell is not affected by low battery.

Trouble Shooting

Questions	Answers
Cannot view the Video Surveillance.	<ul style="list-style-type: none">• Battery level is below 10%, please charge it.• The device is offline. Please click on the signal button (unlock button) on the homepage to reconnect the network
Why do devices often stay offline when entering the app?	<ul style="list-style-type: none">• Devices only automatically connect to the network when needed, thus reducing power consumption• Click on the signal icon on the homepage to actively connect to the network
After installation for the door lock there is no response or shows unusual behavior.	<ul style="list-style-type: none">• Please check battery has enough power. It is recommended that fully charge before the first use.
Any fingerprint can unlock the lock?	<ul style="list-style-type: none">• The lock was reset, please make sure the password was programmed successfully after installation.
What should I do if the battery is completely dead?	<ul style="list-style-type: none">• There is a USB port on the head of the exterior handle. You can charge the lock with a power bank to unlock with a programmed fingerprint.
Fingerprint recognition failed	<ul style="list-style-type: none">• When programming the fingerprint, please move the fingerprint across a larger area• Fingers are too dry, wet, oily or dirty.• There is direct sunlight on the sensor.

Trouble Shooting

Questions	Answers
A thumbnail or video feedback from Stay Detection but shows no one staying	<ul style="list-style-type: none">• The stay detection function takes 1-2 seconds to activate, so the device cannot capture the fast passing objects.• All movements will activate this function. Please eliminate unnecessary interference or turn off this function to avoid misjudgment and increased power loss.
Can not to connect to Alexa	<ul style="list-style-type: none">• Make sure you've downloaded the Amazon Alexa app on your phone• Make sure your Amazon Alexa devices are connected to the network.
I forgot my Administrator Codes.	<ul style="list-style-type: none">• Perform a reset , Once the reset is complete, all codes will be erased and the Administrator code will return to the default code 123456.
When someone rings the doorbell, there is no APP notification, or there is no volume or the volume is too low.	<ul style="list-style-type: none">• This is determined by your phone settings. Please refer to the notification settings of your phone model to open and set the relevant permissions.

Specification

1.Power Supply:	7.4V lithium battery 5000mAh
2.Video:	1080p HD Video, Night Vision
3.Emergency power:	5V
4.Fingerprint Capacity:	Fingerprints 50 MAX, Passcodes 50 MAX
5.Fingerprint Pixels:	508dpi
6.Identification Speed:	0.25sec
7.False Positive Rate:	<0.0001%
8.Rejection Rate:	<0.1%
9.Working Temperature:	-15°C-50°C (5°F - 122°F)
10.Working Humidity:	40%~85%(no condensation)
11.Unlock Record Capacity:	100,Automatic overwrite
12.Static Power:	<350uA
13.Dynamic Power:	<400mA
14.Material:	Aluminum Alloy
15.Passcode length	Supports 6 -10 digits
16.Emergency power interface:	USB C
17.Scramble passcodes:	Support scramble passcode (add random digits before or after the real passcode).

3578

123456

65987

Random digits no length limit

Real Passcode

Random Digits

How to Reset The Device

How to reset your device

1. Software initialization

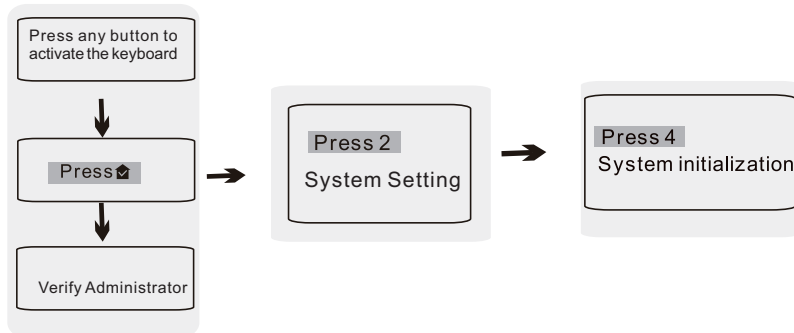

2. Hardware initialization

- Remove the battery cover
- Remove the battery
- Press and hold the set button below the battery and do not release
- Reinstall the battery
- Until you hear a beep, release the set button
- Voice prompt reset successful

If there is no successful voice prompt, please try again

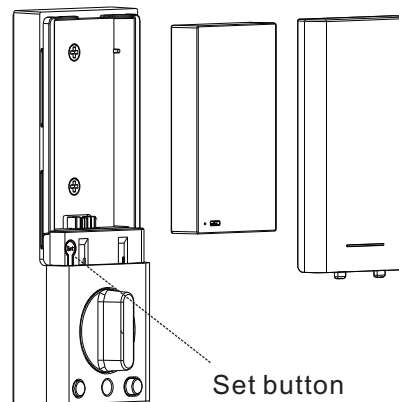

After-Sales & Technical Support

If the lock appears to be damaged or does not operate properly, please contact our customer service for further assistance.

After-Sales & Technical Support:



North America

Chituo@outlook.com

Support_US@stylrtp.com



Global

Support@stylrtp.com

For Amazon orders, please contact :

Chituo@outlook.com

we will get back to you as soon as possible.

Company Website :

<http://www.stylrtp.com>

Stylrtp Official YouTube Channel

Welcome to Stylrtp's official YouTube channel to watch the installation & setting video for Camera Lock P151 C



<https://www.youtube.com/@stylrtp>

FCC Statement

This equipment has been tested and found to comply with the limits for a Class B digital device, pursuant to part 15 of the FCC Rules. These limits are designed to provide reasonable protection against harmful interference in a residential installation. This equipment generates, uses and can radiate radio frequency energy and, if not installed and used in accordance with the instructions, may cause harmful interference to radio communications. However, there is no guarantee that interference will not occur in a particular installation. If this equipment does cause harmful interference to radio or television reception, which can be determined by turning the equipment off and on, the user is encouraged to try to correct the interference by one or more of the following measures:

- Reorient or relocate the receiving antenna.
- Increase the separation between the equipment and receiver.
- Connect the equipment into an outlet on a circuit different from that to which the receiver is connected.
- Consult the dealer or an experienced radio/TV technician for help.

Caution: Any changes or modifications to this device not explicitly approved by manufacturer could void your authority to operate this equipment.

This device complies with part 15 of the FCC Rules. Operation is subject to the following two conditions: (1) This device may not cause harmful interference, and (2) this device must accept any interference received, including interference that may cause undesired operation.

RF Exposure Information

This equipment complies with FCC radiation exposure limits set forth for an uncontrolled environment. This equipment should be installed and operated with minimum distance 20cm between the radiator and your body.



<http://www.stylrtop.com>

<https://www.youtube.com/@stylrtop>