

深圳旭航通讯科技有限公司

Shenzhen Xuhang Communication
Technology Co., Ltd

规格承认书

客户 CUSTOMER	德池
客户料号 CUSTOMER NO.	
供方品名 PART NAME	WIFI 天线
规格名称 SUPPLIER NO.	XH240049 (L=60mm)

客户确认 CUSTOMER APPROVED BY		
检验 APPROVAL	审核 CHIEF	批准 SUPERVISOR

设计 DESIGN	审核 CHECK	批准 APPROVAL
Luo	Robert	SHANG

April 13, 2024

电性测试报告

TEST REPORTS

频率 Frequency	WIFI(2400~2500MHz;5150~5850MHz)
阻抗 Impedance	50 Ohm Nominal
驻波比 V.S.W.R	≤2.0
回波损耗 Return Loss	-10dB Max
辐射 Radiation	Omni-directional
增益 Gain(Peak)	2.03dBi
极化方式 Polarization	Linear,Vertical
功率 Admitted Power	1W
连接器 Connector	I-PEX 3
Physical Properties	
天线材质 Antenna Material	FPC
线材类型 Cable Type	O.D.0.81mm
工作温度 Operating Temp.	-10-+60℃
存储温度 Storage Temp.	-10-+70℃
线材颜色 Cable Color	Black

匹配电路

Matching Circuits

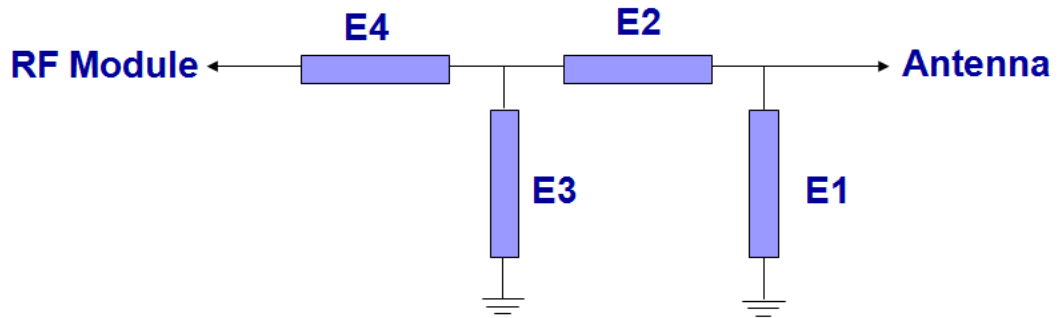

匹配电路

Element	Value	Vender
E1(0402)		
E2(0402)	0Ω	
E3(0402)		
E4(0402)	0Ω	

原匹配电路无修改

The original matching circuit has not been modified

工程图 DRAWING

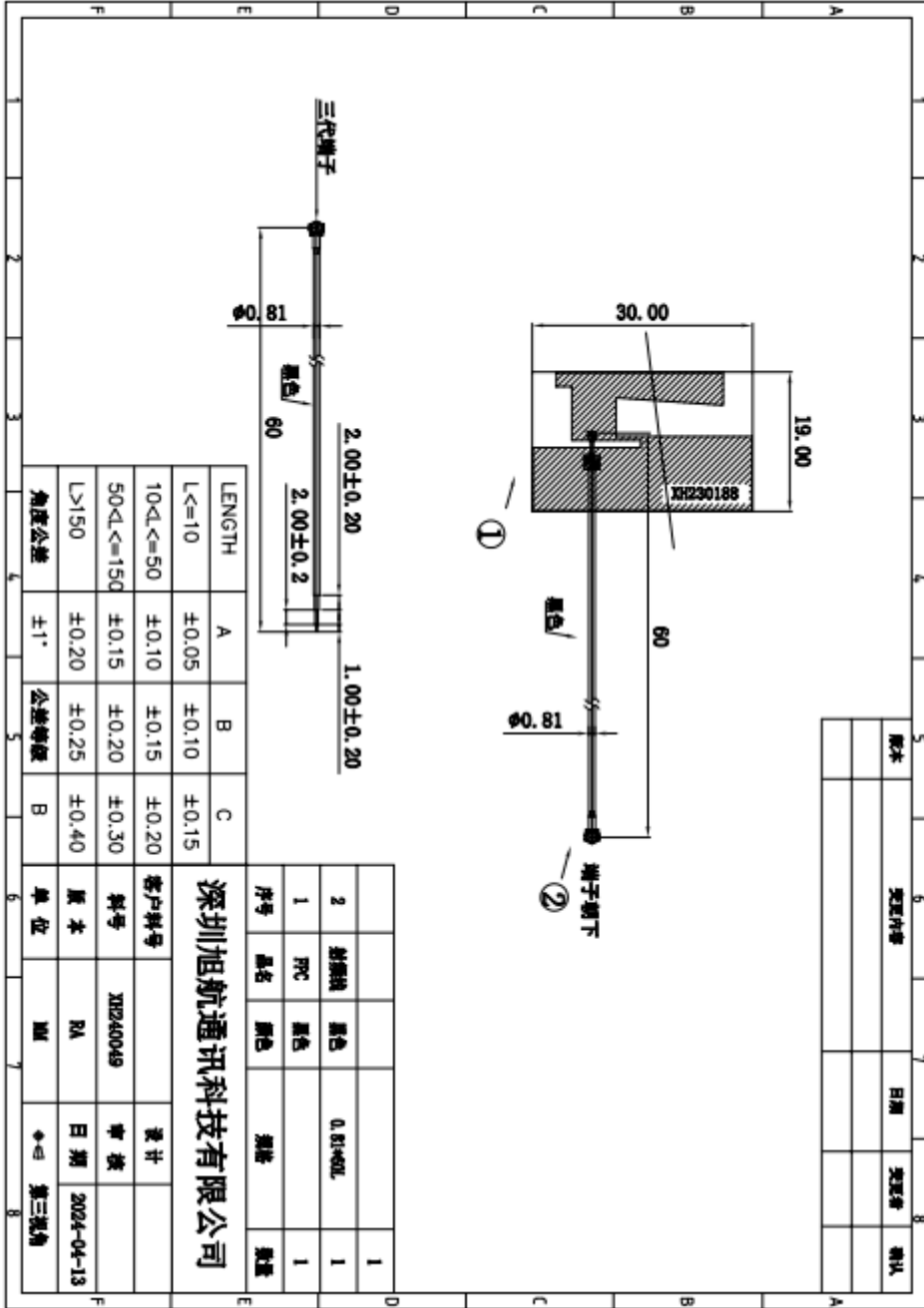

测试数据

Test Data

Freq (MHz)	Effi (%)	Gain (dBi)
2400	46.91	1.11
2410	42.88	0.77
2420	50.03	1.75
2430	50.24	1.76
2440	51.68	2.03
2450	46.72	1.48
2460	42.53	1.09
2470	46.39	1.46
2480	42.76	0.84
2490	49.77	1.53
2500	42.98	0.61

Freq (MHz)	Effi (%)	Gain (dBi)
5150	43.66	1.53
5550	46.63	1.77
5850	45.24	1.68

方向图

2440.000MHz H

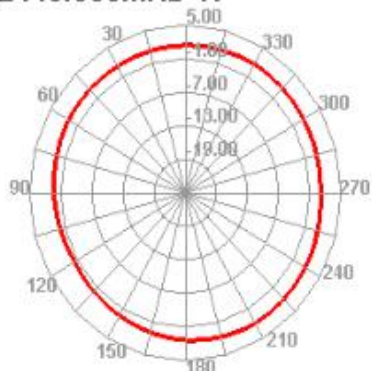

2440.000MHz E1

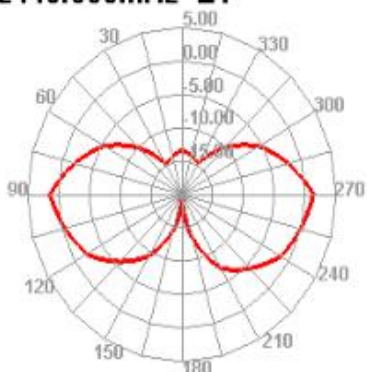

2440.000MHz E2

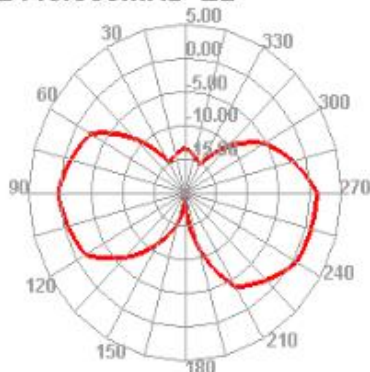

5150.000MHz H

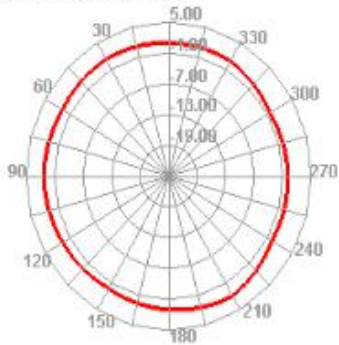

5150.000MHz E1

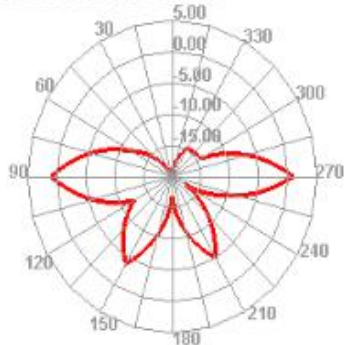

5150.000MHz E2

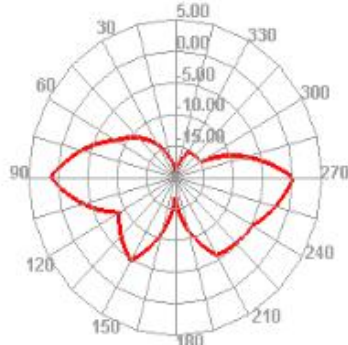

无源驻波

