



# TEST REPORT

## FCC PART 15.247

Report Reference No.....: **CTL2311242081-WF03**

Compiled by: Happy Guo  
( position+printed name+signature) (File administrators)

Tested by: Yapeng Jin  
( position+printed name+signature) (Test Engineer)

Approved by: Ivan Xie  
( position+printed name+signature) (Manager)

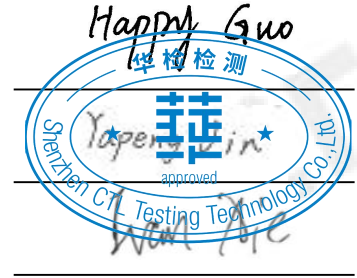

Product Name.....: Car multimedia infotainment system

Model/Type reference.....: Q1062LT22A

List Model(s).....: N/A

Trade Mark.....: RoadRover

FCC ID.....: **2BFQL-Q1062LT22A**

Applicant's name.....: **Dongguan RoadRover Intelligent Technology Co., Ltd.**

Address of applicant.....: No.28, Luxi 1st Road, Xixi Village,Liaobu Town, Dongguan City,Guangdong Province,P.R.China

Test Firm.....: **Shenzhen CTL Testing Technology Co., Ltd.**

Address of Test Firm.....: Floor 1-A, Baisha Technology Park, No.3011, Shahexi Road, Nanshan District, Shenzhen, China 518055

Test specification.....:  
Standard.....: **FCC Part 15.247: Operation within the bands 902-928 MHz, 2400-2483.5 MHz and 5725-5850 MHz.**

TRF Originator.....: Shenzhen CTL Testing Technology Co., Ltd.

Master TRF.....: Dated 2011-01

Date of receipt of test item.....: Dec. 04, 2023

Date of Test Date.....: Dec. 05, 2023 - Feb. 02, 2024

Date of Issue.....: Feb. 23, 2024

Result.....: **Pass**

**Shenzhen CTL Testing Technology Co., Ltd. All rights reserved.**

This publication may be reproduced in whole or in part for non-commercial purposes as long as the Shenzhen CTL Testing Technology Co., Ltd. is acknowledged as copyright owner and source of the material. Shenzhen CTL Testing Technology Co., Ltd. takes no responsibility for and will not assume liability for damages resulting from the reader's interpretation of the reproduced material due to its placement and context.

# TEST REPORT

|                          |                           |                                |
|--------------------------|---------------------------|--------------------------------|
| <b>Test Report No. :</b> | <b>CTL2311242081-WF03</b> | Feb. 23, 2024<br>Date of issue |
|--------------------------|---------------------------|--------------------------------|

Equipment under Test : Car multimedia infotainment system

Sample No : CTL2311242081

Model /Type : Q1062LT22A

Listed Models : N/A

**Applicant** : **Dongguan RoadRover Intelligent Technology Co., Ltd.**

Address : No.28, Luxi 1st Road, Xixi Village, Liaobu Town, Dongguan City, Guangdong Province, P.R.China

**Manufacturer** : **Dongguan RoadRover Intelligent Technology Co., Ltd.**

Address : No.28, Luxi 1st Road, Xixi Village, Liaobu Town, Dongguan City, Guangdong Province, P.R.China

|                    |               |
|--------------------|---------------|
| <b>Test result</b> | <b>Pass *</b> |
|--------------------|---------------|

\* In the configuration tested, the EUT complied with the standards specified page 5.

The test results presented in this report relate only to the object tested.

This report shall not be reproduced, except in full, without the written approval of the issuing testing laboratory.



## Table of Contents

Page

|   |           |
|---|-----------|
| <b>1. SUMMARY</b> .....                                 | <b>5</b>  |
| 1.1. TEST STANDARDS .....                               | 5         |
| 1.2. TEST DESCRIPTION .....                             | 5         |
| 1.3. TEST FACILITY .....                                | 6         |
| 1.4. STATEMENT OF THE MEASUREMENT UNCERTAINTY .....     | 6         |
| <b>2. GENERAL INFORMATION</b> .....                     | <b>8</b>  |
| 2.1. ENVIRONMENTAL CONDITIONS .....                     | 8         |
| 2.2. GENERAL DESCRIPTION OF EUT .....                   | 8         |
| 2.3. DESCRIPTION OF TEST MODES AND TEST FREQUENCY ..... | 9         |
| 2.4. EQUIPMENTS USED DURING THE TEST .....              | 10        |
| 2.5. RELATED SUBMITTAL(S) / GRANT (S) .....             | 11        |
| 2.6. MODIFICATIONS .....                                | 11        |
| <b>3. TEST CONDITIONS AND RESULTS</b> .....             | <b>12</b> |
| 3.1. CONDUCTED EMISSIONS TEST .....                     | 12        |
| 3.2. RADIATED EMISSIONS AND BAND EDGE .....             | 15        |
| 3.3. MAXIMUM CONDUCTED OUTPUT POWER .....               | 29        |
| 3.4. POWER SPECTRAL DENSITY .....                       | 30        |
| 3.5. 6DB BANDWIDTH .....                                | 31        |
| 3.6. OUT-OF-BAND EMISSIONS .....                        | 32        |
| 3.7. ANTENNA REQUIREMENT .....                          | 33        |
| <b>4. TEST SETUP PHOTOS OF THE EUT</b> .....            | <b>33</b> |
| <b>5. PHOTOS OF THE EUT</b> .....                       | <b>35</b> |

# 1. SUMMARY

## 1.1. TEST STANDARDS

The tests were performed according to following standards:

[FCC Rules Part 15.247](#): Frequency Hopping, Direct Spread Spectrum and Hybrid Systems that are in operation within the bands of 902-928 MHz, 2400-2483.5 MHz, and 5725-5850 MHz

[ANSI C63.10: 2013](#): American National Standard for Testing Unlicensed Wireless Devices

[KDB 558074 D01 15.247 Meas Guidance v05r02](#) : Guidance for Performing Compliance Measurements on Digital Transmission Systems (DTS) Operating Under §15.247

## 1.2. Test Description

| FCC PART 15.247                 |                                |      |
|---------------------------------|--------------------------------|------|
| FCC Part 15.207                 | AC Power Conducted Emission    | PASS |
| FCC Part 15.247(a)(2)           | 6dB Bandwidth                  | PASS |
| FCC Part 15.247(d)              | Spurious RF Conducted Emission | PASS |
| FCC Part 15.247(b)              | Maximum Conducted Output Power | PASS |
| FCC Part 15.247(e)              | Power Spectral Density         | PASS |
| FCC Part 15.109/ 15.205/ 15.209 | Radiated Emissions             | PASS |
| FCC Part 15.247(d)              | Band Edge                      | PASS |
| FCC Part 15.203/15.247 (b)      | Antenna Requirement            | PASS |

## 1.3. Test Facility

### 1.3.1 Address of the test laboratory

Shenzhen CTL Testing Technology Co.,Ltd.

Floor 1-A, Baisha Technology Park, No.3011, Shahexi Road, Nanshan District, Shenzhen, China 518055

There is one 3m semi-anechoic chamber and two line conducted labs for final test. The Test Sites meet the requirements in documents ANSI C63.10 and CISPR 22/EN 55022 requirements.

### 1.3.2 Laboratory accreditation

The test facility is recognized, certified, or accredited by the following organizations:

#### **CNAS-Lab Code: L7497**

Shenzhen CTL Testing Technology Co., Ltd. has been assessed and proved to be in compliance with CNAS-CL01 Accreditation Criteria for Testing and Calibration Laboratories (identical to ISO/IEC 17025: 2017 General Requirements) for the Competence of Testing and Calibration Laboratories.

#### **A2LA-Lab Cert. No. 4343.01**

Shenzhen CTL Testing Technology Co., Ltd, EMC Laboratory has been accredited by A2LA for technical competence in the field of electrical testing, and proved to be in compliance with ISO/IEC 17025: 2017 General Requirements for the Competence of Testing and Calibration Laboratories and any additional program requirements in the identified field of testing.

#### **IC Registration No.: 9618B**

#### **CAB identifier: CN0041**

The 3m alternate test site of Shenzhen CTL Testing Technology Co., Ltd. EMC Laboratory has been registered by Innovation, Science and Economic Development Canada to test to Canadian radio equipment requirements with Registration No.: 9618B on Jan. 22, 2019.

#### **FCC-Registration No.: 399832**

#### **Designation No.: CN1216**

Shenzhen CTL Testing Technology Co., Ltd. EMC Laboratory has been registered and fully described in a report filed with the (FCC) Federal Communications Commission. The acceptance letter from the FCC is maintained in our files. Registration 399832, December 08, 2017.

## 1.4. Statement of the measurement uncertainty

The data and results referenced in this document are true and accurate. The reader is cautioned that there may be errors within the calibration limits of the equipment and facilities. The measurement uncertainty was calculated for all measurements listed in this test report acc. to CISPR 16 - 4 "Specification for radio disturbance and immunity measuring apparatus and methods – Part 4: Uncertainty in EMC Measurements" and is documented in the Shenzhen CTL Testing Technology Co., Ltd. quality system acc. to DIN EN ISO/IEC 17025. Furthermore, component and process variability of devices similar to that tested may result in additional deviation. The manufacturer has the sole responsibility of continued compliance of the device.

Hereafter the best measurement capability for CTL laboratory is reported:

| Test  | Measurement Uncertainty                                 | Notes |
|---|---|-------|
| Transmitter power Radiated                      | $\pm 2.20$ dB   | (1)   |
| Radiated Emission 9KHz~30MHz                    | $\pm 3.66$ dB   | (1)   |
| Radiated Emission 30~1000MHz                    | $\pm 4.10$ dB   | (1)   |
| Radiated Emission Above 1GHz                    | $\pm 4.32$ dB   | (1)   |
| DTS Bandwidth                                   | $\pm 1.9\%$   | (1)   |
| Maximum Conducted Output Power                  | $\pm 1.18$ dB   | (1)   |
| Maximum Power Spectral Density Level            | $\pm 0.98$ dB   | (1)   |
| Band-edge                                       | $\pm 1.21$ dB   | (1)   |
| Unwanted Emissions In Non-restricted Freq Bands | 9kHz-7GHz: $\pm 1.09$ dB<br>7GHz-26.5GHz: $\pm 3.27$ dB | (1)   |

- (1) This uncertainty represents an expanded uncertainty expressed at approximately the 95% confidence level using a coverage factor of  $k=2$ .

## 2. GENERAL INFORMATION

### 2.1. Environmental conditions

During the measurement the environmental conditions were within the listed ranges:

|                     |         |
|---------------------|---------|
| Normal Temperature: | 25°C    |
| Relative Humidity:  | 55 %    |
| Air Pressure:       | 101 kPa |

### 2.2. General Description of EUT

|                       |  |
|-----------------------|--|
| Product Name:         | Car multimedia infotainment system   |
| Model/Type reference: | Q1062LT22A   |
| Power supply:         | DC 12V   |
| <b>2.4G WIFI</b>      |  |
| Supported type:       | 802.11b/802.11g/802.11n(H20)/802.11n(H40)                                      |
| Modulation:           | 802.11b: DSSS<br>802.11g/802.11n(H20)/802.11n(H40): OFDM                       |
| Operation frequency:  | 802.11b/802.11g/802.11n(H20): 2412MHz~2462MHz<br>802.11n(H40): 2422MHz~2452MHz |
| Channel number:       | 802.11b/802.11g/802.11n(H20): 11<br>802.11n(H40): 7                            |
| Channel separation:   | 802.11b/802.11g/802.11n(H20)/802.11n(H40)                                      |
| Antenna type:         | Ceramic Antenna  |
| Antenna gain:         | 1.50dBi  |

Note1: For more details, please refer to the user' s manual of the EUT.

Note2: Antenna gain provided by the applicant.

Note3: This report is for 2.4G WIFI only.

Note4: Directional gain = GANT MAX + 10 log(NANT/NSS) dBi, where NSS = the number of independent spatial streams of data and GANT MAX is the gain of the antenna having the highest gain (in dBi)



## 2.3. Description of Test Modes and Test Frequency

The Applicant provides communication tools software to control the EUT for staying in continuous transmitting (Duty Cycle more than 98%) and receiving mode for testing.

There are 11 channels provided to the EUT and Channel 01/03/06/09/11 were selected for WIFI test.

### Operation Frequency WIFI :

| Channel  | Frequency(MHz) | Channel   | Frequency(MHz) |
|----------|----------------|-----------|----------------|
| <b>1</b> | <b>2412</b>    | 8         | 2447           |
| 2        | 2417           | <b>9</b>  | <b>2452</b>    |
| <b>3</b> | <b>2422</b>    | 10        | 2457           |
| 4        | 2427           | <b>11</b> | <b>2462</b>    |
| 5        | 2432           |           |                |
| <b>6</b> | <b>2437</b>    |           |                |
| 7        | 2442           |           |                |

Note: The line display in grey were the channel selected for testing

### Data Rate Used:

Preliminary tests were performed in different data rate to find the worst radiated emission. The data rate shown in the table below is the worst-case rate with respect to the specific test item. Investigation has been done on all the possible configurations for searching the worst cases. The following table is a list of the test modes shown in this test report.

| Test Items  | Mode            | Data Rate | Channel |
|---|-----------------|-----------|---------|
| Maximum Conducted Output Power<br>Power Spectral Density<br>6dB Bandwidth<br>Spurious RF conducted emission<br>Radiated Emission 9kHz~1GHz&<br>Radiated Emission 1GHz~10th Harmonic | 11b/DSSS        | 1 Mbps    | 1/6/11  |
|   | 11g/OFDM        | 6 Mbps    | 1/6/11  |
|   | 11n(20MHz)/OFDM | 6.5Mbps   | 1/6/11  |
|   | 11n(40MHz)/OFDM | 13.5Mbps  | 3/6/9   |
| Band Edge   | 11b/DSSS        | 1 Mbps    | 1/11    |
|   | 11g/OFDM        | 6 Mbps    | 1/11    |
|   | 11n(20MHz)/OFDM | 6.5Mbps   | 1/11    |
|   | 11n(40MHz)/OFDM | 13.5Mbps  | 3/9     |

## 2.4. Equipments Used during the Test

| Conducted Emission |                   |                 |           |              |            |            |
|--------------------|-------------------|-----------------|-----------|--------------|------------|------------|
| Item               | Test Equipment    | Manufacturer    | Model No. | Serial No.   | Last Cal.  | Cal.Due    |
|                    | EMI Test Receiver | ROHDE & SCHWARZ | ESCI      | 1166.5950.03 | 2023/05/04 | 2024/05/03 |
|                    | LISN              | ROHDE & SCHWARZ | ESH2-Z5   | 860014/010   | 2023/05/04 | 2024/05/03 |
|                    | Limitator         | ROHDE & SCHWARZ | ESH3-Z2   | 100408       | 2023/05/04 | 2024/05/03 |
| Software:          |                   |                 |           |              |            |            |
| Name of Software:  |                   |                 |           | Version:     |            |            |
| ES-K1              |                   |                 |           | V1.71        |            |            |

| Radiated Emissions and Band Edge |                      |            |              |                  |                      |
|----------------------------------|----------------------|------------|--------------|------------------|----------------------|
| Test Equipment                   | Manufacturer         | Model No.  | Serial No.   | Calibration Date | Calibration Due Date |
| Active Loop Antenna              | Da Ze                | ZN30900A   | 0703         | 2021/05/13       | 2024/05/12           |
| Double cone logarithmic antenna  | Schwarzbeck          | VULB 9168  | 824          | 2023/02/13       | 2026/02/12           |
| Horn Antenna                     | Sunol Sciences Corp. | DRH-118    | A062013      | 2021/12/23       | 2024/12/22           |
| Horn Antenna                     | Ocean Microwave      | OBH1004 00 | 26999002     | 2021/12/22       | 2024/12/21           |
| Amplifier                        | MRT-AP01M 06         | MRT        | S-001        | 2023/05/04       | 2024/05/03           |
| Amplifier                        | Agilent              | 8449B      | 3008A02306   | 2023/05/04       | 2024/05/03           |
| Amplifier                        | Brief&Smart          | LNA-4018   | 2104197      | 2023/05/05       | 2024/05/04           |
| EMI Test Receiver                | ROHDE & SCHWARZ      | ESCI       | 1166.5950.03 | 2023/05/04       | 2024/05/03           |
| Spectrum Analyzer                | RS                   | FSP        | 1164.4391.38 | 2023/05/05       | 2024/05/04           |
| Test software                    |                      |            |              |                  |                      |
| Name of Software                 |                      |            | Version      |                  |                      |
| EZ_EMG(Below 1GHz)               |                      |            | V1.1.4.2     |                  |                      |
| EZ_EMG(Above 1GHz)               |                      |            | V1.1.4.2     |                  |                      |

| Maximum Conducted Output Power & Power Spectral Density & 6dB Bandwidth & Out-of-band Emissions |              |           |            |                  |                      |
|---|--------------|-----------|------------|------------------|----------------------|
| Test Equipment  | Manufacturer | Model No. | Serial No. | Calibration Date | Calibration Due Date |
| Spectrum Analyzer   | Keysight     | N9020A    | MY53420874 | 2023/05/04       | 2024/05/03           |
| Temperature/Humidity Meter  | Ji Yu        | MC501     | /          | 2023/05/09       | 2024/05/08           |
| Test Software   |              |           |            |                  |                      |

| Name of Software | Version |
|------------------|---------|
| TST-PASS         | V2.0    |

## 2.5. Related Submittal(s) / Grant (s)

This submittal(s) (test report) is intended to comply with Section 15.247 of the FCC Part 15, Subpart C Rules.

## 2.6. Modifications

No modifications were implemented to meet testing criteria.

### 3. TEST CONDITIONS AND RESULTS

#### 3.1. Conducted Emissions Test

##### LIMIT

FCC CFR Title 47 Part 15 Subpart C Section 15.207

| Frequency range (MHz) | Limit (dBuV) |           |
|-----------------------|--------------|-----------|
|                       | Quasi-peak   | Average   |
| 0.15-0.5              | 66 to 56*    | 56 to 46* |
| 0.5-5                 | 56           | 46        |
| 5-30                  | 60           | 50        |

\* Decreases with the logarithm of the frequency.

##### TEST CONFIGURATION

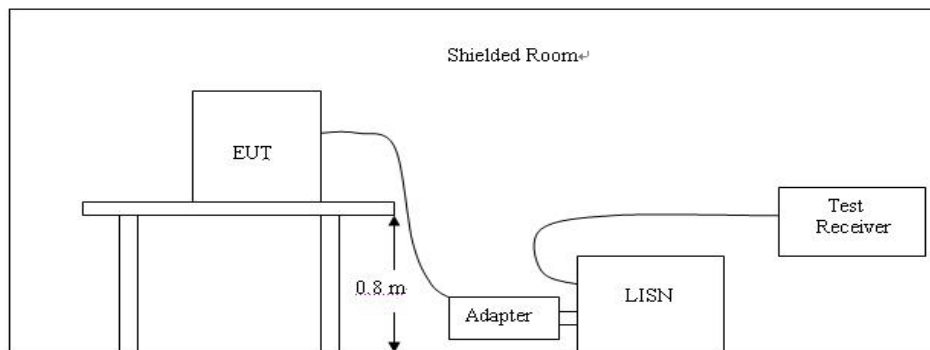

##### TEST PROCEDURE

1. The equipment was set up as per the test configuration to simulate typical actual usage per the user's manual. The EUT is a bObsweep Pet Hair Vision Plus Robot Vacuum Cleaner op system; a wooden table with a height of 0.8 meters is used and is placed on the ground plane as per ANSI C63.10:2013.
2. Support equipment, if needed, was placed as per ANSI C63.10:2013.
3. All I/O cables were positioned to simulate typical actual usage as per ANSI C63.10:2013.
4. The adapter received AC120V/60Hz power through a Line Impedance Stabilization Network (LISN) which supplied power source and was grounded to the ground plane.
5. All support equipments received AC power from a second LISN, if any.
6. The EUT test program was started. Emissions were measured on each current carrying line of the EUT using a spectrum Analyzer / Receiver connected to the LISN powering the EUT. The LISN has two monitoring points: Line 1 (Hot Side) and Line 2 (Neutral Side). Two scans were taken: one with Line 1 connected to Analyzer / Receiver and Line 2 connected to a 50 ohm load; the second scan had Line 1 connected to a 50 ohm load and Line 2 connected to the Analyzer / Receiver.
7. Analyzer / Receiver scanned from 150 KHz to 30MHz for emissions in each of the test modes.
8. During the above scans, the emissions were maximized by cable manipulation.

**TEST RESULTS**

Remark:802.11b/802.11g/802.11n(H20)mode all have been tested ,only worse case is reported.

|                  |             |              |          |
|------------------|-------------|--------------|----------|
| <b>Test Mode</b> | <b>WIFI</b> | <b>Line:</b> | <b>L</b> |
|------------------|-------------|--------------|----------|

*Shenzhen CTL Testing Technology Co., Ltd.*

**Voltage Mains Test FCC PART 15 C**

EUT: Q1062LT22A  
 Manufacturer: Shenzhen RoadRover Technology Co., Ltd  
 Operating Condition: WIFI2.4G 2412MHz  
 Test Site: /  
 Operator: JYP  
 Test Specification: DC 12V  
 Comment: /  
 Start of Test: 12/12/2023 / 8:38:11PM

**SCAN TABLE: "Voltage (9K-30M) FIN"**  
 Short Description: 150K-30M Voltage

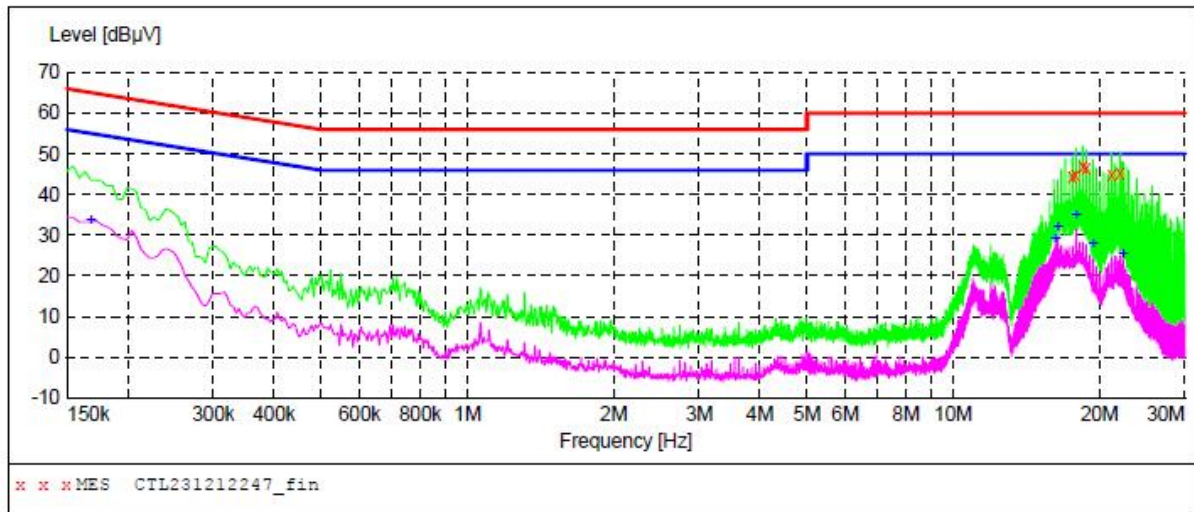

**MEASUREMENT RESULT: "CTL231212247\_fin"**

12/12/2023 8:40PM

| Frequency MHz | Level dBµV | Transd dB | Limit dBµV | Margin dB | Detector | Line | PE  |
|---------------|------------|-----------|------------|-----------|----------|------|-----|
| 17.601000     | 44.40      | 11.2      | 60         | 15.6      | QP       | L1   | GND |
| 17.893500     | 44.70      | 11.2      | 60         | 15.3      | QP       | L1   | GND |
| 18.496500     | 47.00      | 11.2      | 60         | 13.0      | QP       | L1   | GND |
| 18.798000     | 46.50      | 11.2      | 60         | 13.5      | QP       | L1   | GND |
| 21.187500     | 45.00      | 11.0      | 60         | 15.0      | QP       | L1   | GND |
| 22.078500     | 45.30      | 10.9      | 60         | 14.7      | QP       | L1   | GND |

**MEASUREMENT RESULT: "CTL231212247\_fin2"**

12/12/2023 8:40PM

| Frequency MHz | Level dBµV | Transd dB | Limit dBµV | Margin dB | Detector | Line | PE  |
|---------------|------------|-----------|------------|-----------|----------|------|-----|
| 0.168000      | 33.50      | 10.0      | 55         | 21.6      | AV       | L1   | GND |
| 16.228500     | 28.90      | 11.2      | 50         | 21.1      | AV       | L1   | GND |
| 16.431000     | 31.80      | 11.2      | 50         | 18.2      | AV       | L1   | GND |
| 17.925000     | 34.70      | 11.2      | 50         | 15.3      | AV       | L1   | GND |
| 19.419000     | 28.00      | 11.2      | 50         | 22.0      | AV       | L1   | GND |
| 22.398000     | 25.40      | 10.9      | 50         | 24.6      | AV       | L1   | GND |

|           |      |       |   |
|-----------|------|-------|---|
| Test Mode | WIFI | Line: | N |
|-----------|------|-------|---|

*Shenzhen CTL Testing Technology Co., Ltd.*

**Voltage Mains Test FCC PART 15 C**

EUT: Q1062LT22A  
 Manufacturer: Shenzhen RoadRover Technology Co., Ltd  
 Operating Condition: WIFI2.4G 2412MHz  
 Test Site: /  
 Operator: JYP  
 Test Specification: DC 12V  
 Comment: /  
 Start of Test: 12/12/2023 / 8:12:59PM

**SCAN TABLE: "Voltage (9K-30M)FIN"**

Short Description: 150K-30M Voltage

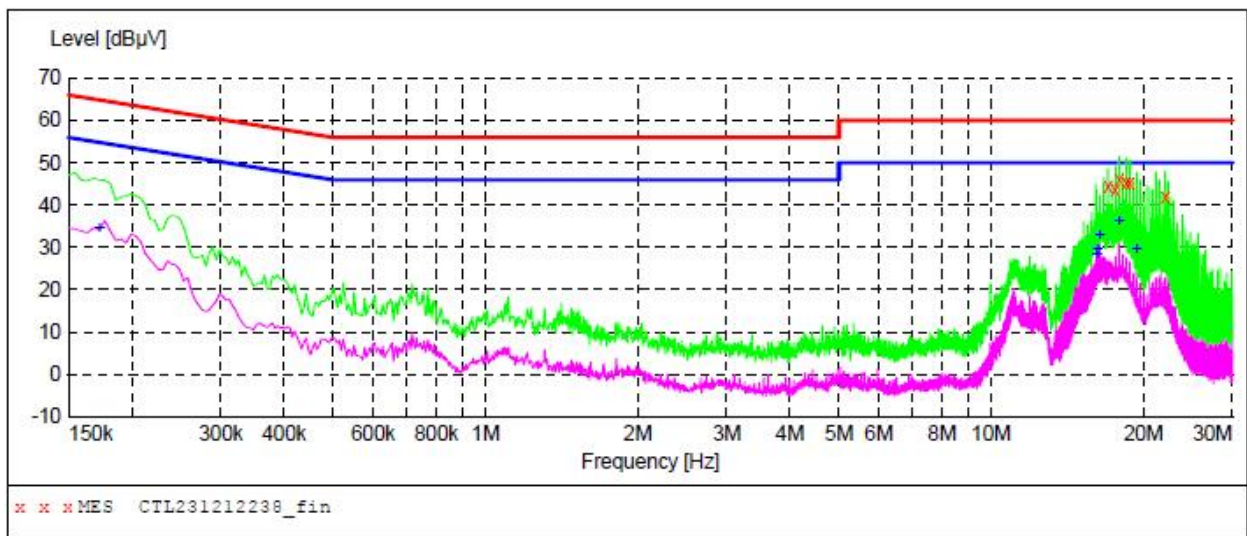

**MEASUREMENT RESULT: "CTL231212238\_fin"**

12/12/2023 8:15PM

| Frequency MHz | Level dBµV | Transd dB | Limit dBµV | Margin dB | Detector | Line | PE  |
|---------------|------------|-----------|------------|-----------|----------|------|-----|
| 17.011500     | 44.40      | 11.2      | 60         | 15.6      | QP       | N    | GND |
| 17.605500     | 43.60      | 11.2      | 60         | 16.4      | QP       | N    | GND |
| 17.911500     | 46.10      | 11.2      | 60         | 13.9      | QP       | N    | GND |
| 18.501000     | 45.30      | 11.2      | 60         | 14.7      | QP       | N    | GND |
| 18.807000     | 45.30      | 11.2      | 60         | 14.7      | QP       | N    | GND |
| 22.092000     | 42.00      | 10.9      | 60         | 18.0      | QP       | N    | GND |

**MEASUREMENT RESULT: "CTL231212238\_fin2"**

12/12/2023 8:15PM

| Frequency MHz | Level dBµV | Transd dB | Limit dBµV | Margin dB | Detector | Line | PE  |
|---------------|------------|-----------|------------|-----------|----------|------|-----|
| 0.172500      | 34.60      | 10.0      | 55         | 20.2      | AV       | N    | GND |
| 16.170000     | 28.30      | 11.2      | 50         | 21.7      | AV       | N    | GND |
| 16.228500     | 29.50      | 11.2      | 50         | 20.5      | AV       | N    | GND |
| 16.399500     | 33.00      | 11.2      | 50         | 17.0      | AV       | N    | GND |
| 17.889000     | 36.00      | 11.2      | 50         | 14.0      | AV       | N    | GND |
| 19.378500     | 29.60      | 11.2      | 50         | 20.4      | AV       | N    | GND |

## 3.2. Radiated Emissions and Band Edge

### Limit

For intentional device, according to § 15.209(a), the general requirement of field strength of radiated emission out of authorized band shall not exceed the following table at a 3 meters measurement distance.

In addition, radiated emissions which fall in the restricted bands, as defined in §15.205(a), must also comply with the radiated emission limits specified in §15.209(a)

Radiated emission limits

| Frequency (MHz) | Distance (Meters) | Radiated (dB $\mu$ V/m)                    | Radiated ( $\mu$ V/m) |
|-----------------|-------------------|--|-----------------------|
| 0.009-0.49      | 3                 | $20\log(2400/F(\text{KHz}))+40\log(300/3)$ | $2400/F(\text{KHz})$  |
| 0.49-1.705      | 3                 | $20\log(24000/F(\text{KHz}))+40\log(30/3)$ | $24000/F(\text{KHz})$ |
| 1.705-30        | 3                 | $20\log(30)+40\log(30/3)$                  | 30                    |
| 30-88           | 3                 | 40.0                                       | 100                   |
| 88-216          | 3                 | 43.5                                       | 150                   |
| 216-960         | 3                 | 46.0                                       | 200                   |
| Above 960       | 3                 | 54.0                                       | 500                   |

### TEST CONFIGURATION

(A) Radiated Emission Test Set-Up, Frequency Below 30MHz

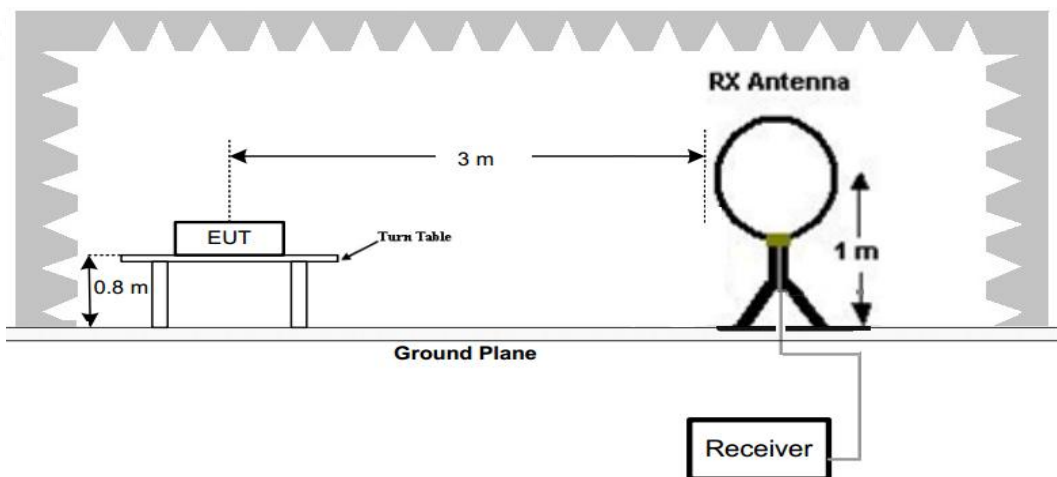

(B) Radiated Emission Test Set-Up, Frequency below 1000MHz

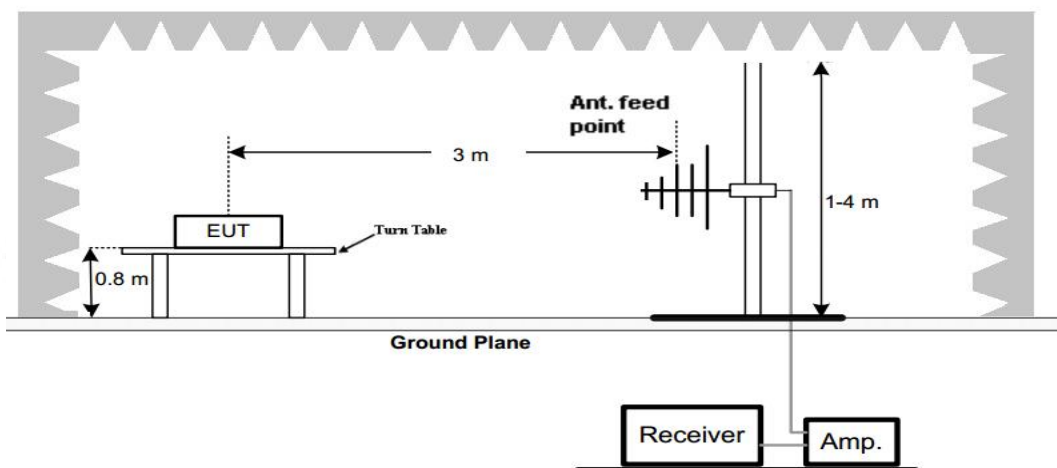

(C) Radiated Emission Test Set-Up, Frequency above 1000MHz

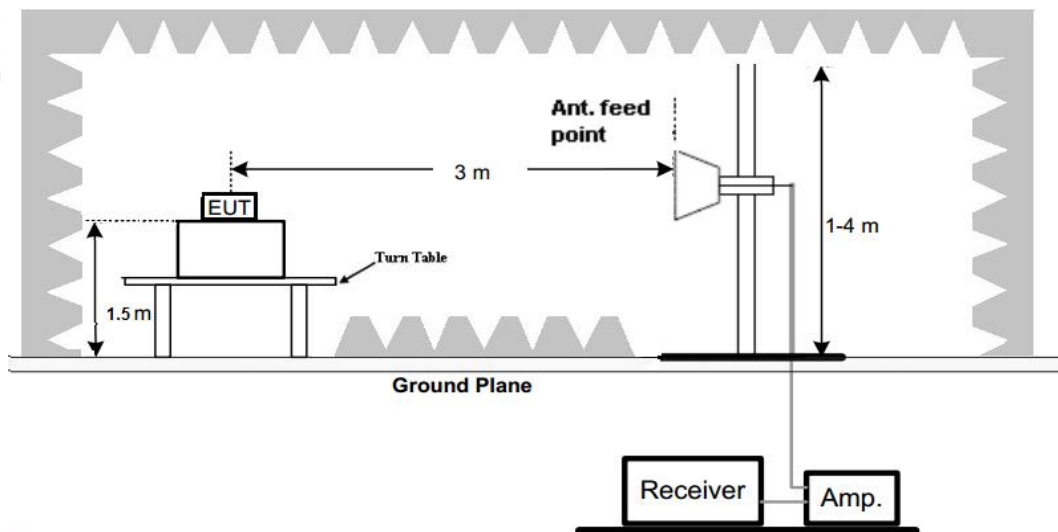

### Test Procedure

1. Below 1GHz measurement the EUT is placed on a turntable which is 0.8m above ground plane, and above 1GHz measurement EUT was placed on a low permittivity and low loss tangent turn table which is 1.5m above ground plane.
2. Maximum procedure was performed by raising the receiving antenna from 1m to 4m and rotating the turn table from 0° to 360° to acquire the highest emissions from EUT
3. And also, each emission was to be maximized by changing the polarization of receiving antenna both horizontal and vertical.
4. Repeat above procedures until all frequency measurements have been completed.
5. The EUT was pretested with 3 orientations placed on the table for the radiated emission measurement –X, Y, and Z-plane. The X-plane results were found as the worst case and were shown in this report.

### TEST RESULTS

Remark:

1. All three channels (lowest/middle/highest) of each mode were measured below 1GHz and recorded worst case at 802.11b low channel.
2. All three channels (lowest/middle/highest) of each mode were measured above 1GHz and recorded worst case at 802.11b mode.
3. Radiated emission test from 9 KHz to 10th harmonic of fundamental was verified, Found the emission level are attenuated 20dB below the limits from 9 kHz to 30MHz, so it does not recorded in report.



For 30MHz-1GHz

|            |      |               |            |
|------------|------|---------------|------------|
| Test mode: | WIFI | Polarization: | Horizontal |
|------------|------|---------------|------------|



Shenzhen CTL Testing Technology Co., Ltd  
Tel: +86-755-89486194

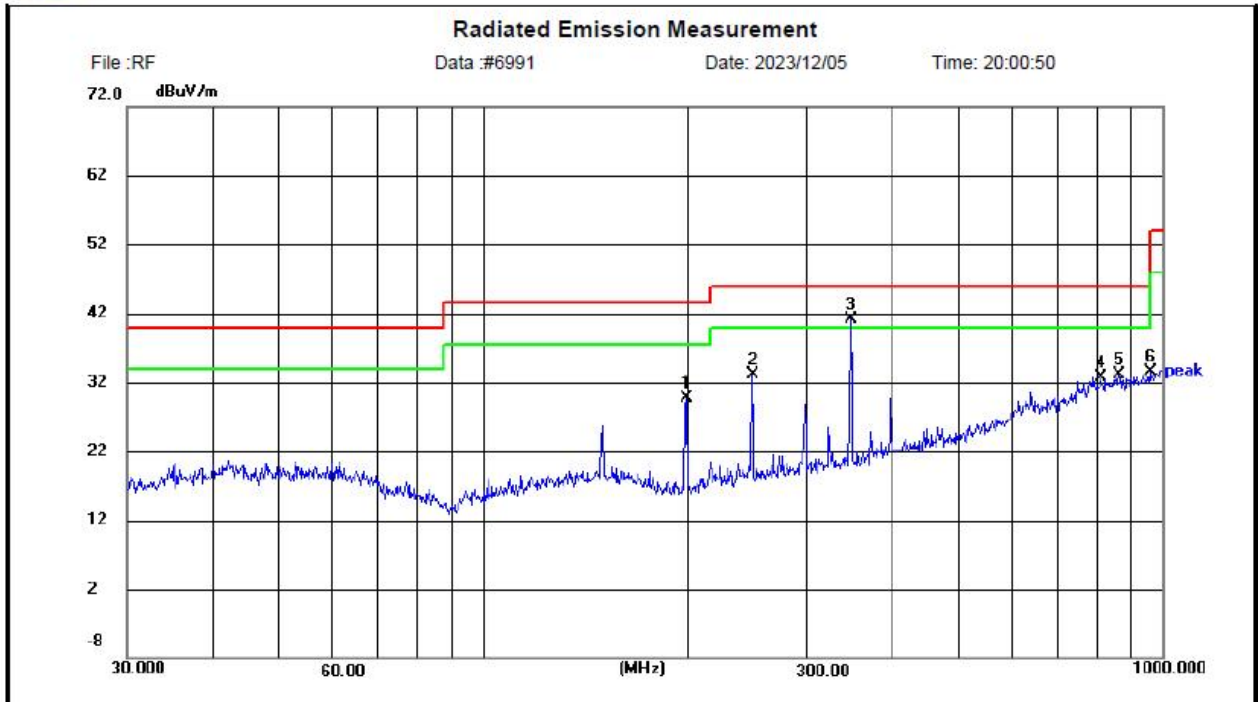

Site: LAB Chamber 2  
Limit: FCC Part15 RE-Class C\_30-1000MHz  
EUT: /  
M/N: Q1062LT22A  
Mode: WIFI2.4G 2412MHz  
Note: Shenzhen RoadRover Technology Co., Ltd

Polarization: **Horizontal**  
Power:  
Distance: 3m

Temperature: 25(C)  
Humidity: 50 %

| No. | Frequency (MHz) | Reading (dBuV) | Factor (dB/m) | Level (dBuV/m) | Limit (dBuV/m) | Margin (dB) | Detector | Height (cm) | Azimuth (deg.) | P/F | Remark |
|-----|-----------------|----------------|---------------|----------------|----------------|-------------|----------|-------------|----------------|-----|--------|
| 1   | 199.2855        | 18.49          | 11.14         | 29.63          | 43.50          | 13.87       | peak     | 100         | 269            | P   |        |
| 2   | 248.5519        | 20.17          | 12.96         | 33.13          | 46.00          | 12.87       | peak     | 100         | 260            | P   |        |
| 3   | 348.0274        | 25.59          | 15.42         | 41.01          | 46.00          | 4.99        | peak     | 100         | 82             | P   |        |
| 4   | 810.2653        | 7.49           | 25.18         | 32.67          | 46.00          | 13.33       | peak     | 100         | 188            | P   |        |
| 5   | 865.7083        | 7.45           | 25.63         | 33.08          | 46.00          | 12.92       | peak     | 100         | 305            | P   |        |
| 6   | 958.7943        | 7.14           | 26.43         | 33.57          | 46.00          | 12.43       | peak     | 100         | 224            | P   |        |

|            |      |               |          |
|------------|------|---------------|----------|
| Test mode: | WIFI | Polarization: | Vertical |
|------------|------|---------------|----------|



Shenzhen CTL Testing Technology Co., Ltd  
Tel: +86-755-89486194

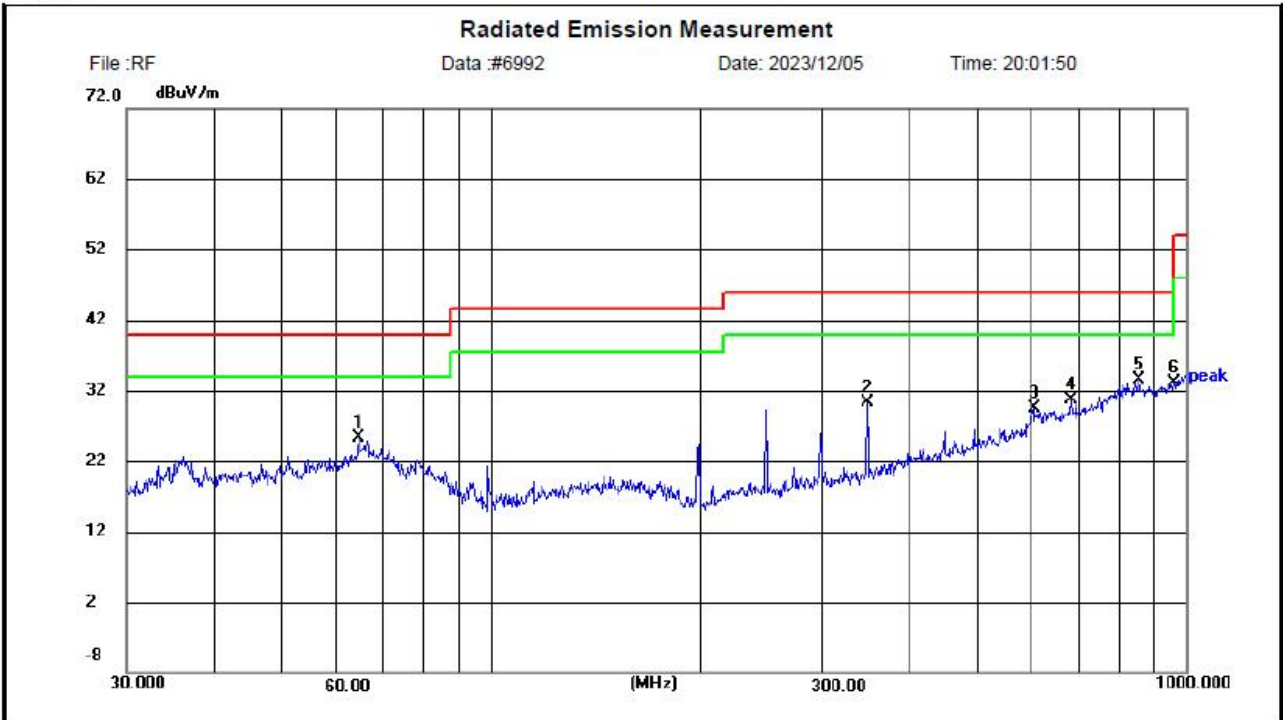

|  |                               |                    |
|--|-------------------------------|--------------------|
| Site LAB Chamber 2                           | Polarization: <i>Vertical</i> | Temperature: 25(C) |
| Limit: FCC Part15 RE-Class C_30-1000MHz      | Power:                        | Humidity: 50 %     |
| EUT: /                                       | Distance: 3m                  |                    |
| M/N: Q1062LT22A                              |                               |                    |
| Mode: WIFI2.4G 2412MHz                       |                               |                    |
| Note: Shenzhen RoadRover Technology Co., Ltd |                               |                    |

| No. | Frequency (MHz) | Reading (dBuV) | Factor (dB/m) | Level (dBuV/m) | Limit (dBuV/m) | Margin (dB) | Detector | Height (cm) | Azimuth (deg.) | P/F | Remark |
|-----|-----------------|----------------|---------------|----------------|----------------|-------------|----------|-------------|----------------|-----|--------|
| 1   | 64.6594         | 12.36          | 12.86         | 25.22          | 40.00          | 14.78       | peak     | 100         | 197            | P   |        |
| 2   | 348.0274        | 14.94          | 15.42         | 30.36          | 46.00          | 15.64       | peak     | 100         | 2              | P   |        |
| 3   | 603.5392        | 8.20           | 21.29         | 29.49          | 46.00          | 16.51       | peak     | 100         | 179            | P   |        |
| 4   | 682.3484        | 8.53           | 22.12         | 30.65          | 46.00          | 15.35       | peak     | 100         | 11             | P   |        |
| 5   | 854.0247        | 7.86           | 25.60         | 33.46          | 46.00          | 12.54       | peak     | 100         | 19             | P   |        |
| 6   | 958.7943        | 6.68           | 26.43         | 33.11          | 46.00          | 12.89       | peak     | 100         | 332            | P   |        |

**For 1GHz to 25GHz**

**802.11b Mode (above 1GHz)**

Note: 802.11b/802.11g/802.11n (H20) /802.11n (H40) all have been tested, only worse case 802.11b is reported

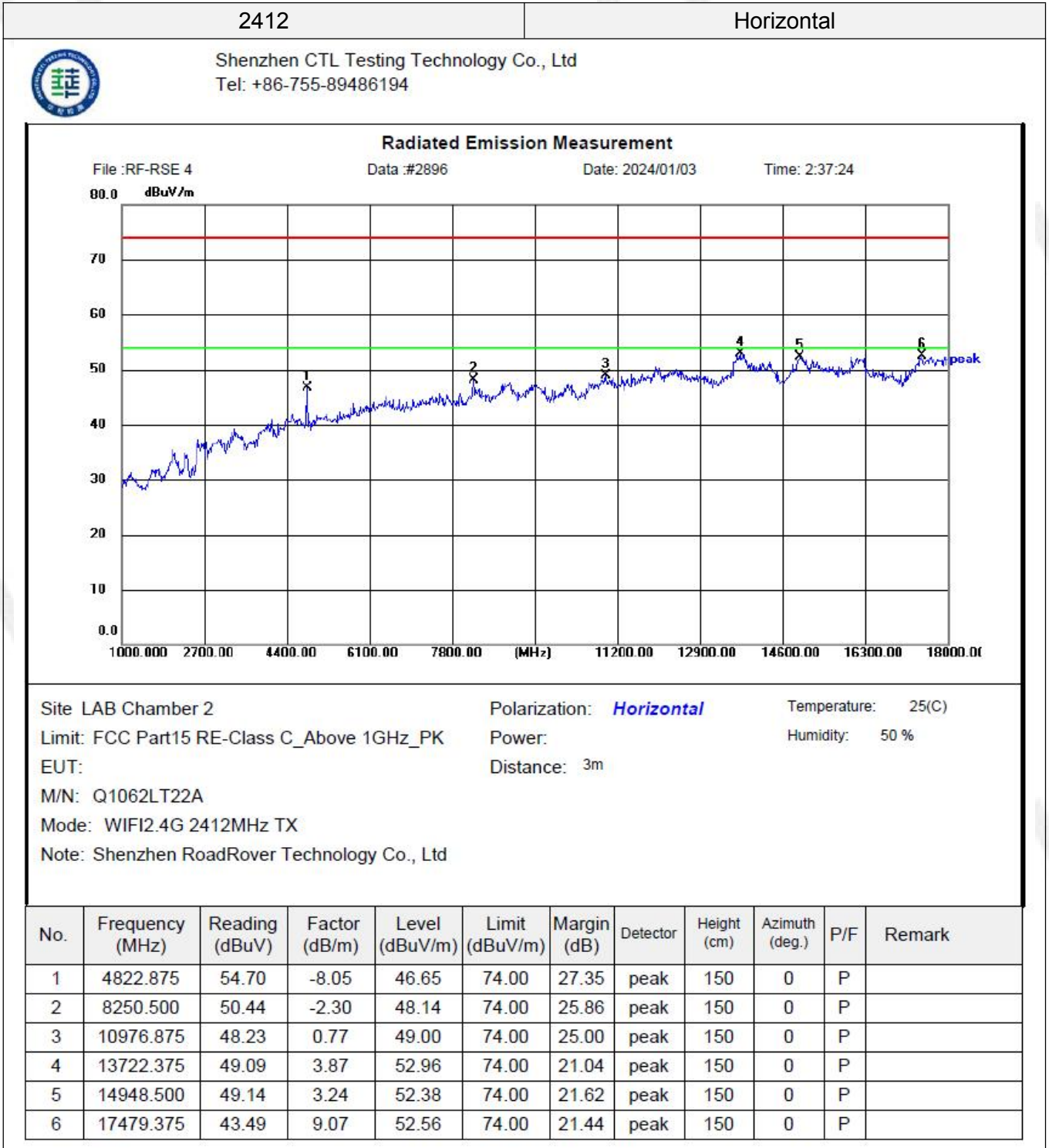

2412

Vertical



Shenzhen CTL Testing Technology Co., Ltd  
Tel: +86-755-89486194

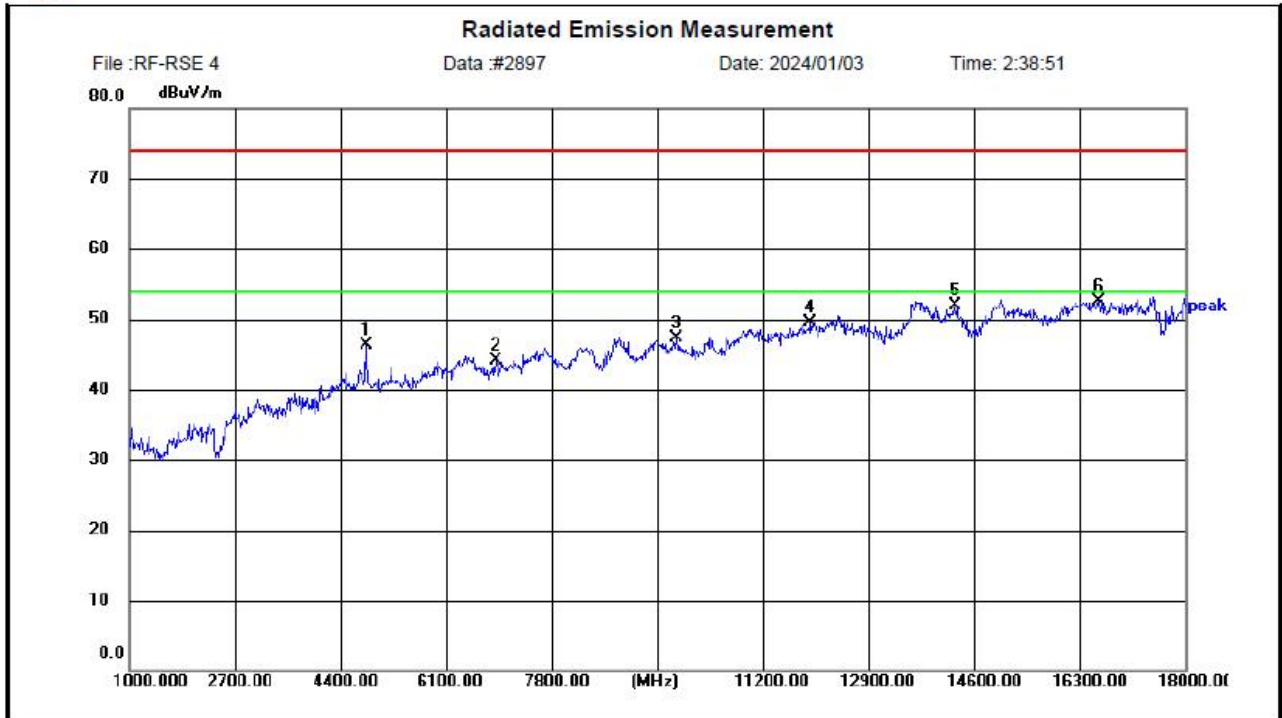

Site LAB Chamber 2      Polarization: **Vertical**      Temperature: 25(C)  
 Limit: FCC Part15 RE-Class C\_Above 1GHz\_PK      Power:      Humidity: 50 %  
 EUT:      Distance: 3m  
 M/N: Q1062LT22A  
 Mode: WIFI2.4G 2412MHz TX  
 Note: Shenzhen RoadRover Technology Co., Ltd

| No. | Frequency (MHz) | Reading (dBuV) | Factor (dB/m) | Level (dBuV/m) | Limit (dBuV/m) | Margin (dB) | Detector | Height (cm) | Azimuth (deg.) | P/F | Remark |
|-----|-----------------|----------------|---------------|----------------|----------------|-------------|----------|-------------|----------------|-----|--------|
| 1   | 4822.875        | 54.31          | -8.05         | 46.26          | 74.00          | 27.74       | peak     | 150         | 360            | P   |        |
| 2   | 6901.125        | 47.98          | -3.95         | 44.03          | 74.00          | 29.97       | peak     | 150         | 360            | P   |        |
| 3   | 9806.000        | 46.84          | 0.53          | 47.37          | 74.00          | 26.63       | peak     | 150         | 360            | P   |        |
| 4   | 11977.750       | 47.43          | 2.14          | 49.57          | 74.00          | 24.43       | peak     | 150         | 360            | P   |        |
| 5   | 14294.000       | 48.98          | 2.83          | 51.81          | 74.00          | 22.19       | peak     | 150         | 360            | P   |        |
| 6   | 16608.125       | 46.30          | 6.29          | 52.59          | 74.00          | 21.41       | peak     | 150         | 360            | P   |        |

2437

Horizontal



Shenzhen CTL Testing Technology Co., Ltd  
Tel: +86-755-89486194

**Radiated Emission Measurement**

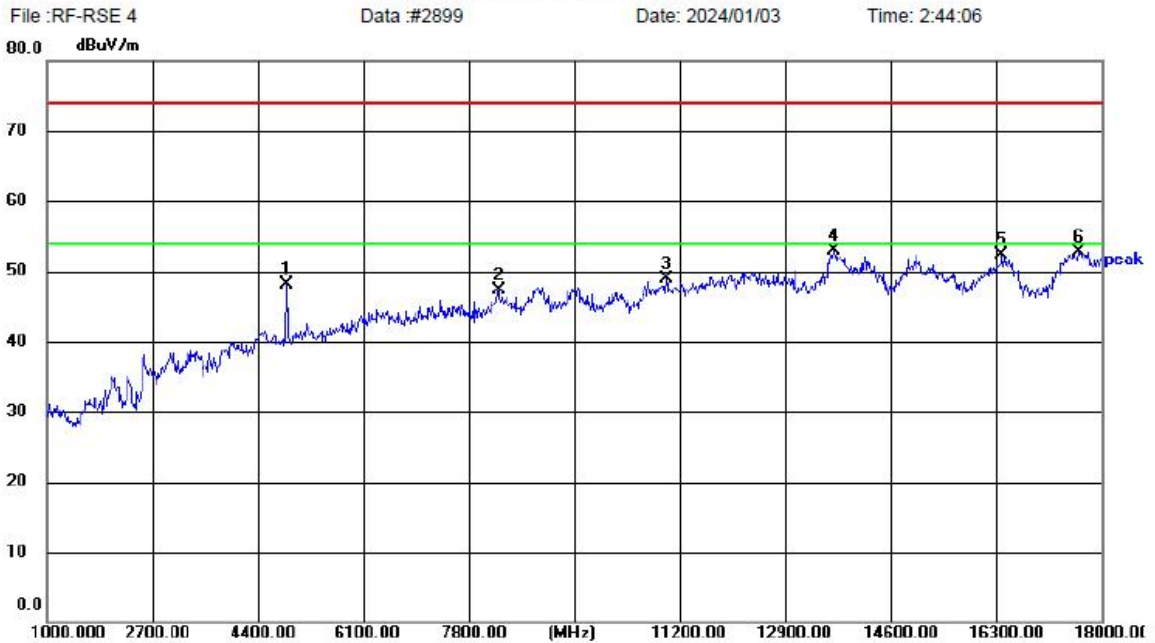

Site LAB Chamber 2      Polarization: **Horizontal**      Temperature: 25(C)  
 Limit: FCC Part15 RE-Class C\_Above 1GHz\_PK      Power:      Humidity: 50 %  
 EUT:      Distance: 3m  
 M/N: Q1062LT22A  
 Mode: WIFI2.4G 2437MHz TX  
 Note: Shenzhen RoadRover Technology Co., Ltd

| No. | Frequency (MHz) | Reading (dBuV) | Factor (dB/m) | Level (dBuV/m) | Limit (dBuV/m) | Margin (dB) | Detector | Height (cm) | Azimuth (deg.) | P/F | Remark |
|-----|-----------------|----------------|---------------|----------------|----------------|-------------|----------|-------------|----------------|-----|--------|
| 1   | 4873.875        | 56.17          | -7.97         | 48.20          | 74.00          | 25.80       | peak     | 150         | 360            | P   |        |
| 2   | 8282.375        | 49.62          | -2.24         | 47.38          | 74.00          | 26.62       | peak     | 150         | 360            | P   |        |
| 3   | 10979.000       | 48.17          | 0.77          | 48.94          | 74.00          | 25.06       | peak     | 150         | 360            | P   |        |
| 4   | 13686.250       | 49.03          | 3.90          | 52.93          | 74.00          | 21.07       | peak     | 150         | 360            | P   |        |
| 5   | 16385.000       | 46.61          | 5.77          | 52.38          | 74.00          | 21.62       | peak     | 150         | 360            | P   |        |
| 6   | 17632.375       | 43.64          | 9.11          | 52.75          | 74.00          | 21.25       | peak     | 150         | 360            | P   |        |

2437

Vertical



Shenzhen CTL Testing Technology Co., Ltd  
Tel: +86-755-89486194

**Radiated Emission Measurement**

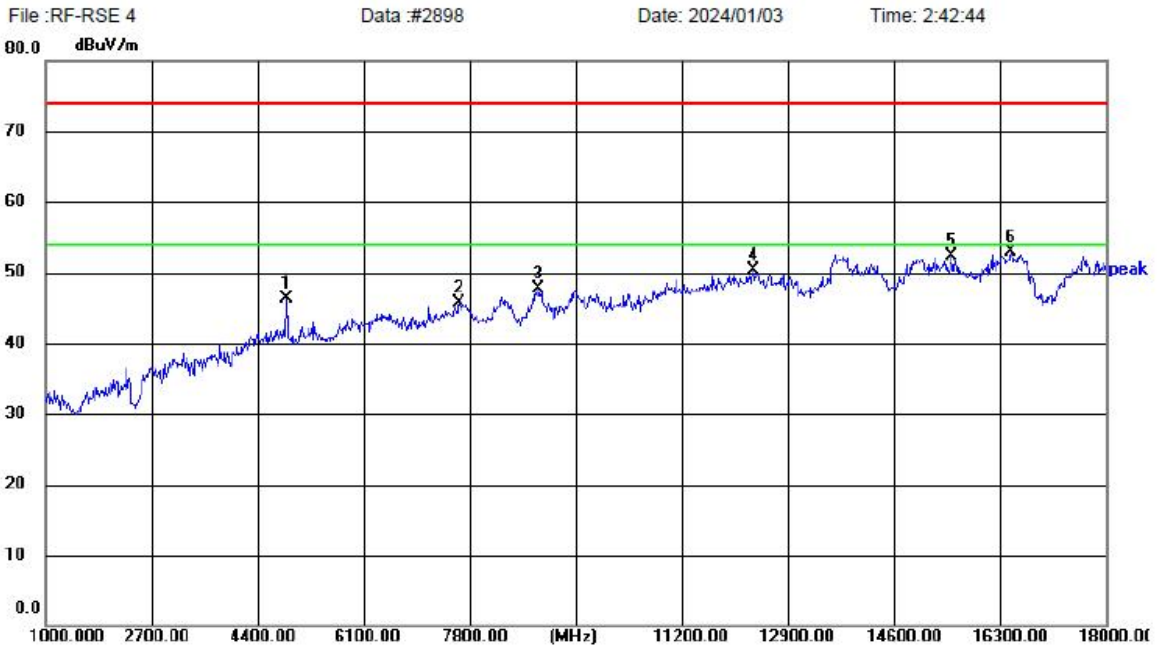

Site LAB Chamber 2      Polarization: **Vertical**      Temperature: 25(C)  
 Limit: FCC Part15 RE-Class C\_Above 1GHz\_PK      Power:      Humidity: 50 %  
 EUT:      Distance: 3m  
 M/N: Q1062LT22A  
 Mode: WIFI2.4G 2437MHz TX  
 Note: Shenzhen RoadRover Technology Co., Ltd

| No. | Frequency (MHz) | Reading (dBuV) | Factor (dB/m) | Level (dBuV/m) | Limit (dBuV/m) | Margin (dB) | Detector | Height (cm) | Azimuth (deg.) | P/F | Remark |
|-----|-----------------|----------------|---------------|----------------|----------------|-------------|----------|-------------|----------------|-----|--------|
| 1   | 4873.875        | 54.31          | -7.97         | 46.34          | 74.00          | 27.66       | peak     | 150         | 0              | P   |        |
| 2   | 7632.125        | 48.70          | -2.93         | 45.77          | 74.00          | 28.23       | peak     | 150         | 0              | P   |        |
| 3   | 8917.750        | 48.26          | -0.49         | 47.77          | 74.00          | 26.23       | peak     | 150         | 0              | P   |        |
| 4   | 12351.750       | 48.02          | 2.20          | 50.22          | 74.00          | 23.78       | peak     | 150         | 0              | P   |        |
| 5   | 15532.875       | 48.43          | 3.88          | 52.31          | 74.00          | 21.69       | peak     | 150         | 0              | P   |        |
| 6   | 16470.000       | 46.88          | 6.07          | 52.95          | 74.00          | 21.05       | peak     | 150         | 0              | P   |        |

2462

Horizontal



Shenzhen CTL Testing Technology Co., Ltd  
Tel: +86-755-89486194

**Radiated Emission Measurement**

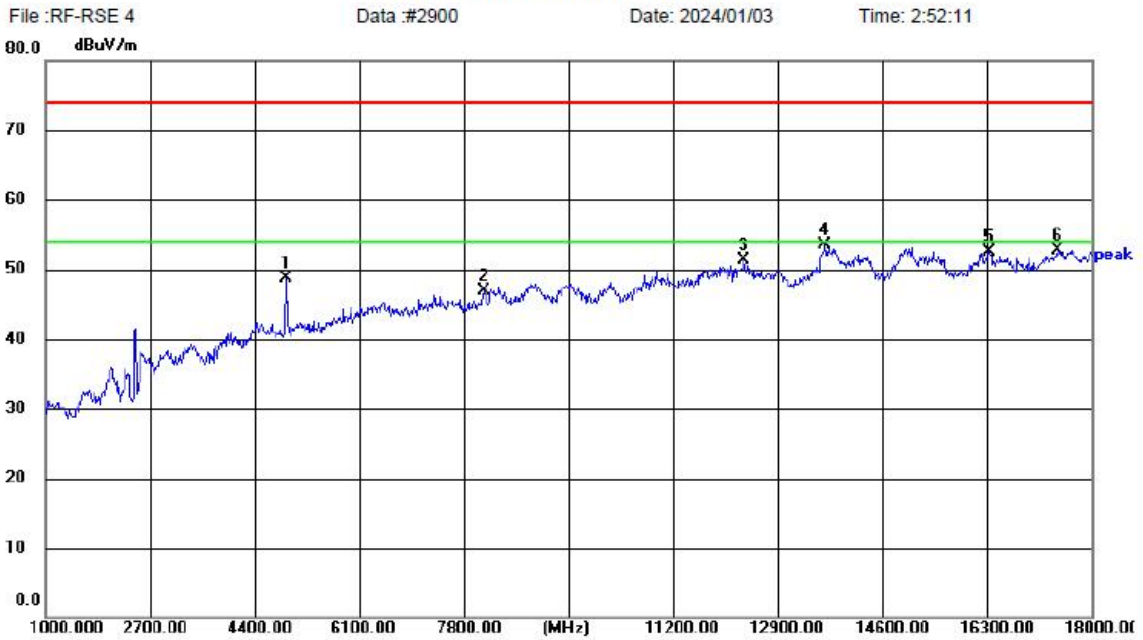

Site LAB Chamber 2      Polarization: *Horizontal*      Temperature: 25(C)  
 Limit: FCC Part15 RE-Class C\_Above 1GHz\_PK      Power:      Humidity: 50 %  
 EUT:      Distance: 3m  
 M/N: Q1062LT22A  
 Mode: WIFI2.4G 2462MHz TX  
 Note: Shenzhen RoadRover Technology Co., Ltd

| No. | Frequency (MHz) | Reading (dBuV) | Factor (dB/m) | Level (dBuV/m) | Limit (dBuV/m) | Margin (dB) | Detector | Height (cm) | Azimuth (deg.) | P/F | Remark |
|-----|-----------------|----------------|---------------|----------------|----------------|-------------|----------|-------------|----------------|-----|--------|
| 1   | 4924.875        | 56.54          | -7.89         | 48.65          | 74.00          | 25.35       | peak     | 150         | 0              | P   |        |
| 2   | 8137.875        | 49.41          | -2.60         | 46.81          | 74.00          | 27.19       | peak     | 150         | 0              | P   |        |
| 3   | 12343.250       | 49.09          | 2.19          | 51.28          | 74.00          | 22.72       | peak     | 150         | 0              | P   |        |
| 4   | 13675.625       | 49.62          | 3.91          | 53.53          | 74.00          | 20.47       | peak     | 150         | 0              | P   |        |
| 5   | 16342.500       | 46.84          | 5.64          | 52.48          | 74.00          | 21.52       | peak     | 150         | 0              | P   |        |
| 6   | 17449.625       | 43.76          | 8.96          | 52.72          | 74.00          | 21.28       | peak     | 150         | 0              | P   |        |

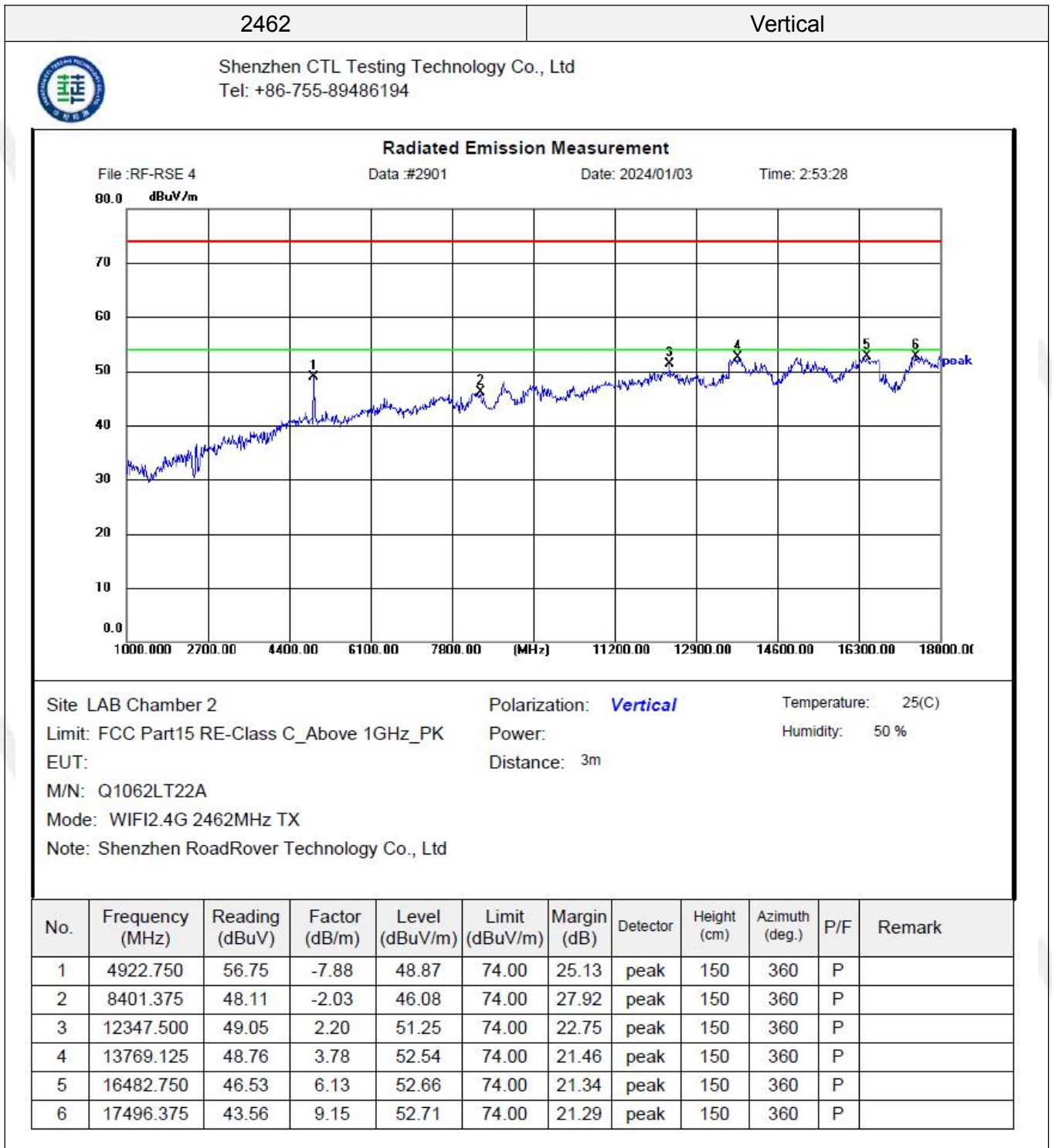

REMARKS:

1. Emission level (dBuV/m) =Raw Value (dBuV)+Correction Factor (dB/m)
2. Correction Factor (dB/m) = Antenna Factor (dB/m)+Cable Factor (dB)-Pre-amplifier Factor
3. Margin value = Limit value- Emission level.
4. -- Mean the PK detector measured value is below average limit.
5. RBW1MHz VBW3MHz Peak detector is for PK value; RBW 1MHz VBW10Hz Peak detector is for AV value.
6. Other emissions are attenuated 20dB below the limits from 9 kHz to 30MHz, so it does not recorded in report.
7. 18GHz-26GHz not recorded for no spurious point have a margin of less than 6 dB with respect to the limits.



**Results of Band Edges Test (Radiated)**

Note: 802.11b/802.11g/802.11n (H20) /802.11n (H40) all have been tested, only worse case 802.11b is reported.

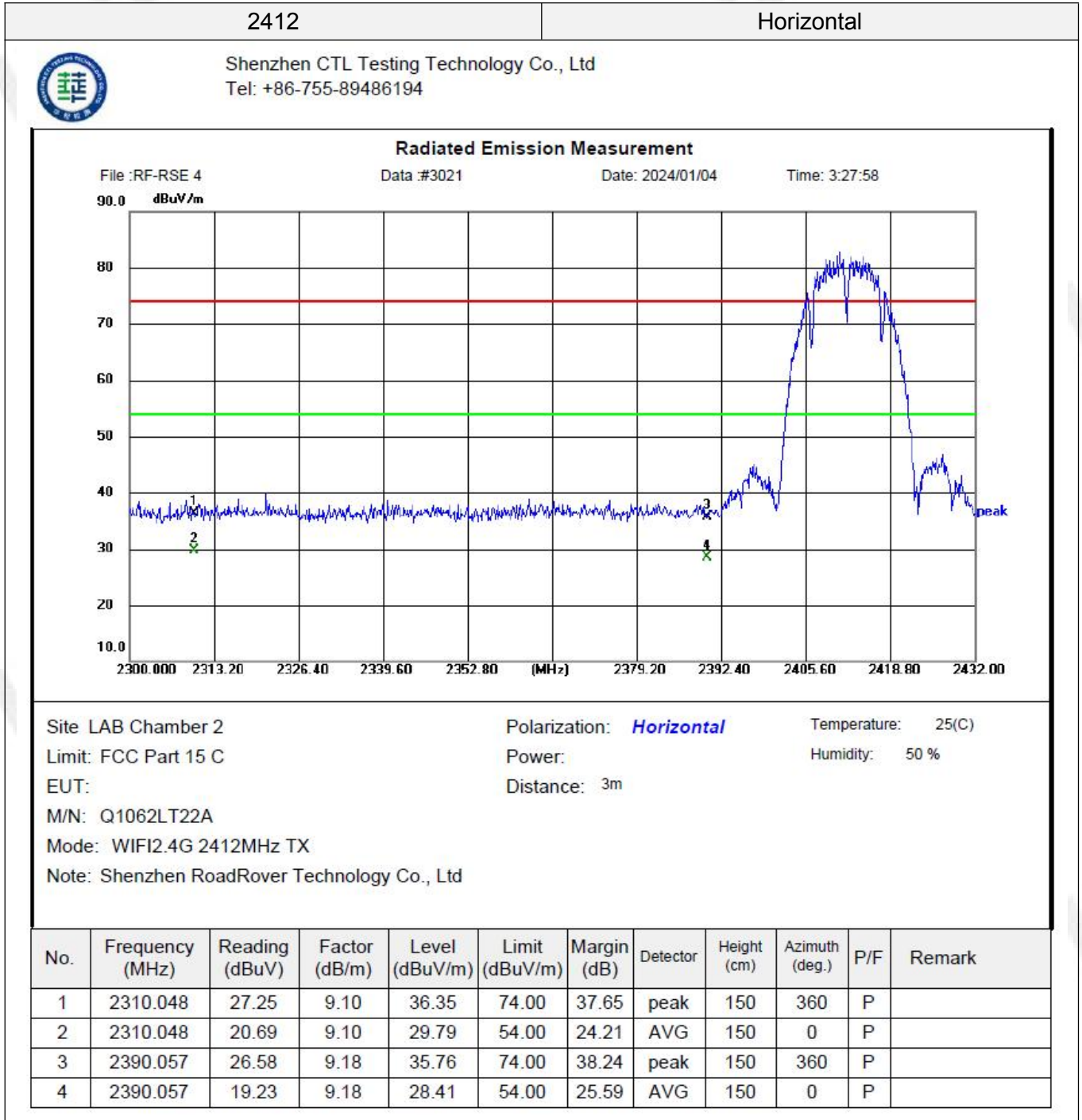

2412

Vertical



Shenzhen CTL Testing Technology Co., Ltd  
Tel: +86-755-89486194

**Radiated Emission Measurement**

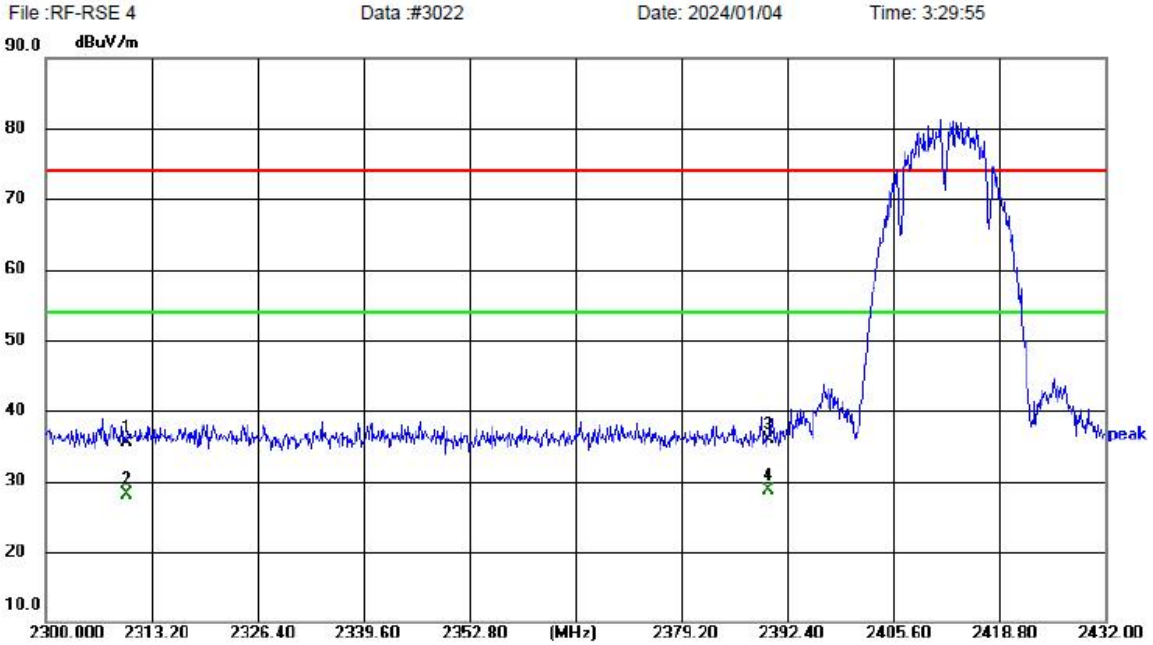

Site: LAB Chamber 2  
Limit: FCC Part 15 C  
EUT:  
M/N: Q1062LT22A  
Mode: WIFI2.4G 2412MHz TX  
Note: Shenzhen RoadRover Technology Co., Ltd

Polarization: **Vertical**  
Power:  
Distance: 3m

Temperature: 25(C)  
Humidity: 50 %

| No. | Frequency (MHz) | Reading (dBuV) | Factor (dB/m) | Level (dBuV/m) | Limit (dBuV/m) | Margin (dB) | Detector | Height (cm) | Azimuth (deg.) | P/F | Remark |
|-----|-----------------|----------------|---------------|----------------|----------------|-------------|----------|-------------|----------------|-----|--------|
| 1   | 2310.048        | 26.35          | 9.10          | 35.45          | 74.00          | 38.55       | peak     | 150         | 360            | P   |        |
| 2   | 2310.048        | 19.04          | 9.10          | 28.14          | 54.00          | 25.86       | AVG      | 150         | 0              | P   |        |
| 3   | 2390.106        | 26.80          | 9.18          | 35.98          | 74.00          | 38.02       | peak     | 150         | 360            | P   |        |
| 4   | 2390.106        | 19.60          | 9.18          | 28.78          | 54.00          | 25.22       | AVG      | 150         | 0              | P   |        |

2462

Horizontal



Shenzhen CTL Testing Technology Co., Ltd  
Tel: +86-755-89486194

**Radiated Emission Measurement**

File :RF-RSE 4      Data :#3023      Date: 2024/01/04      Time: 3:39:01



Site LAB Chamber 2      Polarization: **Horizontal**      Temperature: 25(C)  
 Limit: FCC Part 15 C      Power:      Humidity: 50 %  
 EUT:      Distance: 3m  
 M/N: Q1062LT22A  
 Mode: WIFI2.4G 2462MHz TX  
 Note: Shenzhen RoadRover Technology Co., Ltd

| No. | Frequency (MHz) | Reading (dBUV) | Factor (dB/m) | Level (dBUV/m) | Limit (dBUV/m) | Margin (dB) | Detector | Height (cm) | Azimuth (deg.) | P/F | Remark |
|-----|-----------------|----------------|---------------|----------------|----------------|-------------|----------|-------------|----------------|-----|--------|
| 1   | 2483.523        | 27.33          | 9.35          | 36.68          | 74.00          | 37.32       | peak     | 150         | 360            | P   |        |
| 2   | 2483.523        | 20.43          | 9.35          | 29.78          | 54.00          | 24.22       | AVG      | 150         | 0              | P   |        |
| 3   | 2500.030        | 27.39          | 9.42          | 36.81          | 74.00          | 37.19       | peak     | 150         | 360            | P   |        |
| 4   | 2500.030        | 20.10          | 9.42          | 29.52          | 54.00          | 24.48       | AVG      | 150         | 0              | P   |        |

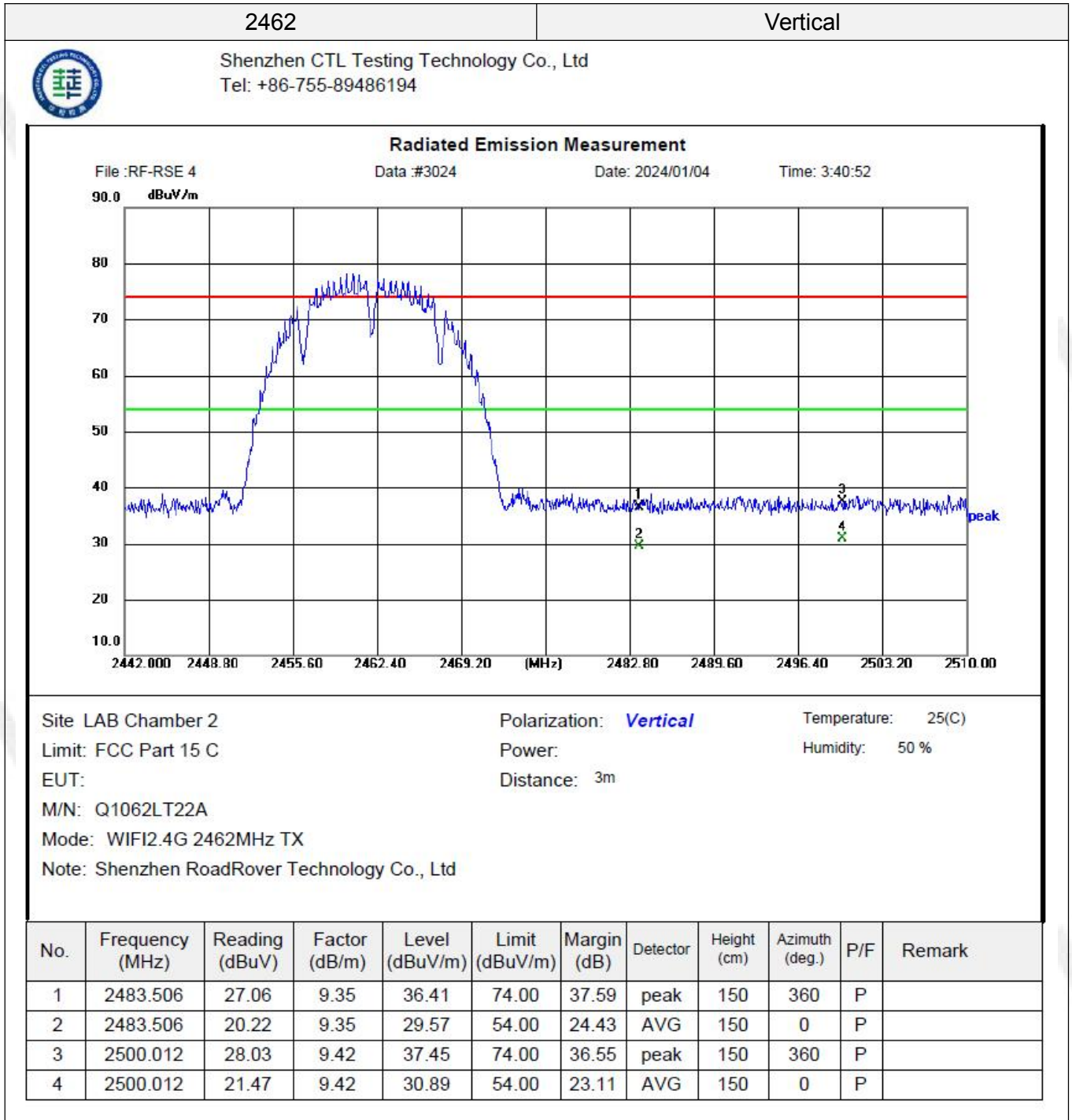

REMARKS:

1. Emission level (dBUV/m) =Raw Value (dBUV)+Correction Factor (dB/m)
2. Correction Factor (dB/m) = Antenna Factor (dB/m)+Cable Factor (dB)-Pre-amplifier Factor
3. Margin value = Limit value- Emission level.
4. PK detector measurement value is lower than the average limit. Therefore, there is no need to test AV detector measurements.
5. RBW1MHz VBW3MHz Peak detector is for PK value; RBW 1MHz VBW10Hz Peak detector is for AV value.
6. For fundamental frequency, RBW 3MHz VBW 3MHz Peak detector is for PK Value; RMS detector is for AV value.
7. Other emissions are attenuated 20dB below the limits from 9kHz to 30MHz, so it does not recorded in report.
8. 18GHz-26GHz not recorded for no spurious point have a margin of less than 6 dB with respect to the limits.

### 3.3. Maximum Conducted Output Power

#### Limit

The Maximum Peak Output Power Measurement is 30dBm.

#### Test Procedure

Remove the antenna from the EUT and then connect a low loss RF cable from the antenna port to the spectrum.

#### Test Configuration

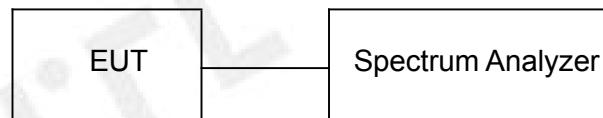

#### Test Results

Raw data reference to Section 2 of document No.CTL2311242081-WF03\_WIFI\_2.4G\_Appendix.

### 3.4. Power Spectral Density

#### Limit

For digitally modulated systems, the power spectral density conducted from the intentional radiator to the antenna shall not be greater than 8 dBm in any 3 kHz band during any time interval of continuous transmission.

#### Test Procedure

1. Use this procedure when the maximum conducted output power in the fundamental emission is used to demonstrate compliance.
2. Set the RBW  $\geq$  3 kHz.
3. Set the VBW  $\geq$  3 $\times$  RBW.
4. Set the span to 1.5 times the DTS channel bandwidth.
5. Detector = Average.
6. Trace mode = max hold.
7. Allow trace to fully stabilize.
8. Use the peak marker function to determine the maximum power level.
9. If measured value exceeds limit, reduce RBW (no less than 3 kHz) and repeat.
10. The resulting PSD level must be 8dBm.

#### Test Configuration



#### Test Results

Raw data reference to Section 3 of document No.CTL2311242081-WF03\_WIFI\_2.4G\_Appendix.

### 3.5. 6dB Bandwidth

#### Limit

For digital modulation systems, the minimum 6 dB bandwidth shall be at least 500 kHz

#### Test Procedure

The transmitter output was connected to the spectrum analyzer through an attenuator. The bandwidth of the fundamental frequency was measured by spectrum analyzer with 100 KHz RBW and 300 KHz VBW. The 6dB bandwidth is defined as the total spectrum the power of which is higher than peak power minus 6dB.

#### Test Configuration



#### Test Results

Raw data reference to Section 1 of document No.CTL2311242081-WF03\_WIFI\_2.4G\_Appendix.

### 3.6. Out-of-band Emissions

#### Limit

In any 100 kHz bandwidth outside the frequency band in which the spread spectrum or digitally modulated intentional radiator is operating, the radio frequency power that is produced by the intentional radiator shall be at least 20 dB below that in the 100 kHz bandwidth within the band that contains the highest level of the desired power, based on either an RF conducted or a radiated measurement, provided the transmitter demonstrates compliance with the peak conducted power limits. If the transmitter complies with the conducted power limits based on the use of RMS averaging over a time interval, as permitted under paragraph (b)(3) of this section, the attenuation required under this paragraph shall be 30 dB instead of 20 dB. Attenuation below the general limits specified in §15.209(a) is not required.

#### Test Procedure

Connect the transmitter output to spectrum analyzer using a low loss RF cable, and set the spectrum analyzer to RBW=100 kHz, VBW= 300 kHz, peak detector , and max hold. Measurements utilizing these setting are made of the in-band reference level, bandedge and out-of-band emissions.

#### Test Configuration



#### Test Results

Raw data reference to Section 4 of document No.CTL2311242081-WF03\_WIFI\_2.4G\_Appendix.



### 3.7. Antenna Requirement

#### Standard Applicable

For intentional device, according to FCC 47 CFR Section 15.203:

An intentional radiator shall be designed to ensure that no antenna other than that furnished by the responsible party shall be used with the device. The use of a permanently attached antenna or of an antenna that uses a unique coupling to the intentional radiator, the manufacturer may design the unit so that a broken antenna can be replaced by the user, but the use of a standard antenna jack or electrical connector is prohibited

#### **FCC CFR Title 47 Part 15 Subpart C Section 15.247(b) (4):**

(4) The conducted output power limit specified in paragraph (b) of this section is based on the use of antennas with directional gains that do not exceed 6 dBi. Except as shown in paragraph (c) of this section, if transmitting antennas of directional gain greater than 6 dBi are used, the conducted output power from the intentional radiator shall be reduced below the stated values in paragraphs (b)(1), (b)(2), and (b)(3) of this section, as appropriate, by the amount in dB that the directional gain of the antenna exceeds 6 dBi.

#### **Test Result:**

The maximum gain of Antenna was 1.50dBi.

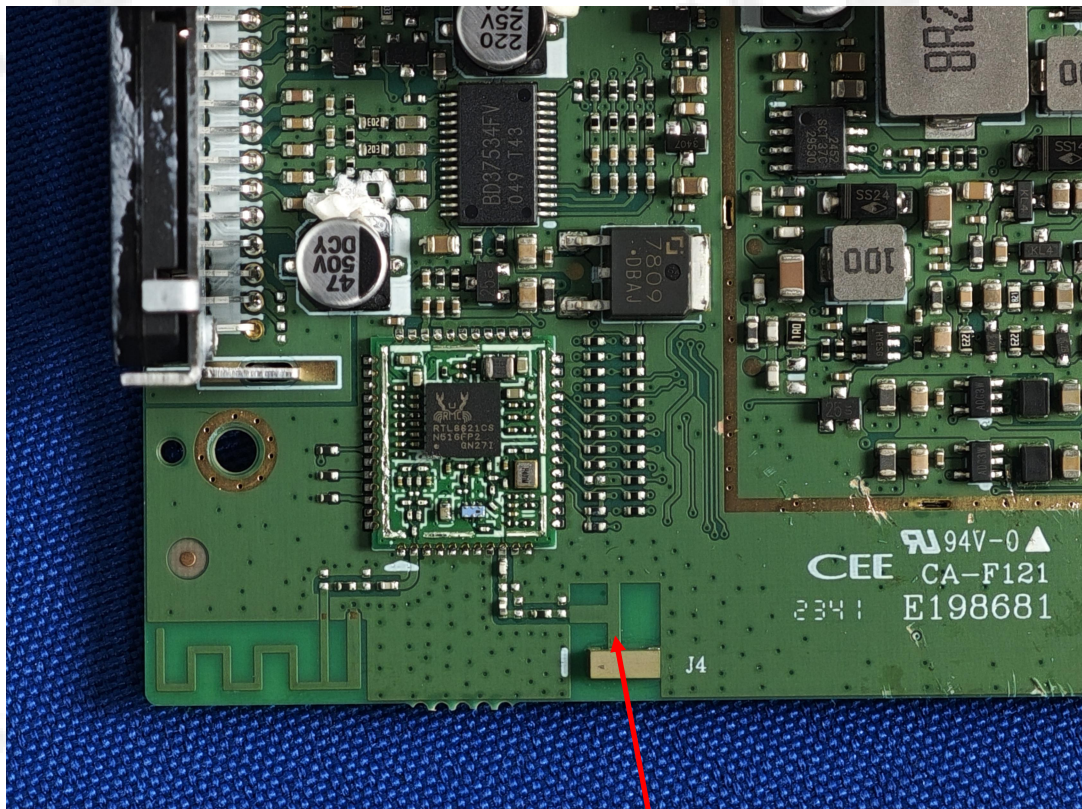

2.4G WIFI Antenna

### 4. Test Setup Photos of the EUT

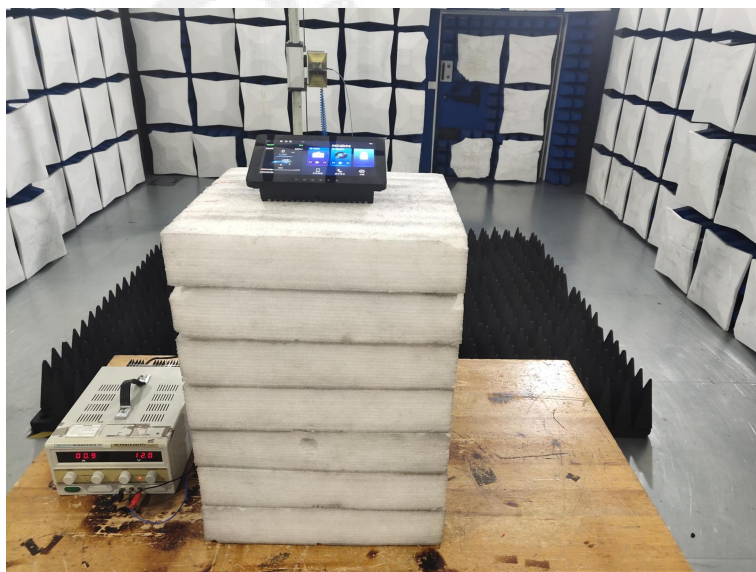
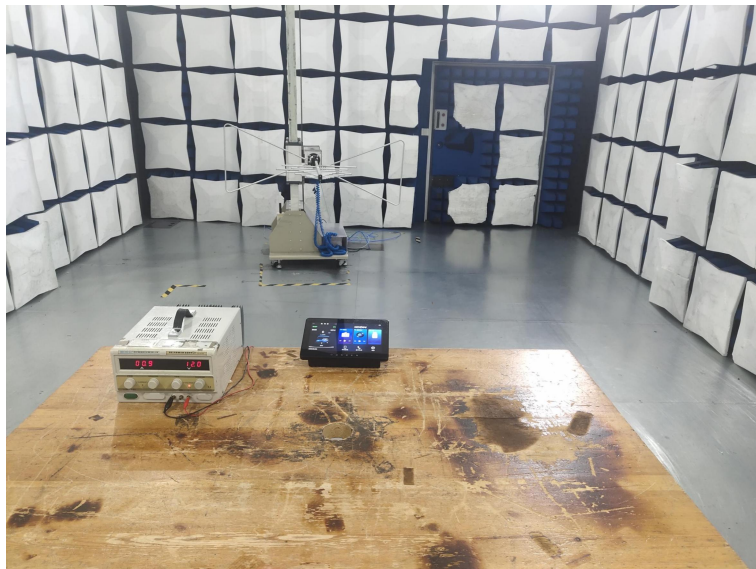
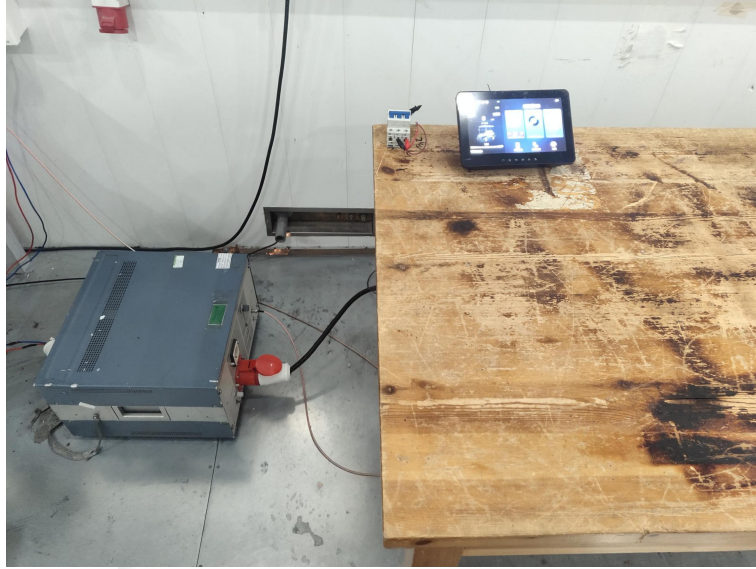

## 5. Photos of the EUT

Reference to the test report No. CTL2311242081-WF01

\*\*\*\*\* End of Report \*\*\*\*\*