

# APPROVAL SHEET

## **RFECA Series – RoHS Compliance**

CERAMIC ANTENNA

## **Halogens Free Product**

2.4 GHz ISM Band Working Frequency

## **RFECA3216060AM9FNH**

\*Contents in this sheet are subject to change without prior notice.

566-1, Ko-Shi Road , Yang-Mei, Tao-Yuan, 32668, Taiwan, China  
Tel: +886-3-475-8711  
Fax: +886-3-475-7130  
E-mail: shchen@passivecomponent.com

## FEATURES

1. Surface Mounted Devices with a small dimension of 3.2 X 1.6 X 0.6 mm<sup>3</sup> meet future miniaturization trend.
2. LTCC process.
3. High stability in Temperature / Humidity Change.
4. Superb performance to place on the middle of PCB edge and excellent peak/ average gain observed by field test application.

## APPLICATIONS

1. ISM Band 2.4GHz applications.
2. Bluetooth..

## CONSTRUCTION

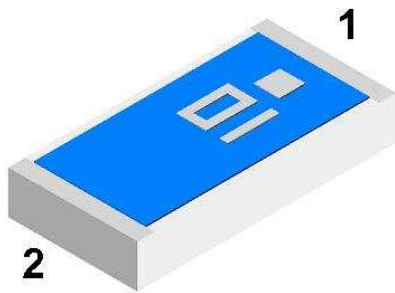

| PIN | Connection         |
|-----|--------------------|
| 1   | Feeding            |
| 2   | Soldering terminal |

## DIMENSIONS

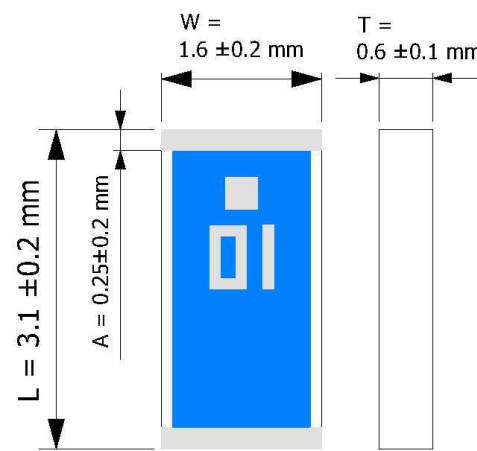
| Figure  | Symbol | Dimension (mm) |
|---|--------|----------------|
|  | L      | 3.10 ± 0.20    |
|   | W      | 1.60 ± 0.20    |
|   | T      | 0.60 ± 0.10    |
|   | A      | 0.25 ± 0.20    |

**SOLDER LAND PATTERN DESIGN**

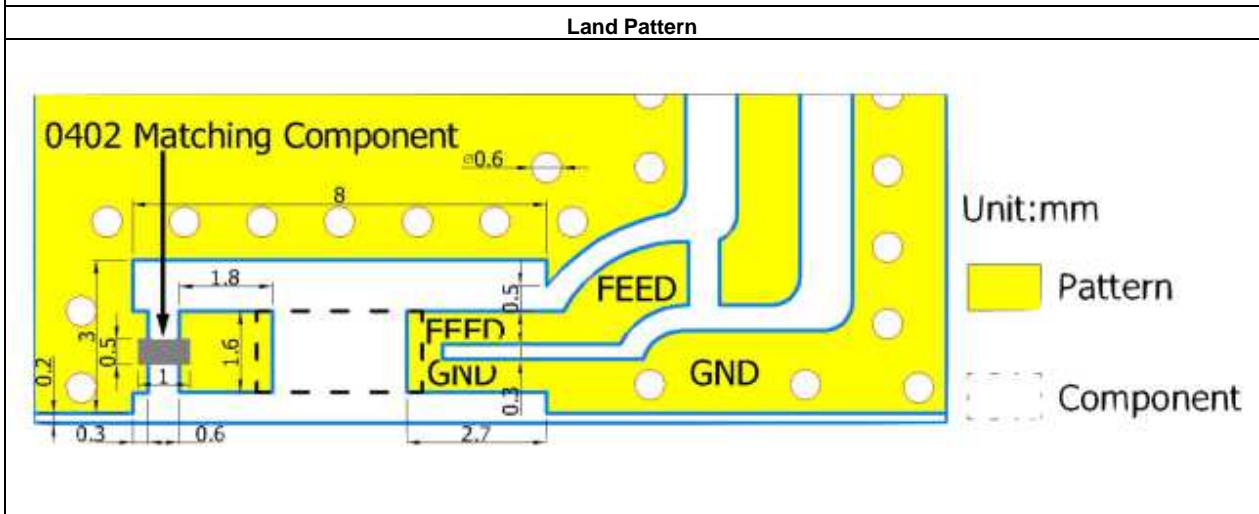
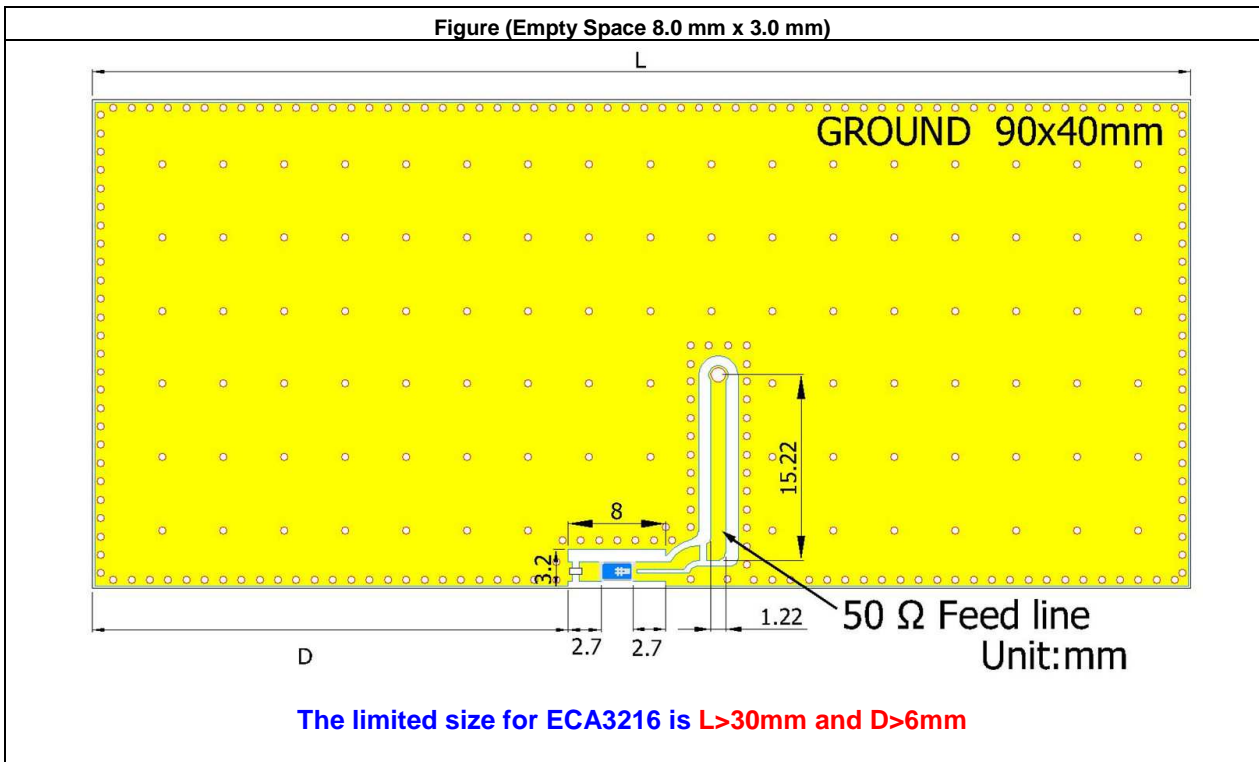

**TYPE 1 ELECTRONIC CHARACTERISTICS**

| Item                    | Specification             |
|-------------------------|---------------------------|
| Working Frequency Range | 2.4GHz~2.4835GHz (Note-1) |
| Gain                    | 2 dBi (Typical)           |
| VSWR                    | 2.1 max.                  |
| Polarization            | Linear                    |
| Azimuth Beamwidth       | Omni-directional          |
| Impedance               | 50Ω                       |

\*Note 1. Central Frequency should be defined after customers' application approval.

**Antenna on Test Board ( Thickness 0.8mm)**

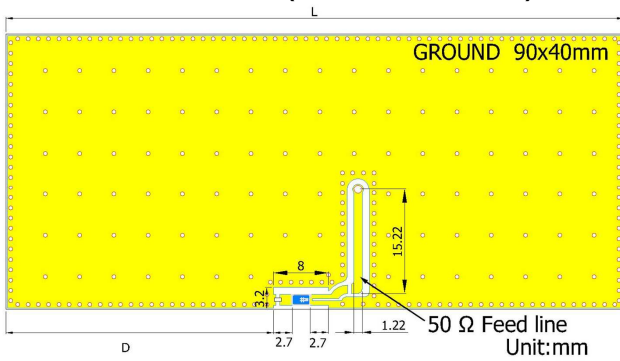

**Antenna S11 on Test Board**

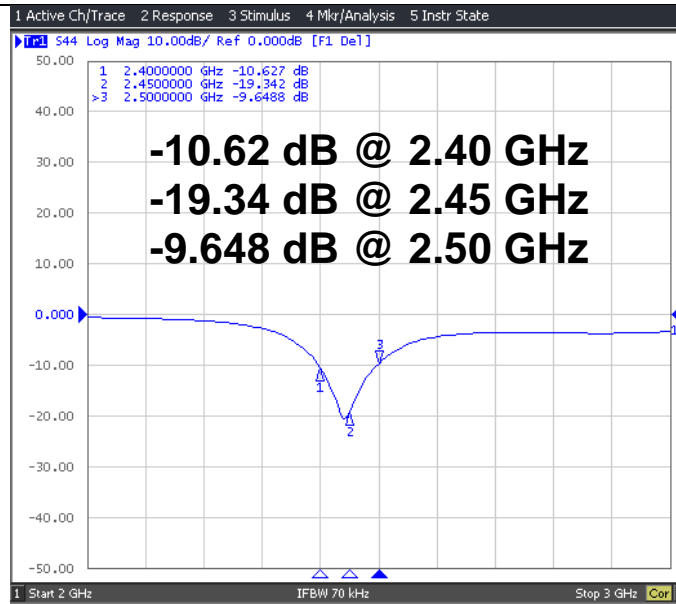

**Antenna VSWR on Test Board**

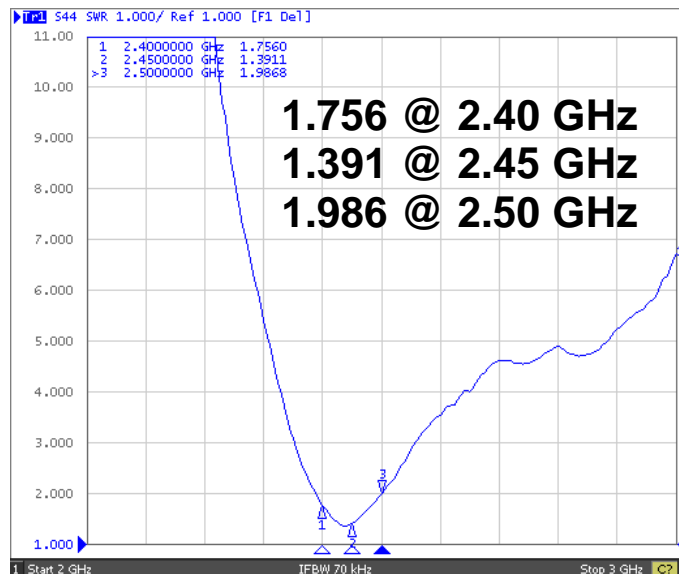

**RADIATION PATTERN**

Radiation Pattern and Gain were dependent on measurement board design. The specification of RFECA3216060A1T antenna was measured based on the PCB size and installation position as shown in the below figure Test Board.

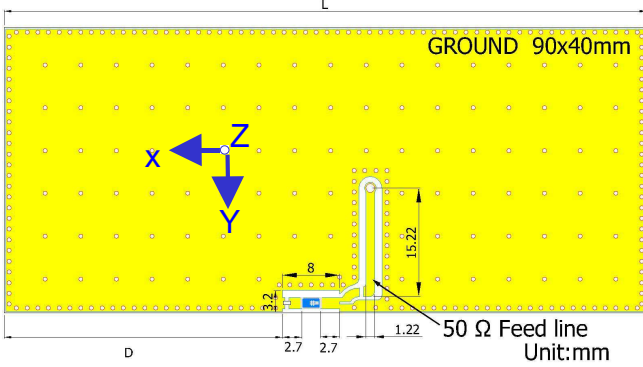

|  | Vertical  | Horizontal   |
|--|---|--|
| <b>Y - Z Plane</b><br><br>Average Gain= -1.511 dBi | <p>Peak Gain = -2.15 dBi<br/>Average Gain = -3.84 dBi</p> | <p>Peak Gain= -1.82 dBi<br/>Average Gain=-5.33 dBi</p> |
| <b>X - Z Plane</b><br><br>Average Gain= -0.571 dBi | <p>Peak Gain= 1.02 dBi<br/>Average Gain= -2.68 dBi</p>    | <p>Peak Gain= 0.36 dBi<br/>Average Gain= -4.72 dBi</p> |
| <b>X - Y Plane</b><br><br>Average Gain= -1.166 dBi | <p>Peak Gain= -8.74 dBi<br/>Average Gain= -13.63dBi</p>   | <p>Peak Gain= 2.64dBi<br/>Average Gain=-1.42 dBi</p>   |

## RELIABILITY TEST

| Test item  | Test condition / Test method   | Specification  |
|--|--|--|
| Solderability<br>JIS C 0050-4.6<br>JESD22-B102D                            | *Solder bath temperature : $235 \pm 5^{\circ}\text{C}$<br>*Immersion time : $2 \pm 0.5$ sec<br>Solder : Sn3Ag0.5Cu for lead-free   | At least 95% of a surface of each terminal electrode must be covered by fresh solder.  |
| Leaching<br>(Resistance to dissolution of metallization)<br>IEC 60068-2-58 | *Solder bath temperature : $260 \pm 5^{\circ}\text{C}$<br>*Leaching immersion time : $30 \pm 0.5$ sec<br>Solder : SN63A  | Loss of metallization on the edges of each electrode shall not exceed 25%.   |
| Resistance to soldering heat<br>JIS C 0050-5.4                             | *Preheating temperature : $120\sim 150^{\circ}\text{C}$ ,<br>1 minute.<br>*Solder temperature : $270\pm 5^{\circ}\text{C}$<br>*Immersion time : $10\pm 1$ sec<br>Solder : Sn3Ag0.5Cu for lead-free<br>Measurement to be made after keeping at room temperature for $24\pm 2$ hrs | No mechanical damage.<br>Electrical specification shall satisfy the descriptions in electrical characteristics under the operational temperature range within $-40\sim 85^{\circ}\text{C}$ .<br>Loss of metallization on the edges of each electrode shall not exceed 25%. |
| Drop Test<br>JIS C 0044<br>Customer's specification.                       | *Height : 75 cm<br>*Test Surface : Rigid surface of concrete or steel.<br>*Times : 6 surfaces for each units ; 2 times for each side.  | No mechanical damage.<br>Electrical specification shall satisfy the descriptions in electrical characteristics under the operational temperature range within $-40\sim 85^{\circ}\text{C}$ .   |
| Vibration<br>JIS C 0040  | *Frequency : 10Hz~55Hz~10Hz(1min)<br>*Total amplitude : 1.5mm<br>*Test times : 6hrs.(Two hrs each in three mutually perpendicular directions)  | No mechanical damage.<br>Electrical specification shall satisfy the descriptions in electrical characteristics under the operational temperature range within $-40\sim 85^{\circ}\text{C}$ .   |
| Adhesive Strength of Termination<br>JIS C 0051- 7.4.3                      | *Pressurizing force :<br>5N( $\leq 0603$ ) ; 10N( $>0603$ )<br>*Test time : $10\pm 1$ sec  | No remarkable damage or removal of the termination.  |

|   |  |   |
|---|--|---|
| Bending test<br>JIS C 0051- 7.4.1             | The middle part of substrate shall be pressurized by means of the pressurizing rod at a rate of about 1 mm/s per second until the deflection becomes 1mm/s and then pressure shall be maintained for 5±1 sec.<br>Measurement to be made after keeping at room temperature for 24±2 hours | No mechanical damage.<br>Electrical specification shall satisfy the descriptions in electrical characteristics under the operational temperature range within -40 ~ 85°C. |
| Temperature cycle<br>JIS C 0025               | 1. 30±3 minutes at -40°C±3°C,<br>2. 10~15 minutes at room temperature,<br>3. 30±3 minutes at +85°C±3°C,<br>4. 10~15 minutes at room temperature,<br>Total 100 continuous cycles<br>Measurement to be made after keeping at room temperature for 24±2 hrs                                 | No mechanical damage.<br>Electrical specification shall satisfy the descriptions in electrical characteristics under the operational temperature range within -40 ~ 85°C. |
| High temperature<br>JIS C 0021                | *Temperature : 85°C±2°C<br>*Test duration : 1000+24/-0 hours<br>Measurement to be made after keeping at room temperature for 24±2 hrs  | No mechanical damage.<br>Electrical specification shall satisfy the descriptions in electrical characteristics under the operational temperature range within -40 ~ 85°C. |
| Humidity<br>(steady conditions)<br>JIS C 0022 | *Humidity : 90% to 95% R.H.<br>*Temperature : 40±2°C<br>*Time : 1000+24/-0 hrs.<br>Measurement to be made after keeping at room temperature for 24±2 hrs<br>※ 500hrs measuring the first data then 1000hrs data  | No mechanical damage.<br>Electrical specification shall satisfy the descriptions in electrical characteristics under the operational temperature range within -40 ~ 85°C. |
| Low temperature<br>JIS C 0020                 | *Temperature : -40°C±2°C<br>*Test duration : 1000+24/-0 hours<br>Measurement to be made after keeping at room temperature for 24±2 hrs   | No mechanical damage.<br>Electrical specification shall satisfy the descriptions in electrical characteristics under the operational temperature range within -40 ~ 85°C. |

**SOLDERING CONDITION**

Typical examples of soldering processes that provide reliable joints without any damage are given in Fig 2

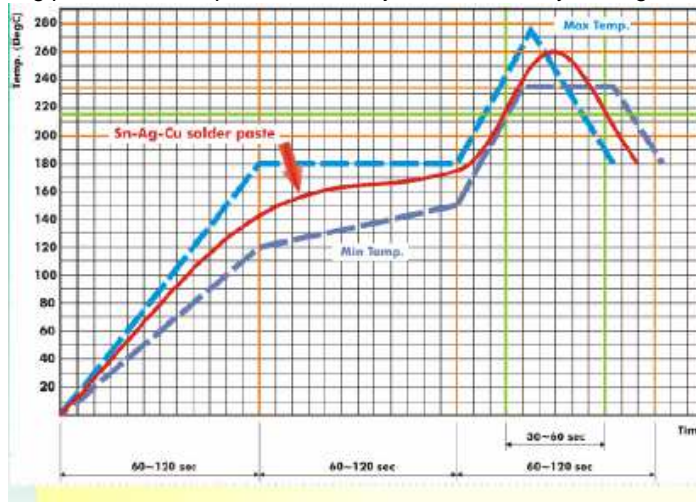

Fig 2. Infrared soldering profile

**ORDERING CODE**

|                            |   |  |  |  |                                     |                              |
|----------------------------|---|--|--|--|-------------------------------------|------------------------------|
| <b>RF</b>                  | <b>ECA</b>                              | <b>321606</b>  | <b>0</b>   | <b>A</b>                                     | <b>1</b>                            | <b>T</b>                     |
| <b>Walsin</b><br>RF device | <b>Product code</b><br>ANT :<br>Antenna | <b>Dimension code</b><br>Per 2 digits of<br>Length, Width,<br>Thickness :<br>e.g. :<br>321606 =<br>Length 32,<br>Width 16,<br>Thickness 06 | <b>Unit of dimension</b><br>0 : 0.1 mm<br>1 : 1.0 mm | <b>Application</b><br>A : 2.4GHz ISM<br>Band | <b>Specification</b><br>Design Code | <b>Packing</b><br>T : Reeled |

Minimum Ordering Quantity: 2000 pcs per reel.

**PACKAGING**

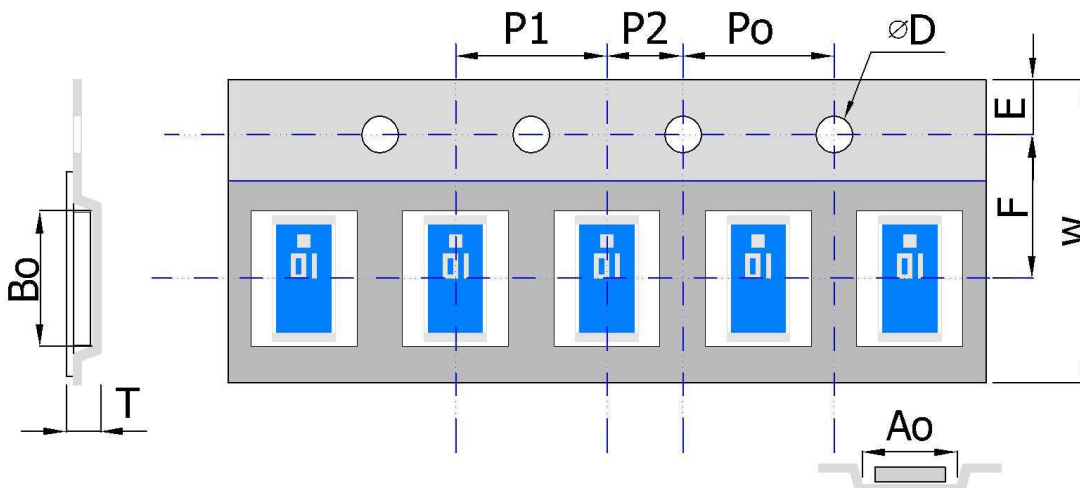

Plastic Tape specifications (unit :mm)

|                |             |             |             |             |             |
|----------------|-------------|-------------|-------------|-------------|-------------|
| Index          | Ao          | Bo          | ΦD          | T           | W           |
| Dimension (mm) | 1.85 ± 0.10 | 3.45 ± 0.10 | 1.55 ± 0.05 | 0.75 ± 0.10 | 8.00 ± 0.30 |
| Index          | E           | F           | Po          | P1          | P2          |
| Dimension (mm) | 1.75 ± 0.10 | 3.50 ± 0.05 | 4.00 ± 0.10 | 4.00 ± 0.10 | 2.00 ± 0.10 |



## Reel dimensions

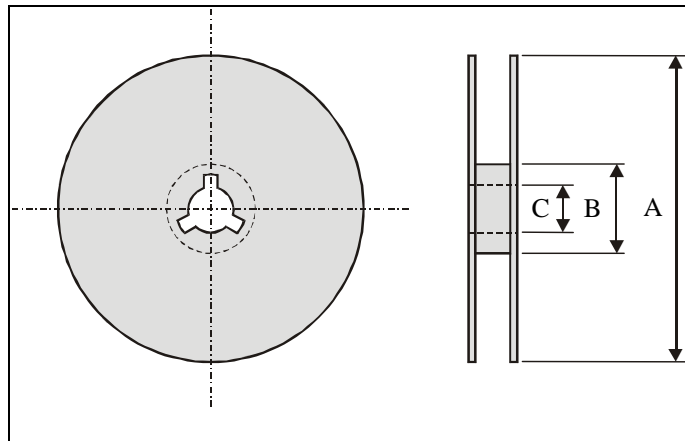

| Index          | A      | B     | C     |
|----------------|--------|-------|-------|
| Dimension (mm) | Φ178.0 | Φ60.0 | Φ13.0 |

Taping Quantity:2000 pieces per 7" reel

## CAUTION OF HANDLING

## Limitation of Applications

Please contact us before using our products for the applications listed below which require especially high reliability for the prevention of defects, which might directly cause damage to the third party's life, body or property.

- (1) Aircraft equipment
- (2) Aerospace equipment
- (3) Undersea equipment
- (4) Medical equipment
- (5) Disaster prevention / crime prevention equipment
- (6) Traffic signal equipment
- (7) Transportation equipment (vehicles, trains, ships, etc.)
- (8) Applications of similar complexity and /or reliability requirements to the applications listed in the above.

## Storage condition

- (1) Products should be used in 6 months from the day of WAL SIN outgoing inspection, which can be confirmed.
- (2) Storage environment condition.
  - Products should be storage in the warehouse on the following conditions.
  - Temperature : -10 to +40°C
  - Humidity : 30 to 70% relative humidity
  - Don't keep products in corrosive gases such as sulfur. Chlorine gas or acid or it may cause oxidization of electrode, resulting in poor solderability.
  - Products should be storage on the palette for the prevention of the influence from humidity, dust and son on.
  - Products should be storage in the warehouse without heat shock, vibration, direct sunlight and so on.
  - Products should be storage under the airtight packaged condition.