

Antenna test Report

Client: Shenzhen Yipincheng Technology Co., Ltd

Project name:C2

RF:JiangYa

Date:2024-04-23

Version:V0.1

Laboratory testing environment and equipment



Test items	Test equipment
S11、 S12 、 VSWR 、 LOSS	network analyzer E5071B、 E5062A
Efficiency、 Gain 3D Radiation Pattern	Satimo SG16darkroom、 GP7*4*3 darkroom、 E5071B
TRP、 TIS	Satimo SG16darkroom、 GP7*4*3 darkroom、 8960 、 CMW500、 MT8820C、 E4438C、

Type of complete machine	Adult bracelet				
		Frequency band information	antenna form	Matching	Gain (dBi)
Antenna type and frequency band information	antenna	2400-2500MHz	IFA	NA	2.00
Antenna material	FPC cable				

Suggested Matching Circuit

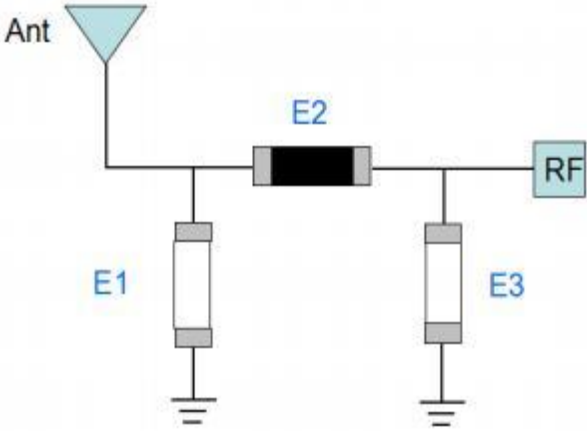

	Element	Value	Description of attached drawings	
main	E1(0201)			
	E2(0201)	0Ω		
	E3(0201)			



Physical picture

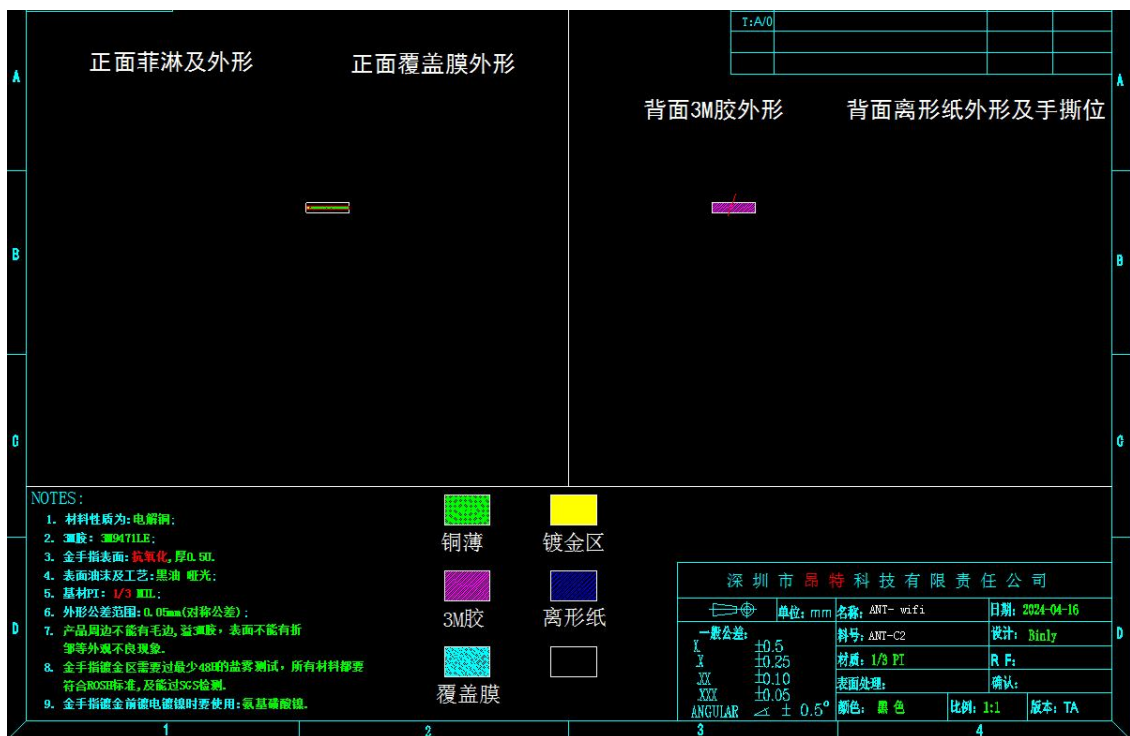
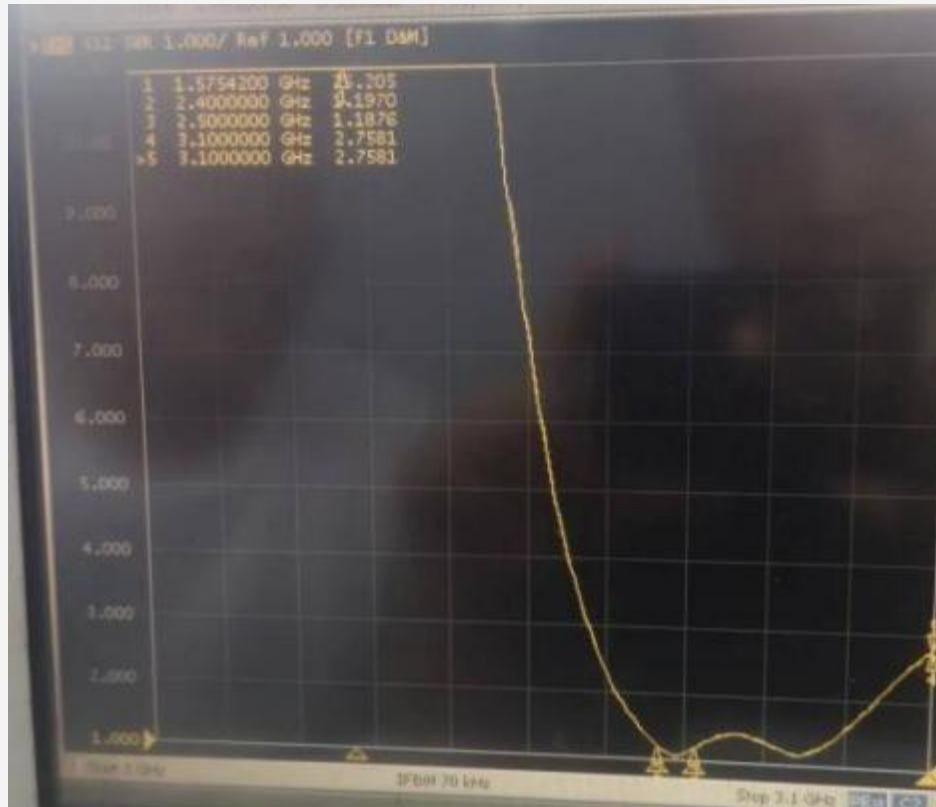

Figure antenna structure

S11



S11



S11

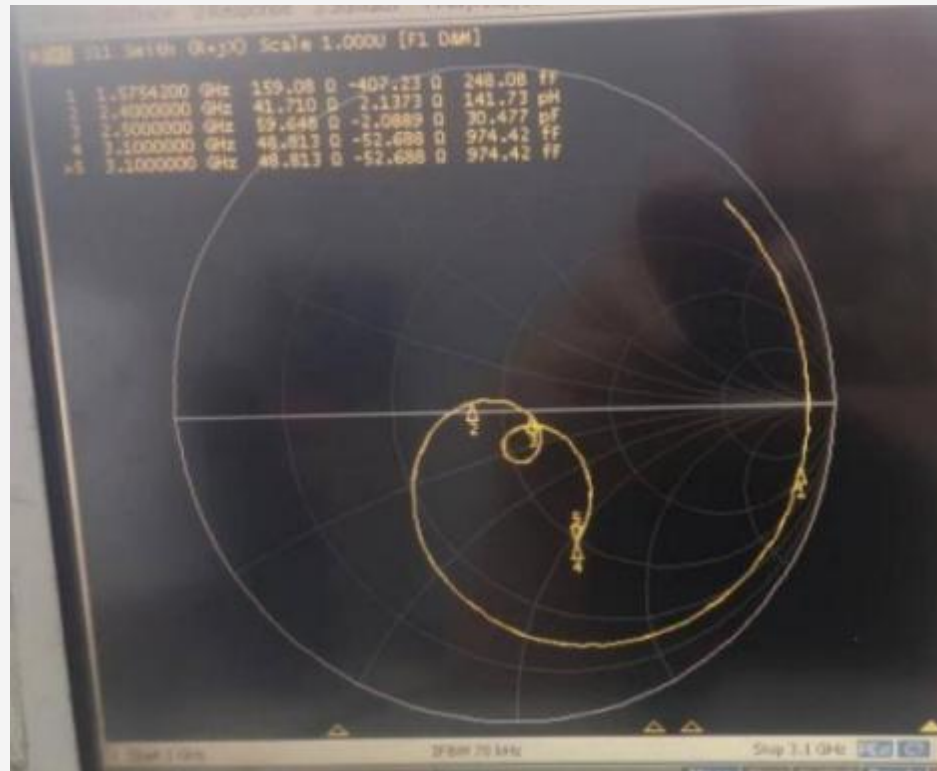

Passive Efficiency

Passive Test For 2.4G								
Freq (MHz)	Effi (%)	Effi (dB)	Gain (dBi)	Gain (dBd)	UHS (%)	DHS (%)	Max (dB)	Min (dB)
2400	50.46	-2.65	1.25	2.08	30.707	23.561	5.11	-18.61
2410	54.21	-2.54	1.88	2.14	31.739	23.952	5.32	-18.53
2420	55.44	-2.7	1.6	2.63	30.577	23.098	4.96	-17.64
2430	56.07	-2.86	1.27	1.89	29.454	22.269	4.65	-18.21
2440	56.34	-2.73	1.53	2.14	30.462	22.931	4.77	-17.31
2450	53.19	-2.58	1.5	2.05	31.279	23.941	4.82	-17.31
2460	50.76	-2.58	1.19	3.07	31.452	23.802	4.81	-18.8
2470	48.3	-2.81	1.78	3.07	29.794	22.532	4.6	-18.46
2480	53.98	-2.8	2	2.19	29.931	22.509	4.59	-19.79
2490	52.04	-2.56	1.89	2.24	31.637	23.837	4.83	-18.61
2500	48.13	-2.69	1.73	2.05	30.567	23.237	4.62	-17.4

Radiation Pattern

2.4GHZ

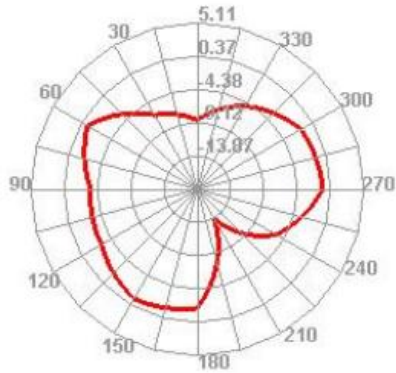

X-Y 面

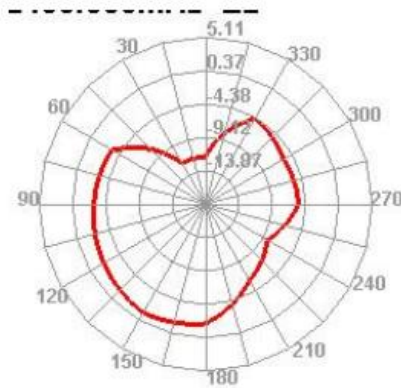

X-Z 面

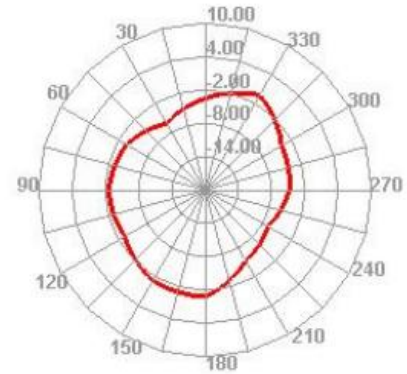

Y-Z 面

Contact Information

RF : JiangYa

Tel : 13047098007

E-mail : samuel720@163.com

supplieraddress: 601, building E, 8th Seongbuk District, Shangxue Science & Technology, xinxue community, Bantian Street, Longgang District, Shenzhen, China