



FCC TEST REPORT

FCC ID: 2BFG4-M51HV

Product	:	MDVR
Model Name	:	M51HV.TGWE-A-A
Additional model	:	Refer to page 4
Brand	:	CITOPS
Report No.	:	PTC24022912301E-FC02
Prepared for		
Shenzhen Citops Systems Co., Ltd.		
11/F. Block A. Delux Sci-Tech Park, No.5 Guanle Road, Longhua New District, Shenzhen, China		
Prepared by		
Precise Testing & Certification Co., Ltd		
Building 1, No. 6, Tongxin Road, Dongcheng Street, Dongguan, Guangdong, China		



1 Test Result Certification

Applicant's name : Shenzhen Citops Systems Co., Ltd.
Address : 11/F. Block A. Delux Sci-Tech Park, No.5 Guanle Road, Longhua New District, Shenzhen, China
Manufacture's name : Shenzhen Citops Systems Co., Ltd.
Address : 11/F. Block A. Delux Sci-Tech Park, No.5 Guanle Road, Longhua New District, Shenzhen, China
Product name : MDVR
Model Name : M51HV.TGWE-A-A
Additional model : Refer to page 4
Standards : 47 CFR FCC Part 22 Subpart H, 47 CFR FCC Part 24 Subpart E, 47 CFR FCC Part 27, ANSI C63.26-2015, KDB 971168 D01 Power Meas License Digital Systems v03r01
Test Date : Mar. 07, 2024 to May. 10, 2024
Date of Issue : May. 22, 2024
Test Result : Pass

This device described above has been tested by PTC, and the test results show that the equipment under test (EUT) is in compliance with the FCC requirements. And it is applicable only to the tested sample identified in the report.

This report shall not be reproduced except in full, without the written approval of PTC, this document may be altered or revised by PTC, personal only, and shall be noted in the revision of the document.

Test Engineer:

A handwritten signature in black ink, appearing to read 'Jack Zhou'.

Jack Zhou / Engineer

Technical Manager:

A handwritten signature in black ink, appearing to read 'Simon Pu'.

Simon Pu / Manager



TABLE OF CONTENTS

1	Test Result Certification	2
1.	General Description Of Eut	4
2.	Facilities And Accreditations	6
2.1.	TEST FACILITY	6
2.2.	DESCRIPTION OF TEST CHANNELS AND TEST MODES	7
2.3.	EQUIPMENT MODIFICATIONS	8
3.	Summary Of Test Requirements And Results	9
4.	Measurement Instruments	11
5.	Effective (Isotropic) Radiated Power and Conducted Output Power .	13
5.1.	CONDUCTED OUTPUT POWER	13
5.2.	EFFECTIVE (ISOTROPIC) RADIATED POWER	13
6.	Spurious Emission (Conducted and Radiated)	17
6.1.	MEASUREMENT RESULT (PRE-MEASUREMENT)	17
7.	Occupied Bandwidth and Emission Bandwidth	45
8.	Band Edge	80
9.	Frequency Stability	103
9.1.	MEASUREMENT RESULT (WORST)	104
15	APPENDIX I -- TEST SETUP PHOTOGRAPH	106
16	APPENDIX II -- EUT PHOTOGRAPH	107



1. General Description Of Eut

Product Name:	MDVR	
Model Name:	M51HV.TGWE-A-A	
Additional model:	M16Hv.DGWE1-A,M20Cv.DGWE-A,M32Hv.TGWE1-A,M51Hv.DGWE1-A, M52Hv.DGWE1-A,M71Hv.SGWE-A,M91Hv.DGWE-A,M15Hv.SGNE-A, M16Hv.DGWE2-A,M20Cv.DGWE-A-A,M32Hv.TGWE2-A,M51Hv.DGWE2-A,M52Hv.D GWE2-A,M16Hv.DGNE1-A-A,M18Ev.DGWE-A,M32Hv.TGWE1-A-A,M51Hv.DGWE1- A-A,M52Hv.DGWE1-A-A, M16Hv.DGWE1-A-A, M18Ev.DGWE-A-A,M32Hv.TGWE2-A-A,M51Hv.DGWE2-A-A, M52Hv.DGWE2-A-A, 20Ev.SGWC-A, 18Ev.SGWC-A	
Hardware version:	M125.02	
Software version:	M51Hv-APP-V010153.	
Frequency Bands:	WCDMA: <input checked="" type="checkbox"/> WCDMA Band II <input checked="" type="checkbox"/> WCDMA Band IV <input checked="" type="checkbox"/> WCDMA Band V	
Operation Frequency Range:	WCADM band II:	1852.4 MHz -1907.6 MHz
	WCADM band IV:	1712.4 MHz -1752.6 MHz
	WCADM band V:	826.4 MHz - 846.6 MHz
Antenna Type:	External Antenna	
Antenna gain:	WCADM band II:	-3.46dBi
	WCADM band IV:	-0.35dBi
	WCADM band V:	-1.19dBi
Type of Modulation:	<input checked="" type="checkbox"/> RMC(QPSK) <input checked="" type="checkbox"/> HSUPA(QPSK) <input checked="" type="checkbox"/> HSDPA(QPSK,16QAM)	
Power supply:	Input: 12V/24V 20W Output: 12V 12W	
Max power:	See Table 2.1	
Extreme Vol. Limits:	DC 10.8V to 13.2V (Normal: DC 12V)	
Test sample No.	PTC24022912301E-1/2, PTC24022912301E-2/2.	



Table 2.1 The Basic Technical Specification for Working BAND(S).

OPERATION BAND(S)	Power Class	Mod.	Max EIRP/ERP (dBm)
WCDMA Band II	Class 3	QPSK	19.91
WCDMA Band IV	Class 3	QPSK	22.87
WCDMA Band V	Class 3	QPSK	20.66



Report No.: PTC24022912301E-FC02

2. Facilities And Accreditations

2.1. Test Facility

Precise Testing & Certification Co., Ltd

Address: Building 1, No. 6, Tongxin Road, Dongcheng Street, Dongguan, Guangdong, China

FCC Registration Number: 790290

A2LA Certificate No.: 4408.01

IC Registration Number: 12191A



2.2. Description Of Test Channels And Test Modes

Test channels:

WCDMA Band II			
Test Channel	BW(MHz)	UL Channel	Frequency(MHz)
Low Range	5	9262	1852.4
Mid Range	5	9400	1880
High Range	5	9538	1907.6

WCDMA Band IV			
Test Channel	BW(MHz)	UL Channel	Frequency(MHz)
Low Range	5	1312	1712.4
Mid Range	5	1413	1732.6
High Range	5	1513	1752.6

WCDMA Band V			
Test Channel	BW(MHz)	UL Channel	Frequency(MHz)
Low Range	5	4132	826.4
Mid Range	5	4182	836.4
High Range	5	4233	846.6

Note 1: The worst condition was recorded in the test report if no other modes test data.



2.3. Equipment Modifications

Not available for this EUT intended for grant.



3. Summary Of Test Requirements And Results

WCDMA Band II :

Test Item	FCC Rule No.	Requirements	Judgement
Effective (Isotropic) Radiated Power	§2.1046, §24.232(c)	EIRP ≤ 2W(33dBm)	Pass
Bandwidth	§2.1049	OBW: No limit. EBW: No limit.	Pass
Band Edges	§2.1051, §24.238	≤-13 dBm/1%*EBW, in 1 MHz bands immediately outside and adjacent to the frequency block.	Pass
Spurious Emission at Antenna Terminals	§2.1051, §24.238	FCC: ≤-13 dBm/100 kHz, from 9 kHz to 10th harmonics but outside authorized operating frequency ranges.	Pass
Field Strength of Spurious Radiation	§2.1053, §24.238(a)	-13dBm/1MHz	Pass
Frequency Stability	§2.1055, §24.235	the fundamental emission stays within the authorized frequency block. ≤±2.5ppm.	Pass
Peak to average ratio	§2.1046 §24.232	≤ 13dB	Pass

WCDMA Band IV:

Test Item	FCC Rule No.	Requirements	Judgement
Effective (Isotropic) Radiated Power	§2.1046, §2.913(a)	EIRP ≤ 1W(30dBm)	Pass
Occupied Bandwidth	§2.1049	OBW: No limit.	Pass
Emission Bandwidth	§2.1049	EBW: No limit.	Pass
Band Edges Compliance	§2.1051 §27.53(h)	≤-13 dBm/1%*EBW, in 1 MHz bands immediately outside and adjacent to the frequency block.	Pass
Spurious Emission at Antenna Terminals	§2.1051, §27.53(h)	FCC: ≤-13 dBm/100 kHz, from 9 kHz to 10th harmonics but outside authorized operating frequency ranges.	Pass
Field Strength of Spurious Radiation	§2.1053, §22.917	FCC: ≤-13 dBm/100 kHz.	Pass
Frequency Stability	§2.1055, §27.54	the fundamental emissions stay within the authorized bands of operation. (2.5ppm)	Pass
Peak to average ratio	§2.1046 §27.50(d)	≤ 13dB	Pass



WCDMA Band V:

Test Item	FCC Rule No.	Requirements	Judgement
Effective (Isotropic) Radiated Power	§2.1046, §2.913(a)	EIRP \leq 7W(38.5dBm)	Pass
Occupied Bandwidth	§2.1049	OBW: No limit.	Pass
Emission Bandwidth	22.917(b)	EBW: No limit.	Pass
Band Edges Compliance	§2.1051 §22.917(a)	\leq -13 dBm/1%*EBW, in 1 MHz bands immediately outside and adjacent to the frequency block.	Pass
Spurious Emission at Antenna Terminals	§2.1051, §22.917	FCC: \leq -13 dBm/100 kHz, from 9 kHz to 10th harmonics but outside authorized operating frequency ranges.	Pass
Field Strength of Spurious Radiation	§2.1053, §22.917	FCC: \leq -13 dBm/100 kHz.	Pass
Frequency Stability	§2.1055, §22.355	the fundamental emissions stay within the authorized bands of operation. (2.5ppm)	Pass



4. Measurement Instruments

RF Conducted Test

Name of Equipment	Manufacturer	Model	Serial No.	Characteristics	Last Calibration	Calibration Interval
MXG Signal Analyzer	Agilent	N9020A	SER MY5111038	10Hz-30GHz	Aug.17, 2023	1 Year
Coaxial Cable	CDS	79254	46107086	10Hz-30GHz	Aug.17, 2023	1 Year
Power Meter	Anritsu	ML2495A	0949003	300MHz-40GHz	Aug.17, 2023	1 Year
Power Sensor	Anritsu	MA2411B	0917017	300MHz-40GHz	Aug.17, 2023	1 Year
Signal Analyzer 40GHZ	Rohde&Schwarz	FSV40	101456	10Hz-40GHz	Aug.17, 2023	1 Year
Wireless Communication Tester	Rohde&Schwarz	CMW500	134930	/	Aug.17, 2023	1 year

Remark: The temporary antenna connector is soldered on the PCB board in order to perform conducted tests and this temporary antenna connector is listed in the equipment list.

Name of Equipment	Manufacturer	Model	Serial No.	Characteristics	Last Calibration	Calibration Interval
EMI Test Receiver	Rohde&Schwarz	ESCI7	101671	9KHz-7GHz	Aug. 17,2023	1 Year
Loop Antenna	Schwarzbeck	FMZB 1519B	192	9 KHz -30MHz	Aug. 17,2023	1 Year
Bilog Antenna	SCHWARZBECK	VULB9160	9160-3355	25MHz-2GHz	Aug. 17,2023	1 Year
Preamplifier (low frequency)	SCHWARZBECK	BBV 9475	9745-0013	1MHz-1GHz	Mar. 23,2024	1 Year
Cable	Schwarzbeck	PLF-100	549489	9KHz-3GHz	Aug. 17,2023	1 Year
Spectrum Analyzer	Rohde&Schwarz	FSV40	6625-01-588-5515	9KHz-40GHz	Aug.17, 2023	1 Year
Horn Antenna	SCHWARZBECK	9120D	9120D-1246	1GHz-18GHz	Aug. 17, 2023	1 Year
Power Amplifier	ZHINAN	ZN3380C	15002	1GHz-26.5GHz	Aug. 17, 2023	1 Year
Horn Antenna	SCHWARZBECK	BBHA 9170	9170-1066	15GHz-40GHz	Jul. 19, 2023	1 Year



Report No.: PTC24022912301E-FC02

Amplifier	SCHWARZBEC K	BBV 9721	9721-205	18GHz-40GH z	Jul. 19, 2023	1 Year
Cable	H+S	CBL-26	N/A	1GHz-26.5GH z	Aug. 17,2023	1 Year
RF Cable	R&S	R204	R21X	1GHz-40GHz	Aug. 17,2023	1 Year
MXG Vector Signal Generator	Agilent	N5182A	MY49060455	-	Aug. 17,2023	1 Year
ESG Series Analog signal generator	Agilent	E4421B	GB40051240	-	Aug. 17,2023	1 Year



5. Effective (Isotropic) Radiated Power and Conducted Output Power

5.1. Conducted Output Power

Measurement Procedure: FCC KDB 971168 D01 V03r01

The transmitter output was connected to a calibrated coaxial cable, attenuator and power meter, the other end of which was connected to a Base Station Simulator. The Base Station Simulator was set to force the EUT to its maximum power setting. The power output at the transmitter antenna port was determined by adding the value of the cable insertion loss to the power reading. The tests were performed at three frequencies (low channel, middle channel and high channel) and on the highest power levels, which can be setup on the transmitters.

5.2. Effective (Isotropic) Radiated Power

Measurement Procedure: FCC KDB 971168 D01 V03r01 ; C63.26 (2015).

Calculate power in dBm by the following formula:

$ERP \text{ (dBm)} = \text{Conducted Power (dBm)} + \text{antenna gain (dBd)}$

$EIRP \text{ (dBm)} = \text{Conducted Power (dBm)} + \text{antenna gain (dBi)}$

$EIRP = ERP + 2.15 \text{ dB}$



Test result:

WCDMA Band II and Band IV and BandV RMC:

Band	Channel	Conducted Power(dBm)	ERP/EIRP(dBm)	Limit(dBm)	Verdict
Band2	9262	22.68	19.22	33	PASS
Band2	9400	23.01	19.55	33	PASS
Band2	9538	23.37	19.91	33	PASS
Band4	1312	22.35	22.00	30	PASS
Band4	1413	23.22	22.87	30	PASS
Band4	1513	22.86	22.51	30	PASS
Band5	4132	23.91	20.57	38.5	PASS
Band5	4182	23.93	20.59	38.5	PASS
Band5	4233	24.00	20.66	38.5	PASS

WCDMA Band II and Band IV and BandV HSDPA :

Band	Channel	SubTest	Conducted Power(dBm)	ERP/EIRP(dBm)	Limit(dBm)	Verdict
Band2	9262	1	21.82	18.36	33	PASS
Band2	9262	2	21.54	18.08	33	PASS
Band2	9262	3	21.52	18.06	33	PASS
Band2	9262	4	21.56	18.10	33	PASS
Band2	9400	1	22.47	19.01	33	PASS
Band2	9400	2	21.99	18.53	33	PASS
Band2	9400	3	21.94	18.48	33	PASS
Band2	9400	4	21.93	18.47	33	PASS
Band2	9538	1	21.80	18.34	33	PASS
Band2	9538	2	21.54	18.08	33	PASS
Band2	9538	3	21.69	18.23	33	PASS
Band2	9538	4	21.67	18.21	33	PASS
Band4	1312	1	21.57	21.22	30	PASS
Band4	1312	2	21.13	20.78	30	PASS
Band4	1312	3	21.12	20.77	30	PASS
Band4	1312	4	21.08	20.73	30	PASS
Band4	1413	1	22.32	21.97	30	PASS
Band4	1413	2	21.86	21.51	30	PASS
Band4	1413	3	21.86	21.51	30	PASS
Band4	1413	4	21.87	21.52	30	PASS
Band4	1513	1	22.05	21.70	30	PASS
Band4	1513	2	21.58	21.23	30	PASS
Band4	1513	3	21.65	21.30	30	PASS
Band4	1513	4	21.58	21.23	30	PASS
Band5	4132	1	22.90	19.56	38.5	PASS
Band5	4132	2	22.49	19.15	38.5	PASS
Band5	4132	3	22.36	19.02	38.5	PASS
Band5	4132	4	22.33	18.99	38.5	PASS
Band5	4182	1	22.90	19.56	38.5	PASS
Band5	4182	2	22.36	19.02	38.5	PASS
Band5	4182	3	22.38	19.04	38.5	PASS
Band5	4182	4	22.35	19.01	38.5	PASS
Band5	4233	1	22.96	19.62	38.5	PASS
Band5	4233	2	22.43	19.09	38.5	PASS
Band5	4233	3	22.44	19.10	38.5	PASS
Band5	4233	4	22.43	19.09	38.5	PASS



WCDMA Band II and Band IV and Band V HSUPA :

Band	Channel	SubTest	Conducted Power(dBm)	ERP/EIRP(dBm)	Limit(dBm)	Verdict
Band2	9262	1	21.39	17.93	33	PASS
Band2	9262	2	20.90	17.44	33	PASS
Band2	9262	3	19.98	16.52	33	PASS
Band2	9262	4	21.19	17.73	33	PASS
Band2	9262	5	21.99	18.53	33	PASS
Band2	9400	1	22.12	18.66	33	PASS
Band2	9400	2	21.41	17.95	33	PASS
Band2	9400	3	20.60	17.14	33	PASS
Band2	9400	4	21.46	18.00	33	PASS
Band2	9400	5	22.39	18.93	33	PASS
Band2	9538	1	22.00	18.54	33	PASS
Band2	9538	2	21.20	17.74	33	PASS
Band2	9538	3	20.63	17.17	33	PASS
Band2	9538	4	21.59	18.13	33	PASS
Band2	9538	5	22.33	18.87	33	PASS
Band4	1312	1	21.32	20.97	30	PASS
Band4	1312	2	20.51	20.16	30	PASS
Band4	1312	3	19.61	19.26	30	PASS
Band4	1312	4	20.39	20.04	30	PASS
Band4	1312	5	21.51	21.16	30	PASS
Band4	1413	1	21.68	21.33	30	PASS
Band4	1413	2	20.79	20.44	30	PASS
Band4	1413	3	20.51	20.16	30	PASS
Band4	1413	4	21.09	20.74	30	PASS
Band4	1413	5	22.27	21.92	30	PASS
Band4	1513	1	21.55	21.20	30	PASS
Band4	1513	2	21.07	20.72	30	PASS



Band4	1513	3	20.78	20.43	30	PASS
Band4	1513	4	21.34	20.99	30	PASS
Band4	1513	5	22.11	21.76	30	PASS
Band5	4132	1	22.05	18.71	38.5	PASS
Band5	4132	2	21.66	18.32	38.5	PASS
Band5	4132	3	20.87	17.53	38.5	PASS
Band5	4132	4	21.81	18.47	38.5	PASS
Band5	4132	5	22.99	19.65	38.5	PASS
Band5	4182	1	22.43	19.09	38.5	PASS
Band5	4182	2	21.88	18.54	38.5	PASS
Band5	4182	3	20.97	17.63	38.5	PASS
Band5	4182	4	22.02	18.68	38.5	PASS
Band5	4182	5	22.88	19.54	38.5	PASS
Band5	4233	1	22.44	19.10	38.5	PASS
Band5	4233	2	22.01	18.67	38.5	PASS
Band5	4233	3	21.79	18.45	38.5	PASS
Band5	4233	4	22.31	18.97	38.5	PASS
Band5	4233	5	22.83	19.49	38.5	PASS

Note:

For getting the EIRP (Efficient Isotropic Radiated Power), the following formula The following formula is used for calculation:

1. ERP [dBm] = Conducted Power [dBm] + Gain [dBd]

2. EIRP [dBm] = Conducted Power [dBm] + Gain [dBi]



6. Spurious Emission (Conducted and Radiated)

6.1. Measurement Result (Pre-measurement)

WCDMA BAND II:

Test Channel	BW(MHz)	UL Channel	Frequency(MHz)	Judgment
Low Range	0.2	9262	1852.4	Pass
Middle Range	0.2	9400	1880	Pass
High Range	0.2	9538	1907.6	Pass

WCDMA BAND IV:

Test Channel	BW(MHz)	UL Channel	Frequency(MHz)	Judgment
Low Range	0.2	1312	1712.4	Pass
Middle Range	0.2	1413	1732.6	Pass
High Range	0.2	1513	1752.6	Pass

WCDMA BAND V:

Test Channel	BW(MHz)	UL Channel	Frequency(MHz)	Judgment
Low Range	5	4132	826.4	Pass
Middle Range	5	4182	836.4	Pass
High Range	5	4233	846.6	Pass



Test Plot(s)
Conducted method

Test limit:

The spurious (unwanted) emission limits specified in the individual FCC rule parts applicable to licensed digital transmitters (typically referred to under the heading 'emission limits') normally apply to any and all emissions that are present outside of the authorized frequency band/block and apply to emissions in both the out-of-band and spurious domains. In some rule parts, the unwanted emission limits are specified by an emission mask that defines the applicable limit as a function of the frequency range relative to the authorized frequency block.

Typically, unwanted emissions are required by the licensed rule parts to be attenuated below the transmitter power by a factor of at least $X + 10\log(P)$ dB, where P represents the transmitter power expressed in watts and X is a specified scalar value (e.g., 43). This specification can be interpreted in one of two equivalent ways. First, the required attenuation can be construed to be relative to the mean carrier power, with the resultant of the equation $X + 10\log(P)$ being expressed in dBc (dB relative to the maximum carrier power). Alternatively, the specification can be interpreted as an absolute limit when the specified attenuation is actually subtracted from the maximum permissible transmitter power [i.e., $10\log(P) - \{X + 10\log(P)\}$], resulting in an absolute level of -X dBW [or $(-X + 30)$ dBm]. See section 4.

Test procedure:

The RF output of the transceiver was connected to a spectrum analyzer and simulator through appropriate attenuation. The resolution bandwidth of the spectrum analyzer was set at 100 kHz below 1 GHz and 1 MHz above 1 GHz. Sufficient scans were taken to show any out of band emissions up to 10th harmonics.

Conducted Emission Test-Up:

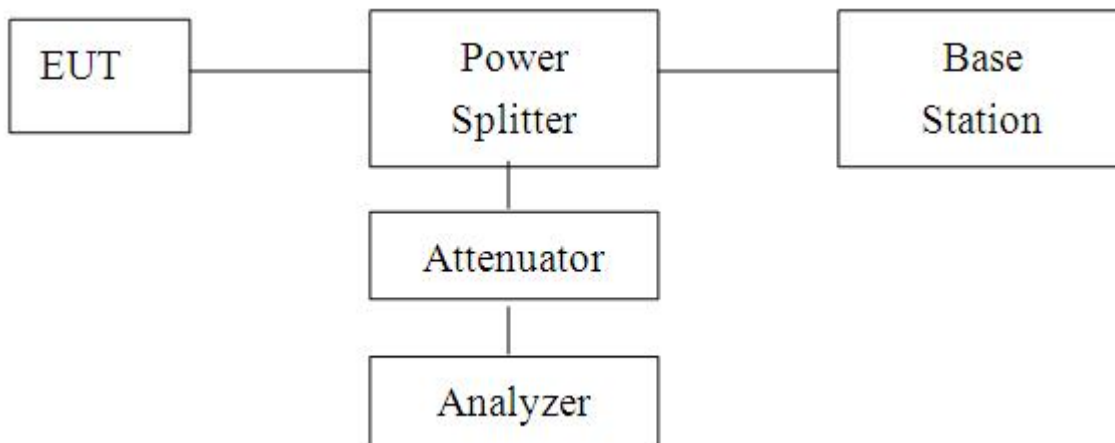



Test Result:

Band	Channel	Frequency Range (Mhz)	Frequency (dBm)	Result (dBm)	Limit (dBm)	Verdict
Band2	9262	0.009~0.15MHz	0.01	-66.21	-43	PASS
Band2	9262	0.15~30MHz	0.15	-53.41	-23	PASS
Band2	9262	30~1000MHz	998.84	-56.64	-13	PASS
Band2	9262	1000~3000MHz	2682.07	-51.94	-13	PASS
Band2	9262	3000~20000MHz	17012.53	-40.53	-13	PASS
Band2	9400	0.009~0.15MHz	0.01	-66.28	-43	PASS
Band2	9400	0.15~30MHz	0.15	-53.91	-23	PASS
Band2	9400	30~1000MHz	909.6	-57.09	-13	PASS
Band2	9400	1000~3000MHz	2673.4	-51.95	-13	PASS
Band2	9400	3000~20000MHz	17035.2	-40.48	-13	PASS
Band2	9538	0.009~0.15MHz	0.01	-65.91	-43	PASS
Band2	9538	0.15~30MHz	0.16	-53.18	-23	PASS
Band2	9538	30~1000MHz	834.1	-56.47	-13	PASS
Band2	9538	1000~3000MHz	2675	-51.93	-13	PASS
Band2	9538	3000~20000MHz	17018.77	-40.46	-13	PASS
Band4	1312	0.009~0.15MHz	0.09	-65.34	-43	PASS
Band4	1312	0.15~30MHz	3.81	-50.67	-23	PASS
Band4	1312	30~1000MHz	80.21	-56.3	-13	PASS
Band4	1312	1000~3000MHz	2670.07	-51.64	-13	PASS
Band4	1312	3000~20000MHz	17038.03	-40.43	-13	PASS
Band4	1413	0.009~0.15MHz	0.01	-65.85	-43	PASS
Band4	1413	0.15~30MHz	3.8	-48.6	-23	PASS
Band4	1413	30~1000MHz	974.17	-56.42	-13	PASS
Band4	1413	1000~3000MHz	2680.73	-51.68	-13	PASS
Band4	1413	3000~20000MHz	17040.87	-40.32	-13	PASS
Band4	1513	0.009~0.15MHz	0.09	-65.66	-43	PASS
Band4	1513	0.15~30MHz	3.83	-49.64	-23	PASS
Band4	1513	30~1000MHz	867.66	-56.82	-13	PASS
Band4	1513	1000~3000MHz	2672.4	-51.65	-13	PASS
Band4	1513	3000~20000MHz	17056.17	-40.41	-13	PASS
Band5	4132	0.009~0.15MHz	0.01	-66.04	-33	PASS
Band5	4132	0.15~30MHz	0.16	-52.7	-13	PASS
Band5	4132	30~1000MHz	555.48	-64.48	-13	PASS
Band5	4132	1000~10000MHz	3175.3	-48.13	-13	PASS
Band5	4182	0.009~0.15MHz	0.01	-66.15	-33	PASS
Band5	4182	0.15~30MHz	0.15	-52.82	-13	PASS
Band5	4182	30~1000MHz	593.34	-65.02	-13	PASS
Band5	4182	1000~10000MHz	3055.9	-48.27	-13	PASS
Band5	4233	0.009~0.15MHz	0.01	-66.13	-33	PASS
Band5	4233	0.15~30MHz	0.16	-53.42	-13	PASS
Band5	4233	30~1000MHz	973.84	-65.14	-13	PASS
Band5	4233	1000~10000MHz	3190.9	-48.08	-13	PASS

Band	Channel	SubTest	Frequency Range (Mhz)	Frequency (dBm)	Result (dBm)	Limit (dBm)	Verdict
Band2	9262	1	0.15~30MHz	0.16	-54.26	-23	PASS
Band2	9262	1	30~1000MHz	933.72	-56.14	-13	PASS
Band2	9262	1	1000~3000MHz	2673.67	-51.95	-13	PASS
Band2	9262	1	3000~20000MHz	17013.1	-40.51	-13	PASS
Band2	9262	1	0.009~0.15MHz	0.01	-64.47	-43	PASS
Band2	9262	2	3000~20000MHz	17012.53	-40.5	-13	PASS
Band2	9262	2	1000~3000MHz	2673.2	-51.88	-13	PASS
Band2	9262	2	30~1000MHz	834.94	-55.59	-13	PASS



Band2	9262	2	0.15~30MHz	0.15	-54.74	-23	PASS
Band2	9262	2	0.009~0.15MHz	0.01	-66.42	-43	PASS
Band2	9262	3	1000~3000MHz	2680.93	-51.98	-13	PASS
Band2	9262	3	0.009~0.15MHz	0.01	-67.07	-43	PASS
Band2	9262	3	30~1000MHz	804.51	-56.07	-13	PASS
Band2	9262	3	3000~20000MHz	17016.5	-40.52	-13	PASS
Band2	9262	3	0.15~30MHz	0.16	-55.01	-23	PASS
Band2	9262	4	1000~3000MHz	2678.07	-51.94	-13	PASS
Band2	9262	4	0.009~0.15MHz	0.01	-66.47	-43	PASS
Band2	9262	4	0.15~30MHz	0.15	-53.72	-23	PASS
Band2	9262	4	30~1000MHz	895.79	-55.67	-13	PASS
Band2	9262	4	3000~20000MHz	17025	-40.56	-13	PASS
Band2	9400	1	3000~20000MHz	17016.5	-40.53	-13	PASS
Band2	9400	1	1000~3000MHz	2673.2	-52.01	-13	PASS
Band2	9400	1	30~1000MHz	951.11	-55.35	-13	PASS
Band2	9400	1	0.15~30MHz	0.15	-51.85	-23	PASS
Band2	9400	1	0.009~0.15MHz	0.01	-66.39	-43	PASS
Band2	9400	2	0.15~30MHz	0.16	-54.66	-23	PASS
Band2	9400	2	30~1000MHz	835.07	-56.13	-13	PASS
Band2	9400	2	3000~20000MHz	17022.17	-40.56	-13	PASS
Band2	9400	2	0.009~0.15MHz	0.01	-66.27	-43	PASS
Band2	9400	2	1000~3000MHz	2675.87	-51.99	-13	PASS
Band2	9400	3	0.009~0.15MHz	0.01	-67.28	-43	PASS
Band2	9400	3	3000~20000MHz	17018.2	-40.53	-13	PASS
Band2	9400	3	1000~3000MHz	2676.47	-51.96	-13	PASS
Band2	9400	3	30~1000MHz	902.81	-55.99	-13	PASS
Band2	9400	3	0.15~30MHz	0.15	-51.87	-23	PASS
Band2	9400	4	0.009~0.15MHz	0.01	-66.8	-43	PASS
Band2	9400	4	0.15~30MHz	0.15	-52.7	-23	PASS
Band2	9400	4	3000~20000MHz	17010.27	-40.47	-13	PASS
Band2	9400	4	1000~3000MHz	2685.33	-51.92	-13	PASS
Band2	9400	4	30~1000MHz	178.99	-56.9	-13	PASS
Band2	9538	1	30~1000MHz	976.36	-55.81	-13	PASS
Band2	9538	1	1000~3000MHz	2677.13	-51.95	-13	PASS
Band2	9538	1	3000~20000MHz	17010.83	-40.49	-13	PASS
Band2	9538	1	0.009~0.15MHz	0.01	-66	-43	PASS
Band2	9538	1	0.15~30MHz	0.15	-53.22	-23	PASS
Band2	9538	2	3000~20000MHz	17015.93	-40.56	-13	PASS
Band2	9538	2	1000~3000MHz	2674.67	-51.93	-13	PASS
Band2	9538	2	30~1000MHz	952.34	-56.1	-13	PASS
Band2	9538	2	0.009~0.15MHz	0.01	-66.34	-43	PASS
Band2	9538	2	0.15~30MHz	0.17	-54.03	-23	PASS
Band2	9538	3	30~1000MHz	926.51	-55.83	-13	PASS
Band2	9538	3	1000~3000MHz	2681.8	-52.01	-13	PASS
Band2	9538	3	0.009~0.15MHz	0.01	-67.03	-43	PASS
Band2	9538	3	0.15~30MHz	0.15	-53.93	-23	PASS
Band2	9538	3	3000~20000MHz	17025.57	-40.55	-13	PASS
Band2	9538	4	0.009~0.15MHz	0.01	-66.28	-43	PASS
Band2	9538	4	0.15~30MHz	0.15	-53.19	-23	PASS
Band2	9538	4	30~1000MHz	922.14	-56.31	-13	PASS
Band2	9538	4	1000~3000MHz	2685.13	-51.92	-13	PASS
Band2	9538	4	3000~20000MHz	17012.53	-40.51	-13	PASS
Band4	1312	1	1000~3000MHz	2675.4	-51.69	-13	PASS
Band4	1312	1	3000~20000MHz	17042.57	-40.4	-13	PASS
Band4	1312	1	30~1000MHz	983.41	-56.87	-13	PASS
Band4	1312	1	0.15~30MHz	0.15	-52.15	-23	PASS



Band4	1312	1	0.009~0.15MHz	0.01	-65.97	-43	PASS
Band4	1312	2	3000~20000MHz	17021.6	-40.46	-13	PASS
Band4	1312	2	1000~3000MHz	2689.87	-51.77	-13	PASS
Band4	1312	2	30~1000MHz	515.87	-56.38	-13	PASS
Band4	1312	2	0.15~30MHz	3.74	-53.84	-23	PASS
Band4	1312	2	0.009~0.15MHz	0.14	-65.9	-43	PASS
Band4	1312	3	30~1000MHz	917.42	-55.78	-13	PASS
Band4	1312	3	0.15~30MHz	0.15	-53.78	-23	PASS
Band4	1312	3	1000~3000MHz	2685.33	-51.76	-13	PASS
Band4	1312	3	3000~20000MHz	17016.5	-40.5	-13	PASS
Band4	1312	3	0.009~0.15MHz	0.09	-66.84	-43	PASS
Band4	1312	4	0.009~0.15MHz	0.09	-64.22	-43	PASS
Band4	1312	4	3000~20000MHz	17014.23	-40.49	-13	PASS
Band4	1312	4	1000~3000MHz	2675.53	-51.61	-13	PASS
Band4	1312	4	30~1000MHz	925.6	-56.77	-13	PASS
Band4	1312	4	0.15~30MHz	0.16	-51.98	-23	PASS
Band4	1413	1	30~1000MHz	877.42	-56.98	-13	PASS
Band4	1413	1	0.15~30MHz	3.81	-52.04	-23	PASS
Band4	1413	1	0.009~0.15MHz	0.09	-65.47	-43	PASS
Band4	1413	1	1000~3000MHz	2677	-51.7	-13	PASS
Band4	1413	1	3000~20000MHz	17006.3	-40.57	-13	PASS
Band4	1413	2	0.009~0.15MHz	0.14	-65.53	-43	PASS
Band4	1413	2	3000~20000MHz	17010.83	-40.5	-13	PASS
Band4	1413	2	1000~3000MHz	2679.93	-51.63	-13	PASS
Band4	1413	2	30~1000MHz	940.7	-56.98	-13	PASS
Band4	1413	2	0.15~30MHz	3.79	-52.63	-23	PASS
Band4	1413	3	3000~20000MHz	17005.73	-40.54	-13	PASS
Band4	1413	3	1000~3000MHz	2675.53	-51.83	-13	PASS
Band4	1413	3	30~1000MHz	872.83	-56.89	-13	PASS
Band4	1413	3	0.15~30MHz	3.77	-51.44	-23	PASS
Band4	1413	3	0.009~0.15MHz	0.01	-64.89	-43	PASS
Band4	1413	4	0.15~30MHz	0.15	-53.31	-23	PASS
Band4	1413	4	3000~20000MHz	17037.47	-40.47	-13	PASS
Band4	1413	4	30~1000MHz	80.31	-56.13	-13	PASS
Band4	1413	4	0.009~0.15MHz	0.09	-65.42	-43	PASS
Band4	1413	4	1000~3000MHz	2676.6	-51.85	-13	PASS
Band4	1513	1	0.009~0.15MHz	0.14	-65.68	-43	PASS
Band4	1513	1	0.15~30MHz	0.15	-53.34	-23	PASS
Band4	1513	1	30~1000MHz	931.58	-56.8	-13	PASS
Band4	1513	1	1000~3000MHz	2673	-51.75	-13	PASS
Band4	1513	1	3000~20000MHz	17036.9	-40.39	-13	PASS
Band4	1513	2	1000~3000MHz	2680.4	-51.74	-13	PASS
Band4	1513	2	0.15~30MHz	1.07	-52.13	-23	PASS
Band4	1513	2	30~1000MHz	806.97	-56.95	-13	PASS
Band4	1513	2	0.009~0.15MHz	0.09	-64.92	-43	PASS
Band4	1513	2	3000~20000MHz	17019.9	-40.54	-13	PASS
Band4	1513	3	30~1000MHz	850.43	-55.94	-13	PASS
Band4	1513	3	1000~3000MHz	2675.2	-51.8	-13	PASS
Band4	1513	3	0.15~30MHz	3.76	-50.79	-23	PASS
Band4	1513	3	0.009~0.15MHz	0.01	-66.95	-43	PASS
Band4	1513	3	3000~20000MHz	17020.47	-40.46	-13	PASS
Band4	1513	4	30~1000MHz	977.33	-56.78	-13	PASS
Band4	1513	4	1000~3000MHz	2686.87	-51.5	-13	PASS
Band4	1513	4	0.15~30MHz	1.08	-52.76	-23	PASS
Band4	1513	4	0.009~0.15MHz	0.14	-65.88	-43	PASS
Band4	1513	4	3000~20000MHz	17035.77	-40.49	-13	PASS



Band5	4132	1	0.009~0.15MHz	0.01	-66.41	-33	PASS
Band5	4132	1	0.15~30MHz	0.15	-52.38	-13	PASS
Band5	4132	1	30~1000MHz	942.83	-65.18	-13	PASS
Band5	4132	1	1000~10000MHz	3188.8	-48.2	-13	PASS
Band5	4132	2	0.15~30MHz	0.15	-52.59	-13	PASS
Band5	4132	2	0.009~0.15MHz	0.01	-66.04	-33	PASS
Band5	4132	2	1000~10000MHz	3181.3	-48.23	-13	PASS
Band5	4132	2	30~1000MHz	517.39	-64.55	-13	PASS
Band5	4132	3	0.009~0.15MHz	0.01	-66.77	-33	PASS
Band5	4132	3	1000~10000MHz	3185.5	-48.19	-13	PASS
Band5	4132	3	30~1000MHz	936.66	-64.57	-13	PASS
Band5	4132	3	0.15~30MHz	0.15	-52.92	-13	PASS
Band5	4132	4	0.009~0.15MHz	0.01	-65.67	-33	PASS
Band5	4132	4	1000~10000MHz	3188.8	-48.17	-13	PASS
Band5	4132	4	0.15~30MHz	0.15	-53.85	-13	PASS
Band5	4132	4	30~1000MHz	496.89	-64.77	-13	PASS
Band5	4182	1	30~1000MHz	961.78	-64.91	-13	PASS
Band5	4182	1	0.009~0.15MHz	0.01	-66.34	-33	PASS
Band5	4182	1	0.15~30MHz	0.15	-52.64	-13	PASS
Band5	4182	1	1000~10000MHz	3166	-48.25	-13	PASS
Band5	4182	2	30~1000MHz	662.93	-65.03	-13	PASS
Band5	4182	2	1000~10000MHz	3056.5	-48.23	-13	PASS
Band5	4182	2	0.15~30MHz	0.15	-53.52	-13	PASS
Band5	4182	2	0.009~0.15MHz	0.01	-66.5	-33	PASS
Band5	4182	3	0.009~0.15MHz	0.01	-65.47	-33	PASS
Band5	4182	3	30~1000MHz	719.35	-64.93	-13	PASS
Band5	4182	3	0.15~30MHz	0.15	-52.75	-13	PASS
Band5	4182	3	1000~10000MHz	3170.8	-48.24	-13	PASS
Band5	4182	4	0.009~0.15MHz	0.01	-67.34	-33	PASS
Band5	4182	4	1000~10000MHz	3174.4	-48.07	-13	PASS
Band5	4182	4	30~1000MHz	998.45	-64.62	-13	PASS
Band5	4182	4	0.15~30MHz	0.15	-53.59	-13	PASS
Band5	4233	1	30~1000MHz	978.85	-64.63	-13	PASS
Band5	4233	1	1000~10000MHz	3188.8	-48.16	-13	PASS
Band5	4233	1	0.009~0.15MHz	0.01	-66.24	-33	PASS
Band5	4233	1	0.15~30MHz	0.15	-52.69	-13	PASS
Band5	4233	2	1000~10000MHz	3181.9	-48.14	-13	PASS
Band5	4233	2	30~1000MHz	954.7	-64.19	-13	PASS
Band5	4233	2	0.15~30MHz	0.15	-54.32	-13	PASS
Band5	4233	2	0.009~0.15MHz	0.01	-65.89	-33	PASS
Band5	4233	3	1000~10000MHz	3192.4	-48.33	-13	PASS
Band5	4233	3	30~1000MHz	985.39	-65	-13	PASS
Band5	4233	3	0.009~0.15MHz	0.01	-65.6	-33	PASS
Band5	4233	3	0.15~30MHz	0.15	-52.51	-13	PASS
Band5	4233	4	1000~10000MHz	3166	-48.28	-13	PASS
Band5	4233	4	0.009~0.15MHz	0.01	-65.57	-33	PASS
Band5	4233	4	0.15~30MHz	0.16	-54.96	-13	PASS
Band5	4233	4	30~1000MHz	973.81	-65.13	-13	PASS



Band	Channel	SubTest	Frequency Range (Mhz)	Frequency (dBm)	Result (dBm)	Limit (dBm)	Verdict
Band2	9262	1	0.15~30MHz	0.15	-53.13	-23	PASS
Band2	9262	1	30~1000MHz	810.85	-56.3	-13	PASS
Band2	9262	1	1000~3000MHz	2681.13	-52.21	-13	PASS
Band2	9262	1	3000~20000MHz	17007.43	-40.79	-13	PASS
Band2	9262	1	0.009~0.15MHz	0.01	-67.02	-43	PASS
Band2	9262	2	0.15~30MHz	0.15	-54.22	-23	PASS
Band2	9262	2	30~1000MHz	821.23	-55.98	-13	PASS
Band2	9262	2	0.009~0.15MHz	0.09	-65.59	-43	PASS
Band2	9262	2	3000~20000MHz	17030.1	-41.05	-13	PASS
Band2	9262	2	1000~3000MHz	2679.27	-52.17	-13	PASS
Band2	9262	3	30~1000MHz	918.36	-55.92	-13	PASS
Band2	9262	3	0.009~0.15MHz	0.09	-66.18	-43	PASS
Band2	9262	3	1000~3000MHz	2698.47	-52.31	-13	PASS
Band2	9262	3	0.15~30MHz	0.15	-54.1	-23	PASS
Band2	9262	3	3000~20000MHz	17004.6	-40.67	-13	PASS
Band2	9262	4	1000~3000MHz	2674.93	-51.86	-13	PASS
Band2	9262	4	0.009~0.15MHz	0.09	-65.19	-43	PASS
Band2	9262	4	30~1000MHz	958.68	-56.52	-13	PASS
Band2	9262	4	3000~20000MHz	17012.53	-40.56	-13	PASS
Band2	9262	4	0.15~30MHz	0.15	-55.2	-23	PASS
Band2	9262	5	0.009~0.15MHz	0.01	-66.27	-43	PASS
Band2	9262	5	3000~20000MHz	17009.7	-40.35	-13	PASS
Band2	9262	5	0.15~30MHz	3.75	-52.13	-23	PASS
Band2	9262	5	30~1000MHz	80.18	-56.56	-13	PASS
Band2	9262	5	1000~3000MHz	2677.93	-51.88	-13	PASS
Band2	9400	1	3000~20000MHz	17031.23	-41.05	-13	PASS
Band2	9400	1	0.009~0.15MHz	0.14	-66.44	-43	PASS
Band2	9400	1	0.15~30MHz	0.16	-54.77	-23	PASS
Band2	9400	1	30~1000MHz	714.98	-56.44	-13	PASS
Band2	9400	1	1000~3000MHz	2685.87	-52.09	-13	PASS
Band2	9400	2	1000~3000MHz	2685.67	-52.09	-13	PASS
Band2	9400	2	30~1000MHz	935.43	-56.35	-13	PASS
Band2	9400	2	0.15~30MHz	0.16	-53.16	-23	PASS
Band2	9400	2	0.009~0.15MHz	0.01	-66.62	-43	PASS
Band2	9400	2	3000~20000MHz	17018.77	-40.85	-13	PASS
Band2	9400	3	3000~20000MHz	17010.83	-40.53	-13	PASS
Band2	9400	3	0.009~0.15MHz	0.01	-64.98	-43	PASS
Band2	9400	3	0.15~30MHz	0.16	-54.4	-23	PASS
Band2	9400	3	30~1000MHz	907.56	-56.11	-13	PASS
Band2	9400	3	1000~3000MHz	2669.53	-51.97	-13	PASS
Band2	9400	4	0.15~30MHz	3.76	-52.18	-23	PASS
Band2	9400	4	30~1000MHz	904.39	-56.28	-13	PASS
Band2	9400	4	0.009~0.15MHz	0.01	-65.8	-43	PASS
Band2	9400	4	1000~3000MHz	2681.07	-51.86	-13	PASS
Band2	9400	4	3000~20000MHz	17017.63	-40.41	-13	PASS
Band2	9400	5	0.15~30MHz	3.75	-52.22	-23	PASS
Band2	9400	5	30~1000MHz	80.18	-54.92	-13	PASS
Band2	9400	5	3000~20000MHz	16999.5	-40.49	-13	PASS
Band2	9400	5	0.009~0.15MHz	0.09	-64.58	-43	PASS
Band2	9400	5	1000~3000MHz	2691.73	-51.72	-13	PASS
Band2	9538	1	0.009~0.15MHz	0.09	-64.65	-43	PASS
Band2	9538	1	0.15~30MHz	0.15	-54.4	-23	PASS
Band2	9538	1	30~1000MHz	80.18	-55.98	-13	PASS
Band2	9538	1	3000~20000MHz	17018.2	-41.13	-13	PASS



Band2	9538	1	1000~3000MHz	2682.47	-52.19	-13	PASS
Band2	9538	2	3000~20000MHz	17015.37	-41.01	-13	PASS
Band2	9538	2	0.15~30MHz	0.15	-54.59	-23	PASS
Band2	9538	2	0.009~0.15MHz	0.01	-67.24	-43	PASS
Band2	9538	2	30~1000MHz	80.31	-56.53	-13	PASS
Band2	9538	2	1000~3000MHz	2685	-52.13	-13	PASS
Band2	9538	3	30~1000MHz	79.92	-56.3	-13	PASS
Band2	9538	3	0.15~30MHz	0.16	-54.52	-23	PASS
Band2	9538	3	1000~3000MHz	2679.53	-51.79	-13	PASS
Band2	9538	3	3000~20000MHz	17030.67	-40.67	-13	PASS
Band2	9538	3	0.009~0.15MHz	0.14	-65.49	-43	PASS
Band2	9538	4	0.15~30MHz	0.16	-53.4	-23	PASS
Band2	9538	4	3000~20000MHz	17019.33	-40.56	-13	PASS
Band2	9538	4	0.009~0.15MHz	0.09	-64.73	-43	PASS
Band2	9538	4	30~1000MHz	831.87	-56.61	-13	PASS
Band2	9538	4	1000~3000MHz	2676.33	-51.82	-13	PASS
Band2	9538	5	3000~20000MHz	17022.73	-40.47	-13	PASS
Band2	9538	5	1000~3000MHz	2692.13	-51.82	-13	PASS
Band2	9538	5	30~1000MHz	848.26	-55.61	-13	PASS
Band2	9538	5	0.15~30MHz	3.76	-52.28	-23	PASS
Band2	9538	5	0.009~0.15MHz	0.09	-65.94	-43	PASS
Band4	1312	1	0.15~30MHz	0.16	-54.84	-23	PASS
Band4	1312	1	0.009~0.15MHz	0.01	-66.34	-43	PASS
Band4	1312	1	30~1000MHz	965.66	-55.85	-13	PASS
Band4	1312	1	1000~3000MHz	2679.73	-51.96	-13	PASS
Band4	1312	1	3000~20000MHz	17009.13	-40.56	-13	PASS
Band4	1312	2	0.009~0.15MHz	0.01	-66.03	-43	PASS
Band4	1312	2	0.15~30MHz	0.16	-52.53	-23	PASS
Band4	1312	2	30~1000MHz	820.49	-56.02	-13	PASS
Band4	1312	2	1000~3000MHz	2674.87	-51.84	-13	PASS
Band4	1312	2	3000~20000MHz	17032.93	-40.49	-13	PASS
Band4	1312	3	3000~20000MHz	17036.33	-40.39	-13	PASS
Band4	1312	3	0.15~30MHz	0.15	-52.91	-23	PASS
Band4	1312	3	30~1000MHz	506.4	-56.1	-13	PASS
Band4	1312	3	1000~3000MHz	2678.8	-51.71	-13	PASS
Band4	1312	3	0.009~0.15MHz	0.01	-66.64	-43	PASS
Band4	1312	4	3000~20000MHz	17027.27	-40.3	-13	PASS
Band4	1312	4	0.009~0.15MHz	0.01	-65.79	-43	PASS
Band4	1312	4	0.15~30MHz	0.15	-53.61	-23	PASS
Band4	1312	4	1000~3000MHz	2682.93	-51.79	-13	PASS
Band4	1312	4	30~1000MHz	790.61	-55.12	-13	PASS
Band4	1312	5	1000~3000MHz	2676.47	-51.68	-13	PASS
Band4	1312	5	30~1000MHz	940.8	-55.8	-13	PASS
Band4	1312	5	0.15~30MHz	0.17	-53.84	-23	PASS
Band4	1312	5	3000~20000MHz	17013.1	-40.42	-13	PASS
Band4	1312	5	0.009~0.15MHz	0.01	-65.46	-43	PASS
Band4	1413	1	0.15~30MHz	0.15	-52.89	-23	PASS
Band4	1413	1	0.009~0.15MHz	0.01	-67	-43	PASS
Band4	1413	1	30~1000MHz	820.23	-55.98	-13	PASS
Band4	1413	1	1000~3000MHz	2674.67	-51.94	-13	PASS
Band4	1413	1	3000~20000MHz	17019.9	-40.57	-13	PASS
Band4	1413	2	3000~20000MHz	17045.97	-40.5	-13	PASS
Band4	1413	2	0.009~0.15MHz	0.01	-65.86	-43	PASS
Band4	1413	2	0.15~30MHz	0.15	-53.96	-23	PASS
Band4	1413	2	30~1000MHz	874.09	-55.75	-13	PASS
Band4	1413	2	1000~3000MHz	2670.4	-51.94	-13	PASS



Band4	1413	3	3000~20000MHz	17028.97	-40.47	-13	PASS
Band4	1413	3	0.15~30MHz	0.15	-52.51	-23	PASS
Band4	1413	3	1000~3000MHz	2685.67	-51.83	-13	PASS
Band4	1413	3	0.009~0.15MHz	0.01	-66.29	-43	PASS
Band4	1413	3	30~1000MHz	726.52	-55.87	-13	PASS
Band4	1413	4	3000~20000MHz	17004.03	-40.34	-13	PASS
Band4	1413	4	1000~3000MHz	2683.8	-51.7	-13	PASS
Band4	1413	4	30~1000MHz	931.84	-56.1	-13	PASS
Band4	1413	4	0.15~30MHz	0.16	-53.82	-23	PASS
Band4	1413	4	0.009~0.15MHz	0.01	-65.42	-43	PASS
Band4	1413	5	0.009~0.15MHz	0.01	-65.85	-43	PASS
Band4	1413	5	0.15~30MHz	0.15	-53.8	-23	PASS
Band4	1413	5	30~1000MHz	921.27	-55.38	-13	PASS
Band4	1413	5	3000~20000MHz	17008	-40.29	-13	PASS
Band4	1413	5	1000~3000MHz	2696.8	-51.75	-13	PASS
Band4	1513	1	3000~20000MHz	16995.53	-40.58	-13	PASS
Band4	1513	1	1000~3000MHz	2683.47	-52.09	-13	PASS
Band4	1513	1	30~1000MHz	979.4	-56.16	-13	PASS
Band4	1513	1	0.15~30MHz	0.15	-54.51	-23	PASS
Band4	1513	1	0.009~0.15MHz	0.01	-67.14	-43	PASS
Band4	1513	2	0.15~30MHz	0.15	-52.69	-23	PASS
Band4	1513	2	30~1000MHz	805.03	-55.72	-13	PASS
Band4	1513	2	3000~20000MHz	17022.73	-40.24	-13	PASS
Band4	1513	2	1000~3000MHz	2670.8	-51.97	-13	PASS
Band4	1513	2	0.009~0.15MHz	0.01	-66.51	-43	PASS
Band4	1513	3	0.009~0.15MHz	0.01	-66	-43	PASS
Band4	1513	3	0.15~30MHz	0.15	-51.75	-23	PASS
Band4	1513	3	30~1000MHz	876.49	-55.9	-13	PASS
Band4	1513	3	1000~3000MHz	2675.2	-51.77	-13	PASS
Band4	1513	3	3000~20000MHz	17007.43	-40.41	-13	PASS
Band4	1513	4	1000~3000MHz	2682.27	-51.73	-13	PASS
Band4	1513	4	3000~20000MHz	17027.83	-40.35	-13	PASS
Band4	1513	4	0.009~0.15MHz	0.01	-64.99	-43	PASS
Band4	1513	4	0.15~30MHz	0.15	-53.37	-23	PASS
Band4	1513	4	30~1000MHz	837.07	-56.17	-13	PASS
Band4	1513	5	3000~20000MHz	17013.67	-40.29	-13	PASS
Band4	1513	5	0.15~30MHz	0.15	-54.25	-23	PASS
Band4	1513	5	30~1000MHz	937.98	-56.1	-13	PASS
Band4	1513	5	1000~3000MHz	2678.67	-51.71	-13	PASS
Band4	1513	5	0.009~0.15MHz	0.01	-66.4	-43	PASS
Band5	4132	1	1000~10000MHz	3179.8	-48.29	-13	PASS
Band5	4132	1	30~1000MHz	946.26	-64.92	-13	PASS
Band5	4132	1	0.009~0.15MHz	0.01	-65.13	-33	PASS
Band5	4132	1	0.15~30MHz	0.15	-52.71	-13	PASS
Band5	4132	2	0.15~30MHz	0.15	-53.51	-13	PASS
Band5	4132	2	0.009~0.15MHz	0.01	-65.76	-33	PASS
Band5	4132	2	1000~10000MHz	3182.8	-48.3	-13	PASS
Band5	4132	2	30~1000MHz	979.37	-64.93	-13	PASS
Band5	4132	3	0.15~30MHz	0.15	-53.37	-13	PASS
Band5	4132	3	30~1000MHz	968.77	-64.72	-13	PASS
Band5	4132	3	0.009~0.15MHz	0.01	-66.68	-33	PASS
Band5	4132	3	1000~10000MHz	3195.4	-48.34	-13	PASS
Band5	4132	4	0.15~30MHz	0.16	-54.35	-13	PASS
Band5	4132	4	1000~10000MHz	3180.4	-48.38	-13	PASS
Band5	4132	4	0.009~0.15MHz	0.01	-66.56	-33	PASS
Band5	4132	4	30~1000MHz	948.46	-65	-13	PASS



Band5	4132	5	0.15~30MHz	0.16	-53.66	-13	PASS
Band5	4132	5	0.009~0.15MHz	0.01	-66.49	-33	PASS
Band5	4132	5	30~1000MHz	927.44	-65.14	-13	PASS
Band5	4132	5	1000~10000MHz	3185.5	-48.42	-13	PASS
Band5	4182	1	0.009~0.15MHz	0.01	-66.09	-33	PASS
Band5	4182	1	30~1000MHz	998.19	-65.46	-13	PASS
Band5	4182	1	0.15~30MHz	0.15	-53.24	-13	PASS
Band5	4182	1	1000~10000MHz	3190	-48.26	-13	PASS
Band5	4182	2	0.009~0.15MHz	0.01	-64.97	-33	PASS
Band5	4182	2	0.15~30MHz	0.15	-54.45	-13	PASS
Band5	4182	2	30~1000MHz	985.35	-65.19	-13	PASS
Band5	4182	2	1000~10000MHz	3182.8	-48.39	-13	PASS
Band5	4182	3	30~1000MHz	962.66	-64.62	-13	PASS
Band5	4182	3	0.15~30MHz	0.15	-52.36	-13	PASS
Band5	4182	3	1000~10000MHz	3196.3	-48.38	-13	PASS
Band5	4182	3	0.009~0.15MHz	0.01	-66.05	-33	PASS
Band5	4182	4	0.009~0.15MHz	0.01	-65.87	-33	PASS
Band5	4182	4	30~1000MHz	973.65	-65.26	-13	PASS
Band5	4182	4	1000~10000MHz	3186.1	-48.35	-13	PASS
Band5	4182	4	0.15~30MHz	0.15	-52.56	-13	PASS
Band5	4182	5	0.009~0.15MHz	0.01	-67.24	-33	PASS
Band5	4182	5	0.15~30MHz	0.16	-52.57	-13	PASS
Band5	4182	5	1000~10000MHz	3177.1	-48.49	-13	PASS
Band5	4182	5	30~1000MHz	944.71	-65.17	-13	PASS
Band5	4233	1	0.15~30MHz	0.15	-52.76	-13	PASS
Band5	4233	1	0.009~0.15MHz	0.01	-66.19	-33	PASS
Band5	4233	1	30~1000MHz	975.27	-65.12	-13	PASS
Band5	4233	1	1000~10000MHz	3186.7	-48.26	-13	PASS
Band5	4233	2	1000~10000MHz	3180.7	-48.39	-13	PASS
Band5	4233	2	0.009~0.15MHz	0.01	-65.82	-33	PASS
Band5	4233	2	0.15~30MHz	0.15	-53.81	-13	PASS
Band5	4233	2	30~1000MHz	956.41	-65.26	-13	PASS
Band5	4233	3	1000~10000MHz	3176.2	-48.43	-13	PASS
Band5	4233	3	30~1000MHz	963.53	-64.88	-13	PASS
Band5	4233	3	0.15~30MHz	0.15	-53.65	-13	PASS
Band5	4233	3	0.009~0.15MHz	0.01	-67	-33	PASS
Band5	4233	4	0.009~0.15MHz	0.01	-66.09	-33	PASS
Band5	4233	4	1000~10000MHz	3055.6	-48.28	-13	PASS
Band5	4233	4	30~1000MHz	986.68	-65.19	-13	PASS
Band5	4233	4	0.15~30MHz	0.15	-52.92	-13	PASS
Band5	4233	5	1000~10000MHz	3174.1	-48.37	-13	PASS
Band5	4233	5	0.009~0.15MHz	0.01	-66.45	-33	PASS
Band5	4233	5	0.15~30MHz	0.17	-54.11	-13	PASS
Band5	4233	5	30~1000MHz	722.19	-64.9	-13	PASS



Test Graphs:

Band2-9262-0.009~0.15MHz



Band2-9262-0.15~30MHz

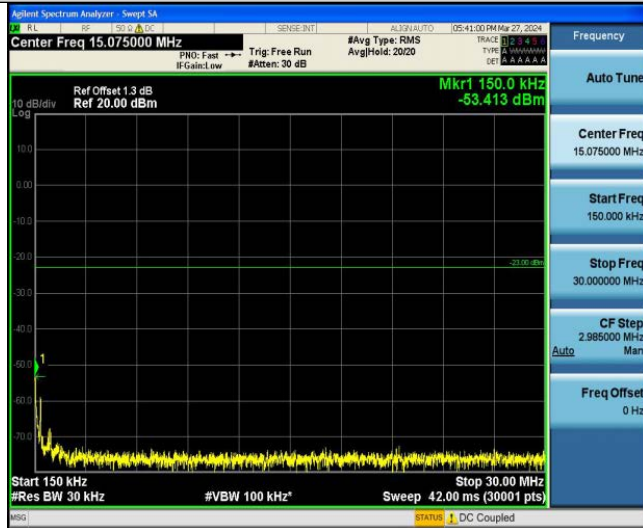

Band2-9262-30~1000MHz

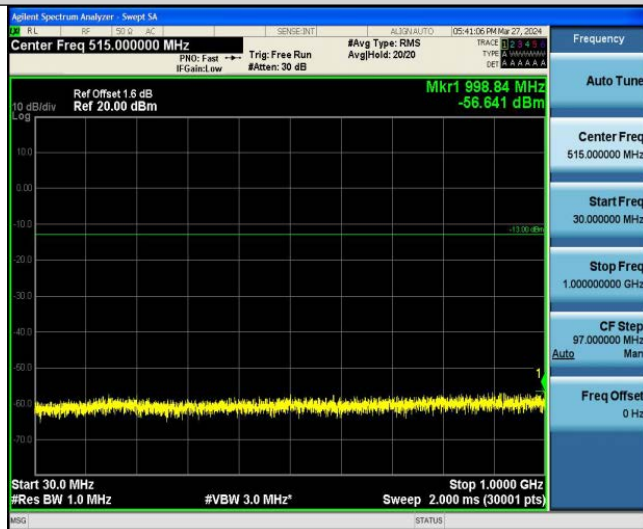

Band2-9262-1000~3000MHz



Band2-9262-3000~20000MHz



Band2-9400-0.009~0.15MHz



Band2-9400-0.15~30MHz

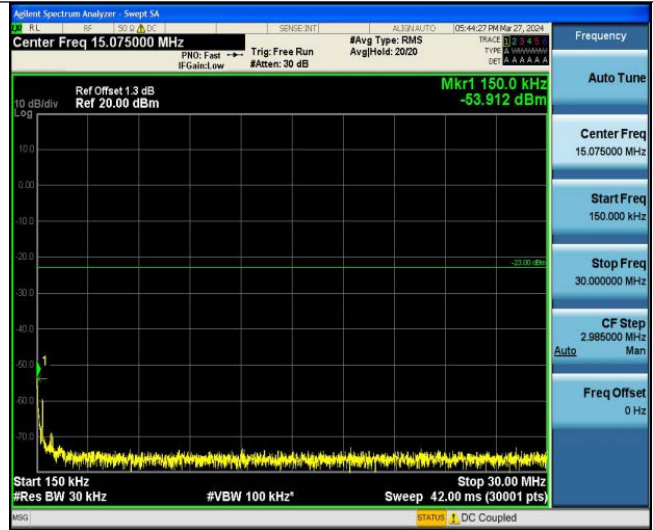

Band2-9400-30~1000MHz

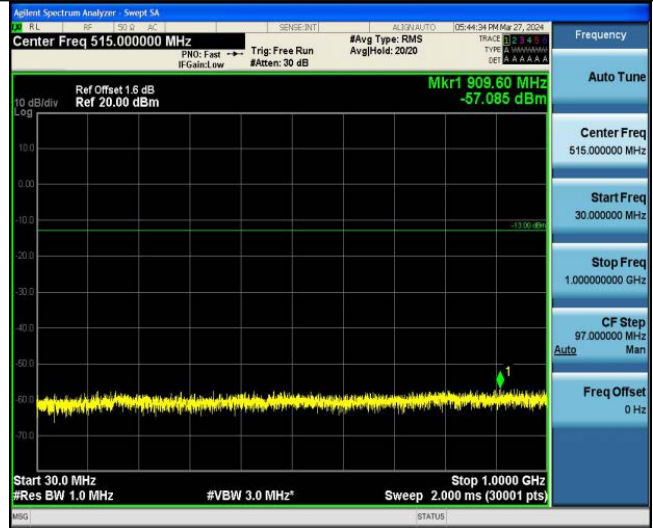

Band2-9400-1000~3000MHz



Band2-9400-3000~20000MHz



Band2-9538-0.009~0.15MHz



Band2-9538-0.15~30MHz



Band2-9538-30~1000MHz

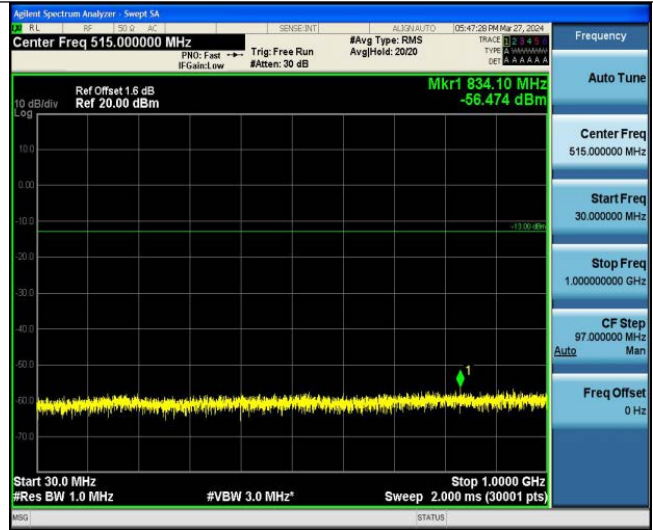

Band2-9538-1000~3000MHz



Band2-9538-3000~20000MHz



Band4-1312-0.009~0.15MHz



Band4-1312-0.15~30MHz



Band4-1312-30~1000MHz

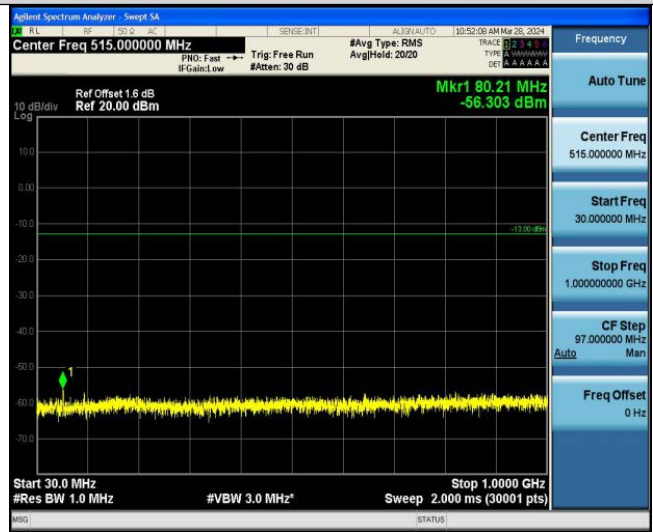

Band4-1312-1000~3000MHz



Band4-1312-3000~20000MHz



Band4-1413-0.009~0.15MHz



Band4-1413-0.15~30MHz



Band4-1413-30~1000MHz

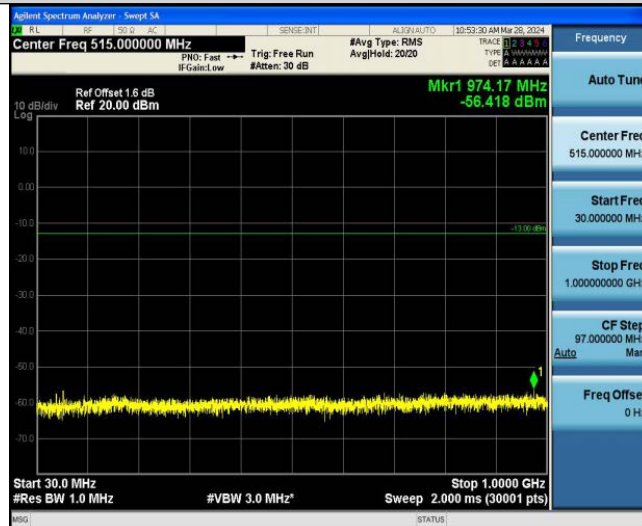

Band4-1413-1000~3000MHz

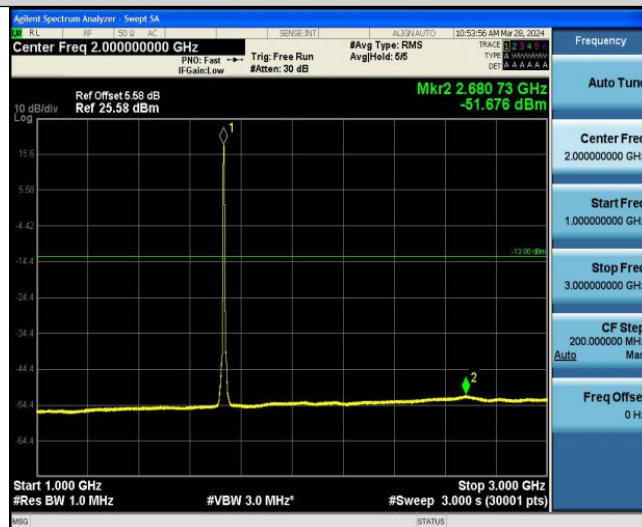

Band4-1413-3000~20000MHz



Band4-1513-0.009~0.15MHz



Band4-1513-0.15~30MHz



Band4-1513-30~100MHz

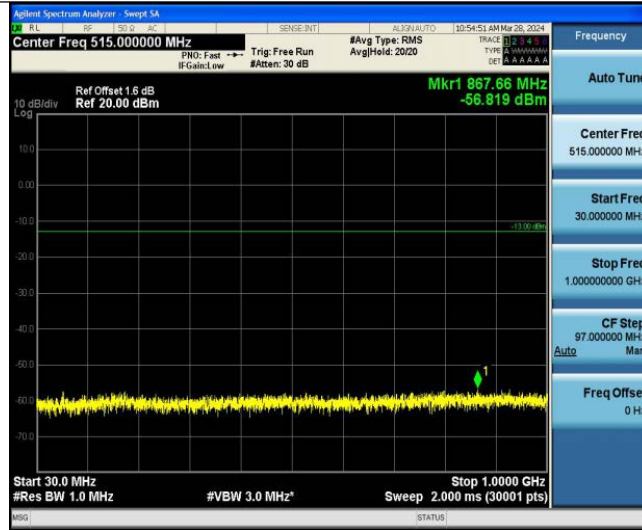

Band4-1513-1000~3000MHz

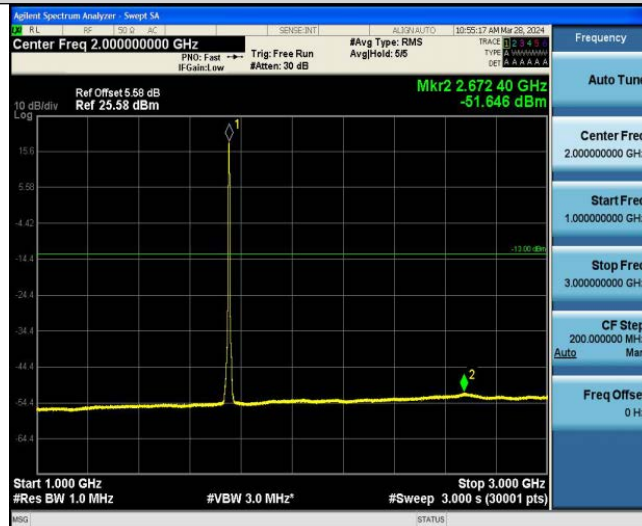

Band4-1513-3000~20000MHz



Band5-4132-0.009~0.15MHz



Band5-4132-0.15~30MHz



Band5-4132-30~1000MHz

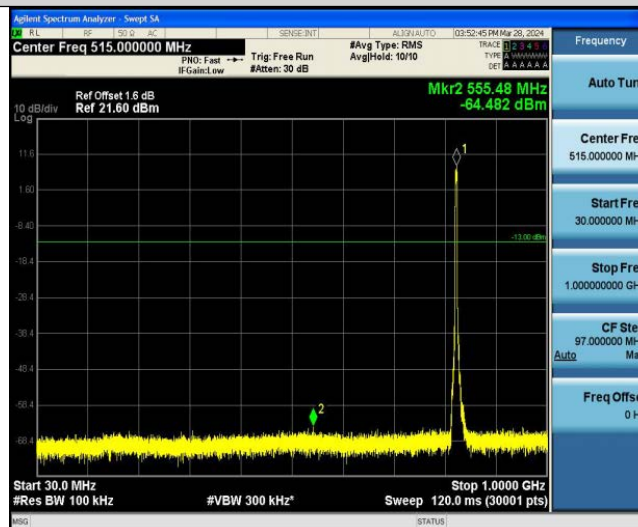

Band5-4132-1000~10000MHz



Band5-4182-0.009~0.15MHz



Band5-4182-0.15~30MHz

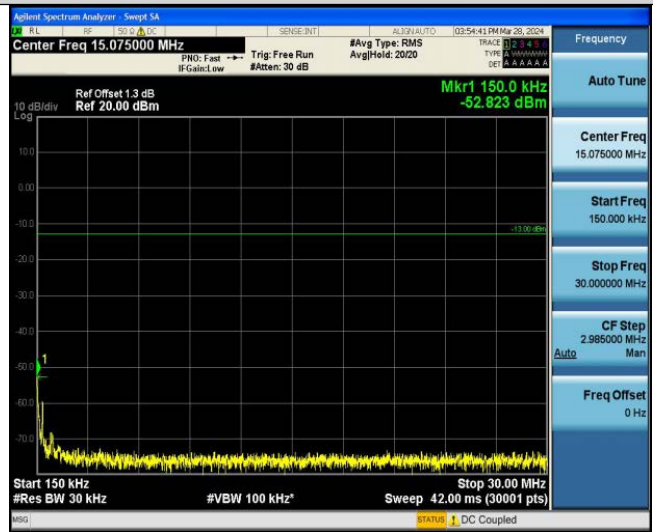

Band5-4182-30~100MHz

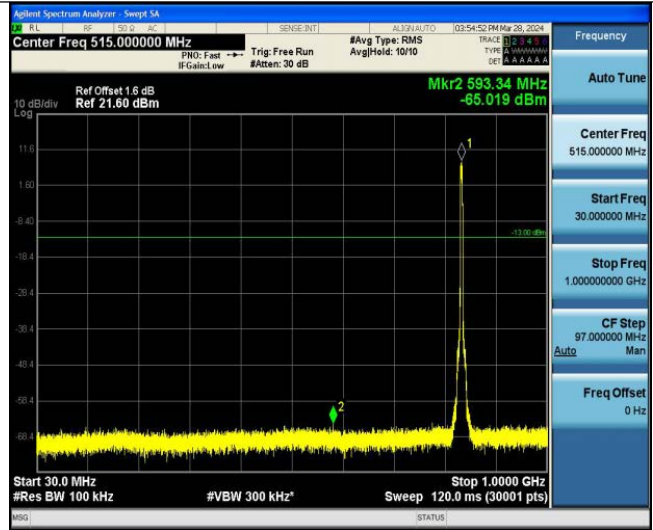

Band5-4182-1000~10000MHz



Band5-4233-0.009~0.15MHz



Band5-4233-0.15~30MHz

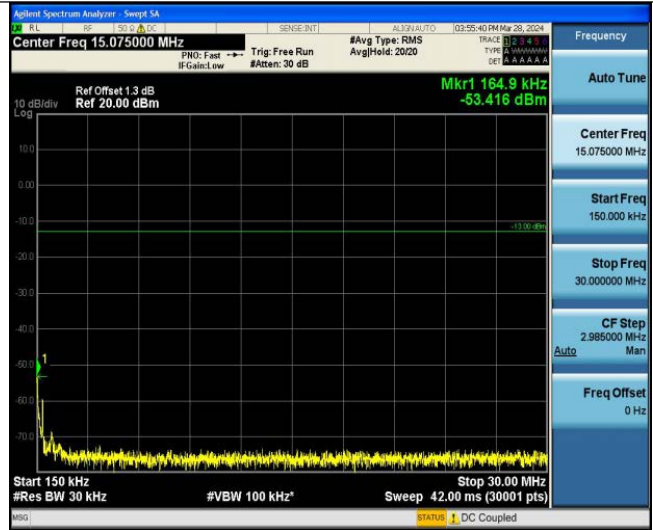

Band5-4233-30~1000MHz

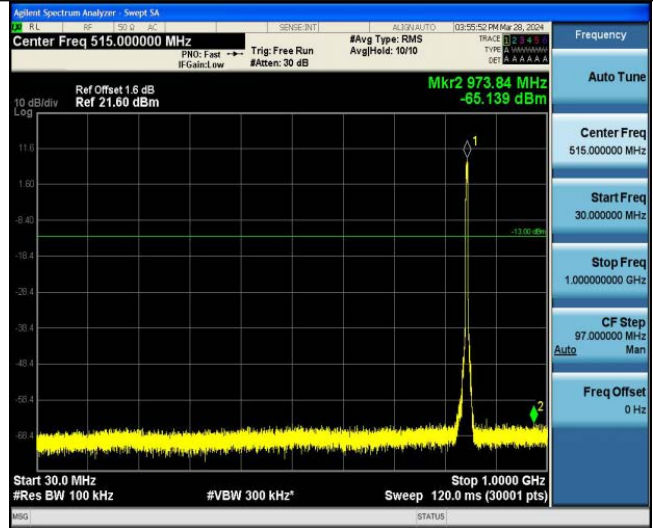

Band5-4233-1000~10000MHz



Radiated method

Test limit:

The spurious (unwanted) emission limits specified in the individual FCC rule parts applicable to licensed digital transmitters (typically referred to under the heading 'emission limits') normally apply to any and all emissions that are present outside of the authorized frequency band/block and apply to emissions in both the out-of-band and spurious domains. In some rule parts, the unwanted emission limits are specified by an emission mask that defines the applicable limit as a function of the frequency range relative to the authorized frequency block.

Typically, unwanted emissions are required by the licensed rule parts to be attenuated below the transmitter power by a factor of at least $X + 10\log(P)$ dB, where P represents the transmitter power expressed in watts and X is a specified scalar value (e.g., 43). This specification can be interpreted in one of two equivalent ways. First, the required attenuation can be construed to be relative to the mean carrier power, with the resultant of the equation $X + 10\log(P)$ being expressed in dBc (dB relative to the maximum carrier power). Alternatively, the specification can be interpreted as an absolute limit when the specified attenuation is actually subtracted from the maximum permissible transmitter power [i.e., $10\log(P) - \{X + 10\log(P)\}$], resulting in an absolute level of -X dBW [or $(-X + 30)$ dBm]. See section 4.

Test procedure:

The radiated emission tests were performed in the 3m Semi- Anechoic Chamber test site. The resolution bandwidth of the spectrum analyzer was set at 100 kHz below 1 GHz and 1 MHz above 1 GHz. Sufficient scans were taken to show any out of band emissions up to 10th harmonics.

Test setup:

(A) Radiated Emission Test-Up Frequency 30MHz~1GHz

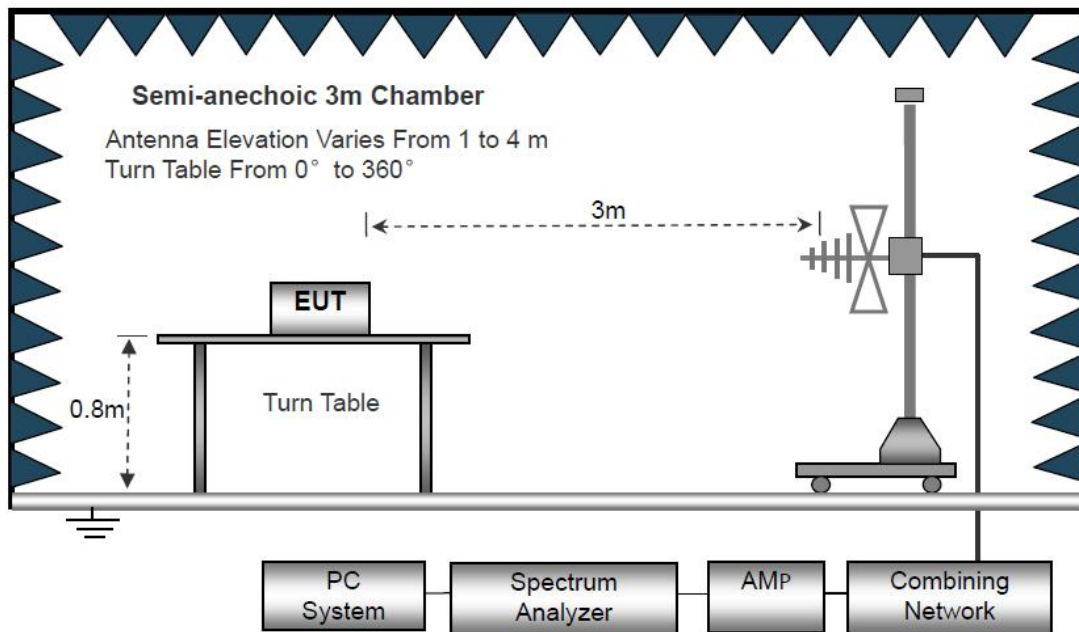

(B) Radiated Emission Test-Up Frequency Above 1GHz

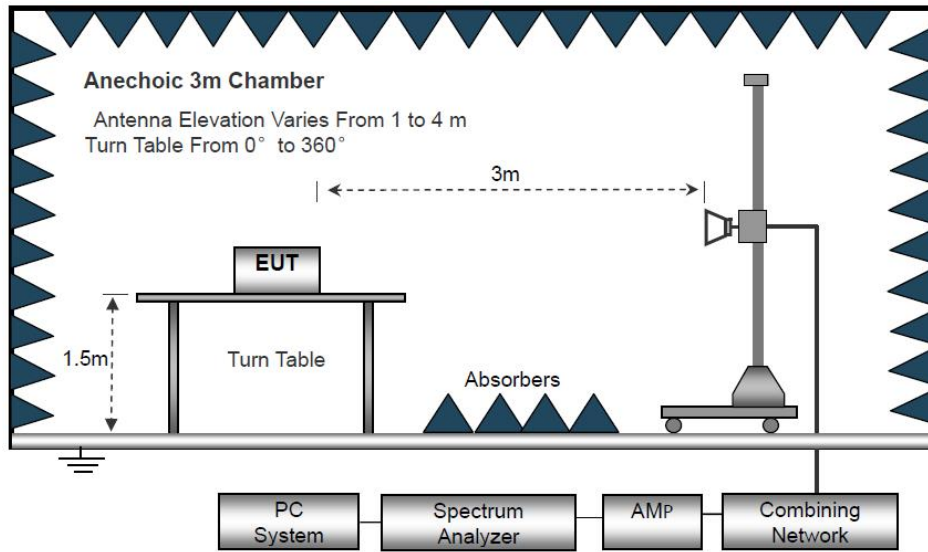

Note:

- 1, Below 30MHz no Spurious found.
- 2, UE is positioned at 3 axis at the pre-scan stage, and only the measurement of the worst case is reported in this part.



List of final test modes:

WCDMA BAND II:

Test Channel	BW(MHz)	UL Channel	Frequency(MHz)	Judgment
Low Range	0.2	9262	1852.4	Pass
Middle Range	0.2	9400	1880	Pass
High Range	0.2	9538	1907.6	Pass

WCDMA BAND IV:

Test Channel	BW(MHz)	UL Channel	Frequency(MHz)	Judgment
Low Range	0.2	1312	1712.4	Pass
Middle Range	0.2	1413	1732.6	Pass
High Range	0.2	1513	1752.6	Pass

WCDMA BAND V:

Test Channel	BW(MHz)	UL Channel	Frequency(MHz)	Judgment
Low Range	5	4132	826.4	Pass
Middle Range	5	4182	836.4	Pass
High Range	5	4233	846.6	Pass

Note: All modes have been tested and only the worst modes are recorded in the report.



Test record:

WCDMA band II:

Middle Channel

Frequency(MHz)	Reading level(dBm)	Factor(dB)	Level (dBm)	Limit (dBm)	Margin (dBm)	Polarity
3760	-50.09	-1.04	-51.13	-13.00	38.13	Horizontal
5640	-50.94	6.05	-44.89	-13.00	31.89	Horizontal
3760	-50.20	-1.04	-51.24	-13.00	38.24	Vertical
5640	-50.19	6.05	-44.14	-13.00	31.14	Vertical

Note:1. Level= Reading level+ Factor. Margin=Limit-Level.

2. The emission levels of below 1 GHz are lower than the limit 10dB, so not show in test report.

WCDMA band IV:

Middle Channel

Frequency(MHz)	Reading level(dBm)	Factor(dB)	Level (dBm)	Limit (dBm)	Margin (dBm)	Polarity
3465.00	-48.1	-2.43	-50.53	-13.00	37.53	Horizontal
5197.50	-41.2	4.14	-37.06	-13.00	24.06	Horizontal
6930.20	-48.81	10.97	-37.84	-13.00	24.84	Horizontal
3465.00	-49.17	-2.18	-51.35	-13.00	38.35	Vertical
5197.50	-42.59	3.76	-38.83	-13.00	25.83	Vertical
6930.20	-47.86	9.52	-38.34	-13.00	25.34	Vertical

Note:1. Level= Reading level+ Factor. Margin=Limit-Level.

2. The emission levels of below 1 GHz are lower than the limit 10dB, so not show in test report.

WCDMA band V:

Highest Channel

Frequency(MHz)	Reading level(dBm)	Factor(dB)	Level (dBm)	Limit (dBm)	Margin (dBm)	Polarity
1693.20	-49.34	-11.08	-60.42	-13.00	47.42	Horizontal
2546.40	-39.91	-6.35	-46.26	-13.00	33.26	Horizontal
3386.40	-47.04	-5.17	-52.21	-13.00	39.213	Horizontal
1693.20	-49.28	-11.08	-60.36	-13.00	47.36	Vertical
2546.40	-30.18	-6.35	-36.53	-13.00	23.53	Vertical
3386.40	-46.64	-5.17	-51.81	-13.00	38.81	Vertical

Note:1. Level= Reading level+ Factor. Margin=Limit-Level.

2. The emission levels of below 1 GHz are lower than the limit 10dB, so not show in test report.



7. Occupied Bandwidth and Emission Bandwidth

Test limit:

The occupied bandwidth (OBW), that is the frequency bandwidth such that, below its lower and above its upper frequency limits, the mean powers radiated are each equal to 0.5 percent of the total mean power radiated by a given emission, shall be measured when modulated by an input signal such that its amplitude and symbol rate represent the maximum rated conditions under which the equipment will be operated. The signal shall be applied through any filter networks, pseudo-random generators or other devices required in normal service. Additionally, the occupied bandwidth shall be shown for operation with any devices used for modifying the spectrum when such devices are optional at the discretion of the user. [i2.1049(h)]

Many of the individual rule parts specify a relative OBW in lieu of the 99% OBW. In such cases, the OBW is defined as the width of the signal between two points, one below the carrier center frequency and one above the carrier center frequency, outside of which all emissions are attenuated by at least X dB below the transmitter power, where the value of X is typically specified as 26.

The relative OBW must be measured and reported when it is specified in the applicable rule part; otherwise, the 99% OBW shall be measured and reported. The test report shall specify which OBW is reported.

A spectrum/signal analyzer or other instrument providing a spectral display is recommended for these measurements and the video bandwidth shall be set to a value at least three times greater than the IF/resolution bandwidth to avoid any amplitude smoothing. Video filtering shall not be used during occupied bandwidth tests.

The OBW shall be measured for all operating conditions that will affect the bandwidth results (e.g. variable modulations, coding, or channel bandwidth settings). See section 4.

Test procedure:

Occupied bandwidth – relative measurement procedure

The reference value is the highest level of the spectral envelope of the modulated signal.

- a) The spectrum analyzer center frequency is set to the nominal EUT channel center frequency. The span range for the spectrum analyzer shall be between two and five times the anticipated OBW.
- b) The nominal resolution bandwidth (RBW) shall be in the range of 1 to 5 % of the anticipated OBW, and the VBW shall be at least 3 times the RBW.
- c) Set the reference level of the instrument as required to prevent the signal from exceeding the maximum input mixer level for linear operation. In general, the peak of the spectral envelope must be at least $10\log(\text{OBW} / \text{RBW})$ below the reference level.
- d) NOTE—Steps a) through c) may require iteration to adjust within the specified tolerances.
- e) The dynamic range of the spectrum analyzer at the selected RBW shall be at least 10 dB below the target “-X dB down” requirement (i.e., if the requirement calls for measuring the -26 dB OBW, the spectrum analyzer noise floor at the selected RBW shall be at least 36 dB below the reference value).
- f) Set the detection mode to peak, and the trace mode to max hold.
- g) Determine the reference value: Set the EUT to transmit a modulated signal. Allow the trace to stabilize. Set the spectrum analyzer marker to the highest level of the displayed trace (this is the reference value).
- h) Determine the “-X dB down amplitude” as equal to (Reference Value – X). Alternatively,



this calculation can be performed by the analyzer by using the marker-delta function.

i) Place two markers, one at the lowest and the other at the highest frequency of the envelope of the spectral display such that each marker is at or slightly below the “-X dB down amplitude” determined in step g). If a marker is below this “-X dB down amplitude” value it shall be placed as close as possible to this value. The OBW is the positive frequency difference between the two markers.

j) The occupied bandwidth shall be reported by providing plot(s) of the measuring instrument display. The frequency and amplitude axes and scale shall be clearly labeled. Tabular data may be reported in addition to the plot(s).

Occupied bandwidth – power bandwidth (99%) measurement procedure

The following procedure shall be used for measuring (99 %) power bandwidth

a) The spectrum analyzer center frequency is set to the nominal EUT channel center frequency. The frequency span for the spectrum analyzer shall be set wide enough to capture all modulation products including the emission skirts (i.e., two to five times the OBW).

b) The nominal IF filter bandwidth (3 dB RBW) shall be in the range of 1 to 5 % of the anticipated OBW, and the VBW shall be at least 3 times the RBW.

c) Set the reference level of the instrument as required to keep the signal from exceeding the maximum input mixer level for linear operation. In general, the peak of the spectral envelope must be at least $10\log(\text{OBW} / \text{RBW})$ below the reference level.

d) NOTE—Steps a) through c) may require iteration to adjust within the specified tolerances.

e) Set the detection mode to peak, and the trace mode to max hold..

f) Use the 99 % power bandwidth function of the spectrum analyzer (if available) and report the measured bandwidth.

g) If the instrument does not have a 99 % power bandwidth function, the trace data points are to be recovered and directly summed in linear power terms. The recovered amplitude data points, beginning at the lowest frequency, are placed in a running sum until 0.5 % of the total is reached; that frequency is recorded as the lower frequency. The process is repeated until 99.5 % of the total is reached; that frequency is recorded as the upper frequency. The 99 % power bandwidth is the difference between these two frequencies.

h) The OBW shall be reported by providing plot(s) of the measuring instrument display. The frequency and amplitude axes and scale shall be clearly labeled. Tabular data may be reported in addition to the plot(s).

Test setup:

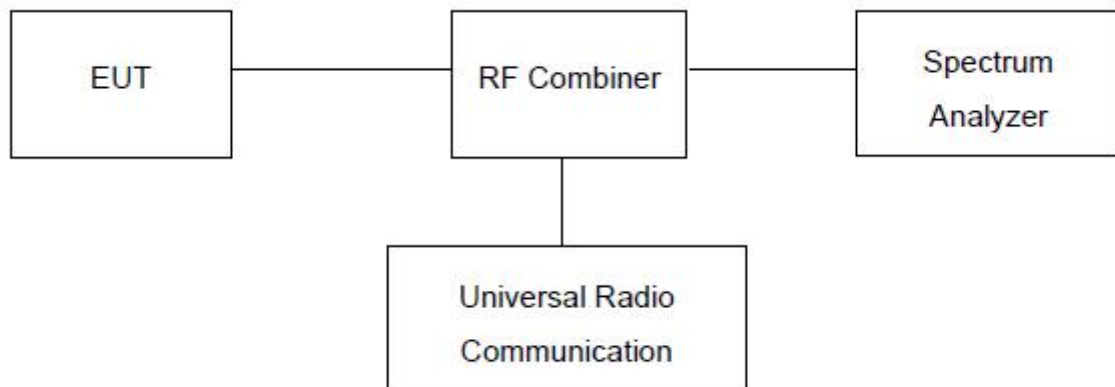



Measurement Result:

Band	Channel	Occupied Bandwidth (kHz)	26dB Bandwidth (kHz)	Limit(kHz)	Verdict
Band2	9262	4.1509	4.741	---	PASS
Band2	9400	4.1318	4.709	---	PASS
Band2	9538	4.1409	4.714	---	PASS
Band4	1312	4.1458	4.725	---	PASS
Band4	1413	4.1368	4.709	---	PASS
Band4	1513	4.1426	4.722	---	PASS
Band5	4132	4.1386	4.724	---	PASS
Band5	4182	4.1405	4.714	---	PASS
Band5	4233	4.1338	4.721	---	PASS

Band	Channel	SubTest	Occupied Bandwidth (kHz)	26dB Bandwidth (kHz)	Limit(kHz)	Verdict
Band2	9262	1	4.1408	4.713	---	PASS
Band2	9262	2	4.1484	4.723	---	PASS
Band2	9262	3	4.1476	4.716	---	PASS
Band2	9262	4	4.1442	4.727	---	PASS
Band2	9400	1	4.1268	4.684	---	PASS
Band2	9400	2	4.1503	4.718	---	PASS
Band2	9400	3	4.1560	4.726	---	PASS
Band2	9400	4	4.1552	4.725	---	PASS
Band2	9538	1	4.1410	4.691	---	PASS
Band2	9538	2	4.1521	4.713	---	PASS
Band2	9538	3	4.1538	4.734	---	PASS
Band2	9538	4	4.1570	4.730	---	PASS
Band4	1312	1	4.1435	4.711	---	PASS
Band4	1312	2	4.1431	4.701	---	PASS
Band4	1312	3	4.1417	4.713	---	PASS
Band4	1312	4	4.1415	4.701	---	PASS
Band4	1413	1	4.1426	4.698	---	PASS
Band4	1413	2	4.1480	4.723	---	PASS
Band4	1413	3	4.1482	4.727	---	PASS
Band4	1413	4	4.1523	4.731	---	PASS
Band4	1513	1	4.1370	4.708	---	PASS
Band4	1513	2	4.1408	4.710	---	PASS
Band4	1513	3	4.1420	4.711	---	PASS
Band4	1513	4	4.1454	4.705	---	PASS
Band5	4132	1	4.1419	4.712	---	PASS
Band5	4132	2	4.1392	4.707	---	PASS
Band5	4132	3	4.1475	4.708	---	PASS
Band5	4132	4	4.1411	4.703	---	PASS
Band5	4182	1	4.1479	4.730	---	PASS
Band5	4182	2	4.1453	4.704	---	PASS
Band5	4182	3	4.1474	4.712	---	PASS
Band5	4182	4	4.1510	4.704	---	PASS
Band5	4233	1	4.1328	4.711	---	PASS
Band5	4233	2	4.1323	4.697	---	PASS
Band5	4233	3	4.1301	4.693	---	PASS
Band5	4233	4	4.1286	4.692	---	PASS



Band	Channel	SubTest	Frequency (MHz)	Result (dBm)	Limit(dBm)	Verdict
Band2	9262	1	1850.00	-24.57	-13	PASS
Band2	9262	2	1850.00	-23.97	-13	PASS
Band2	9262	3	1849.86	-25.10	-13	PASS
Band2	9262	4	1850.00	-24.51	-13	PASS
Band2	9262	5	1850.00	-23.07	-13	PASS
Band2	9538	1	1910.00	-22.84	-13	PASS
Band2	9538	2	1910.12	-22.15	-13	PASS
Band2	9538	3	1910.00	-20.90	-13	PASS
Band2	9538	4	1910.15	-21.37	-13	PASS
Band2	9538	5	1910.16	-23.60	-13	PASS
Band4	1312	1	1710.00	-23.96	-13	PASS
Band4	1312	2	1710.00	-24.74	-13	PASS
Band4	1312	3	1710.00	-24.72	-13	PASS
Band4	1312	4	1710.00	-24.96	-13	PASS
Band4	1312	5	1710.00	-23.97	-13	PASS
Band4	1513	1	1755.17	-23.80	-13	PASS
Band4	1513	2	1755.00	-24.09	-13	PASS
Band4	1513	3	1755.00	-23.64	-13	PASS
Band4	1513	4	1755.08	-25.67	-13	PASS
Band4	1513	5	1755.00	-23.21	-13	PASS
Band5	4132	1	823.97	-18.83	-13	PASS
Band5	4132	2	824.00	-25.52	-13	PASS
Band5	4132	3	823.86	-21.06	-13	PASS
Band5	4132	4	824.00	-25.12	-13	PASS
Band5	4132	5	824.00	-24.76	-13	PASS
Band5	4233	1	849.12	-17.78	-13	PASS
Band5	4233	2	849.00	-24.28	-13	PASS
Band5	4233	3	849.15	-24.63	-13	PASS
Band5	4233	4	849.00	-23.54	-13	PASS
Band5	4233	5	849.00	-24.44	-13	PASS

Band	Channel	SubTest	Occupied Bandwidth (kHz)	26dB Bandwidth (kHz)	Limit(kHz)	Verdict
Band2	9262	1	4.1494	4.733	---	PASS
Band2	9262	2	4.1570	4.721	---	PASS
Band2	9262	3	4.1531	4.741	---	PASS
Band2	9262	4	4.1456	4.726	---	PASS
Band2	9262	5	4.1511	4.697	---	PASS
Band2	9400	1	4.1624	4.710	---	PASS
Band2	9400	2	4.1375	4.673	---	PASS
Band2	9400	3	4.1657	4.751	---	PASS
Band2	9400	4	4.1420	4.694	---	PASS
Band2	9400	5	4.1430	4.693	---	PASS
Band2	9538	1	4.1738	4.730	---	PASS
Band2	9538	2	4.1693	4.725	---	PASS
Band2	9538	3	4.1863	4.728	---	PASS
Band2	9538	4	4.1715	4.724	---	PASS
Band2	9538	5	4.1344	4.706	---	PASS
Band4	1312	1	4.1435	4.735	---	PASS
Band4	1312	2	4.1434	4.716	---	PASS
Band4	1312	3	4.1482	4.729	---	PASS
Band4	1312	4	4.1397	4.710	---	PASS
Band4	1312	5	4.1443	4.722	---	PASS
Band4	1413	1	4.1689	4.728	---	PASS
Band4	1413	2	4.1348	4.721	---	PASS



Band4	1413	3	4.1830	4.746	---	PASS
Band4	1413	4	4.1359	4.701	---	PASS
Band4	1413	5	4.1380	4.711	---	PASS
Band4	1513	1	4.1664	4.737	---	PASS
Band4	1513	2	4.1657	4.736	---	PASS
Band4	1513	3	4.1425	4.702	---	PASS
Band4	1513	4	4.1653	4.735	---	PASS
Band4	1513	5	4.1402	4.729	---	PASS
Band5	4132	1	4.1756	4.727	---	PASS
Band5	4132	2	4.1464	4.735	---	PASS
Band5	4132	3	4.1608	5.113	---	PASS
Band5	4132	4	4.1398	4.707	---	PASS
Band5	4132	5	4.1371	4.703	---	PASS
Band5	4182	1	4.1388	4.727	---	PASS
Band5	4182	2	4.1605	4.734	---	PASS
Band5	4182	3	4.1461	4.691	---	PASS
Band5	4182	4	4.1524	4.730	---	PASS
Band5	4182	5	4.1428	4.730	---	PASS
Band5	4233	1	4.1546	4.736	---	PASS
Band5	4233	2	4.1602	4.728	---	PASS
Band5	4233	3	4.1631	4.716	---	PASS
Band5	4233	4	4.1688	4.726	---	PASS
Band5	4233	5	4.1590	4.710	---	PASS



Test Graphs:





Band4-1312

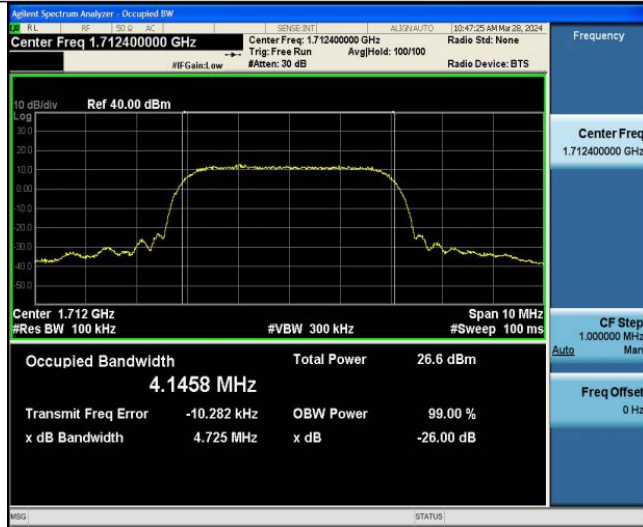

Band4-1413



Band4-1513



Band5-4132



Band5-4182



Band5-4233





Band2-9262-1

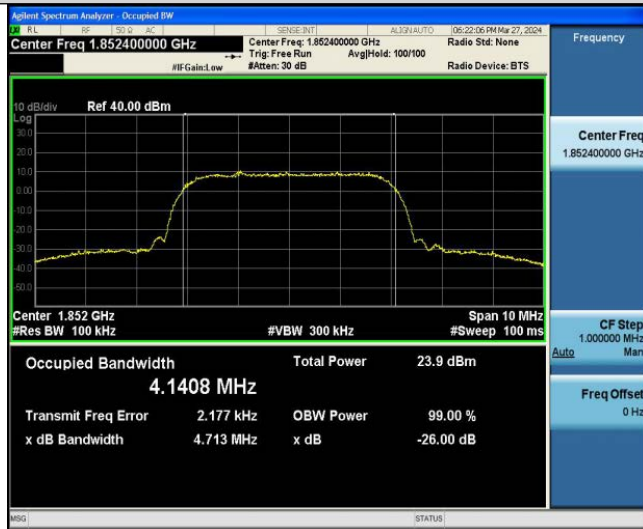

Band2-9262-2



Band2-9262-3



Band2-9262-4

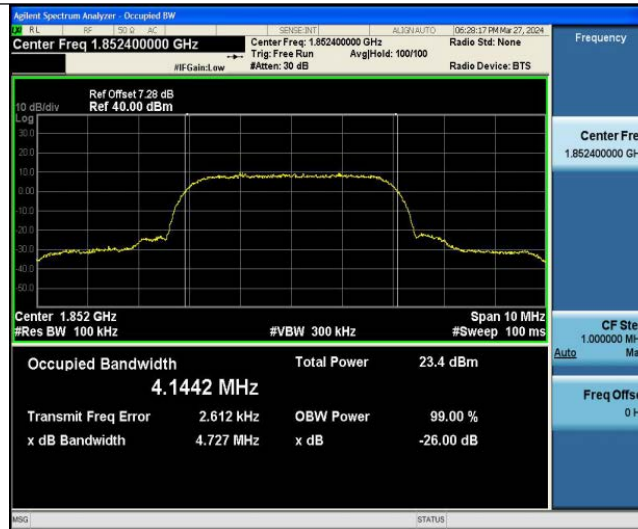

Band2-9400-1



Band2-9400-2



Band2-9400-3



Band2-9400-4

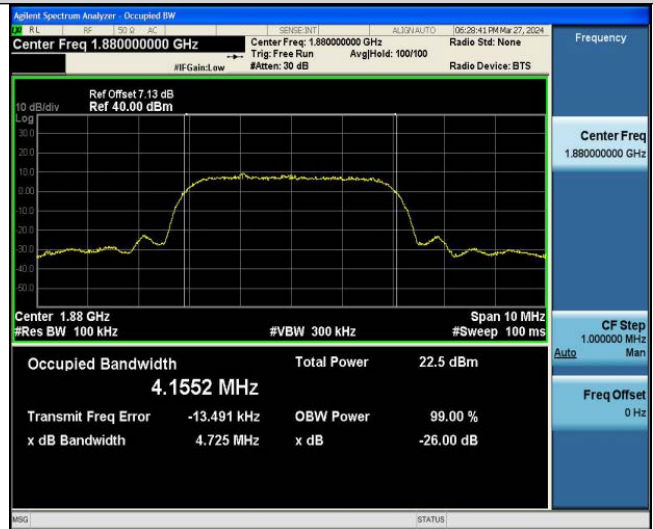

Band2-9538-1



Band2-9538-2

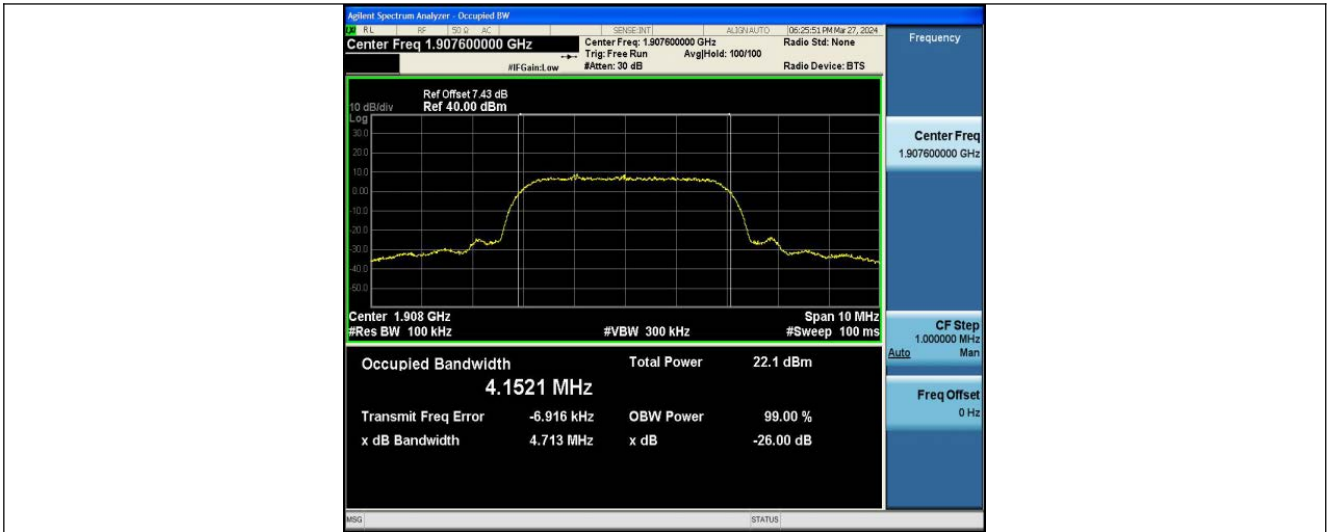

Band2-9538-3

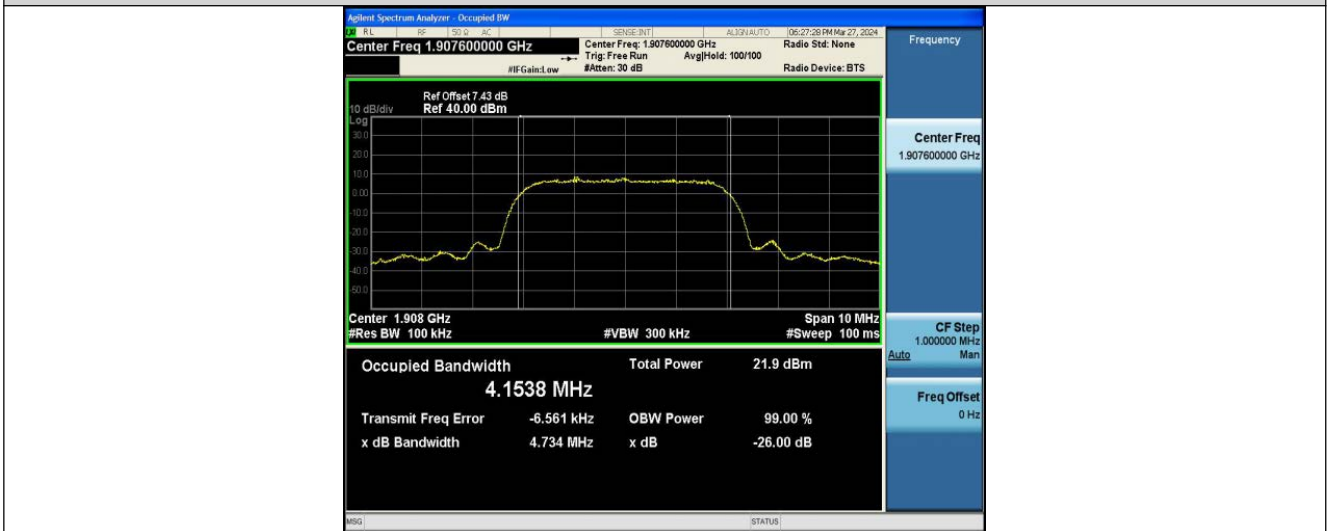

Band2-9538-4

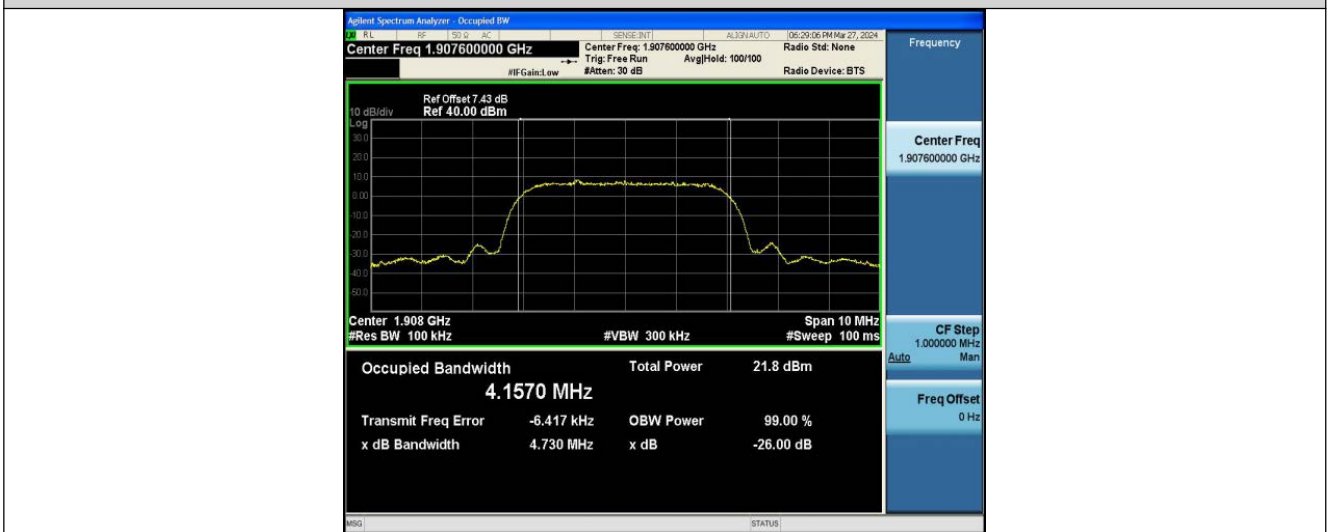

Band4-1312-1



Band4-1312-2



Band4-1312-3



Band4-1312-4



Band4-1413-1



Band4-1413-2



Band4-1413-3

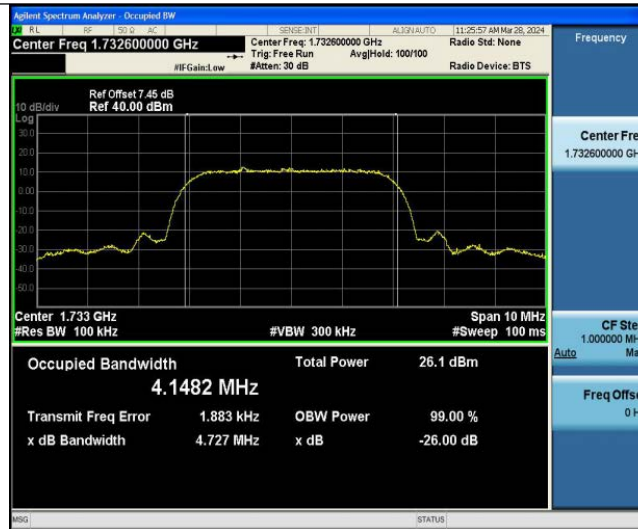

Band4-1413-4

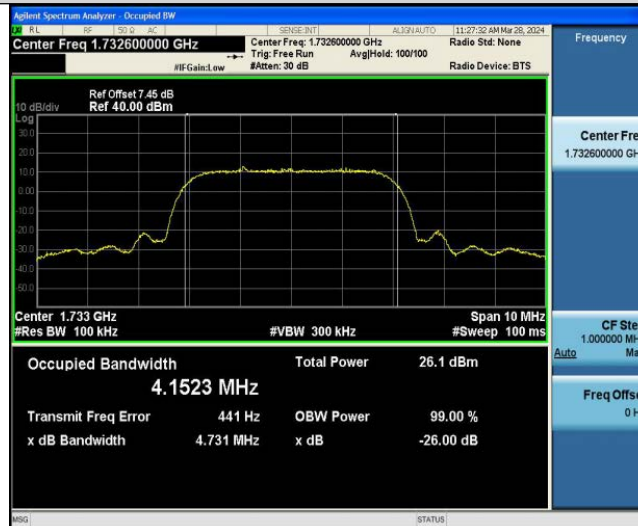

Band4-1513-1

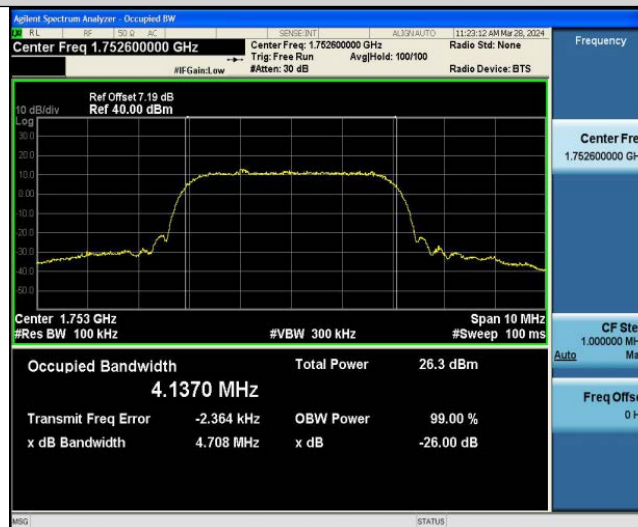

Band4-1513-2



Band4-1513-3



Band4-1513-4



Band5-4132-1



Band5-4132-2



Band5-4132-3



Band5-4132-4



Band5-4182-1

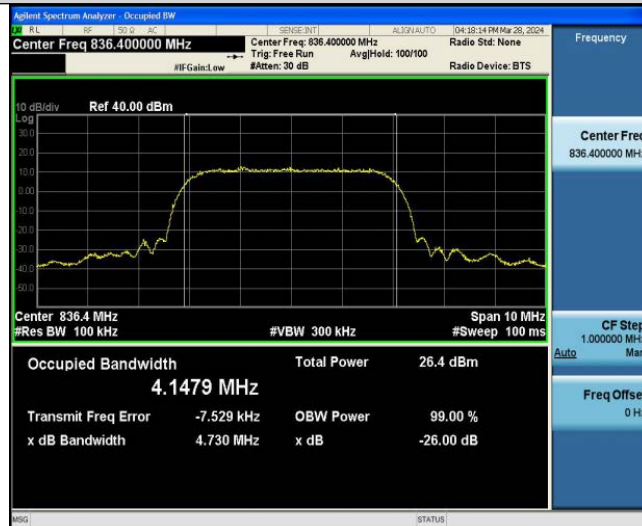

Band5-4182-2



Band5-4182-3



Band5-4182-4



Band5-4233-1



Band5-4233-2



Band5-4233-3



Band5-4233-4





Band2-9262-1



Band2-9262-2



Band2-9262-3



Band2-9262-4



Band2-9262-5

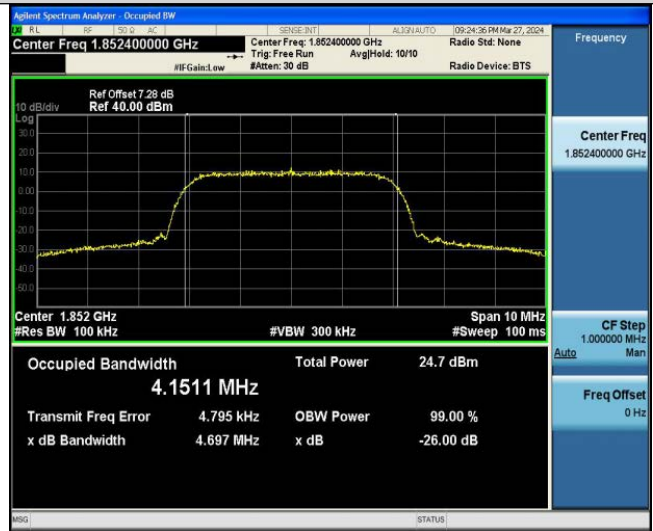

Band2-9400-1



Band2-9400-2

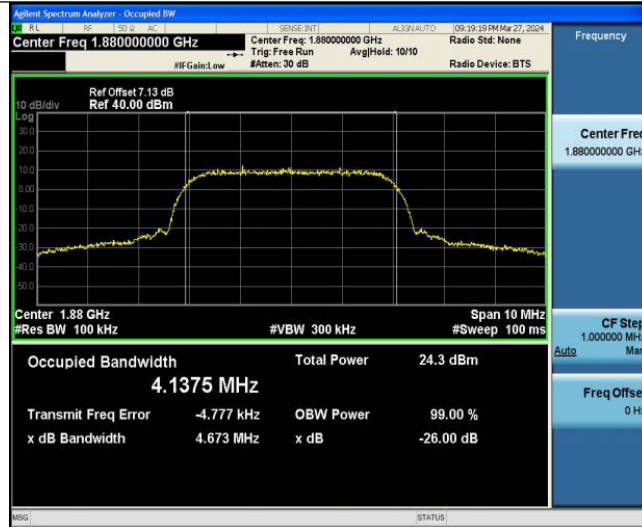

Band2-9400-3

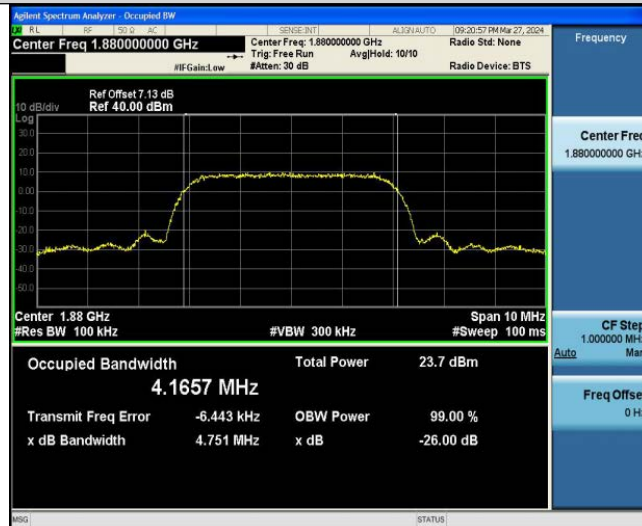

Band2-9400-4



Band2-9400-5



Band2-9538-1



Band2-9538-2



Band2-9538-3



Band2-9538-4



Band2-9538-5



Band4-1312-1



Band4-1312-2



Band4-1312-3



Band4-1312-4



Band4-1312-5



Band4-1413-1



Band4-1413-2



Band4-1413-3



Band4-1413-4



Band4-1413-5