



25.6V **BT**
100Ah (100A BMS)

Lithium Iron Phosphate Battery (LiFePO4)

PRODUCT MANUAL

PRODUCT OVERVIEW

25.6V 100AH BATTERY

Operating Voltage	25.6V
Charging Voltage	28.8±0.4V
Recommended Charge Current	20A (0.2C)
Max Continuous Discharge Current	100A
Max Continuous Output Power	2560W



ADDITIONAL COMPONENTS

M8- 5/8" (16MM) TERMINAL BOLTS

The terminal bolts are used to secure multiple cable lugs to a single battery terminal. The bolts can be replaced with M8 bolts of other lengths based on actual needs.

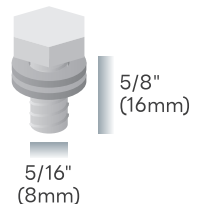

INSULATING CAPS FOR BOLTS

24/7 MONITORING VIA STARRY SEA APP

The Starry Sea 24V 100Ah Smart LiFePO4 battery, integrated with Bluetooth 5.0, enables accurate and effortless real-time tracking and management of the battery status.

STEP
1

Download the Starry Sea APP and register your account.



STEP
2

Pair the battery with the Starry Sea APP by **scanning QR code** or **searching Bluetooth** and effortlessly keep track of the battery's real-time status

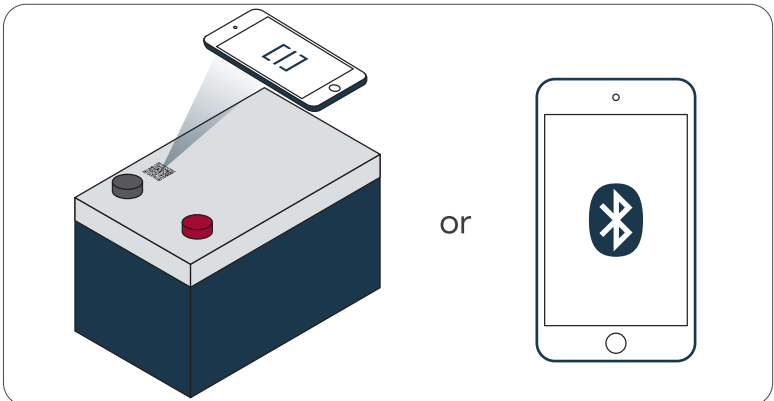

FCC STATEMENT

This device complies with Part 15 of the FCC Rules. Operation is subject to the following two conditions:

- This device may not cause harmful interference.
- This device must accept any interference received, including interference that may cause undesired operation.

This device has been tested and found to comply with the limits for a Class B digital device, pursuant to Part 15 of the FCC Rules. These limits are designed to provide reasonable protection against harmful interference in a residential installation. This device generates, uses, and can radiate radio frequency energy and, if not installed and used in accordance with the instructions, may cause harmful interference to radio communications. However, there is no guarantee that interference will not occur in a particular installation. If this device does cause harmful interference to radio or television reception, which can be determined by turning the equipment off and on, the user is encouraged to try to correct the interference by one or more of the following measures:

- Orient or relocate the receiving antenna.
- Increase the separation between the equipment and receiver.
- Connect the equipment into an outlet on a circuit different from that to which the receiver is connected.
- Consult the dealer or an experienced radio/TV technician for help.

Caution: Any changes or modifications to this device not explicitly approved by manufacturer could void your authority to operate this equipment.

This equipment complies with FCC radiation exposure limits set forth for an uncontrolled environment. This equipment should be installed and operated with minimum distance 20cm between the radiator and your body.

This transmitter must not be co-located or operating in conjunction with any other antenna or transmitter.

IMPORTANT SAFETY INSTRUCTION

- Please keep the battery away from heat sources, sparks, flames, and hazardous chemicals.

- **Maintain Adequate Ventilation and Heat Dissipation**

Place the battery in a well-ventilated area with sufficient heat dissipation to prevent overheating and damage.

- **Size the Battery Cables and Connectors Appropriately**

Use high-stranded copper connectors and heavy gauge cables to handle possible battery loads. Make sure to keep identical cable lengths.

Avoid accidents caused by unsuitable connectors or cables that make the connection a heat source during battery operation.

- Please tighten all cable connections, as loose cable connections can cause terminal meltdown or fire.

- **DO NOT puncture, drop, crush, burn, penetrate, shake, or strike the battery.**

The battery should be securely fastened during handling to prevent impact or dropping.

It should be safely secured to a solid plane and the cables safely tied to a suitable location to avoid arcing and sparking due to friction.

DO NOT press it by placing heavy stuff on top of it for long periods, which may damage it due to an internal short circuit.

- **DO NOT immerse the battery in water whether the battery is in use or on standby.**

- **DO NOT open, dismantle, or modify the battery.**

- **DO NOT touch the exposed electrolyte or powder if the battery casing is damaged.**

- **Uncovered electrolyte or powder that has contacted the skin or eyes MUST be flushed out with plenty of clean water immediately. Seek medical attention afterward.**

- **Avoid Short Circuit**

Please use circuit breakers, fuses, or disconnects that have been properly sized by certified electricians, licensed installers, or regional code authorities to protect all the electrical equipment in your system. The battery has a built-in battery management system (BMS) that protects the battery cells from over-charge, over-discharge, and over-current, however this alone will not protect your system from severe electrical conditions.

- **Trained and certified technicians are required for safe and reliable installation. This product manual can only serve as a guideline as it cannot cover all possible scenarios.**

- **Verify Correct Polarity**

Please verify the polarity before connecting the wiring. Reverse polarity can and will destroy the battery and other electrical equipment. Use a multimeter to determine proper polarity.

- **Avoid Exposed Metal Terminals or Connectors**

The terminals of this battery are always live. Avoid exposed metal terminals or connectors; DO NOT place tools on the terminals or touch them with bare hands; DO NOT short circuit or use outside of specified electrical ratings.

- **DO NOT dispose of the battery as household waste. Please use recycling channels in accordance with local, state, and federal regulations.**

WARNING

- Batteries are potentially dangerous and proper precautions must be taken during operation and maintenance.
- Improper use of the battery can lead to battery failure or other potential damage.
- Improper configuration, installation, or use of related equipment in the battery system may damage the battery and other related equipment.
- Please wear proper personal protective equipment when working on the battery.
- Battery installation and maintenance must be performed by trained and certified technicians.
- Failure to follow the warnings above can result in potential damage.

If you have any questions or need any help, please feel free to contact us (and leave your contact phone number) at service@starryseapower.com, we will offer phone or email support in 12hrs.

CONTENTS

BATTERY PARAMETERS

01

THINGS TO KNOW BEFORE USING

03

Long Term Storage

03

CHARGING METHODS

04

Solar Panel(s) & Controller

04

- Solar Panel
- Controller
- Controller Settings

Battery Charger

05

Alternator / Generator

05

HOW TO ESTIMATE THE BATTERY CAPACITY

06

State of Charge (SOC)

06

RECOMMENDED CABLE SIZING

07

SERIES / PARALLEL CONNECTION

08

The Premise of Connection

08

Limitation for Series/Parallel Connection

08

How to Connect Batteries

09

- Step 1 Wear Insulating Gloves
- Step 2 Voltage Balancing Before Connection
- Step 3 Battery-to-Battery Connection
- Step 4 Total Input & Output Connection
- Step 5 Rebalancing Every Six Months
- Wiring Diagram Reference

WHAT TO DO WHEN THE BATTERY STOPS WORKING?

13

BATTERY PARAMETERS

Cell Type	LiFePO4
Nominal Voltage	25.6V
Rated Capacity	100Ah
Energy	2560Wh
Internal Resistance	$\leq 40\text{m}\Omega$
Cycle Life	≥ 4000 times
Battery Management System (BMS) Board	100A
Charge Method	CC/CV
Charge Voltage	$28.8 \pm 0.4\text{V}$
Recommended Charge Current	20A (0.2C)
Max Continuous Charge Current	100A
Max Continuous Discharge Current	100A
Surge Discharge Current	500A@1 second
Max Continuous Output Power	2560W

Dimension	L21*W8.2*H8.5 inch
	L532*W207*H215 mm
Housing Material	ABS (Flame Retardant Plastic)
Recommended Terminal Torque	106.2 to 123.9 inch·lbs / 12 to 14 N·m
Protection Class	IP65
Temperature Range	Charge: 0°C to 50°C / 32°F to 122°F
	Discharge: -20°C to 60°C / -4°F to 140°F
	Storage: -10°C to 50°C / 14°F to 122°F
Low Temperature Charging Protection (LTCP) Function ^①	Yes
Resume Charging Temperature Under LTCP	5°C/41°F (Battery Temperature)
FCC ID	2BFF9-24100

① The 24V 100Ah Smart battery with Bluetooth supports Low Temperature Charging Protection (LTCP), where the BMS stops battery charging when the battery temperature falls below 0°C/32°F and resumes charging when the temperature rises above 5°C/41°F.

THINGS TO KNOW BEFORE USING

- When using the battery, please be careful to **avoid metal or conductive objects touching the positive and negative poles of the battery at the same time**, otherwise it may cause a short circuit.
- **Install the battery upright with post bolt facing up**, and it could not be mounted upside down. If you need to mount the battery at its side, please contact service@starryseapower.com to confirm the direction.
- **Tightly screw in the post bolts**. Having loose battery terminals will cause the terminals to build up heat resulting in damage to the battery.
- This battery is not intended to be used to start any devices, please **DO NOT use it as a starting battery**.
- Suggestions for **Long-term Storage**:

Temperature

The battery can be operated at a temperature of -20°C to 60°C / -4°F to 140°F , and a temperature between 10°C to 35°C / 50°F to 95°F is ideal for long-term storage. Store in a fireproof container and away from children.

Capacity

For a longer-lasting product, it is best to store your battery at a 50% charge level and recharge every three months if it is not going to be used for a long time.



50°F(10°C) to 95°F(35°C)

Recharge Every
3 Months

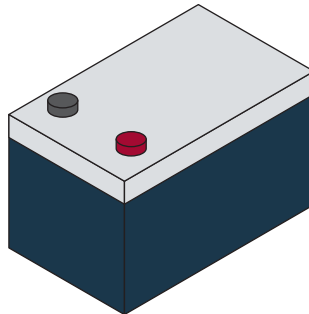

CHARGING METHODS

SOLAR PANEL(S) & CONTROLLER

● Solar Panel

Recommended Power: $\geq 800W$

- The battery can be fully charged in one day (with effective sunshine 4.5hrs/day) by 800W solar panels.
- It may take more than one day to fully charge the battery by $\geq 800W$ solar panels since the duration and intensity of light would be a great factor for their charging efficiency.

● Controller

Recommended Charging Mode: 24V (29.2V) LI (LiFePO4)

Recommended Charging Current:

- 20A (0.2C) The battery will be fully charged in around 5hrs to 100% capacity.
- 50A (0.5C) The battery will be fully charged in around 2hrs to around 97% capacity.

● Controller Settings

Refer to the below parameters if you need to manually set up your controller.

As different types of batteries have different charging modes, it is recommended to set only the following parameters for LiFePO4 batteries. The settings for other types of batteries do not apply to LiFePO4 batteries except for the following settings.

CHARGING	Charge /Bulk /Boost Voltage	28.8 \pm 0.4V
	Absorption Voltage	28.8 \pm 0.4V
	Over Voltage Disconnect	30V
	Over Voltage Reconnect	28.4V
	Tail Current	2A (0.02C)
DIS-CHARGING	Under Voltage Warning	23.2V
	Under Voltage Recover	24V
	Low Voltage Disconnect	21.6V
	Low Voltage Reconnect	24.8V

BATTERY CHARGER

Use 29.2V lithium iron phosphate (LiFePO₄) battery charger to maximize the capacity.

Recommended Charging Voltage: Between 28.4V to 29.2V

Recommended Charging Current:

- 20A (0.2C) The battery will be fully charged in around 5hrs to 100% capacity.
- 50A (0.5C) The battery will be fully charged in around 2hrs to around 97% capacity.

Tips: ① Connect the charger (with alligator clips) to the grid power before connecting it to the battery in case of sparks.

② It's recommended to disconnect the charger from the battery after fully charging.

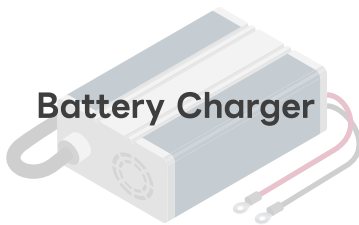

ALTERNATOR / GENERATOR

Starry Sea battery can be charged by an alternator or generator.

If the alternator/generator supports DC output, a DC-to-DC charger needs to be added between the battery and the generator; if the alternator/generator supports AC output, please refer to the recommendations in "Battery Charger" above to add a suitable battery charger between the battery and the generator.

Recommended Charging Voltage: Between 28.4V to 29.2V

Recommended Charging Current:

- 20A (0.2C) The battery will be fully charged in around 5hrs to 100% capacity.
- 50A (0.5C) The battery will be fully charged in around 2hrs to around 97% capacity.

HOW TO ESTIMATE THE BATTERY CAPACITY

STATE OF CHARGE (SOC)

The battery capacity could be roughly estimated by its resting voltage (not charging/discharging voltage)^①.

Since the voltage of each battery is slightly different, and the voltage measurement is affected by the measuring instrument, ambient temperature, etc., the following parameters are for reference only. The actual SOC of the battery is based on the discharge capacity under load.

Resting Voltage: The voltage is measured after the battery has been disconnected from the charger and loads with zero current, and left alone for 3 hours.

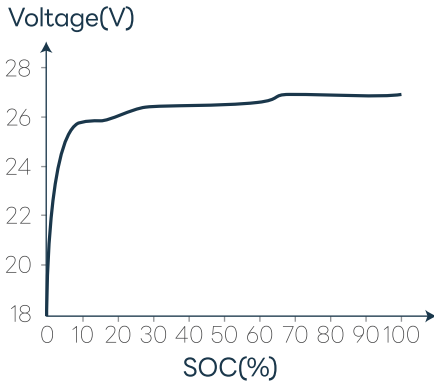

SOC (%)	Voltage (V)
0	20 to 24
25	26 to 26.3
50	26.3 to 26.4
75	26.6 to 26.66
100	≥ 26.66 ^②

① Based on the characteristics of LiFePO₄ batteries, the voltage measured by all LiFePO₄ batteries during charging/discharging is not the real voltage of the battery. Therefore, after charging/discharging and disconnecting the battery from the power source, the voltage of the battery will gradually drop/increase to its real voltage.

② After this battery is protected from overcharge, the tested battery voltage (not the real voltage) will be lower than the real voltage. To calculate the SOC (%), add 0.5V to 0.7V to the tested battery voltage.

RECOMMENDED CABLE SIZING

Battery cables should be properly sized to handle the expected load. Refer to the table below for amperage ratings for different sizes of copper cables.

PVC Copper Cable Size (AWG/mm ²)	Ampacity (A)
14 (2.08)	20
12 (3.31)	25
10 (5.25)	35
8 (8.36)	50
6 (13.3)	65
4 (21.1)	85
2 (33.6)	115
1 (42.4)	130
1/0 (53.5)	150
2/0 (67.4)	175
4/0 (107)	230

The above values are from NEC Table 310.15(B)16 for copper cables rated at 167°F (75°C) operating at an ambient temperature not exceeding 86°F (30°C). Cables longer than 6 feet (1829 mm) or ambient temperature higher than 86°F (30°C) may require heavier gauges to avoid excessive voltage drops with undersized ones.

SERIES / PARALLEL CONNECTION

THE PREMISE OF CONNECTION

To connect in series or /and parallel, batteries should meet the below conditions:

- identical batteries with the same battery capacity (Ah) and BMS (A);
- from the same brand (as lithium battery from different brands has their special BMS);
- purchased in near time (within one month).

LIMITATION FOR SERIES/PARALLEL CONNECTION

Support connecting up to 8 identical batteries for up to:

2 in series as 48V (51.2V) battery system/

4 in parallel as 400Ah battery system.

Series Connection
48V(51.2V) 100Ah

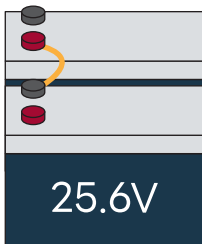

Parallel Connection
24V(25.6V) 400Ah

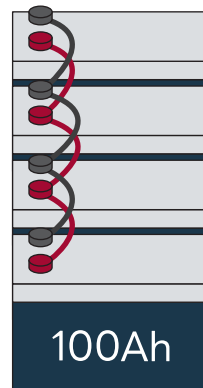

HOW TO CONNECT BATTERIES

● Step1 Wear Insulating Gloves

Wear insulating gloves for protection before connecting. Please pay attention to operation safety in the process of connection.

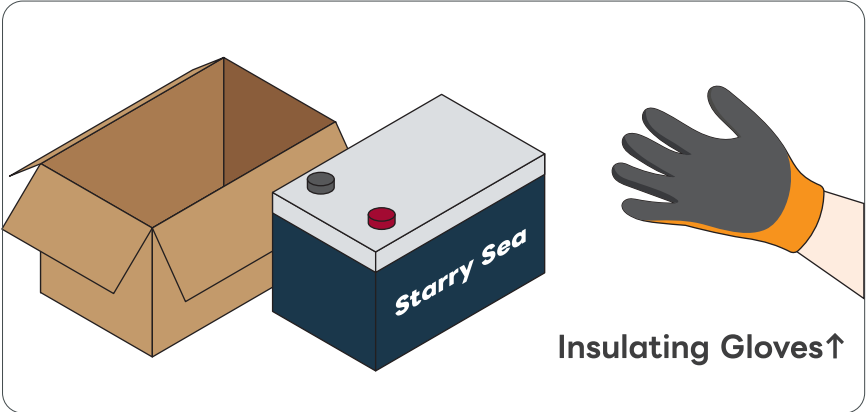

● Step2 Voltage Balancing Before Connection

Below two steps are necessary to reduce the voltage difference between batteries and let the battery system perform the best of it in series or/ and in parallel.

STEP 1 Fully charge the batteries separately.
(voltage at rest: $\cong 26.66V$)

STEP 2 Connect all of the batteries in parallel, and leave them together for 12~24hrs.

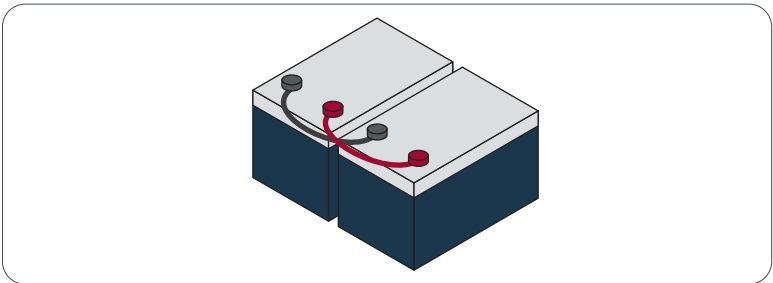

STEP 3 They're now ready for the connection.

Step 3 Battery-to-Battery Connection

#1 Connect Batteries in Series

+ to -

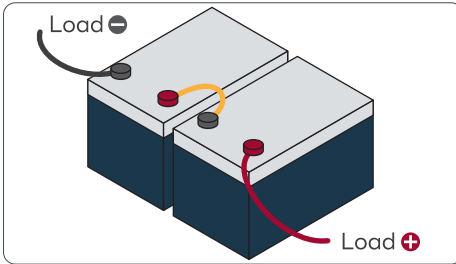

After series connection, the voltage of the battery system will be doubled according to the number of batteries you connect.

E.g. If two 24V 100Ah batteries are connected in series, the battery system will be 48V (51.2V) 100Ah.

#2 Connect Batteries in Parallel

+ to + - to -

Refer to Page 11 for total input & output connection

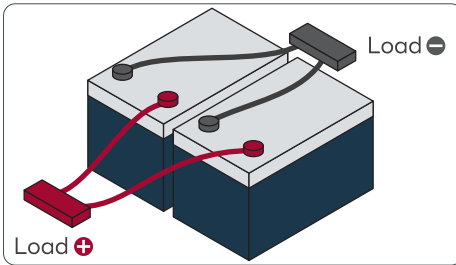

After parallel connection, the capacity of the battery system will be doubled according to the number of batteries you connect.

E.g. If two 24V 100Ah batteries are connected in parallel, the battery system will be 24V (25.6V) 200Ah.

#3 Connect Batteries Both in Series & Parallel

Connect in parallel first, then series.

STEP
1

Connect the batteries in parallel.

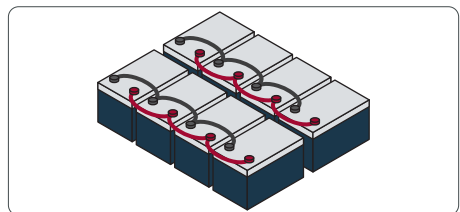

STEP
2

Connect the paralleled battery systems in series.

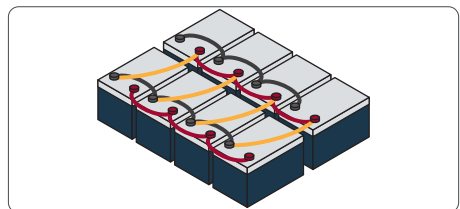

● Step4 Total Input & Output Connection

Use two copper bars (instead of battery terminals) to connect all the positive and negative output/input cables, ensuring that the input & output currents of each battery are balanced. (Not required when connecting batteries only in series.)

It is not recommended to use one terminal as the total positive or negative output/input of the battery system as the connected terminals may heat up or even melt if the total output/input current of the battery system is too high.

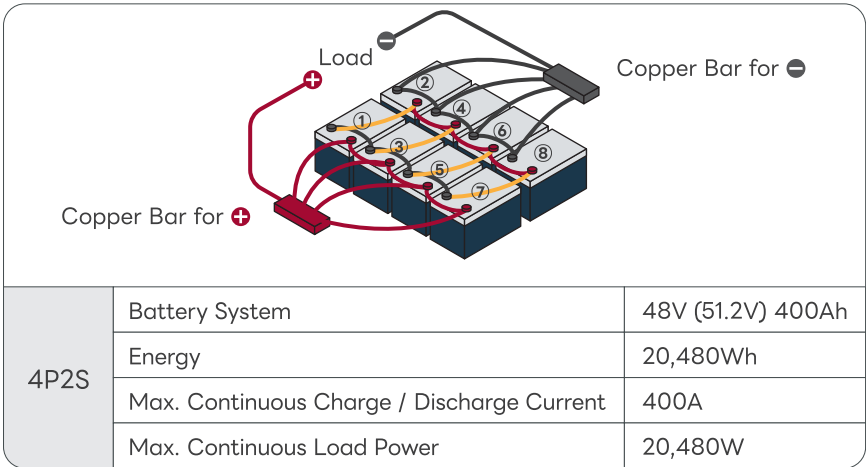

① As \ominus of ① / ③ / ⑤ / ⑦ is connected in series with \oplus of ② / ④ / ⑥ / ⑧, please do not connect \ominus of ① / ③ / ⑤ / ⑦ with \ominus of load or \oplus of ② / ④ / ⑥ / ⑧ with \oplus of load, otherwise the battery system will fail to connect in series.

② Please do not connect in reverse order, which may affect the use of the batteries.

● Step 5 Rebalancing Every 6 Months

It is recommended to rebalance the battery voltage every six months following Step 2 on Page 9 if you're connecting multiple batteries as a battery system, as there might be voltage differences after six months of the battery system running.

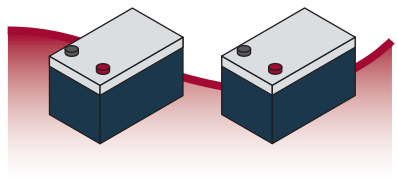

● Wiring Diagrams

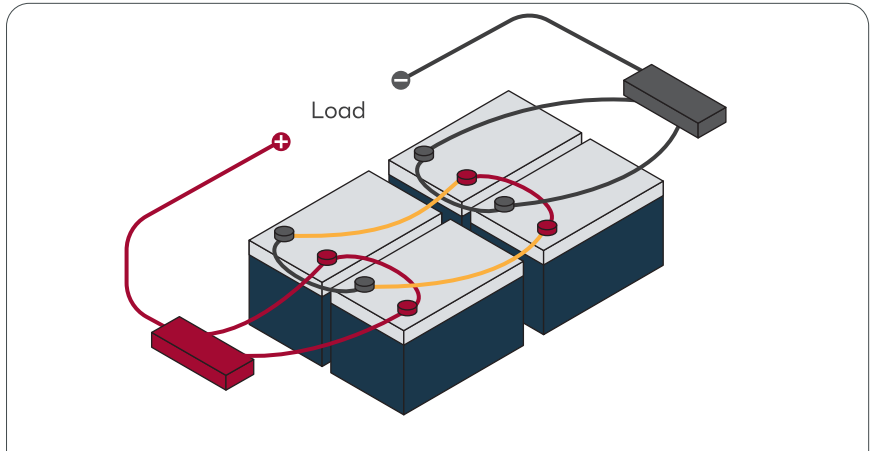

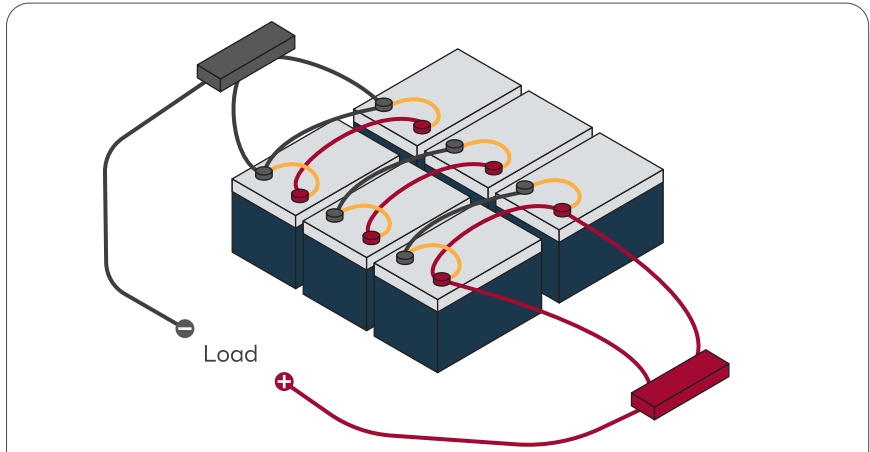

2P2S	Battery System	48V (51.2V) 200Ah
	Energy	10,240Wh
	Max. Continuous Charge / Discharge Current	200A
	Max. Continuous Load Power	10,240W



3P2S	Battery System	48V (51.2V) 300Ah
	Energy	15,360Wh
	Max. Continuous Charge / Discharge Current	300A
	Max. Continuous Load Power	15,360W

WHAT TO DO WHEN THE BATTERY STOPS WORKING?

When the battery		
 Can't work	 Can't be charged	 Voltage < 18v

It has 85% chances that BMS has shut it off for protection, and you could try one of below ways to activate the battery.

GENERAL STEPS

If the BMS has cut off the battery for protection, follow the below steps to activate it.

STEP 1 Cut off all the connections from the battery

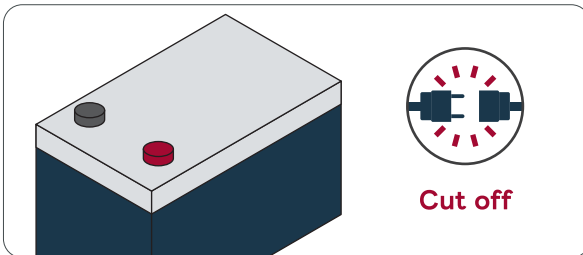

STEP 2 Leave the battery aside for 30mins
Then the battery will automatically recover itself to normal voltage (>20V) and can be used after fully charged.

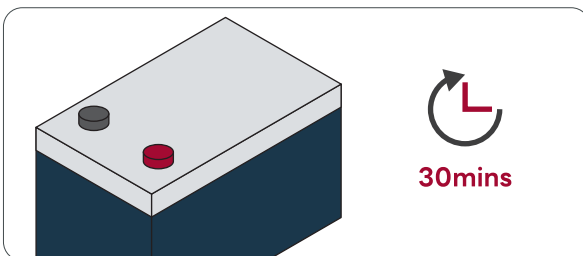

If the battery is unable to recover itself after the above steps, please try activating by **ONE OF BELOW TWO METHODS**.

After activated (voltage > 20V) and fully charged by the normal charging method, it can be used normally.

METHOD ①

Use a charger with lithium battery activation function to fully charge the battery.

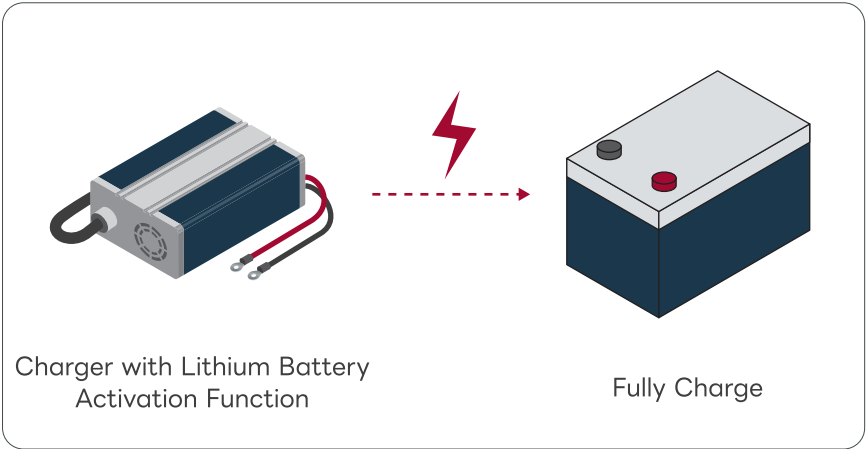

METHOD ②

Connect a controller that supports 24V LiFePO4 battery charging to charge the battery for 3~10s in sunny daytime.

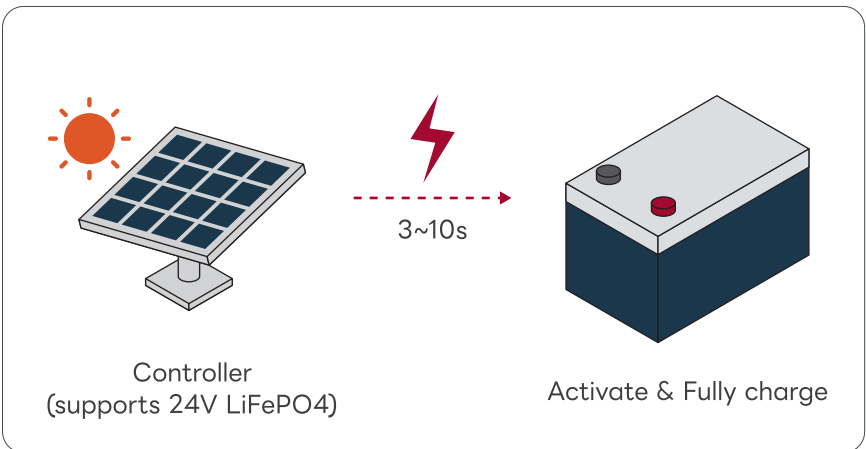



www.starryseapower.com



STARRYSEA CO., LIMITED

 service@starryseapower.com