

HT60

1080p Wi-Fi Light Bulb Security Camera

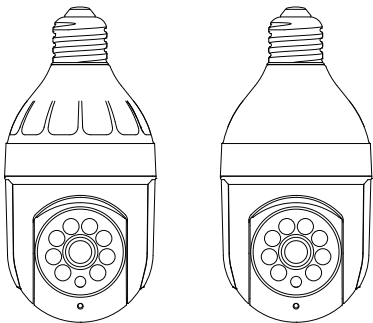

Scan the code to
view the user manual

Features

1. White Lights

4. Light Sensor

7. Setup Button

2. Wide-angle Lens

5. Microphone

8. USB Port

3. IR LED

6. Speaker

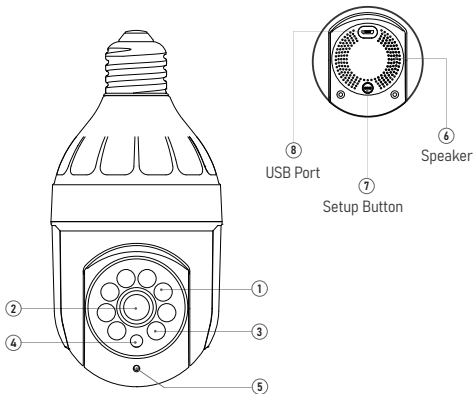

Create an account in the Kement app

1. Scan the QR code provided or search for Kement in the Apple App Store or Google Play. Then download and install the app.



Android/iOS App Download

2. Open the Kement app on your cellphone and tap Sign up.

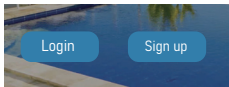

3. Enter your email address, set a password, and tap Sign up.

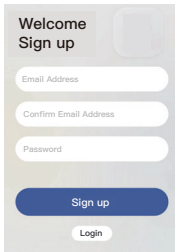

Welcome
Sign up

Email Address

Confirm Email Address

Password

Sign up

Login

4. After activating your account with the email link, log in to the app using your email and password.

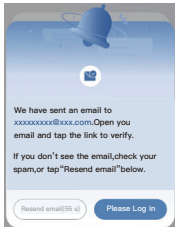

5. Re-open the Kement app, enter your email address and password, and tap Log in.

Set Up Your Light Bulb Camera in the Kement App

1. Screw the bulb camera into the light socket. (Input Voltage: 110-240V)
2. When your camera is not connected to your **2.4G Wi-Fi**, the LED lights will flash.
3. Open the **Kement app** and sign in to your account.
4. To add your camera, tap the **Add device icon (+)**.
5. Enable your phone's **Bluetooth**  .
6. Select **IPC Camera** and choose model **HT60/HT50**.

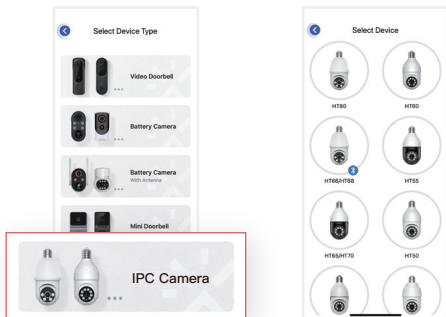

7. Press and hold the setup button on the back of the camera for 8 seconds. Once you hear Entering pairing mode, tap Yes.

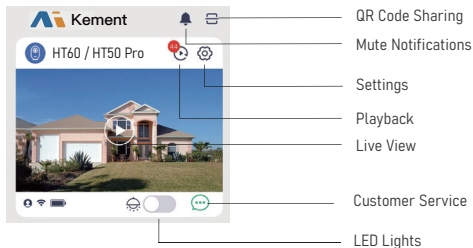

8. The device supports only the 2.4GHz Wi-Fi network. Navigate to your cellphone's Wi-Fi settings, connect to a 2.4GHz Wi-Fi network, and tap "Yes." (Note: 5GHz Wi-Fi is not supported).
9. For Connection Setup: Select your 2.4GHz Wi-Fi network name, input the password.
10. Tap Confirm.
11. Use the device's camera to scan the QR code on your phone.
12. Once you hear Device registration successful, you are all set.

Quick Guide to the App



Frequently asked questions

1. How can I share the device with family members?

Open the Kement app and tap on Settings . From there, you can share  the device via QR code or email, and even transfer ownership of the device. The new user must first download the Kement app and create their own account.

2. Why can't I change the settings?

Only the owner account  can change settings, delete videos, and share the device. Shared accounts do not have these options.

3. How many users can view the device at the same time?

The owner account can share the device with up to 8 other accounts. Up to 3 users may view the video feed at once, but only 1 user can use the intercom.

4. Is the 5GHz Wi-Fi supported?

No, the camera only works with 2.4GHz Wi-Fi. Please separate two Wi-Fi bands by giving the 2.4 GHz and 5 GHz networks each a unique separate SSID (network name). Then connect your device to the 2.4GHz Wi-Fi.

5. Why is my Wi-Fi signal weak?

Your camera may be too far from your wireless router, or there may be obstructions reducing signal strength. You might want to reposition your router or get a signal extender/repeater.

6. Why is the camera offline?

The camera being offline means it is disconnected. There could be a few reasons for this:

- 1) The Wi-Fi signal is weak, causing disconnection. Please improve your Wi-Fi signal and reconnect the device.
- 2) If the Wi-Fi is unstable, the device might go offline or experience interruptions frequently. You can try restarting the router and reconnecting the Wi-Fi to see if it helps. A good Wi-Fi connection is essential since the device is outside the house.

7. How can I adjust the human detection accuracy?

Open the Kement app and tap on Settings. password, tap on Motion Settings. Here, you can select the desired human detection accuracy from three options: low, medium, and high. We recommend choosing medium. The high setting provides the strictest detection level, meaning the device will be triggered only when it is entirely certain that the moving object is a human. However, this stringent setting might cause the device to overlook a human figure, resulting in a missed notification.

High Accuracy - The device will record videos less frequently, ensuring maximum battery life.

Medium Accuracy - Medium battery life.

Low Accuracy - The device will record videos more frequently, leading to the shortest battery life.

If the areas you're monitoring experience excessive or repetitive motions, like children playing in the yard, you may receive numerous alerts, which can rapidly deplete the battery of devices. The human detection accuracy settings are designed to help you receive the notifications you want while preserving battery life.

8. How can I enable notifications on my phone?

- 1) Open the Kement app. From the Device page, tap the Settings icon, then tap the Motion Detection icon. Here, you can choose whether to turn Motion Alerts on or off.
- 2) Open your phone's settings. Navigate to "App Management" and "Notification Settings," then locate the Kement app. Ensure all permissions and notifications are enabled for the Kement app.

Contact us

If you require further assistance, feel free to reach out to our support team. Use the Kement app's support feature. Please include your product's model and the retailer's name. Thank you.

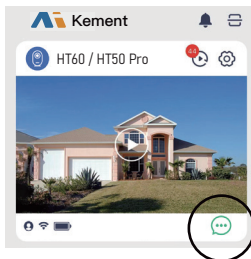
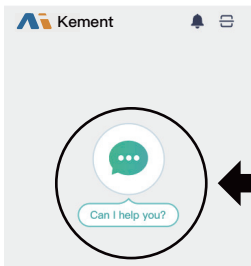

FCC Statement

Changes or modifications not expressly approved by the party responsible for compliance could void the user's authority to operate the equipment. This equipment has been tested and found to comply with the limits for a Class B digital device, pursuant to Part 15 of the FCC Rules. These limits are designed to provide reasonable protection against harmful interference in a residential installation. This equipment generates uses and can radiate radio frequency energy and, if not installed and used in accordance with the instructions, may cause harmful interference to radio communications. However, there is no guarantee that interference will not occur in a particular installation. If this equipment does cause harmful interference to radio or television reception, which can be determined by turning the equipment off and on, the user is encouraged to try to correct the interference by one or more of the following measures:

- Reorient or relocate the receiving antenna.
 - Increase the separation between the equipment and receiver.
 - Connect the equipment into an outlet on a circuit different from that to which the receiver is connected.
 - Consult the dealer or an experienced radio/TV technician for help
- This device complies with part 15 of the FCC rules. Operation is subject to the following two conditions (1) this device may not cause harmful interference, and (2) this device must accept any interference received, including interference that may cause undesired operation.

This equipment complies with FCC radiation exposure limits set forth for an uncontrolled environment. This equipment should be installed and operated with minimum distance 20cm between the radiator & your body.