



User's Manual



Professional

MPPT MAX PV Input Voltage 200V

SOLAR CHARGE CONTROLLER
12/24/48V 60A 80A 100A

Dear users,

Thank you for choosing our product !

Important Safety Instructions

Please keep this manual for future review.

This manual contains all instructions of safety, installation and operation for Tracer Dream 200V series Maximum Power Point Tracking (MPPT) controller ("the controller" as referred to in this manual).

General Safety Information

- ① Read carefully all the instructions and warnings in the manual before installation.
- ② No user serviceable components inside the controller. Don't disassemble or attempt to repair the controller.
- ③ Mount the controller indoors. Avoid exposure the components and do not allow water to enter the controller.
- ④ Install the controller in a well ventilated place. The controller's heat sink may become very hot during operation.
- ⑤ Suggest installing appropriate external fuses/breakers.
- ⑥ Make sure to switch off all PV array connections and the battery fuse or breakers before controller installation and adjustment.
- ⑦ Power connections must remain tight to avoid excessive heating from loose connection.

Explanation of symbols

- To enable users to use the product efficiently and ensure personal and property safety, please read related literature accompanying the following symbols.
- Please read the literature accompanying the following symbols.

Tips: Indicate recommendations that can be referred to.



IMPORTANT: Indicates a critical tip during the operation, if ignored, may cause the device to run in error.



CAUTION: Indicates potential hazards, if not avoided, may cause the device damaged.



WARNING: Indicates the danger of electric shock; if not avoided, it would cause casualties.

1. General Information

1.1 Overview

Tracer Dream 200V Series controller is based on Multi phase synchronous rectification technology and advanced MPPT control algorithm, adopt co-negative design, with LCD displaying running status. The MPPT control algorithm can minimize the maximum power point loss rate and loss time, quickly track the maximum power point of the PV array and obtain the maximum energy from solar modules under any conditions; and can increase the ratio of energy utilization in the solar system by 20%-30% compared with a PWM charging method.

The Tracer Dream 200V Series controller owns a self-adaptive three-stage charging mode based on a digital control circuit. This function can effectively prolong the battery's lifespan and significantly improve the system's performance.

Limiting the charging power and reducing charging power functions ensure the system stable with over PV modules in high temperature environment.

With comprehensive electronic fault self-detecting functions and powerful electronic protection functions built inside the controller, component damage caused by installation errors or system failures can be avoided to the greatest extent possible.

The utility/generator dry contact to connect external devices conveniently composes a hybrid power system easily.

The isolated RS485 port with standard MODBUS communication protocol and 5V power supply is easy to expand the application and connect the external Bluetooth/WiFi module. The controller can be widely used for various applications, e.g., solar RV, household system and field monitoring, etc.

Features:

- With the advanced dual-peak or multi-peak tracking technology, when the solar panel is shadowed or part of the panel fails resulting in multiple peaks on the I-V curve, the controller is still able to accurately track the maximum power point.
- Advanced MPPT technology, with efficiency no less than 99.5%
- Maximum DC/DC conversion efficiency of 98%
- Ultra-fast tracking speed and guaranteed tracking efficiency
- Advanced MPPT control algorithm to minimize the MPP loss rate and loss time
- Wide MPP operating voltage range
- Limit charging power & current over rated range. When the solar panel power exceeds a certain level and the charging current is larger than the rated current, the controller will automatically lower the charging power and bring the charging current to the rated level.
- Support the lead-acid, gel, flooded with the needed Temp. compensation and support lithium batteries starting from solar panel
- Real-time working record function
- Load dry contact to control the external load switch
- Auto-control of utility and generator dry contact design to compose a hybrid power system easily
- Power reduction automatically over temperature range
- TVS lightning protection.
- Support parameters setting via the iConnect App

1.2 Characteristics

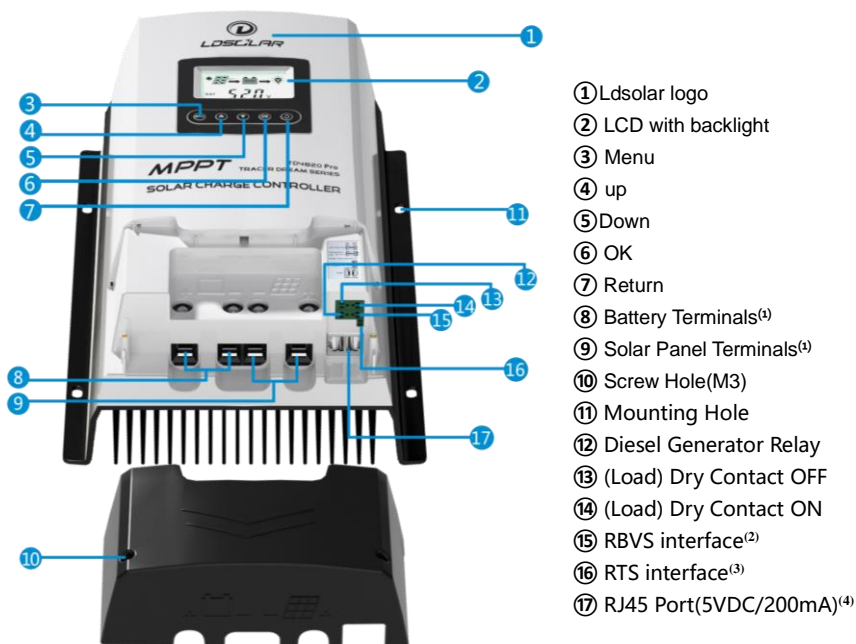
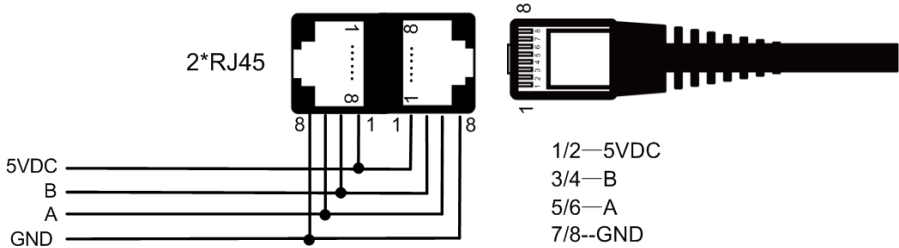

Figure 1-1 Product Characteristics

- (1) The controller is designed with a common negative polarity. The negative polarity of the PV and the battery is located on the same busbar.
 - (2) Connect an RBVS (Remote Battery Voltage Sensor) to detect accurate battery voltage. The sampling distance is no longer than 20m.
 - (3) Connect an RTS (Remote Temperature Sensor) to remotely detect the battery temperature. The sampling distance is no longer than 20m.
- ★If the temperature sensor is short-circuited or damaged, the controller will charge at the default temperature setting of 25°C.(no temperature compensation)
- (4) When connecting the controller to external devices,only one of the RJ45 port can be used.when connecting multiple controller in parallel,RJ45 port are for cascade use.



1.3 Naming Rules of Controller models

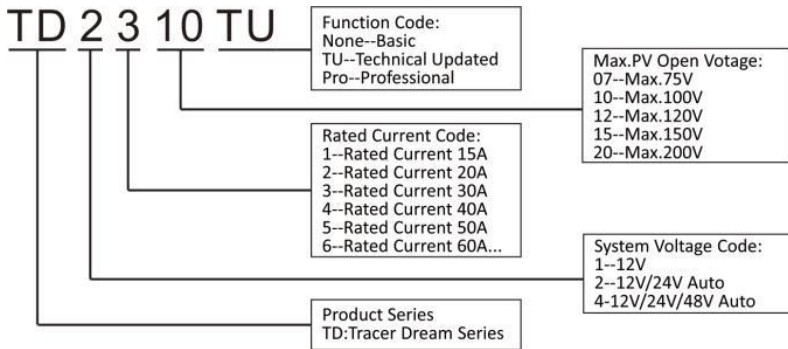

Figure 1-2 Example

1.4 Maximum Power Point Tracking Technology

Due to the nonlinear characteristics of solar array, there is a maximum energy output point (Max Power Point) on its curve. Traditional controllers, with switch charging technology and PWM charging technology, can't charge the battery at the maximum power point, so can't harvest the maximum energy available from PV array, but the solar charge controller with Maximum

Power Point Tracking (MPPT) Technology can lock on the point to harvest the maximum energy and deliver it to the battery.

The MPPT algorithm of our company continuously compares and adjusts the operating points to attempt to locate the maximum power point of the array. The tracking process is fully automatic and does not need user adjustment.

As the Figure 1-2, the curve is also the characteristic curve of the array, the MPPT technology will 'boost' the battery charge current through tracking the MPP. Assuming 100% conversion efficiency of the solar system, in that way, the following formula is established:

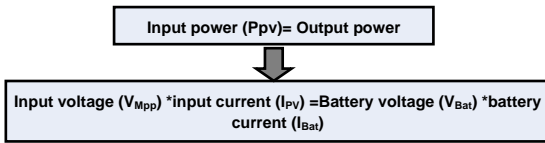

Normally, the V_{Mpp} is always higher than V_{Bat}, Due to the principle of conservation of energy, the I_{Bat} is always higher than I_{PV}. The greater the discrepancy between V_{Mpp} & V_{Bat}, the greater the discrepancy between I_{PV} & I_{Bat}. The greater the discrepancy between array and battery, the bigger reduction of the conversion efficiency of the system, thus the controller's conversion efficiency is particularly important in the PV system.

Figure 1-3 is the maximum power point curve, the shaded area is charging range of traditional solar charge controller (PWM Charging Mode), it can obviously diagnose that the MPPT mode can improve the usage of the solar energy resource. According to our test, the MPPT controller can raise 20%-30% efficiency compared to the PWM controller. (Value may be fluctuant due to the influence of the ambient circumstance and energy loss.)

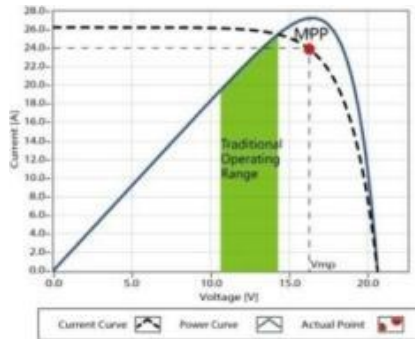

Figure 1-3 Maximum Power Point Curve

In actual application, as shading from cloud, tree and snow, the panel maybe appear Multi-MPP, but in actually there is only one real Maximum Power Point. As the below Figure 1-3 shows:

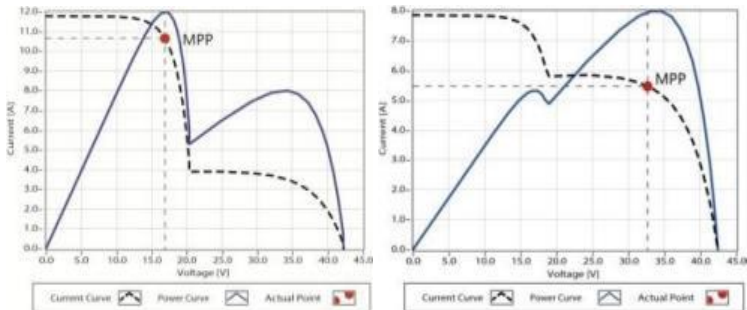

Figure 1-4 Mutil-MPP Curve

If the program works improperly after appearing Multi-MPP, the system will not work on the real max power point, which may waste most solar energy resources and seriously affect the normal operation of the system. The typical MPPT algorithm, designed by our company, can track the real MPP quickly and accurately, improve the utilization rate of the array and avoid the waste of resources.

1.5 Battery Charging Stage

The controller has a 3 stages battery charging algorithm (Bulk Charging, Boost Charging and Float Charging) for rapid, efficient, and safe battery charging.

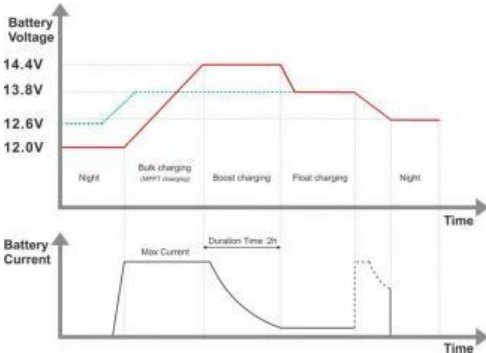

Figure 1-5 Lead acid Battery charging stage Curve

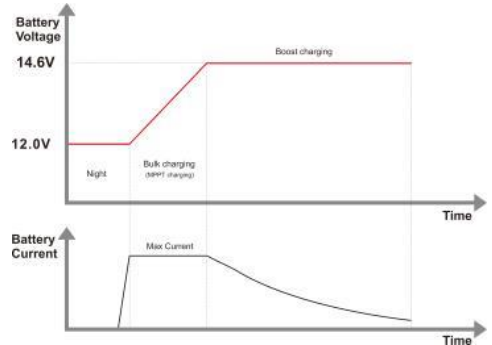

Figure 1-6 Li Battery charging stage curve

(1) Bulk Charging

In this stage, the battery voltage has not yet reached boost voltage, the controller operates in constant current mode, delivering its maximum current to the batteries (MPPT Charging).

(2) Boost Charging

When the battery voltage reaches the boost voltage set point, the controller will start to operate in constant charging mode, this process is no longer MPPT charging, and in the meantime the charging current will drop gradually, the process is not the MPPT charging. The Boost stage maintain 2 hours in default. When the accumulate time reach to 2hours, the charging mode will turn to Float charging.

(3) Float Charging

After the boost voltage stage, the controller will reduce charging current to Float Voltage set point. This stage will have no more chemical reactions and all the charge current transforms into heat and gas at this time. Then the controller reduces the voltage to the floating stage, charging with a smaller voltage and current. It will reduce the temperature of the battery and prevent the gassing and charging the battery slightly at the same time. The purpose of Float stage is to offset the power consumption caused by self consumption and small loads in the whole system, while maintaining full battery storage capacity.

In Float charging stage, loads are able to obtain almost all power from solar panel. If loads exceed the power, the controller will no longer be able to maintain battery voltage in Float charging stage. If the battery voltage remains below the Recharge Voltage, the system will leave Float charging stage and return to Bulk charging stage.

1.6 Included accessories

No.	accessories	Instruction	Quantity	Picture
1	Remote Temperature Sensor	the standard length of the cable is 1M. 2P-3.5mm	1 pc	
2	Dry Contact Terminal	2P-3.81mm	2 pc	
3	Bluetooth Module	External bluetooth module (CM-B01)with1M RJ45 cable	1pc	



The above-included accessories are packed in a plastic bag and a box, Please check after opening the package.

The manufacturer may adjust the standard Bluetooth module without prior notice.



Do not insert the same model terminals into different interfaces. Otherwise, the controller will be damaged.

2 Installation Instructions

2.1 General Installation Notes

- Please read the entire installation instructions to get familiar with the installation steps before installation.
- Be very careful when installing the batteries, especially flooded lead-acid battery. Please wear eye protection, and have fresh water available to wash and clean any contact with battery acid.
- Keep the battery away from any metal objects, which may cause short circuit of the battery.
- Explosive battery gases may come out from the battery during charging, so make sure ventilation condition is good.
- Ventilation is highly recommended if mounted in an enclosure. Never install the controller in a sealed enclosure with flooded batteries! Battery fumes from vented batteries will corrode and destroy the controller circuits.
- Loose power connections and corroded wires may result in high heat that can melt wire insulation, burn surrounding materials, or even cause fire. Ensure tight connections and use cable clamps to secure cables and prevent them from swaying in mobile applications.
- Lead-acid battery and lithium battery are recommended, other kinds please refer to the battery manufacturer.
- Battery connection may be wired to one battery or a bank of batteries. The following instructions refer to a singular battery, but it is implied that the battery connection can be made to either one battery or a group of batteries in a battery bank.
- Multiple same models of controllers can be installed in parallel on the same battery bank to achieve higher charging current. Each controller must have its own solar module(s).
- When selecting connection wires for the system, follow the criterion that the current density is not larger than $5A/mm^2$.

2.2 PV Array Requirements

(1) Serial connection (string) of PV modules

As the core component of PV system, controller could be suitable for various types of PV modules and maximize converting solar energy into electrical energy. According to the open circuit voltage (V_{oc}) and the maximum power point voltage (V_{Mpp}) of the MPPT controller, the series number of different types PV modules

can be calculated. The below table is for reference only.

Table 2-1 TD4620Pro/TD4820Pro/TD41020Pro

System voltage	36 cell Voc < 23V		48 cell Voc < 31V		54 cell Voc < 34V		60 cell Voc < 38V	
	Max.	Best	Max.	Best	Max.	Best	Max.	Best
12V	4	2	3	1	2	1	2	1
24V	6	3	4	2	4	2	3	2
48V	8	5	5	4	5	3	4	3

System voltage	72 cell Voc < 46V		96 cell Voc < 62V		Thin-Film Module Voc > 80V
	Max.	Best	Max.	Best	
12V	2	1	1	1	1
24V	3	2	2	1	1
48V	4	3	2	2	2

NOTE: The above parameter values are calculated under standard test conditions (STC (Standard Test Condition): Irradiance 1000W/m², Module Temperature 25°C, Air Mass1.5.)

(2) Maximum PV array power

The MPPT controller has the function of current/power-limiting, that is, during the charging process, when the charging current or power exceeds the rated charging current or power, the controller will automatically limit the charging current or power to the rated charging current or power, which can effectively protect the charging parts of controller, and prevent damages to the controller due to the connection of some over-specification PV modules. The actual operation of PV array is as follows:

Condition 1:

Actual charging power of PV array ≤ Rated charging power of controller

Condition 2:

Actual charging current of PV array ≤ Rated charging current of controller

When the controller operates under "Condition 1" or "Condition 2", it will carry out the charging as per the actual current or power; at this time, the controller can work at the maximum power point of PV array.

⚠WARNING: When the power of PV is not greater than the rated charging power, but the maximum open-circuit voltage of PV array is more than 200V(at the lowest environmental temperature), the controller may be damaged.

Condition 3:

Actual charging power of PV array > Rated charging power of controller

Condition 4:

Actual charging current of PV array > Rated charging current of controller

When the controller operates under "Condition 3" or "Condition 4", it will carry out the charging as per the rated current or power.

⚠WARNING: When the power of PV module is greater than the rated charging power, and the maximum open-circuit voltage of PV array is more than 200V(at the lowest environmental temperature), the controller may be damaged.

According to "Peak Sun Hours diagram", if the power of PV array exceeds the rated charging power of controller, then the charging time as per the rated power will be prolonged, so that more energy can be obtained for charging the battery. However, in the practical application, the maximum power of PV array shall be not greater than 1.5 x the rated charging power of controller. If the maximum power of PV array exceeds the rated charging power of controller too much, it will not only cause the waste of PV modules, but also increase the open-circuit voltage of PV array due to the influence of environmental temperature, which may make the probability of damage to the controller rise. Therefore, it is very important to configure the

system reasonably. For the recommended maximum power of PV array for this controller, please refer to the table below:

Table 2-2 maximum power of PV array for this controller

Model	Rated Charge Current	Rated Charge Power	Max. PV Array Power	Max. PV open circuit voltage
TD4620Pro	60A	800W/12V 1600W/24V 3200W/48V	1200W/12V 2400W/24V 4800W/48V	180V(25°C) 200V(Lowest temperature)
TD4820Pro	80A	1000W/12V 2100W/24V 4200W/48V	1500W/12V 3150W/24V 6300W/48V	
TD41020Pro	100A	1300W/12V 2600W/24V 5200W/48V	19500W/12V 3900W/24V 7800W/48V	

2.3 Wire Size

The wiring and installation methods must conform to all national and local electrical code requirements.

PV Wire Size

Since PV array output can vary due to the PV module size, connection method or sunlight angle, the minimum wire size can be calculated by the I_{sc} * of PV array. Please refer to the value of I_{sc} in the PV module specification. When PV modules connect in series, the I_{sc} is equal to a PV modules I_{sc} . When PV modules connect in parallel, the I_{sc} is equal to the sum of the PV module's I_{sc} . The I_{sc} of the PV array must not exceed the controller's maximum PV input current. Please refer to the table as below:

NOTE: All PV modules in a given array are assumed to be identical.

* I_{sc} =short circuit current(amps) V_{oc} =open circuit voltage.

Table 2-3 PV array must not exceed the controller's maximum

Model	Max.battery wire size	Max. PV wire size *
TD4620Pro	25mm ² /4AWG	25mm ² /4AWG
TD4820Pro	35mm ² /2AWG	35mm ² /2AWG
TD41020Pro	35mm ² /2AWG	35mm ² /2AWG

* These are the maximum wire sizes that will fit the controller terminal

-  ① The wire size is only for reference. Suppose a long-distance exists between the PV array and the controller or between the controller and the battery. In that case, larger wires shall be used to reduce the voltage drop and improve the system performance.
- ② The recommended wire for the battery that its terminals are not connected to any additional inverter.

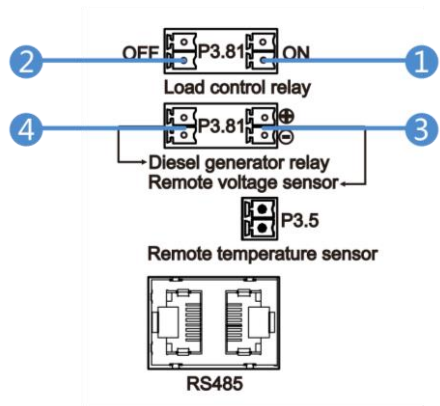
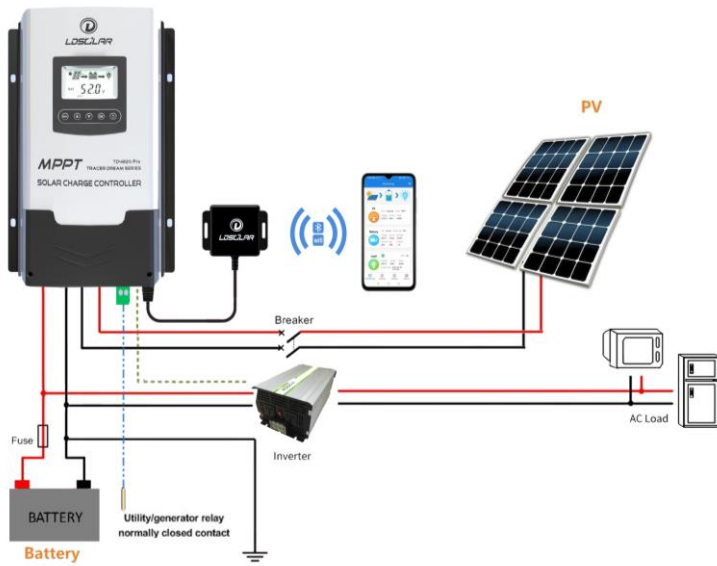

2.4 Dry Contact Instruction

Dry contact parameter

Rated Value: 3A/30VDC

Maximum Value: 0.5A/60VDC

Battery Voltage (V_{BAT})

Low Voltage Disconnect Voltage (V_{LVD})

Low Voltage Reconnect Voltage (V_{LVR})

- ① $V_{BAT} < V_{LVD}$: The dry contact controls the load to connect
- ② $V_{BAT} < V_{LVD}$: The dry contact controls the load to disconnect
- ③ Connect an RBVS (Remote Battery Voltage Sensor) to detect accurate battery voltage. The sampling distance is no longer than 20m.
- ④ $V_{BAT} < V_{LVD}$: The dry contact controls the diesel generator to start

2.5 Mounting

⚠Warning: risk of explosion! Never install the controller and an open battery in the same enclosed space! Nor shall the controller be installed in an enclosed space where battery gas may accumulate.

⚠Warning: danger of high voltage! Photovoltaic arrays may produce a very high open-circuit voltage. Open the breaker or fuse before wiring, and be very careful during the wiring process.

Note: when installing the controller, make sure that enough air flows through the controller's radiator, and leave at least 100mm of space both above and below the controller so as to ensure natural convection for heat dissipation. If the controller is installed in an enclosed box, make sure the box delivers reliable heat dissipation effect.

2.5 Installation Procedure

Step 1: choose the installation site

Do not install the controller at a place that is subject to direct sunlight, high temperature or water intrusion, and make sure the ambient environment is well ventilated.

Step 2: Place the controller at a proper position, use a screw driver to fit screws in mounting hole.

⚠CAUTION: If the controller is to be installed in an enclosed box, it is important to ensure reliable heat dissipation through the box.

Step 3: wire

Connect the system in the order of ①battery ② PV array in accordance with Figure 2-2, "Schematic Wiring Diagram". and disconnect the system in the reverse order ②①

①Single controller

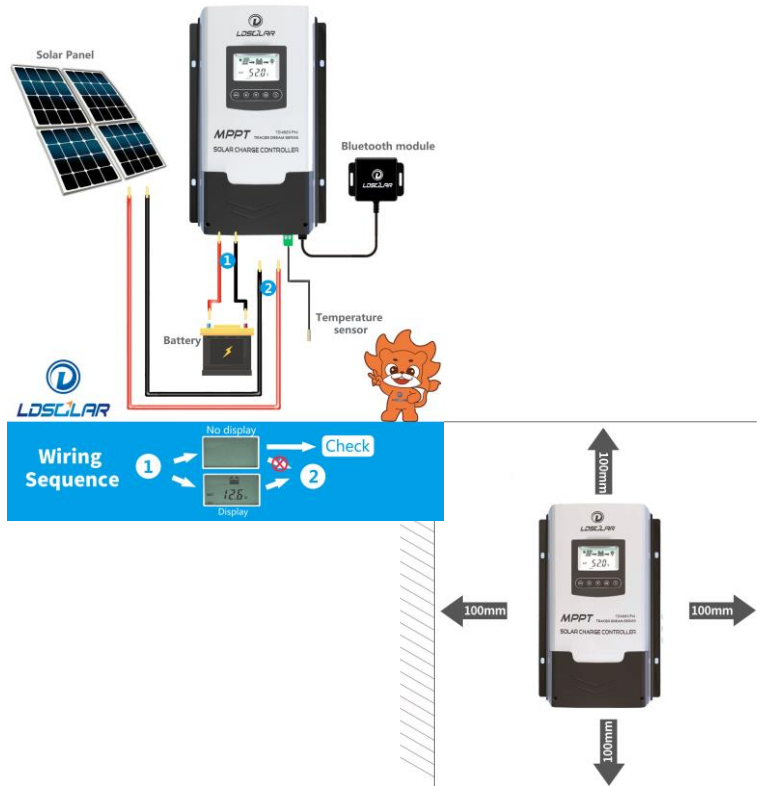

②Connection in parallel

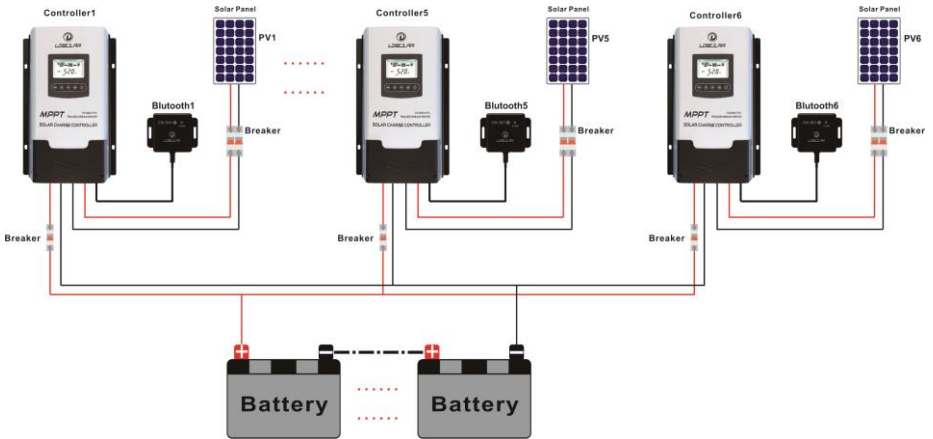

Figure 2-2 Schematic of wiring diagram

⚠CAUTION: While wiring the controller do not close the circuit breaker or fuse and make sure that the leads of "+" and "-" poles are connected correctly.

⚠CAUTION: A fuse which current is 1.25 to 2 times the rated current of the controller, must be installed on the battery side with a distance from the battery not greater than 150 mm.

⚠CAUTION: If an inverter is to be connected to the system, connect the inverter directly to the battery.

Step 4: Connect accessories

- ① Connect the remote temperature sensor cable to the interface and place the other end close to the battery
- ② Plug the external Bluetooth or WiFi module into the RJ45 interface and the indicator light on the module will be on.

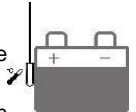

Step 5: Grounding

Tracer Dream 200V series are common-negative controllers. Negative terminals of the PV array, the battery can be grounded simultaneously. However, according to the practical application, the PV array and battery's negative terminals can also be grounded.

For common-negative systems, such as the RV system, it is recommended to use a common-negative controller. If a common-positive controller is used and the positive electrode is grounded in the common-negative system, the controller may be damaged.

Step 6: Power on the controller

- ① After connecting all power wires solidly and reliably, check again whether wiring is correct and if the positive and negative poles are reversely connected. After confirming that no faults exist, firstly switch on breaker of the battery, then see whether the LED indicators light be on and the LCD screen displays information. If the LCD screen fails to display information, switch off the breaker immediately and recheck if all connections are correctly done.
- ② If the battery functions normally, then connect the solar panel or switch on the breaker of solar panel. If sunlight is intense enough, the controller's charging indicator will light up or flash and begin to charge the battery.

Note: 1) If no remote temperature sensor is connected to the controller, the battery temperature value will stay at 25 °C.



2) If an inverter is deployed in the system, directly connect the inverter to the battery.

3. Operation













3.1 Button









Mode	Note
Dry contact ON/OFF	Short press the “OK” button can turn on/off the dry contact
Clear Fault	Press the “Return” button(⌫) on the charging power(AH) interface
Browsing Mode	Press the “UP”(▲)and”Down”(▼) button.
Working Record	Long press “MENU”and”UP”(▲)for more than 5 seconds
Setting Mode	Press the “UP”(▲)and”Down”(▼) button to browse, then press “OK” to enter the setting mode Press the”UP”(▲)and”Down”(▼) button to adjust the parameters.Long press the “OK” button. to save the setting parameters.if no operation for 10s or press”Return” button(⌫) to exit the setting mode.

3.2 Interface

(1) Status Description

Item	Icon	Status
PV array		In daytime and PV connected correctly
		At night or no PV connect or reverse connect
		No Charging
		Charging In MPPT
		In Float Charging Mode
		In Boost Charging Mode
	PV	PV Voltage, Current and Power
Battery		Battery Capacity Indicating
	12V 24V 48V	Current System Voltage
	BAT	Battery Voltage and Current
	BAT TYPE	Battery Type
Dry Contact		Dry Contact ON
		Dry Contact OFF
		Dry Contact Light and Time Control Mode
		Dry Contact Light Control Mode
	LOAD TYPE	Dry Contact Working Mode
	LOAD	Data about Dry Contact

(2) Fault Indication

Status	Icon	Description
Battery over discharged	 	Battery level shows empty, battery frame blink, fault icon blink
Battery over voltage	 	Battery level shows full, battery frame blink, fault icon blink
Controller over temperature	 	Temp.icon shows Temp.inside controller is higher than 75°C, temperature icon blink, fault icon blink
PV over voltage	 	It shows PV voltage is higher than rated PV open voltage.PV icon blink,fault icon blink
LED flash	Normal Charging	
LED on and off gradually	PV voltage is too low to start charging	
LED Off	Stop Charging	

(3) Browse interface

①If there is no operation within 20s or after powered on within 10s in any interface.The main interface will cycle to display the battery voltage,PV voltage,charging current,battery type and battery temperature every 3s.Long press the“UP”(▲)and“Down”(▼) can speed up the cycle display time.

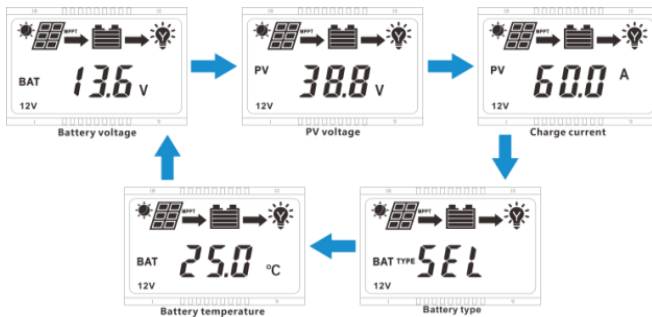

②At main interface(cycle display),long press “MENU”and“UP”(▲) for more than 5S at same time to enter working record status,it can show times of low voltage,working days,times of over current and times of full charging.Press “Return” button(⌫) to return to the main menu.

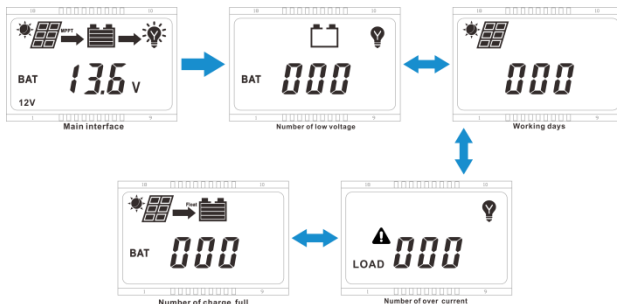

③At main interface(cycle display),Press the “MENU” button and enter menu interface.Press “ ⌫ ” to exit from

any interface.

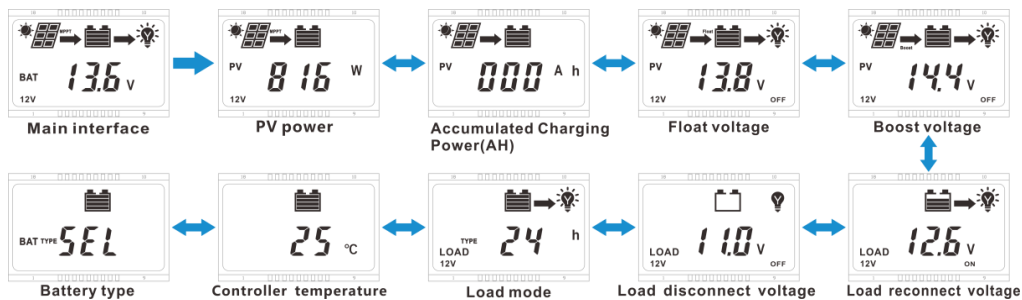

3.3 Setting

(1) Clear the charging power(AH)

Operation:

Press the “Return” button(⌫) on the charging power(AH) interface and the value will be cleared.

(2) Float Voltage Setting

Operation:

Step 1: At main interface(cycle display),Press “UP”(▲)and” Down” (▼) to enter float voltage interface.

Step 2: Press the “OK” button and the value flashes,Now it enters the setting state.

Step 3: Press the “UP”(▲)and” Down” (▼) button to change the value.

Step 4: After setting,Long press the “OK” button($\geq 5S$) to save the new setting.Press “Return” button(⌫) to exit without saving.If there is no operation within 20s,the controller will enter the main interface and cycle to display automatically.

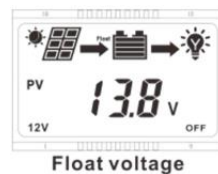

(3) Setting of boost voltage, low voltage reconnect voltage and low voltage disconnect voltage

Operation:At main interface(cycle display),Press the“UP”(▲)and” Down” (▼) button to enter the relevant interface below:

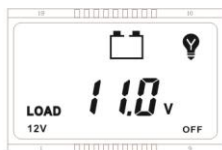

Low Voltage Disconnection Voltage

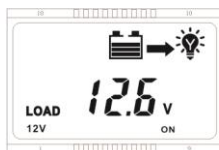

Low Voltage Reconnection Voltage

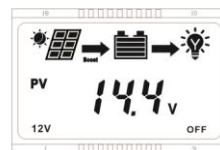

Boost voltage

The operation method of setting is the same as float voltage setting,Please refer to the above “(2)”

■ The following rules must be observed when modifying the parameter values in User

I .Charging Limit Voltage >Boost Charging Voltage >Float Charging Voltage > Boost Reconnect Charging Voltage.

II .Low Voltage Reconnect Voltage > Low Voltage Disconnect Voltage(BMS+0.2V)

III. Boost Reconnect Charging voltage > Low Voltage Reconnect Voltage > Low Voltage Disconnect Voltage(BMS+0.2V)

■ Battery Voltage Control Parameters

Below parameters are in 12V system at 25 °C, please double the values in 24V system and quadruple the values in 48V system

Battery Type	SEL	GEL	FLD	LF4(LiFePO44S/12V)	Li3	Li7 (Li(NiCoMn)O2 7S/24V)
--------------	-----	-----	-----	--------------------	-----	---------------------------

	24V*2;48V*4	24V*2;48V*4	24V*2;48V*4	LF8 (LiFePO4 8S/24V*2) LFG (LiFePO4 16S/48V*4)	(Li(NiCoMn)O2 3S/12V)	Lld (Li(NiCoMn)O2 14S/48V*2)
Over Voltage Disconnect	16.0V	16.0 V	16.0 V	16.0V	17.0 V	32.0V
Charging Limited Voltage	15.0 V	15.0 V	15.0 V	14.8V	17.0 V	30.0V
Over Voltage Reconnect	15.0 V	15.0 V	15.0 V	14.8V	17.0 V	30.0V
Boost charge	14.4 V	14.2 V	14.6 V	14.6V	12.6V	29.4V
Float charge	13.8 V	13.8 V	13.8 V	14.4V	12.4V	29.0V
Boost Restart Voltage	12.6V	12.6V	12.6V	13.0V	11.5V	26.0V
Low voltage reconnect	12.6V	12.6V	12.6V	12.6V	11.0V	25.2V
Low voltage disconnect	11.0V	11.0V	11.0V	10.5V	9.0V	21.0V

(3) Battery type

① Support battery types

Lead-acid battery	Sealed(default)
	Gel
	Flooded
	User
Lithium battery	LiFePO4(LF4/12V;LF8/24V;LF16/48V)
	Li(NiCoMn)O2 (LI3/12V;LI7/24V;LI d/48V)

② Setting the battery type via LCD

Step 1: At main interface(cycle display),Press the “ UP”(▲)and” Down” (▼) button to enter battery type mode interface.

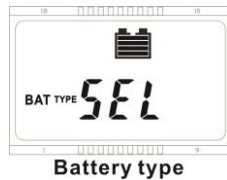

Step 2: Press the “OK” button once and the “SEL” flashes,then it enters the setting state.

Step 3: Press the“UP”(▲)and” Down” (▼) button to select the battery type below:

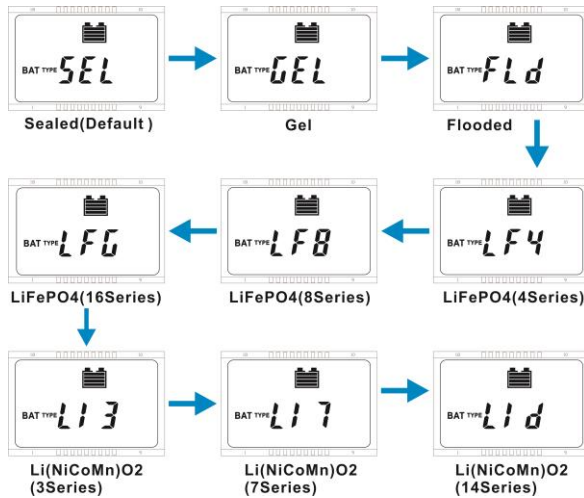

Step 4: Long press the “OK” button(≥5S) to save the new setting.Press “Return” button(⏪) to exit without saving.If there is no operation within 20s,the controller will enter the main interface and cycle to display automatically.

(5) Bluetooth Module

Step 1:Turn on the Bluetooth switch of the mobile phone,then open the iConnect App-- select wireless communication--device--communication selection-Bluetooth.

Step 2:Click the “Search Device” button--select the device whose name begins with BT04--enter the password 0000/1234-- connection succeeded.

①App Download

-Android/Harmony System

Method 1: Scan the following QR code with your mobile browser and enter the App download page. Click the latest version of the download file directly, and then install it directly (if prompted during the installation process, please select "Trust" and "Allow" to continue the installation. Harmony system should not turn on pure mode)

Method 2: The mobile phone web page can be downloaded and installed directly by logging in to <https://www.ldsolarpv.com/jszc#> or <https://www.ldsolar.com/download>.

Method 3: Google Play application market download

Search for "LD iConnect" in Google Play Application market and find ldsolar's app. The icon is as follows. Just download and install it directly.



-IOS for Apple

Search for "LD iConnect" in the Apple store, and find ldsolar's app, with the icon above, just download and install it directly.

Note:

•After downloading the App, please check the application update in My iConnect --click Automatic Update to the latest version. In this way, you can enjoy the latest application functions.

②How to use iConnect App



Please refer to the instruction manual of iConnect App for details. Scan the QR code or download from the iConnect App.

4. Protections, Troubleshooting and Maintenance

4.1 Protection

PV current/power limiting protection	When the charging current or power of the PV array exceeds the controller's rated current or power, it will be charged at the rated current or power. NOTE: When the PV modules are in series, ensure that the open-circuit voltage of the PV array does not exceed the "maximum PV open-circuit voltage" rating. Otherwise the controller may be damaged.
PV Short Circuit	When not in PV charging state, the controller will not be damaged in case of a short-circuiting in the PV array.
PV Reverse Polarity	When the polarity of the PV array is reversed, the controller may not be damaged and can continue to operate normally after the polarity is corrected.
Night Reverse Charging	Prevents the battery from discharging through the PV module at night.
Battery Reverse Polarity	Fully protected against battery reverse polarity; no damage will occur for the battery. Correct the wrong wiring to resume normal operation. NOTE: Limited to the characteristic of lithium battery, when the PV connection is correct and battery connection reversed, the controller will be damaged.
Night reverse charging protection	Prevent the battery from discharging to the PV module at night.
Battery Over Voltage	When the battery voltage reaches the over voltage disconnect voltage, it will automatically stop battery charging to prevent battery damage caused by over-charging.
Battery Over Discharge	When the battery voltage reaches the low voltage disconnect voltage, it will automatically stop battery discharging to prevent battery damage caused by over-discharging. (Any controller connected loads will be disconnected. Loads directly connected to the battery will not be affected and may continue to discharge the battery.)







Controller Overheating	The controller is able to detect the temperature inside the battery. The controller stops working when its temperature exceeds 85 °C and restart to work when its temperature is below 65 °C.
TVS High Voltage Transients	The internal circuitry of the controller is designed with Transient Voltage Suppressors (TVS) which can only protect against high-voltage surge pulses with less energy. If the controller is to be used in an area with frequent lightning strikes, it is recommended to install an external surge arrester.

★When the internal temperature is 75°C, the reducing power charging mode which reduce the charging power of 5% every increase 1 °C is turned on. If the internal temperature is greater than 85°C, the controller will stop charging. When the temperature declines to be below 65 °C, the controller will resume.

4.2 Troubleshooting

Possible reasons	Faults	Troubleshooting
------------------	--------	-----------------

PV array disconnection	LCD display during daytime 	Confirm that PV wire connections are correct and tight.
Battery voltage is lower than 8V	Wire connection is correct, the controller is not working.	Please check the voltage of battery. At least 8V voltage to activate the controller.
Battery over voltage	  Battery level shows full, battery frame blink, fault icon blink	Check if battery voltage is higher than OVD(over voltage disconnect voltage), and disconnect the PV.
Battery over discharged	  Battery level shows empty ,battery frame n blink	When the battery voltage is restored to or above LVR(low voltage reconnect voltage), the load will recover

4.3 Maintenance

The following inspections and maintenance tasks are recommended at least two times per year for best performance.

- Make sure controller firmly installed in a clean and dry ambient.
- Make sure no block on air-flow around the controller. Clear up any dirt and fragments on radiator.
- Check all the naked wires to make sure insulation is not damaged for solarization, frictional wear, dryness, insects or rats etc. Repair or replace some wires if necessary.
- Tighten all the terminals. Inspect for loose, broken, or burnt wire connections.
- Check and confirm that LED is consistent with required. Pay attention to any troubleshooting or error indication .Take corrective action if necessary.
- Confirm that all the system components are ground connected tightly and correctly.
- Confirm that all the terminals have no corrosion, insulation damaged, high temperature or burnt/discholorred sign, tighten terminal screws to the suggested torque.
- Check for dirt, nesting insects and corrosion. If so, clear up in time.
- Check and confirm that lightning arrester is in good condition. Replace a new one in time to avoid damaging of the controller and even other equipments.

WARNING: Risk of electric shock!



Make sure that all the power is turned off before above operations, and then follow the corresponding inspections and operations.

5. Technical Specifications

5.1 Electrical Parameters

Item	TD4620Pro	TD4820Pro	TD41020Pro
System nominal voltage	12/24/48VDC Auto ①		
Rated charge current	60A	80A	100A
Battery voltage range	8 ~ 68V		
Max. PV open circuit voltage	② 180V ③ 200V		
MPP voltage range	(Battery voltage +2V) ~ 144V		
Rated charge power	800W/12V 1600W/24V 3200W/48V	1000W/12V 2100W/24V 4200W/48V	1300W/12V 2600W/24V 5200W/48V
Self-consumption	≤70mA(12V)/40mA(24V)/24mA(48V)		
LVD	11.0V ADJ 9V....12V; ×2/24V; ×4/48V		
LVR	12.6V ADJ 11V....13.5V; ×2/24V; ×4/48V		
Float voltage	13.8V ADJ 13V....15V; ×2/24V;; ×4/48V		
Boost voltage	14.4V ; ×2/24; ×4/48V Battery Voltage less than 12.6V Start Boost changing for 2hours(Li-battery not)		
Discharge circuit voltage drop	≤0.12V		
MPPT tracking efficiency	≥99.5%		

Max. Conversion efficiency	98%
Grounding	Common negative
Battery Type	Sealed(Default)/Gel/Flooded/LiFePO4/ Li(NiCoMn)O2/ User
Temperature compensate Coefficient ④	-4mv/°C/2V
Dry contact	Rated value: 3A/30VDC; Max. value: 0.5A/60VDC
Communication method	RS485(5VDC/200mA)
LCD backlight time	Default: 15S

- ①When a lithium battery is used, the system voltage can't be identified automatically.
- ②At minimum operating environment temperature
- ③At 25°C environment temperature
- ④When a lithium battery is used, the temperature compensate coefficient will be 0.

5.2 Environmental Parameters

Working environment temperature◆	-20°C ~ +50°C(100% input and output)
Storage temperature range	-20°C ~ +70°C
Relative humidity	≤95%, N.C.
Enclosure	IP30

◆The controller can work under full load in the working environment temperature, When the internal temperature is more than 80°C, the reducing power charging mode is turned on.

5.3 Mechanical Parameters

Item	TD4620Pro	TD4820Pro	TD41020Pro
Dimension(L*W*H)	277×244×111mm	375*244*135.5mm	468*244*135.5mm
Mounting Dimension(A*B)	226×176mm	226×216mm	226*216mm
Mounting hole size	Φ7mm		
Weight	4.5Kgs	6.8Kgs	8.2Kgs

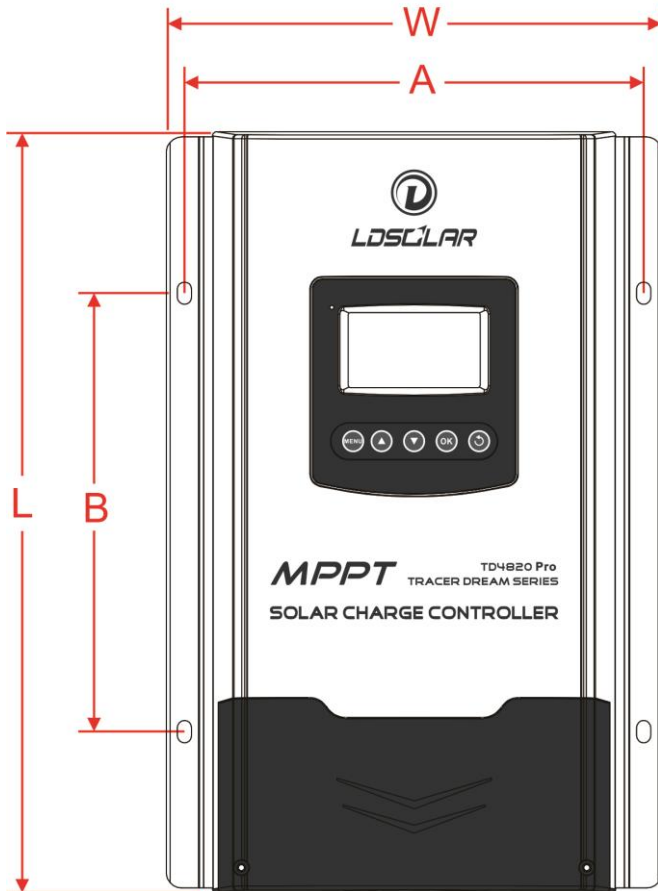
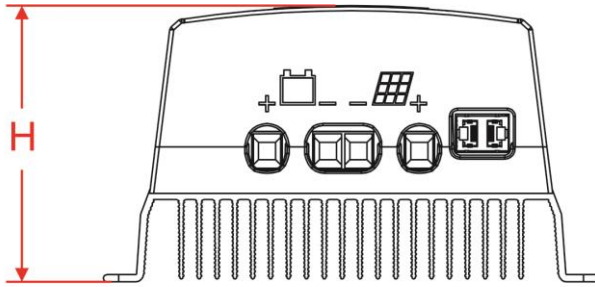

FCC Warning:

This equipment has been tested and found to comply with the limits for a Class B digital device, pursuant to part 15 of the FCC Rules. These limits are designed to provide reasonable protection against harmful interference in a residential installation. This equipment generates, uses and can radiate radio frequency energy and, if not installed and used in accordance with the instructions, may cause harmful interference to radio communications. However, there is no guarantee that interference will not occur in a particular installation. If this equipment does cause harmful interference to radio or television reception, which can be determined by turning the equipment off and on, the user is encouraged to try to correct the interference by one or more of the following measures:

- Reorient or relocate the receiving antenna.
- Increase the separation between the equipment and receiver.
- Connect the equipment into an outlet on a circuit different from that to which the receiver is connected.
- Consult the dealer or an experienced radio/TV technician for help.

Caution: Any changes or modifications to this device not explicitly approved by manufacturer could void your authority to operate this equipment.

This device complies with part 15 of the FCC Rules. Operation is subject to the following two conditions:

(1) This device may not cause harmful interference, and (2) this device must accept any interference received, including interference that may cause undesired operation.

This equipment complies with FCC radiation exposure limits set forth for an uncontrolled environment. This equipment should be installed and operated with minimum distance 20cm between the radiator and your body.

WE
SEEK
EXCELLENCE



Your battery guard

solar charge controller