

> The mower will automatically exit the charging station and move 60 in. ahead, without the need for manual intervention.

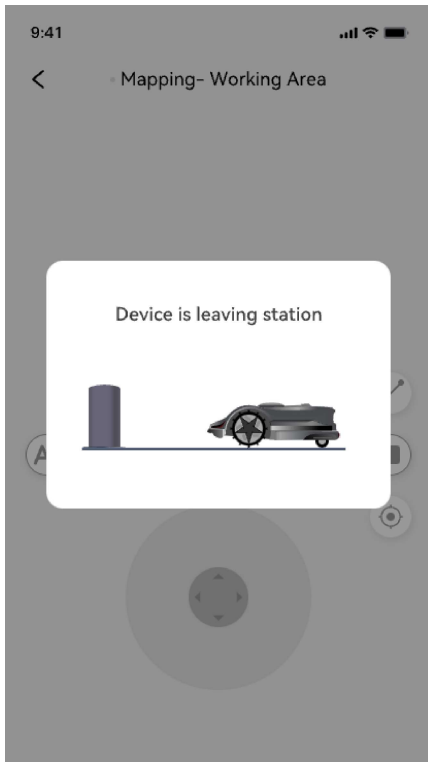

> Remotely control your machine to go around the borders of the lawn. Make sure that the dotted path displayed on the App forms a closed shape.

> Click the "⏏" button to finish remote control. Click "Confirm" to generate the map.

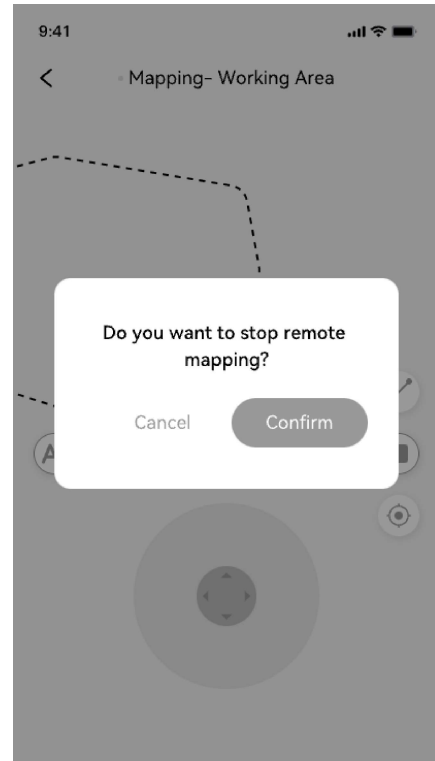

> Find a proper starting point along the edge of your lawn and place the mower 5.9 in away from the edge.

> Click the "▶" button to start remote mapping. Walk along the edge while creating the map. Always keep 5.9 in distance from the edge and 19.7 in distance from the walls.

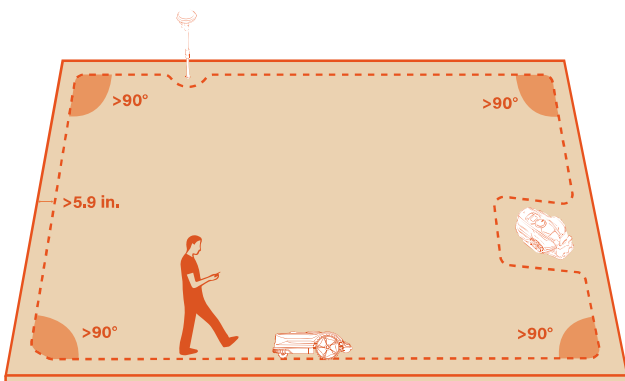

Step 2: Create No-Go Zones and Virtual Walls

The lawnmower will automatically avoid obstacles, such as large rocks or tree trunks. In case of items that need extra protection or areas that you don't want the machine to enter, you can set up no-go zones or virtual walls with the app.

> Click the "Map Settings" icon to enter the map building panel and choose the "No-Go Area/Virtual Wall" function to create a no-go zone for the map. Click the "No-Go Area" icon to place a square no-go zone on the map to forbid the machine from entering this area.

> You can also create virtual walls to customize the forbidden area. Click the "Virtual Wall" icon to place the virtual walls on the map as you like.

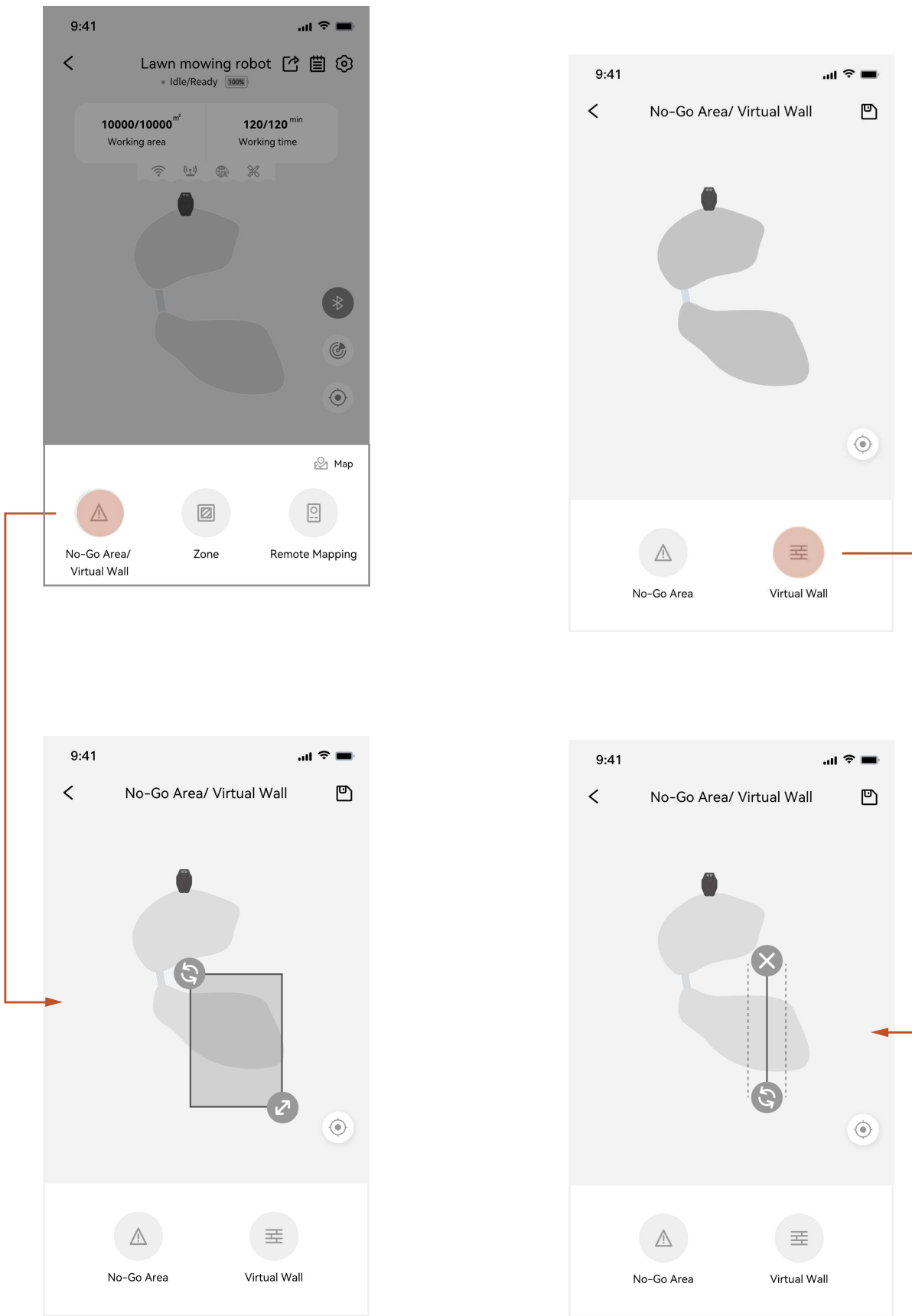

Step 3: Create the Corridor

> Click "Map Settings" icon to enter the map building panel. Choose the "Remote Mapping" function to create a corridor via remote control.

You can control the machine to go through the path between 2 work zones to create the transport path or you can control the machine to go through the corridor after creating the first work zone and later creating the second one.

You need to specify the **starting point** and the **ending point** in the map for the corridor no matter which method you choose to create it.

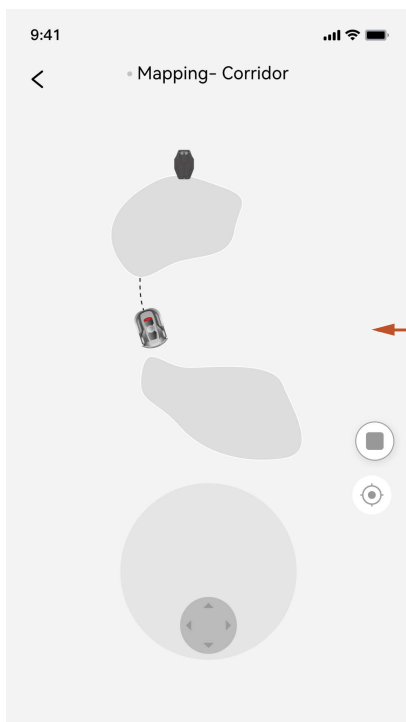
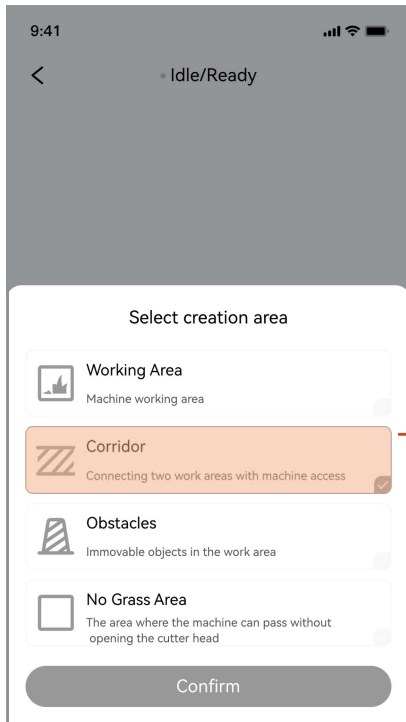

Step 4: Edit/Delete the map

> Click the "Map Settings" icon to enter the map building panel and choose the "my map". You can Edit or delete the map you have created.

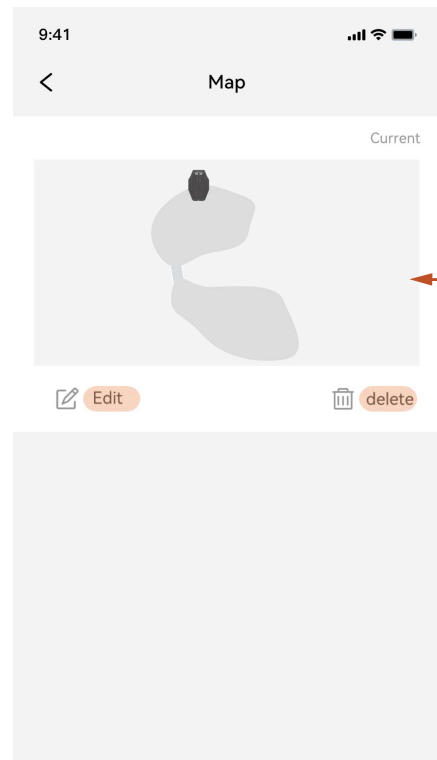
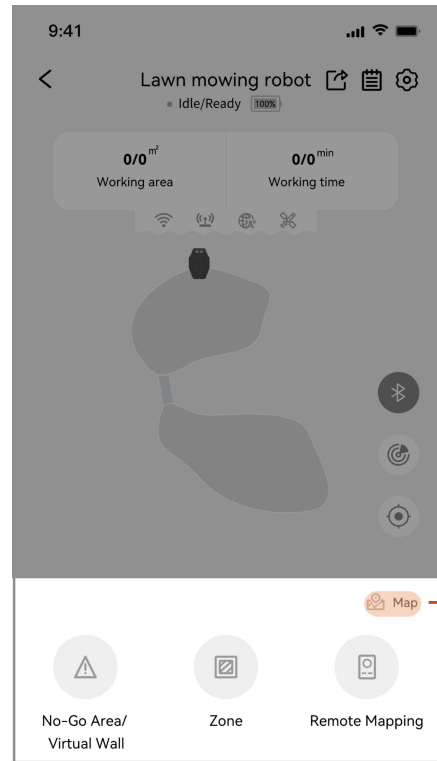

3.8 App Settings

You can browse and adjust the Platform X app-related settings on this page.

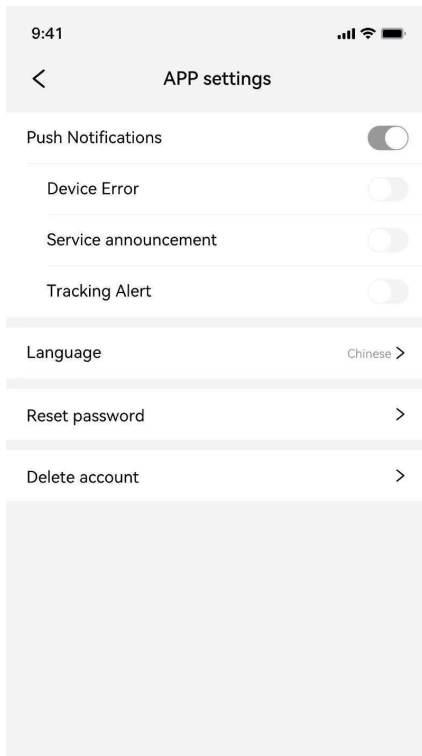

Language

You can set the language as you need it. The app currently supports 12 languages.

Help and support

You can view the latest User Manual, FAQ and contact of after-sales service here.

About

You can view the Terms of Use and Privacy Policy here.

Log out

You can log out of your account here, and your data will not be deleted after logging out.

3.9 Notifications

System notifications

Latest news and updates from the Sunseeker team.

Device notifications

The mower will send you device notifications in the following situations: work status update (such as mowing completed), blade replacement, unexpected behaviors, abnormal position, etc.

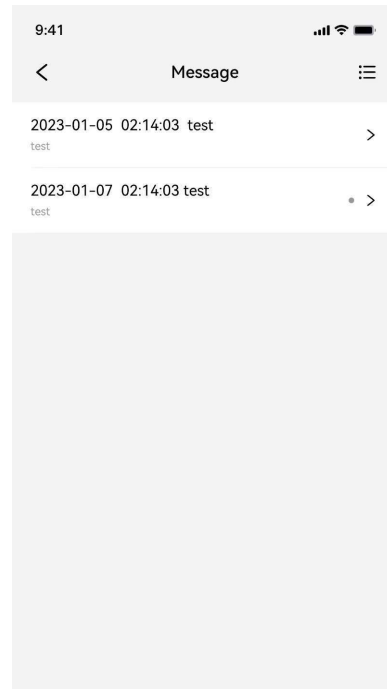

Pop-up messages

Pop-up messages appear in the centre of the screen. For example, an error code message appears if an error has occurred.

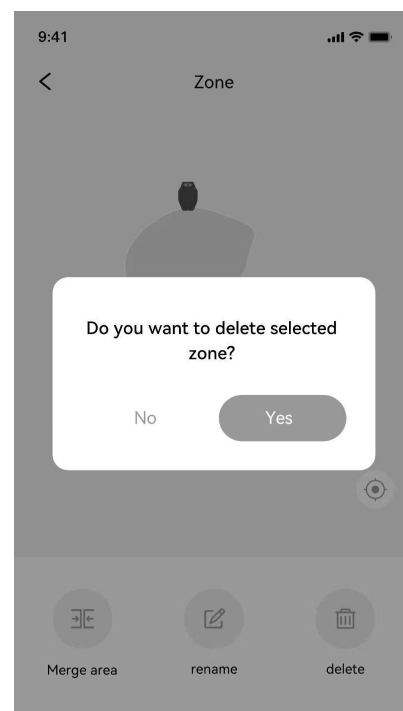

4. Daily Operation

4.1 Display and Control on the Mower

Display

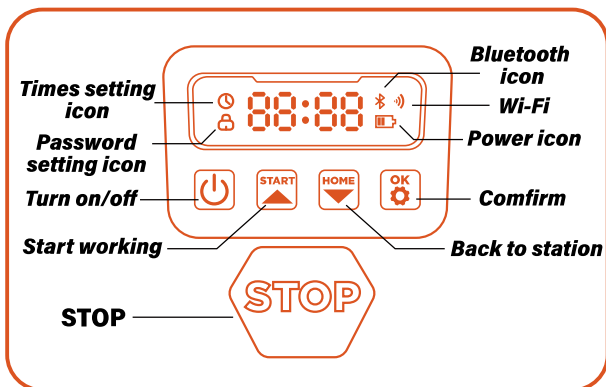

Power icon: The battery power icon shows the remain power of the machine. This icon displaying 1 bar indicates that the power is 30% or under, displaying 2 bars indicates that the remain power is between 31-66%, and displaying 3 bars indicates power of 67% and higher.

Wi-Fi icon: The Wi-Fi icon indicates whether the machine connects successfully to the Wi-Fi or not.

Bluetooth icon: The Bluetooth icon indicates whether the machine is connected to Bluetooth successfully or not.

Time setting icon: The time setting icon indicates that the machine has entered the time setting mode.

Password setting icon: The lock icon lighting up indicates that you need to enter the password or change the machine's password.

Dashboard display: The dashboard display shows the different states and modes the machine is in:

- . **idel:** The machine is in standby mode and there are no tasks in execution at this time.
- . **Running light:** The machine is in working mode. At this time, the disk is rotating at high speed. Please keep away from it.
- . **----**: When the rain delay is turned on, the machine recognizes that it is raining at this moment, ends the current work and returns to the charging station.
- . **stop:** The emergency stop button was pressed on the machine.

Basic Control

Turn on: Press and hold power button for 2s.

Turn off: Press and hold power button for 3s. The mower cannot be turned off when it's in the charging station. When the mower is turned off, you will see the word "bye" displayed on the dashboard and then the screen will turn off.

Start working/Turn on: Press START button and then OK. Back to station/Turn off :Press HOME button and then OK.

Stop mower operation: Press STOP.

Restart the mower: Press and hold the power button for 10s to turn off the machine, then turn it on again or directly push the machine into the charging station and connect it to the charging electrodes on the station.

NOTE: If the mower is in lock status, you must enter the PIN code before manually operating the mower. The default code is 0000, and can be changed via the Robotic Mower app.

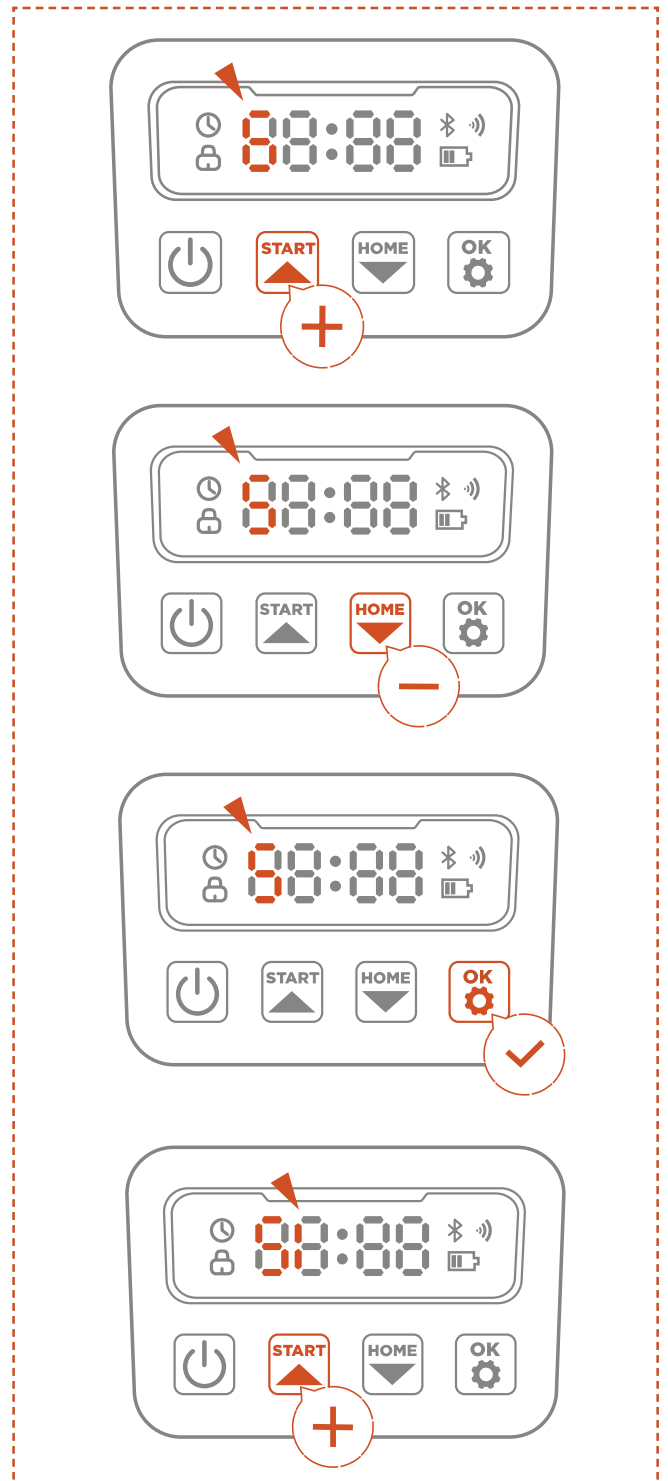

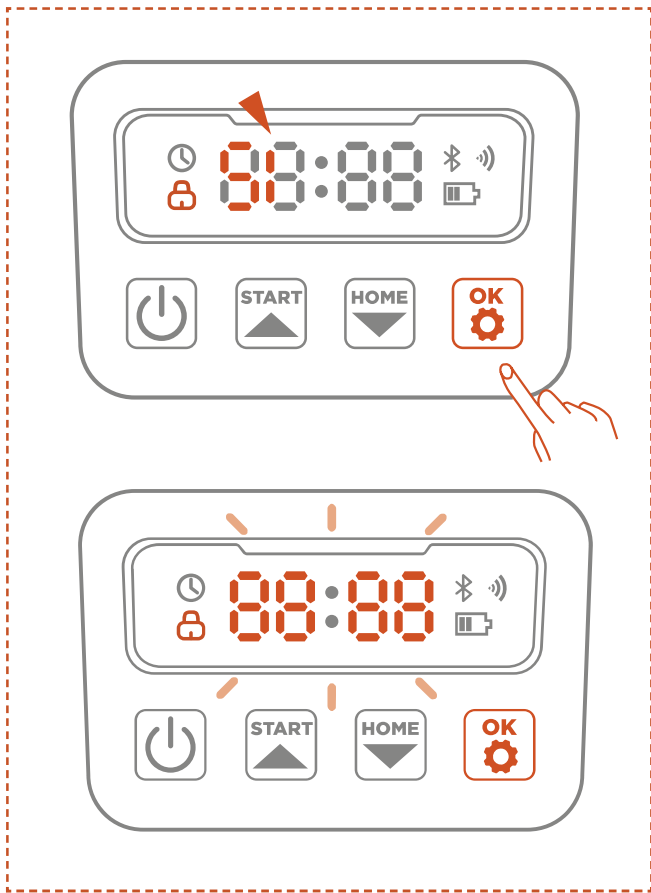

How to enter the Pin code: When entering the password, you can use the START button as the plus key (+) and the HOME button as the minus key (-). Then, press the OK button to confirm each number.

START (+)
HOME (-)
OK (confirm)

When input the default code 0000, press the OK button four times to correctly input the password.

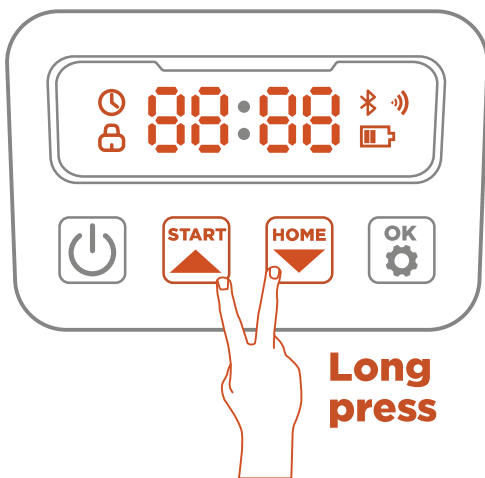

How to change the password:

1. Long press START and HOME buttons for 3 seconds. The display will show "PIN1" for 1 second,

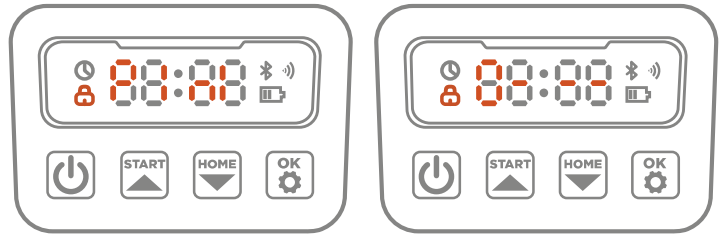

followed by "0— — —". Enter the current password. If entered incorrectly, "ERR" will be displayed, prompting you to re-enter.

2.If the correct password is entered, "PIN2" will be displayed after 1 second, followed by "0— — —" again. Enter the new password you wish to set, press OK to confirm and the password has been changed.

4.2 IoT

The Platform X is an Internet of Things (IoT) device. Connect the mower to the Internet via cellular network or your Wi-Fi network, enabling the following functionalities:

1. Firmware Updates Over-The-Air (OTA), keep your mower updated to the latest features.
2. Enables remote control through the network: start mowing, stop mowing, return to charging station, set mowing schedule, set cutting height and other functions.
3. Remotely monitor the mowing progress and mower location.
4. Report error code and mower status through the network.

Wi-Fi

Platform X uses Wi-Fi to connect to a network. See Wi-Fi Setting for more details.

NOTES:

- Platform X only supports 2.4GHz Wi-Fi network.

- If you are using an iOS device, the mower can only connect to the Wi-Fi that your mobile device is connected to. Please follow the instructions in the app. Connect your mobile device to the Wi-Fi first, then connect the mower to the same Wi-Fi. There are no such requirements for Android devices.

Firmware updates

We will continue to update the mower's firmware. If there is a new version of the firmware, you will receive a pop-up notification in the app. It is recommended that you update as soon as the latest firmware is available.

When updating the firmware, the conditions below need to be met:

- The machine is on the charging station.
- The network is connected.
- The battery power is more than 30%.
- There is no mowing plan in an hour.

In the process of updating, the ambient light on the mower will flash blue. You can see the update progress on your app. After the update is completed, the ambient light of the mower will turn green.



WARNING

DO NOT move the mower during the update process.

4.3 Obstacle Avoidance

Binocular Camera

Binocular camera is part of the standard equipment of Platform X. They are designed for visual boundary detection, prior obstacle avoidance and visual recognition of QR codes during the charging process, making the mower more intelligent.

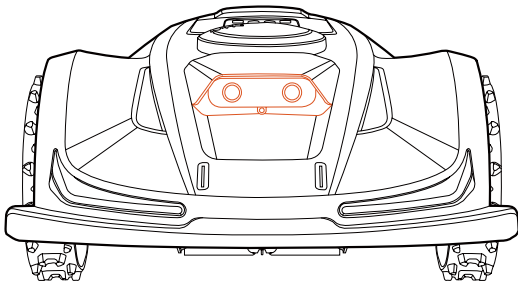

NOTE:

- Working in pitch-black environments can affect the machine's ability to recognize obstacles accurately and quickly to avoid them. It is therefore recommended that you do not operate the machine at night.

- If there are too many obstacles in your lawn, consider setting up no-go zones around them or removing some of the obstacles to improve the machine's efficiency.

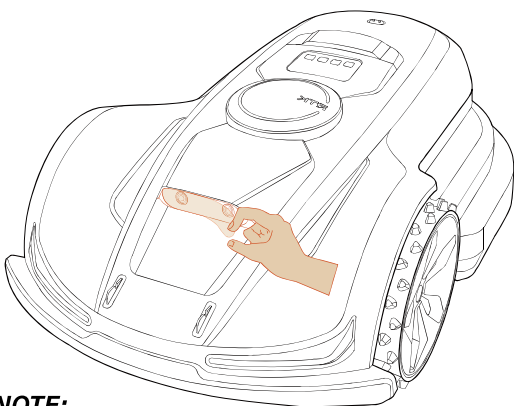

NOTE:

Please make sure to remove the protective film outside the front camera before use. If the lens becomes dirty during subsequent use, you can clean it with a soft cloth.

5. Maintenance

Experience superior mowing results and extend the lifespan of your mower with Maintenance. Regular inspection and upkeep by an adult every week is essential to ensure optimal performance. Safeguard your well-being by adhering to safety guidelines: refrain from performing maintenance while wearing open sandals or being barefoot. Always prioritize safety by donning long trousers and work shoes during mower servicing. Replace any damaged or worn parts promptly to guarantee seamless operation.

ONLY authorized service technicians are permitted to open and reseal the chassis compartment located behind the bumper. The Limited Warranty may be voided if you perform your own servicing.

NOTICE: INSURANCE

You might not be covered for accidents involving this product by your insurance policies. Please get in touch with your insurance provider or agent to find out if coverage is offered.

5.1 Cleaning

Utilize a gentle brush or cloth to meticulously clean the exterior, avoiding any corrosive solvents such as alcohol, gasoline, or acetone. These substances have the potential to cause harm to both the aesthetics and internal components of your mower.

For seamless docking, it is crucial to regularly examine and cleanse the charging station from any debris or mud accumulation. Ensure that all connecting parts of the charging station, extension cable, and power supply remain unobstructed for optimal performance.

A. Chassis and blade disc

To clean the chassis and blade disc, it is recommended to use a brush or a water hose. It is important to avoid using a high-pressure washer as it can cause damage. Additionally, ensure that the blade disc rotates smoothly, and the blades have the ability to pivot without any restrictions.

CAUTION: High pressure water can leak into the sealings and damage electronic and mechanical parts.

B. Wheels

Grass on the wheels can impair the performance of the mower when climbing slopes. Remove mud or other objects in between to ensure a good grip. Use a brush to clean the drive wheels (rear wheels) to ensure that the tread has a good grip.

C. Rain sensor

Check the rain sensor once a month and make sure that it is not covered by mud, grass or other objects. You can either wash it off or clean it with a soft brush. Dry the sensor area after cleaning so that it is not triggered as it would be by rain.

WARNING

- Make sure the mower is powered off before cleaning.
- The mower needs to be turned off while it is upside down.

5.2 Replace Blades

For improved mowing performance and safety, it is advised to change the mower's screws and blades every 1-2 months if it is used frequently. For a safe cutting system, replace all blades along with their screws at the same time. Refer to section 'Specification - accessories' for parts can be used.

WARNING

- When inspecting or servicing the blade, wear thick gloves.
- We strongly advise using the correct screws and original blades that have been sold by us.(NO. 80201457)
- DO NOT reuse the screws. Serious injury may result from doing this.

How to replace the blades

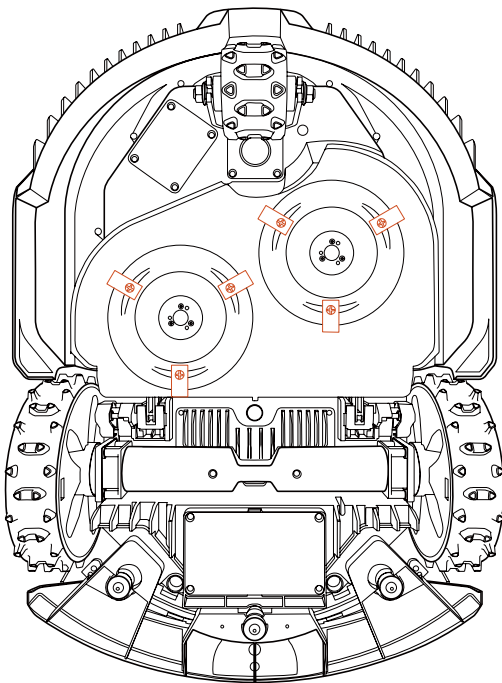

1. Turn off the mower.
2. Set the mower upside-down on a spotless, soft surface to prevent scratches.

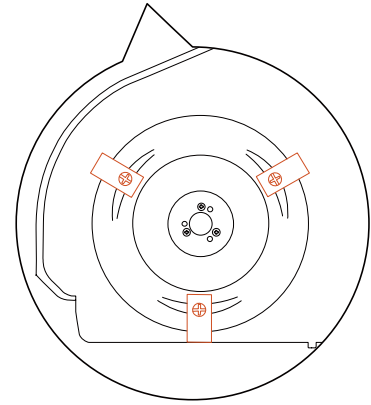

3. Use a cross-tip screwdriver to loosen the screws.

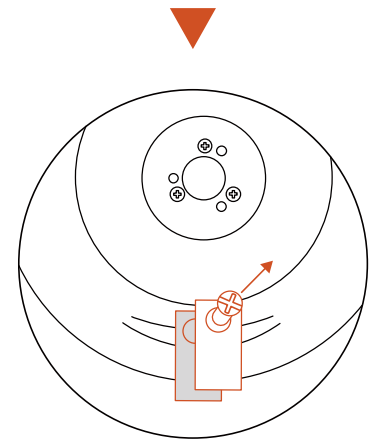
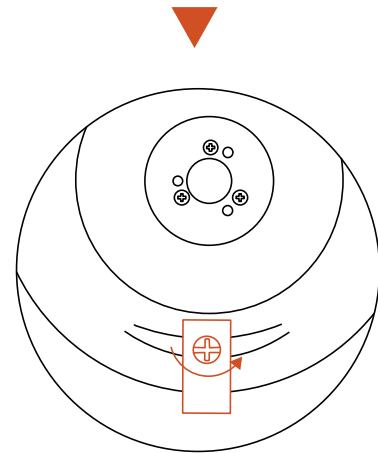

4. Remove the screws and blades.
5. Fasten the new blades and screws (Torque: $1.0+0.2N.m$). Make sure the blades can pivot freely.

NOTE:

1. Replace the screws with a standard torque of $1.0+0.2N.m$. Incorrect torque may lead to avoidable issues.
2. Ensure the mower is turned off and inspect the blades for proper application. Any abnormal noise or shaking should be investigated.

5.3 Transportation

Ensure the safety of the mower during long-distance transportation by utilizing the original packaging. Prior to lifting, moving, or transporting the product, make sure to switch it off. Handle with care and avoid violent force, such as throwing and heavy pressure. Never pick up or carry the mower while the motor is running.

How to move or lift properly

Carry the mower by the handle, with the blade disc facing away from your body.

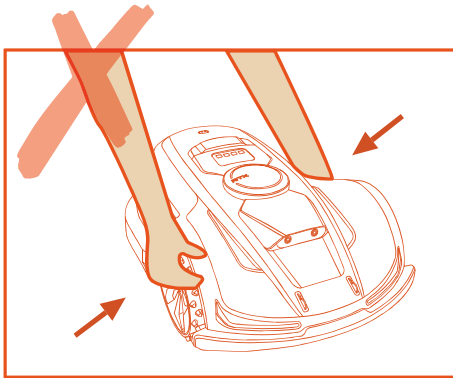
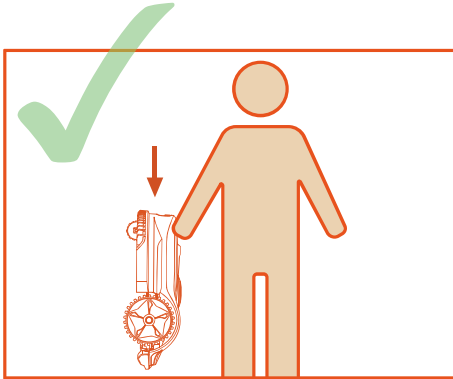

5.4 Battery

- Before storing, fully charge the battery to prevent over-discharge and harm to the electrical parts.
- The Limited Warranty will not protect against over-discharge battery damage.
- DO NOT charge the battery pack in air temperatures below 5°C (41°F), or above 40°C (104°F).
- Longer life and better performance can be obtained if the battery pack is charged when the air temperature is between 18°C and 25°C.
- Battery pack gives its best performance when it is operated at normal room temperature (20 °C ± 5 °C).

NOTE:

The battery life depends on how often the product is used and the total working hours. When the operation time is significantly shorter than usual per full charge or the lawn is not well-cut, consider replacing the battery.

How to replace the battery

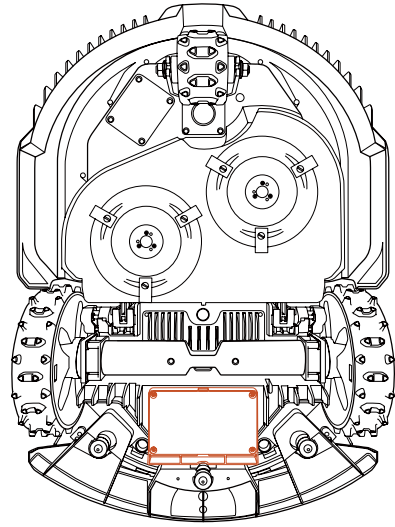

1. Turn off the mower.
2. Set the lawnmower upside-down on a spotless, soft surface.

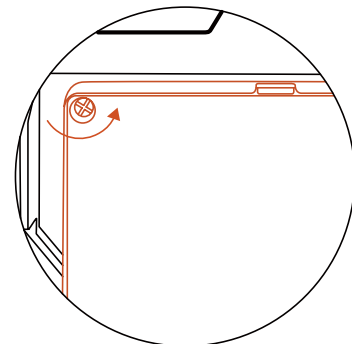
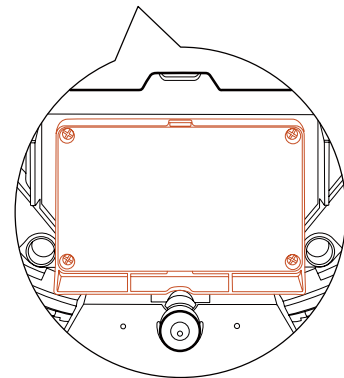

3. Loosen the 4 screws holding the battery compartment in place with a cross-tip screwdriver.

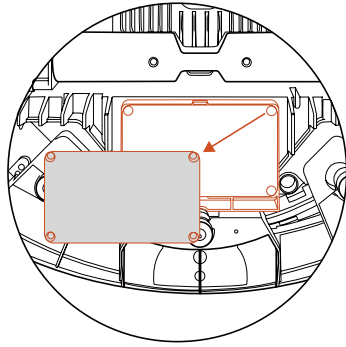

4. Disconnect the plug.

5. Take out the battery pack and replace it with the new one.



WARNING

- Use only the original battery pack or that of the same model as specified by SUNSEEKER. Each mower contains one battery pack.

- Depending on the specific mower model, the rated capacity of the battery is 5000 mAh, or 10000 mAh.

- Do not use non-rechargeable batteries. For the purposes of recharging the battery, only use the detachable supply unit provided with this appliance.

- Avoid breaking or disassembling the battery casing. Avoid contact with metal objects to avoid short circuits. Steers clear of heat sources, fire, and direct sunlight.

- Please get in touch with your point-of-sale, your local or regional waste management office, or your household waste disposal service for more information about battery and electrical waste.

- It is not intended for the battery compartment to be opened frequently. If a new battery is required, only then should you open the battery compartment.

- The battery pack contains electrolytes. If the electrolyte leakage comes into contact with your skin, wash off with soap and water immediately. Get medical help in case of eye contact and immediately flush the eyes with plenty of water for at least 15 minutes without rubbing.

5.5 Power Supply

Disconnect the power supply:

- Before clearing a blockage;
- Before checking, cleaning or working on the machine;
- After striking a foreign object to inspect the machine for damage.
- Regularly examine the cord, plug, enclosure and other parts. If any damage or signs of aging are found, stop using immediately.



WARNING

- NEVER use a damaged power supply for operation. To prevent a hazard, the supply cord must be replaced by the manufacturer, its service agent, or other appropriately qualified individuals if it is damaged. In the event that the extension cable is faulty, kindly swap it out for the 10-meter cable that SUNSEEKER has approved.

- NEVER touch an extension cable or damaged cord before it has been unplugged from the power source or connect it to the power supply. A damaged cord may cause contact with electrical components.

- The power supply should not be used with any other device or battery as this increases the risk of electrical shock, fire, or personal injury. If you use anything other than original batteries, product safety cannot be guaranteed.

- DO NOT charge when the battery is leaking.
- Keep the extension cable away from moving hazardous parts to avoid damage to the cords which can lead to contact with live parts.

Recommendation

Connect the mower and/or its peripherals only to a supply circuit protected by a residual current device (RCD) with a tripping current of not more than 30 mA.

5.6 Storage

- Please make sure the mower is fully charged and turned off before storing it to prevent over-discharge, which could result in permanent damage.

- Keep indoors in a dry, cool place. The components' aging process will be accelerated by exposure to sunlight and temperature extremes, both hot and cold, and may permanently damage the battery.

- Keep chemicals and heat sources (stoves, radiators, etc.) away from the mower, charging station, and power supply.

- Store the power supply in an area with good ventilation and shield it from moisture.



WARNING

Unplug the power supply from the power socket if a thunderstorm is predicted. Cut off all wires and cables that are attached to the charging station. When there is no longer a chance of thunder, reconnect.

Extra requirements for winter storage.

The mower: Clean the mower thoroughly before storage. Check the components subject to wear such as the blades. Repair or replace them if they are in poor condition. Store the mower in a dry and frost-free place, while standing on all wheels, preferably in the original packaging.

The charging station: Disconnect from the charging station and unplug the power supply from the power outlet. Keep the charging station out of direct sunlight and bring it inside.

5.7 Recycling and End-of-life Disposal

This product is NOT household waste. Get in touch with your municipality, point of sale, or domestic waste service for information on recycling.



WARNING

This product should not be disposed of in a landfill, burned, or combined with regular household trash. It is possible for danger or severe harm to result from the electrical components.

6. FAQ and Troubleshooting

6.1 FAQ*

▪ Does my garden need to have complete Wi-Fi coverage?

If possible, try to ensure complete Wi-Fi coverage in the garden.

If complete coverage is not possible, at least ensure that there is Wi-Fi coverage near the base station and the charging station. Ensuring Wi-Fi coverage around charging stations is essential for robot to perform OTA updates while charging. Similarly, Wi-Fi coverage near base station ensures that the base station can undergo OTA updates, and also allows robot to upload and receive certain information.

*Note that when binding the base station, it is essential to ensure that the machine is connected to the internet.

▪ Can the base station and charging station be moved after the map is created?

The charging station can be moved before mapping, but once the map is created, it cannot be moved, or else the machine cannot return and work properly.

After the map is completed, the base station cannot be moved; otherwise, a new map needs to be created.

▪ During mapping, what is the maximum distance between Bluetooth and the machine?

During mapping, the machine connects to the smartphone via Bluetooth. Please ensure that you stay within a distance of no more than 3 ft from the machine during mapping.

▪ After pressing the stop button on the machine, how can I restart it?

For safety reasons, when the machine is in stop mode, to restart, press "start+ok" or "home+ok" on the screen.

▪ Meaning of Standard, Stealth, and Custom Modes in Cutting Patterns:

Standard Mode: The machine follows the same trajectory during each operation, efficiently planning mowing paths in an orderly linear fashion. This results in visible vertical stripes on the lawn.

Stealth Mode: In contrast to the standard mode, the machine still performs linear cutting but avoids the same trajectory every time. After several mowing cycles, the vertical stripes on the lawn disappear, leaving no visible traces of the machine's operation.

Custom Mode: The machine operates in a user-defined direction after leaving the charging station. After a few cutting cycles, the lawn will show the customized pattern set by the user.

▪ Can the Machine Cut the Borders?

After completing overall mowing, the machine will perform one additional border cutting.

▪ How Do I Know if the Robot/Base Station Software Needs an Update?

You will receive notifications in the app if there are new software updates.

• **Can I Upgrade the Machine Using a USB Flash Drive?**

Currently not allowed or recommended.

• **Do I Need to Bring the RTK Base Station Indoors in Winter?**

No.

• **How Should I Store the Machine in Winter?**

It is recommended to store the machine indoors during winter. Before storage, ensure the machine is fully charged and turned off.

• **Can I Wash the Machine with Water?**

Ensure all screws are tightly secured before cleaning the machine.

Use a regular water hose for cleaning; avoid using a high-pressure water gun to prevent potential damage.

• **How Often Should I Replace the Blades?**

For lawns that haven't been serviced by the robotic lawnmower before and have longer grass, consider replacing the blades every 1-2 months. In the case of continuous use for lawns where the grass length remains consistently controlled, the blades are expected to last for an extended period due to the maintained grass height.

• **What if I Forget the Machine Password?**

If the machine is bound to the app, reset the password within the app.

If not bound, contact customer service to reset the password.

• **What Happens If I Enter the Wrong Password Continuously?**

After 10 consecutive wrong password attempts, the screen will display "LOCK." Keep the machine powered on and wait for 15 minutes to enter the password again.

**More questions please refer to our official website.*

6.2 Data Privacy

(1) Processing of personal data within Platform X

Who and why?

When you register for and use Sunseeker's Platform X, Sunseeker (or "we"), as the controller, will process your personal data. We will process your personal data in order to:

Provide you with Platform X connection or to make you an offer for such service. The legal basis is that the processing is necessary for the performance of the contract that you have entered into with us, or to take steps prior to entering into a contract with us.

Further develop and improve our products and services. The legal basis is our legitimate interest in developing and improving our products and services.

Enable connectivity of Platform X (Internet of Things): use partner integrations (for example smart assistants, including voice enabled devices); use connectivity

platforms to connect Platform X to third party devices, apps, and services; and build your own smart home integration. The legal basis is that the processing is necessary for the performance of the contract that you have entered into with us.

Provide you with relevant information relating to your Platform X experience. The legal basis is our legitimate interest to keep you informed of your specific products and services and its features.

Provide you with support and troubleshooting regarding Platform X. The legal basis is that the processing is necessary for the performance of the contract that you have entered into with us.

if you have given us your consent (in which case the legal basis is your consent), we may also process your personal data for the following purposes:

Send you customized advertisements and newsletters about our products and services.

Send you customer surveys and analyze the input you provide as further detailed in such communication.

Your data will be processed for as long as it is required by Sunseeker to fulfil the above-mentioned purposes, but under no circumstances for longer than the applicable laws allow.

What personal data do we process?

We may process the following personal data:

personal details: first and last name, nationality, language preferences;

contact details: email address, postal address;

account information: account age, password, account number;

data related to the Platform X Intelligent Mapping: area names of maps, GPS coordinates;

GPS position/location data of the lawn mower;

other data related to your Platform X: mower name, pairing names, actions triggered through the use of partner integrations; and device information.

Use of location data

Some of our services only work if we can determine the location of your mower (e.g. weather display). When you share your mower location with us, the data is stored as part of your profile and may be sent to third parties in pseudonymized form for the purposes of providing the relevant service (e.g. to park the mower in case of heavy rain).

Sunseeker Intelligent Mapping and its related services (e.g. generation of a lawn map, live position, etc.) only work if the mower sends us its geographic coordinates. The data is stored as part of your profile and used to provide the services, to find solutions to problems and, after the data has been anonymized, for the further development of the technology. Sunseeker Intelligent Mapping uses a third-party provider, Google, to display the map data.

6.3 Troubleshooting

▪ Possible reasons for the machine stopping in the middle of the field:

- (1) The machine is stuck in a pit on the field. Take the machine out of the pit and clean the wheels to prevent them from being covered in mud.
- (2) Poor RTK signal. Make sure the area is open. If not, designate it as a restricted area.
- (3) Failed return to charging station.
- (4) Failed outbound positioning. Ensure that the placement of the base station meets the requirements.

▪ Reasons for the machine to automatically return:

- (1) Low battery power.
- (2) Completion of the entire garden mowing.
- (3) If there are unfinished areas on the map but the machine returns, it is because there are obstacles or poor signal in that area preventing the completion of mowing.

▪ Reasons for failed machine return:

- (1) Ensure that the QR code on the charging station is placed correctly and clean. Make sure the machine's camera is unobstructed.
- (2) Ensure that there are no obstacles 5 ft in front of the charging station.
- (3) Ensure that there are no strong light sources or reflections near the charging station that may affect the QR code.
- (4) Changing the position of the charging station or base station can also cause the machine to fail to return. In such cases, a new mapping is required.

▪ Reasons for the machine going out of bounds:

- (1) Poor boundary signal. Ensure that there are no obstructions above the boundary. If the machine consistently goes out of bounds in the same location, designate that area as a restricted zone.
- (2) The virtual boundary is set too close to the edge. If there is a height difference at the boundary, ensure that there is a distance of at least 6 inches between the machine's virtual boundary and the actual field boundary.
- (3) The machine's wheels are covered with a large amount of mud or grass, which may reduce traction or even cause a loss of traction. Clean the wheels.

▪ Machine still working during rain/ rain sensor triggering in dry conditions:

- (1) Confirm in the app whether the rain sensor is turned on/off.
- (2) Check if the rain sensor is blocked or clean.

▪ Blade obstruction:

- (1) Clean the debris from the cutting blade.
- (2) If the grass on the field is too long, use a regular lawnmower to cut it to the allowed length range.

- (3) It's advisable to cut a length that is no more than half of the total length each time.
- (4) Avoid cutting grass in rainy weather as wet grass is difficult to cut, resulting in poor cutting quality and sticking to the underside of the machine. It is recommended to set a rain delay of at least 4 hours.

▪ Machine not following the schedule:

- (1) Ensure the machine's time settings are correct.
- (2) Check if the rain sensor is triggered.
- (3) No power supply.
- (4) The schedule was not saved correctly; check the schedule in the app.
- (5) The machine may be performing a temporary task triggered manually.

▪ Machine positioning failure:

- (1) Check if all four lights on the base station are green.
- (2) Check if the base station is placed as required.
- (3) Check if there are no obstacles 5 ft in front of the charging station.
- (4) After completing the above checks, place the machine back in the charging station and let it start from there.
- (5) If it still doesn't work, restart the machine.

7. Important Information

7.1 Limited Warranty

7.1 Limited Warranty

We offer a 2-year warranty. Before initiating a warranty claim, we strongly ask you to check the FAQ and Troubleshooting section of the user manual first. Our dedicated customer support is also here to help. To initiate guarantee claims, provide a proof of purchase, including a valid receipt displaying the date and place of purchase.

Our warranty does not cover:

Parts that are subject to normal wear and tear such as ground stakes, cutting discs, battery.

7.2 Disclaimers

We provide customers with after-sale services, excluding the following circumstances:

1. Crashes damage caused by non-manufacturing factors, including but not limited to, user errors.
2. Damage caused by unauthorized modification, disassembly, or shell opening not in accordance with official instructions or manuals.
3. Damage caused by improper installation, incorrect use, or operation not in accordance with official instructions or manuals.
4. Damage caused by a non-authorized service provider.

5. Damage caused by unauthorized modification of circuits and/or mismatch or misuse of the battery and charger.

6. Damage caused by users who do not follow instructions and manual recommendations.

7. Damage caused by operation in bad lawn conditions (i.e. large areas of puddles when restricted areas are not properly set, locations with abundance of stones covering lawn surface, etc.)

8. Damage caused by operating the product in environments with electromagnetic interference, including mining areas or proximity to radio transmission towers, high-voltage wires, substations, etc.

9. Damage caused by operating the product in environments suffering from interference from other wireless devices, such as transmitters, video-downlinks, Wi-Fi signals, etc.

10. Damage caused by reliability or compatibility issues when using unauthorized third-party parts.

11. Damage caused by operating the unit with a low-charged or defective battery.

12. Damage caused by unpredictable factors such as car collisions, wild animal attacks, floods, etc.

This content is subject to change without prior notice.

7.3 Contact Information

For any inquiries, assistance, or support regarding your Sunseeker gardening tools, please feel free to reach out to us using the following contact details:

Indian Trail Office: Toll-Free: 833-822-0146

Email Support: customersupport@sunseekertools.com

Mailing Address:

Sunseeker Tools

311 Post Office Dr, Suite 315

Indian Trail, NC 28079

Our dedicated customer support team is ready to assist you with any questions or concerns you may have. Thank you for choosing Sunseeker Tools—we're here to help!

FCC Statement

This device complies with part 15 of the FCC rules. Operation is subject to the following two conditions:

(1) this device may not cause harmful interference, and (2) this device must accept any interference received, including interference that may cause undesired operation. Changes or modifications not expressly approved by the party responsible for compliance could void the user's authority to operate the equipment.

NOTE: This equipment has been tested and found to comply with the limits for a Class B digital device, pursuant to part 15 of the FCC Rules. These limits are designed to provide reasonable protection against harmful interference in a residential installation. This equipment generates uses and can radiate radio frequency energy and, if not installed and used in accordance with the instructions, may cause harmful interference to radio communications. However, there is no guarantee that interference will not occur in a particular installation. If this equipment does cause harmful interference to radio or television reception, which can be determined by turning the equipment off and on, the user is encouraged to try to correct the interference by one or more of the following measures:

- Reorient or relocate the receiving antenna.
- Increase the separation between the equipment and receiver.
- Connect the equipment into an outlet on a circuit different from that to which the receiver is connected.
- Consult the dealer or an experienced radio/TV technician for help.
- To satisfy FCC RF exposure requirements, a separation distance of 20 cm or more should be maintained between the antenna of this device and persons during device operation. To ensure compliance, operations at closer than this distance is not recommended.

WARNING for button cell or coin battery:

- a) Remove and immediately recycle or dispose of used batteries according to local regulations and keep away from children.
- b) Do NOT dispose of batteries in household trash or incinerate.
- c) Even used batteries may cause severe injury or death.
- d) Call a local poison control center for treatment information.
- e) Battery type: CR2032.
- f) Nominal voltage: 3.0 Vdc.
- g) Non-rechargeable batteries are not to be recharged.
- h) Do not force discharge, recharge, disassemble, heat above (manufacturer's specified temperature rating) or incinerate. Doing so may result in injury due to venting, leakage or explosion resulting in chemical burns.
- i) The product contains non-replaceable button cell

