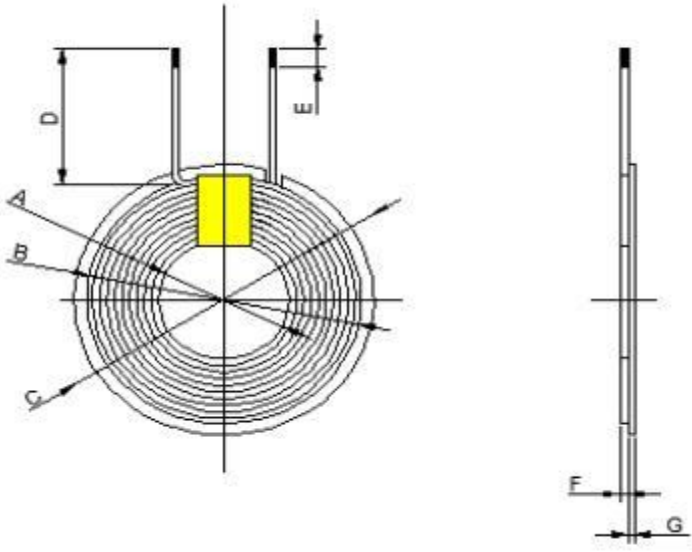
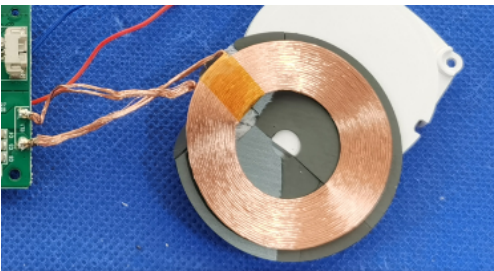

Shenzhen tianxia technology co.,ltd Specification

Document number		name	Bonding mode of wireless charging and transmitting transparent module					
Product size	$\Phi 40*\Phi 5*H2.5$		Bonding mode	Hot air self-adhesive				
			A	20.5 ± 0.5				
			B	39.0 ± 1.0				
			C	40.0 ± 0.5				
			D	28 ± 2				
			E	4M AX				
			F	1.1 ± 0.1				
			G	1.3 ± 0.1				
			H	2.5 ± 0.1				
						unit: MM		
				0.08*80 strands of hot air line	Winding mode	Single-wire winding type	remarks	Coil is counterclockwise direction
	11 Ts							
	$\Phi 40*\Phi 5*0.6$	$6.5\pm 10\%$						
	$\Phi 39.0*20.5$	Test frequency			Test mode			
Opinion table								
Draw up of from	ZhangYan	check	LuoYongjun	confirm	LuoYongjun	date	20221104	