



# FCC TEST REPORT

## FCC ID:2BF4I-OPTIMUSC

**Report Number**..... : ZHT-240314008E-3

Date of Test..... : Mar. 14, 2024 to Apr. 10, 2024

Date of issue..... : Apr. 10, 2024

Test Result..... : PASS

**Testing Laboratory**..... : Guangdong Zhonghan Testing Technology Co., Ltd.

Address ..... : Room 104, Building 1, Yibaolai Industrial Park, Qiaotou Community, Fuhai Street, Bao'an District, Shenzhen, Guangdong, China

**Applicant's name** ..... : TECH FRIENDS INC.

Address ..... : 2225 EAST HIGHLAND DRIVE, JONESBORO, AR 72401

**Manufacturer's name** ..... : HOPELAND DIGITAL (SHENZHEN) CO., LTD

Address ..... : RM501, BLOCK B, DEFENGYUAN INNOVATION VALLEY, NEIHUAN RD, SANWEI, HANGCHENG STREET, BAO'AN DISTRICT, SHENZHEN, CHINA

**Test specification:**

Standard..... : FCC Part 15 Subpart E 15.407  
KDB789033 D02 General U-NII Test Procedures New Rules v02r01

Test procedure..... : ANSI C63.10:2013

Non-standard test method ..... : N/A

This device described above has been tested by ZHT, and the test results show that the equipment under test (EUT) is in compliance with the IC requirements. And it is applicable only to the tested sample identified in the report.

This report shall not be reproduced except in full, without the written approval of ZHT, this document may be altered or revised by ZHT, personal only, and shall be noted in the revision of the document.

**Product name**..... : PCBA

Trademark ..... : /

Model/Type reference..... : Optimus-C-8000, Optimus-C-8001

Model difference..... : Optimus-C-8000 is tested model, other models are derivative models .The models are identical in circuit, only different on the model names. So the test data of Optimus-C-8000 can represent the remaining models.

Ratings..... : Input: DC 5V, 2A or DC 3.8V by battery



Testing procedure and testing location:

Testing Laboratory.....: Guangdong Zhonghan Testing Technology Co., Ltd.

Address.....: Room 104, Building 1, Yibaolai Industrial Park, Qiaotou Community, Fuhai Street, Bao'an District, Shenzhen, Guangdong, China

Tested by (name + signature).....: Leon Li

*Leon Li*

Reviewer (name + signature).....: Baret Wu

*Baret Wu*

Approved (name + signature).....: Levi Lee

*Levi Lee*

Table of Contents

Page

1. VERSION .....	5
2.SUMMARY OF TEST RESULTS .....	6
2.1 TEST FACILITY .....	7
2.2 MEASUREMENT UNCERTAINTY .....	7
3. GENERAL INFORMATION .....	8
3.1 GENERAL DESCRIPTION OF EUT .....	8
3.3 BLOCK DIGRAM SHOWING THE CONFIGURATION OF SYSTEM TESTED .....	11
3.4 DESCRIPTION OF SUPPORT UNITS(CONDUCTED MODE) .....	11
3.5 EQUIPMENTS LIST FOR ALL TEST ITEMS .....	12
4.EMC EMISSION TEST .....	14
4.1 CONDUCTED EMISSION MEASUREMENT .....	14
4.1.1 POWER LINE CONDUCTED EMISSION Limits .....	14
4.1.2 TEST PROCEDURE .....	14
4.1.3 DEVIATION FROM TEST STANDARD .....	14
4.1.4 TEST SETUP .....	15
4.1.5 EUT OPERATING CONDITIONS .....	15
4.1.6 TEST RESULTS .....	16
4.2 RADIATED EMISSION MEASUREMENT .....	18
4.2.1 APPLICABLE STANDARD .....	18
4.2.2 CONFORMANCE LIMIT .....	18
4.2.3 MEASURING INSTRUMENTS .....	18
4.2.4 TEST CONFIGURATION .....	19
4.2.5 TEST PROCEDURE .....	20
5.POWER SPECTRAL DENSITY TEST .....	25
5.1 APPLIED PROCEDURES / LIMIT .....	25
5.2 TEST PROCEDURE .....	26
5.3 DEVIATION FROM STANDARD .....	26
5.4 TEST SETUP .....	26
5.5 EUT OPERATION CONDITIONS .....	26
5.6 TEST RESULTS .....	27
6. 26DB & 6DB &99% EMISSION BANDWIDTH .....	28
6.1 APPLIED PROCEDURES / LIMIT .....	28
6.2 TEST PROCEDURE .....	28
6.3 EUT OPERATION CONDITIONS .....	29
6.4 TEST RESULTS .....	29
7.MAXIMUM CONDUCTED OUTPUT POWER .....	30
7.1 PPLIED PROCEDURES / LIMIT .....	30

**Table of Contents**

**Page**

7.2 TEST PROCEDURE .....	31
7.3 DEVIATION FROM STANDARD .....	31
7.4 TEST SETUP .....	32
7.5 EUT OPERATION CONDITIONS .....	32
7.6 TEST RESULTS .....	32
8.OUT OF BAND EMISSIONS .....	33
8.1 APPLICABLE STANDARD .....	33
8.2 TEST PROCEDURE .....	34
8.3 DEVIATION FROM STANDARD .....	34
8.4 TEST SETUP .....	34
8.5 EUT OPERATION CONDITIONS .....	34
8.6 TEST RESULTS .....	34
9.SPURIOUS RF CONDUCTED EMISSIONS .....	35
9.1 CONFORMANCE LIMIT .....	35
9.3 TEST SETUP .....	35
9.4 TEST PROCEDURE .....	35
9.5 TEST RESULTS .....	36
10.ANTENNA REQUIREMENT .....	38
11. TEST SETUP PHOTO .....	39
12. EUT CONSTRUCTIONAL DETAILS .....	39



1. VERSION

Report No.	Version	Description	Approved
ZHT-240314008E-3	Rev.01	Initial issue of report	Apr. 10, 2024



Test procedures according to the technical standards:

FCC Part15 (15.407) , Subpart E			
Standard Section	Test Item	Judgment	Remark
15.209(a), 15.407 (b)(1) 15.407 (b)(4)	Spurious Radiated Emissions	PASS	
15.207	Conducted Emission	PASS	
15.407 (a)(12)	26 dB and 99% Emission Bandwidth	PASS	
15.407(e)	6 dB bandwidth	PASS	
15.407 (a)(1) 15.407 (a)(3)	Maximum Conducted Output Power	PASS	
2.1051, 15.407(b)(1) 15.407(b)(4)	Band Edge	PASS	
15.407 (a)(1) 15.407 (a)(3)	Power Spectral Density	PASS	
2.1051, 15.407(b)	Spurious Emissions at Antenna Terminals	PASS	
15.203	Antenna Requirement	PASS	
15.407(g)	Frequency Stability Measurement	PASS	

NOTE:

- (1) " N/A" denotes test is not applicable in this Test Report
- (2) The product meets the requirements of 15.407 (C) standard Operation in the absence of information to the transmit:

While the EUT is not transmitting any information, the EUT can automatically discontinue transmission and become standby mode for power saving. The EUT can detect the controlling signal of ASK message transmitting from remote device and verify whether it shall resend or discontinue transmission. (manufacturer declare )



## 2.1 TEST FACILITY

Guangdong Zhonghan Testing Technology Co., Ltd.

Add. : Room 104, Building 1, Yibaolai Industrial Park, Qiaotou Community, Fuhai Street, Bao'an District, Shenzhen, Guangdong, China

C Registered No.: 29832

CAB identifier: CN0143

## 2.2 MEASUREMENT UNCERTAINTY

The reported uncertainty of measurement  $y \pm U$ , where expanded uncertainty  $U$  is based on a standard uncertainty multiplied by a coverage factor of  $k=2$ , providing a level of confidence of approximately 95%.

No.	Item	Uncertainty
1	3m chamber Radiated spurious emission(30MHz-1GHz)	U=4.3dB
2	3m chamber Radiated spurious emission(1GHz-18GHz)	U=4.5dB
3	3m chamber Radiated spurious emission(18GHz-40GHz)	U=3.34dB
4	Conducted Adjacent channel power	U=1.38dB
5	All emissions radiated(9k-30MHz)	U=4.68dB
6	Conducted output power uncertainty Above 1G	U=1.576dB
7	Conducted output power uncertainty below 1G	U=1.28dB
8	humidity uncertainty	U=5.3%
9	Temperature uncertainty	U=0.59℃
10	Radiated disturbance(30MHz-1000MHz)	U=4.8dB
11	Radiated disturbance(1GHz-6GHz)	U=4.9dB
12	Radiated disturbance(1GHz-18GHz)	U=5.0dB
13	Occupied Bandwidth	U=4.96dB
14	RF Power Density	U=0.77dB



3.1 GENERAL DESCRIPTION OF EUT

Product Name:	PCBA	
Test Model No.:	Optimus-C-8000	
Product Description	IEEE 802.11 WLAN Mode Supported	<input checked="" type="checkbox"/> 802.11a/n/ac (20MHz channel bandwidth) <input checked="" type="checkbox"/> 802.11n/ac (40MHz channel bandwidth) <input checked="" type="checkbox"/> 802.11ac(80MHz channel bandwidth)
	Data Rate	802.11a: 6,9,12,18,24,36,48,54Mbps; 802.11n/ac(HT20/HT40):MCS0-MCS7; 802.11ac(VHT80):NSS1, MCS0-MCS9
	Modulation	OFDM with BPSK/QPSK/16QAM/64QAM/256QAM for 802.11a/n/ac;
	Operating Frequency Range	<input checked="" type="checkbox"/> 5180-5240MHz for 802.11a/n(HT20)/ac20; 5190-5230MHz for 802.11n(HT40)/ac40; 5210MHz for 802.11 ac80; <input checked="" type="checkbox"/> 5745-5825 MHz for802.11a/n(HT20)/ac20; 5755-5795 MHz for 802.11a/n(HT40)/ac40; 5775MHz for 802.11 ac80;
	Number of Channels	<input checked="" type="checkbox"/> 4 channels for 802.11a/n20/ac20 in the 5180-5240MHz band ; 2 channels for 802.11 n40/ac40 in the 5190-5230 MHz band ; 1 channels for 802.11 ac80 in the 5210MHz band ; <input checked="" type="checkbox"/> 5 channels for 802.11a/n20/ac20 in the 5745-5825MHz band ; 2 channels for 802.11 n40/ac40 in the 5755-5795 MHz band ; 1 channels for 802.11 ac80 in the 5775MHz band ;
Channel List	Please refer to the Note 2.	
Antenna Type and Antenna gain:	5.2GWIFI FPC Antenna, 3.19dBi 5.8GWIFI FPC Antenna, 3.44dBi	
Worst Case:	5.2G WIFI 802.11a	
Power supply:	Input: DC 5V, 2A or DC 3.8V by battery	
SWITCHING POWER ADAPTER:	/	
Sample Number:	240314008E-1#	





802.11a/n( 20MHz) Frequency Channel							
Channel	Frequency (MHz)	Channel	Frequency (MHz)	Channel	Frequency (MHz)	Channel	Frequency (MHz)
36	5180	44	5220	149	5745	157	5785
40	5200	48	5240	153	5765	161	5805
165	5825						

802.11n(40MHz) Frequency Channel

802.11n (40MHz)Frequency Channel							
Channel	Frequency (MHz)	Channel	Frequency (MHz)	Channel	Frequency (MHz)	Channel	Frequency (MHz)
38	5190	46	5230	151	5755	159	5795

802.11ac(80MHz) Frequency Channel

Channel	Frequency (MHz)
42	5210
155	5775

### 3.2 DESCRIPTION OF TEST MODES

Transmitting mode	Keep the EUT in continuously transmitting mode
Remark: During the test, the duty cycle >98%, the test voltage was tuned from 85% to 115% of the nominal rated supply voltage, and found that the worst case was under the nominal rated supply condition. So the report just shows that condition's data.	

Pretest Mode	Description
Mode 1	802.11a / n20/ac 20/ CH36/ CH40/ CH48/ CH149 / CH157 / CH165
Mode 2	802.11n 40/ac40 CH38/ CH46/ CH151/ CH159
Mode 3	802.11 ac80 CH42/ CH155
Mode 4	Link Mode

Conducted Emission	
Final Test Mode	Description
Mode 4	Link Mode

For Radiated Emission	
Final Test Mode	Description
Mode 1	802.11a / n20/ac 20/ CH36/ CH40/ CH48/ CH149 / CH157 / CH165
Mode 2	802.11n 40/ac40 CH38/ CH46/ CH151/ CH159
Mode 3	802.11 ac80 CH42/ CH155

Note:

(1) The measurements are performed at all Bit Rate of Transmitter, the worst data was reported.



3.3 BLOCK DIGRAM SHOWING THE CONFIGURATION OF SYSTEM TESTED

Radiated Emission

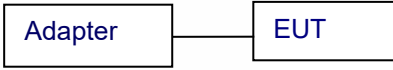

Conducted Spurious

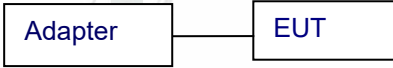

3.4 DESCRIPTION OF SUPPORT UNITS(CONDUCTED MODE)

The EUT has been tested as an independent unit together with other necessary accessories or support units. The following support units or accessories were used to form a representative test configuration during the tests.

Item	Equipment	Mfr/Brand	Model/Type No.	Series No.	Note

Item	Shielded Type	Ferrite Core	Length	Note

Note:

- (1) The support equipment was authorized by Declaration of Confirmation.
- (2) For detachable type I/O cable should be specified the length in cm in 『Length』 column.
- (3) The test software is the Secure CRTPortable.exe which can set the EUT into the individual test modes.  
 802.11a/802.11n(HT20)/802.11ac(HT20) Power set point:63  
 802.11n /ac(40MHz)Power set point:44  
 802.11ac(80MHz)Power set point:44



## 3.5 EQUIPMENTS LIST FOR ALL TEST ITEMS

## Radiation Test equipment

Item	Equipment	Manufacturer	Model	Last Cal.	Next Cal.
1	Receiver	R&S	ESCI	May 12, 2023	May 11, 2024
2	Loop antenna	EMCI	LAP600	May 12, 2023	May 11, 2024
3	Amplifier	Schwarzbeck	BBV 9743 B	May 12, 2023	May 11, 2024
4	Amplifier	Schwarzbeck	BBV 9718 B	May 12, 2023	May 11, 2024
5	Bilog Antenna	Schwarzbeck	VULB9162	May 17, 2023	May 16, 2024
6	Horn Antenna	Schwarzbeck	BBHA9120D	May 17, 2023	May 16, 2024
7	Horn Antenna	A.H.SYSTEMS	SAS574	May 12, 2023	May 11, 2024
8	Amplifier	AEROFLEX	100KHz-40GHz	May 12, 2023	May 11, 2024
9	Spectrum Analyzer	R&S	FSV40	May 12, 2023	May 11, 2024
10	966 Anechoic Chamber	EMToni	9m6m6m	Nov. 25, 2021	Nov. 24, 2024
11	Spectrum Analyzer	KEYSIGHT	N9020A	May 12, 2023	May 11, 2024
12	WIDBAND RADIO COMMUNICATION TESTER	R&S	CMW500	May 12, 2023	May 11, 2024
13	Single Generator	Agilent	N5182A	May 12, 2023	May 11, 2024
14	Power Sensor	MWRftest	MW100-RFCB	May 12, 2023	May 11, 2024
15	Audio analyzer	R&S	UPL	May 12, 2023	May 11, 2024
16	Single Generator	R&S	SMB100A	May 12, 2023	May 11, 2024
17	Power Amplifier Shielding Room	EMToni	2m3m3m	Nov. 25, 2021	Nov. 24, 2024

Conduction Test equipment

Equipment	Manufacturer	Model	Last Cal.	Next Cal.
Receiver	R&S	ESCI	May 12, 2023	May 11, 2024
LISN	R&S	ENV216	May 12, 2023	May 11, 2024
ISN CAT 6	Schwarzbeck	NTFM 8158	May 12, 2023	May 11, 2024
ISN CAT 5	Schwarzbeck	CAT5 8158	May 12, 2023	May 11, 2024
Capacitive Voltage Probe	Schwarzbeck	CVP 9222 C	May 12, 2023	May 11, 2024
Current Transformer Clamp	Schwarzbeck	SW 9605	May 12, 2023	May 11, 2024
CE Shielding Room	EMToni	9m4m3m	Nov. 25, 2021	Nov. 24, 2024



#### 4.EMC EMISSION TEST

##### 4.1 CONDUCTED EMISSION MEASUREMENT

Test Requirement:	FCC Part15 C Section 15.207
Test Method:	ANSI C63.10:2013
Test Frequency Range:	150KHz to 30MHz
Receiver setup:	RBW=9KHz, VBW=30KHz, Sweep time=auto

##### 4.1.1 POWER LINE CONDUCTED EMISSION Limits

FREQUENCY (MHz)	Limit (dBuV)		Standard
	Quasi-peak	Average	
0.15 -0.5	66 - 56 *	56 - 46 *	FCC
0.50 -5.0	56.00	46.00	FCC
5.0 -30.0	60.00	50.00	FCC

Note:

(1) \*Decreases with the logarithm of the frequency.

##### 4.1.2 TEST PROCEDURE

- a. The EUT was placed 0.8 meters from the horizontal ground plane with EUT being connected to the power mains through a line impedance stabilization network (LISN). All other support equipments powered from additional LISN(s). The LISN provide 50 Ohm/ 50uH of coupling impedance for the measuring instrument.
- b. Interconnecting cables that hang closer than 40 cm to the ground plane shall be folded back and forth in the center forming a bundle 30 to 40 cm long.
- c. I/O cables that are not connected to a peripheral shall be bundled in the center. The end of the cable may be terminated, if required, using the correct terminating impedance. The overall length shall not exceed 1 m.
- d. LISN at least 80 cm from nearest part of EUT chassis.
- e. For the actual test configuration, please refer to the related Item –EUT Test Photos.

##### 4.1.3 DEVIATION FROM TEST STANDARD

No deviation

#### 4.1.4 TEST SETUP

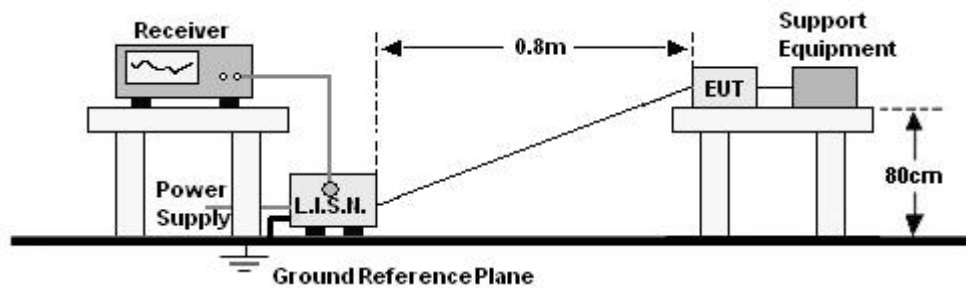

#### 4.1.5 EUT OPERATING CONDITIONS

The EUT was configured for testing in a typical fashion (as a customer would normally use it). The EUT has been programmed to continuously transmit during test. This operating condition was tested and used to collect the included data.



4.1.6 TEST RESULTS

Temperature:	24.3°C	Relative Humidity :	50%
Pressure:	101kPa	Phase :	L
Test Voltage:	AC 120V/60Hz		

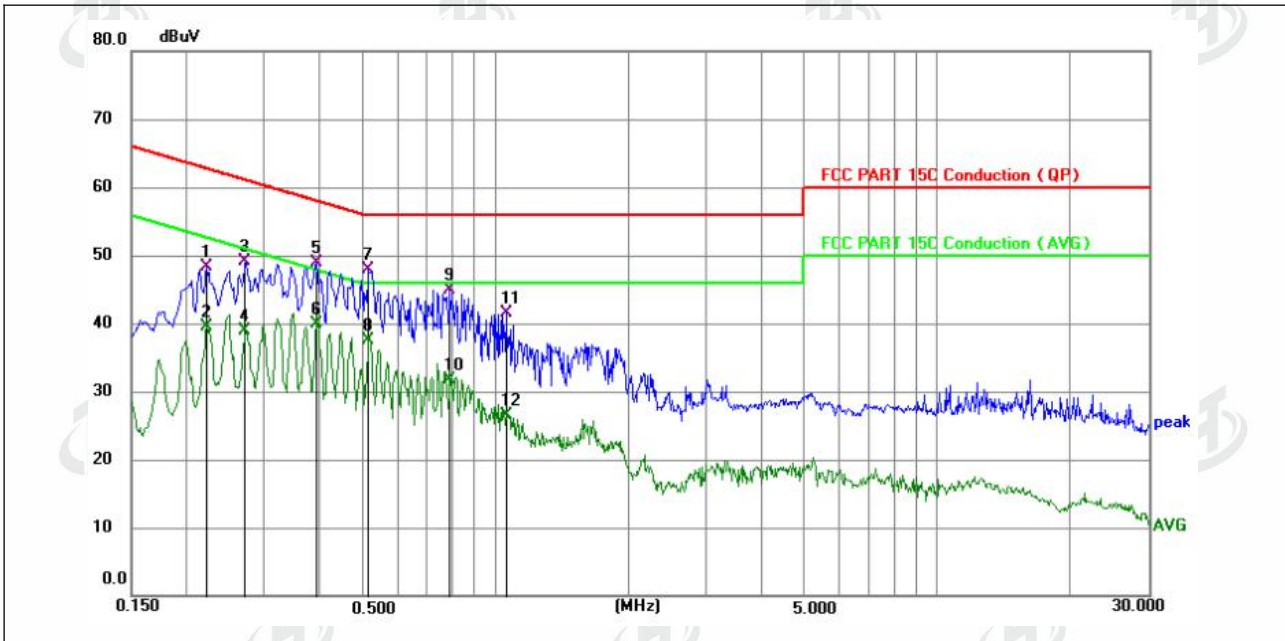

No.	Frequency (MHz)	Reading (dBuV)	Factor (dB)	Level (dBuV)	Limit (dBuV)	Margin (dB)	Detector	P/F
1	0.2220	38.31	9.91	48.22	62.74	-14.52	QP	P
2	0.2220	29.69	9.91	39.60	52.74	-13.14	AVG	P
3	0.2714	39.20	9.91	49.11	61.07	-11.96	QP	P
4	0.2714	28.97	9.91	38.88	51.07	-12.19	AVG	P
5	0.3930	38.90	9.91	48.81	58.00	-9.19	QP	P
6 *	0.3930	30.01	9.91	39.92	48.00	-8.08	AVG	P
7	0.5141	37.96	9.89	47.85	56.00	-8.15	QP	P
8	0.5141	27.53	9.89	37.42	46.00	-8.58	AVG	P
9	0.7890	35.09	9.90	44.99	56.00	-11.01	QP	P
10	0.7890	21.89	9.90	31.79	46.00	-14.21	AVG	P
11	1.0544	31.57	9.90	41.47	56.00	-14.53	QP	P
12	1.0544	16.55	9.90	26.45	46.00	-19.55	AVG	P

Notes:

1. An initial pre-scan was performed on the line and neutral lines with peak detector.
2. Quasi-Peak and Average measurement were performed at the frequencies with maximized peak emission.
3. Measurement Level = Reading level + Correct Factor
4. The test data shows only the worst case ANT 1-802.1a Low Channel:5180MHz.





Temperature:	24.3°C	Relative Humidity :	50%
Pressure:	101kPa	Phase :	N
Test Voltage:	AC 120V/60Hz		

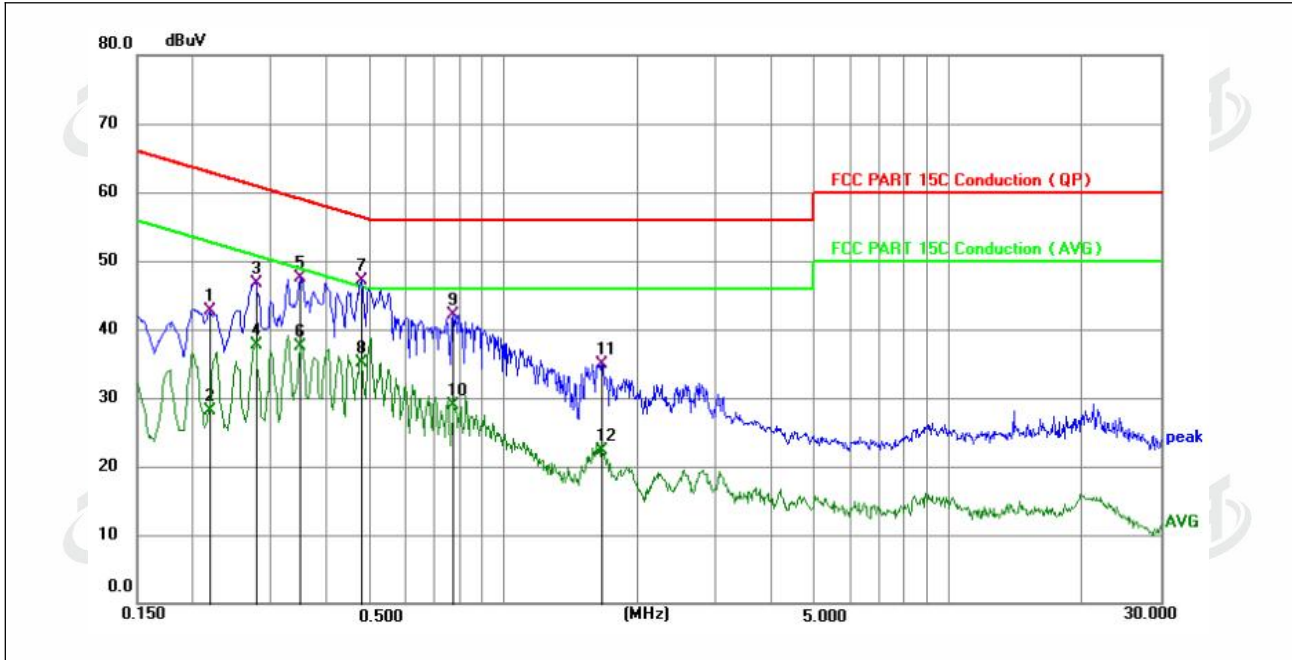

No.	Frequency (MHz)	Reading (dBuV)	Factor (dB)	Level (dBuV)	Limit (dBuV)	Margin (dB)	Detector	P/F
1	0.2174	32.72	9.91	42.63	62.92	-20.29	QP	P
2	0.2174	18.19	9.91	28.10	52.92	-24.82	AVG	P
3	0.2760	36.79	9.91	46.70	60.94	-14.24	QP	P
4	0.2760	27.70	9.91	37.61	50.94	-13.33	AVG	P
5	0.3480	37.65	9.91	47.56	59.01	-11.45	QP	P
6	0.3480	27.66	9.91	37.57	49.01	-11.44	AVG	P
7 *	0.4783	37.15	9.89	47.04	56.37	-9.33	QP	P
8	0.4783	25.23	9.89	35.12	46.37	-11.25	AVG	P
9	0.7710	32.25	9.90	42.15	56.00	-13.85	QP	P
10	0.7710	19.09	9.90	28.99	46.00	-17.01	AVG	P
11	1.6665	25.03	9.89	34.92	56.00	-21.08	QP	P
12	1.6665	12.48	9.89	22.37	46.00	-23.63	AVG	P

Notes:

1. An initial pre-scan was performed on the line and neutral lines with peak detector.
2. Quasi-Peak and Average measurement were performed at the frequencies with maximized peak emission.
3. Measurement Level = Reading level + Correct Factor
4. The test data shows only the worst case ANT 1-802.1a Low Channel:5180MHz.



## 4.2 RADIATED EMISSION MEASUREMENT

### 4.2.1 APPLICABLE STANDARD

According to FCC Part 15.407(d) and 15.209, RSS-247 6.2.1.2, RSS-Gen

### 4.2.2 CONFORMANCE LIMIT

According to FCC Part 15.407(b)(7): radiated emissions which fall in the restricted bands, as defined in §15.205(a), must also comply with the radiated emission limits specified in §15.209(a) (see §15.205(c)).

According to FCC Part 15.205, Restricted bands

MHz	MHz	MHz	GHz
0.090-0.110	16.42-16.423	399.9-410	4.5-5.15
10.495-0.505	16.69475-16.69525	608-614	5.35-5.46
2.1735-2.1905	16.80425-16.80475	960-1240	7.25-7.75
4.125-4.128	25.5-25.67	1300-1427	8.025-8.5
4.17725-4.17775	37.5-38.25	1435-1626.5	9.0-9.2
4.20725-4.20775	73-74.6	1645.5-1646.5	9.3-9.5
6.215-6.218	74.8-75.2	1660-1710	10.6-12.7
6.26775-6.26825	123-138	2200-2300	14.47-14.5
8.291-8.294	149.9-150.05	2310-2390	15.35-16.2
8.362-8.366	156.52475-156.52525	2483.5-2500	17.7-21.4
8.37625-8.38675	156.7-156.9	2690-2900	22.01-23.12
8.41425-8.41475	162.0125-167.17	3260-3267	23.6-24.0
12.29-12.293	167.72-173.2	3332-3339	31.2-31.8
12.51975-12.52025	240-285	3345.8-3358	36.43-36.5
12.57675-12.57725	322-335.4	3600-4400	(2)
13.36-13.41			

20dBc in any 100 kHz bandwidth outside the operating frequency band. In case the emission fall within the restricted band specified on 15.205(a), then the 15.209(a) limit in the table below has to be followed.

Restricted Frequency(MHz)	Field Strength ( $\mu\text{V}/\text{m}$ )	Field Strength ( $\text{dB}\mu\text{V}/\text{m}$ )	Measurement Distance
0.009~0.490	2400/F(KHz)	20 log ( $\mu\text{V}/\text{m}$ )	300
0.490~1.705	2400/F(KHz)	20 log ( $\mu\text{V}/\text{m}$ )	30
1.705~30.0	30	29.5	30
30-88	100	40	3
88-216	150	43.5	3
216-960	200	46	3
Above 960	500	54	3

### Limits of Radiated Emission Measurement(Above 1000MHz)

Frequency(MHz)	Class B ( $\text{dB}\mu\text{V}/\text{m}$ ) (at 3M)	
	PEAK	AVERAGE
Above 1000	74	54

Remark :1. Emission level in  $\text{dB}\mu\text{V}/\text{m}=20 \log (\mu\text{V}/\text{m})$

2. Measurement was performed at an antenna to the closed point of EUT distance of meters.

3. Distance extrapolation factor  $=40 \log (\text{Specific distance}/ \text{test distance})(\text{dB})$ ;

Limit line=Specific limits( $\text{dB}\mu\text{V}$ ) + distance extrapolation factor.

### 4.2.3 MEASURING INSTRUMENTS

The Measuring equipment is listed in the section 6.3 of this test report.

### 4.2.4 TEST CONFIGURATION

#### 1. For radiated emissions below 30MHz

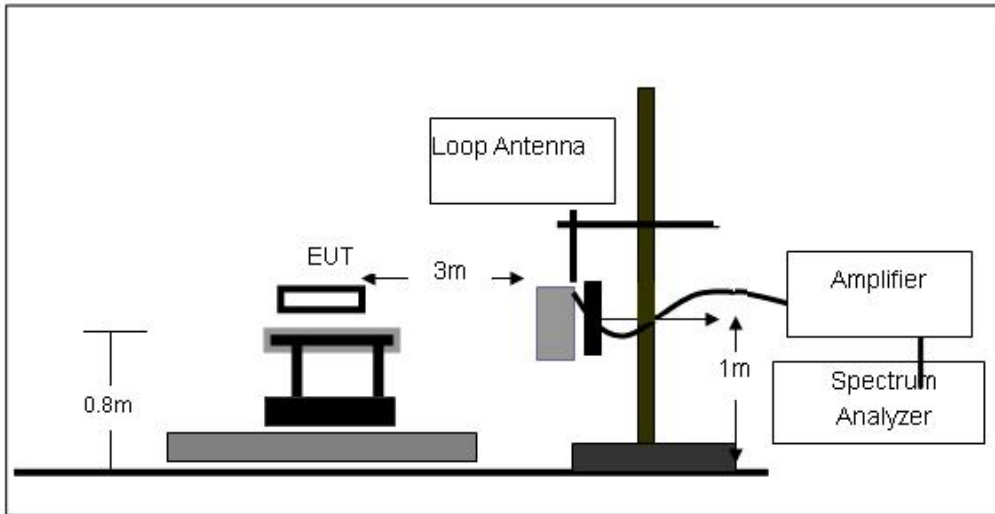

#### 2. For radiated emissions from 30MHz to 1000MHz

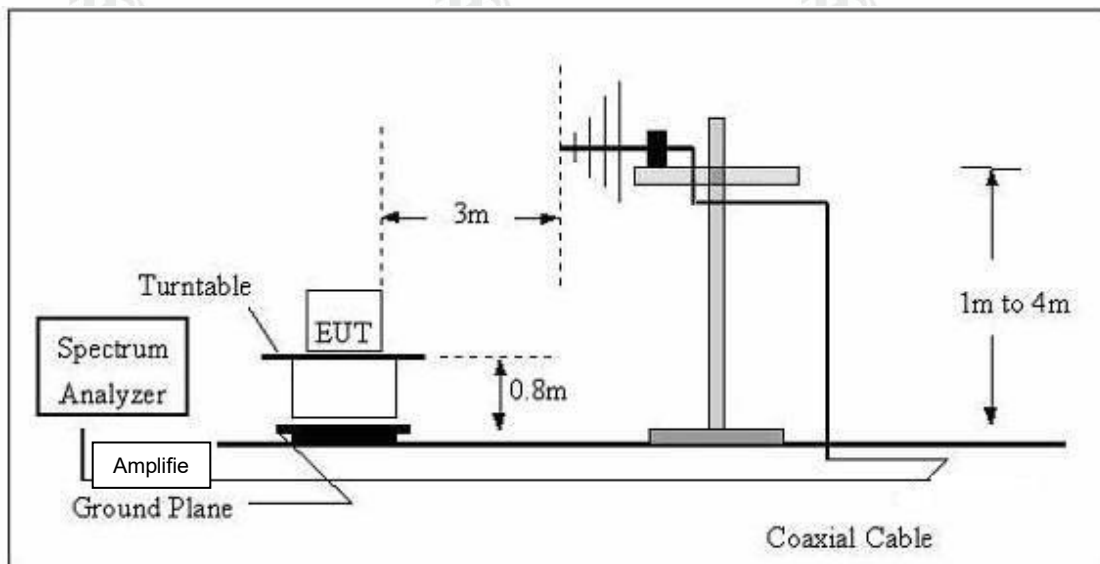

#### 3. Radiated Emission Test-Up Frequency Above 1GHz

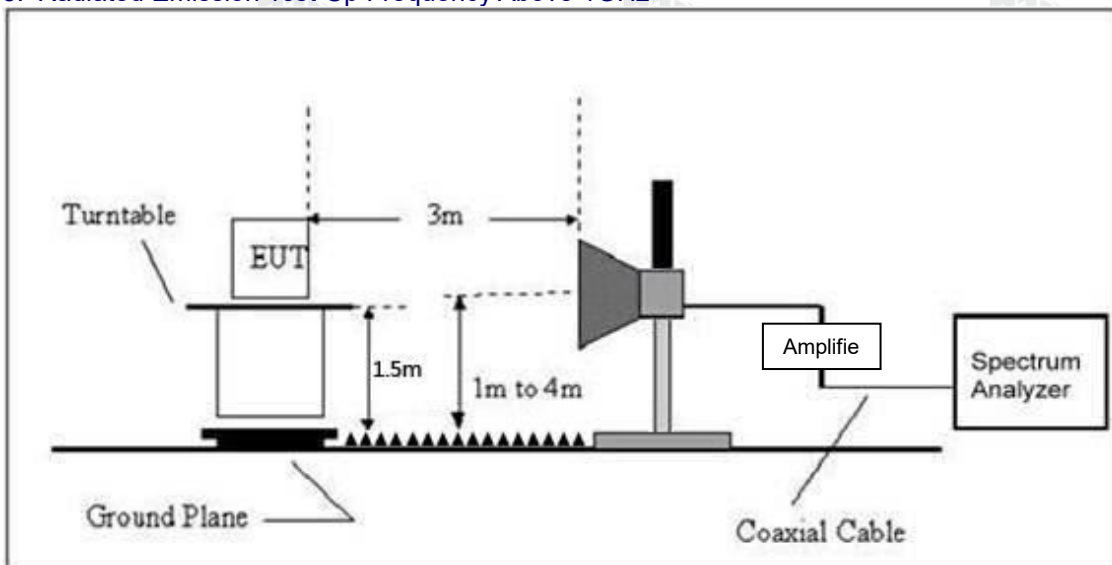



4.2.5 TEST PROCEDURE

The test site semi-anechoic chamber has met the requirement of NSA tolerance 4 dB according to the standards: ANSI C63.10-2013. The test distance is 3m. The setup is according to the requirements in Section 13.1.4.1 of ANSI C63.10-2013.

This test is required for any spurious emission that falls in a Restricted Band, as defined in Section 15.205. It must be performed with the highest gain of each type of antenna proposed for use with the EUT. Use the following spectrum analyzer settings:

Spectrum Parameter	Setting
Attenuation	Auto
Start Frequency	1000 MHz
Stop Frequency	10th carrier harmonic
RB / VB (emission in restricted band)	1 MHz / 1 MHz for Peak, 1 MHz / 10Hz for Average

Receiver Parameter	Setting
Attenuation	Auto
Start ~ Stop Frequency	9kHz~150kHz / RB 200Hz for QP
Start ~ Stop Frequency	150kHz~30MHz / RB 9kHz for QP
Start ~ Stop Frequency	30MHz~1000MHz / RB 120kHz for QP

- a. The measuring distance of at 3 m shall be used for measurements at frequency up to 1GHz. For frequencies above 1GHz, any suitable measuring distance may be used.
- b. The EUT was placed on the top of a rotating table 0.8 m for below 1GHz and 1.5m for above 1GHz the ground at a 3 meter. The table was rotated 360 degrees to determine the position of the highest radiation.
- c. The height of the equipment or of the substitution antenna shall be 0.8 m for below 1GHz and 1.5m for above 1GHz; the height of the test antenna shall vary between 1 m to 4 m. Both horizontal and vertical polarizations of the antenna are set to make the measurement.
- d. The initial step in collecting conducted emission data is a spectrum analyzer peak detector mode pre-scanning the measurement frequency range. Significant peaks are then marked and then Quasi Peak detector mode re-measured.
- e. If the Peak Mode measured value compliance with and lower than Quasi Peak Mode Limit, the EUT shall be deemed to meet QP Limits and then no additional QP Mode measurement performed.
- f. For the actual test configuration, please refer to the related Item –EUT Test Photos.

Note:

Both horizontal and vertical antenna polarities were tested and performed pretest to three orthogonal axis. The worst case emissions were reported

During the radiated emission test, the Spectrum Analyzer was set with the following configurations:

Frequency Band (MHz)	Function	Resolution bandwidth	Video Bandwidth
30 to 1000	QP	120 kHz	300 kHz
Above 1000	Peak	1 MHz	1 MHz
	Average	1 MHz	10 Hz

Note: for the frequency ranges below 30 MHz, a narrower RBW is used for these ranges but the measured value should add a RBW correction factor (RBWCF) where  $RBWCF [dB] = 10 \cdot \lg(100 [kHz]/\text{narrower RBW [kHz]})$ . , the narrower RBW is 1 kHz and RBWCF is 20 dB for the frequency 9 kHz to 150 kHz, and the narrower RBW is 10 kHz and RBWCF is 10 dB for the frequency 150 kHz to 30 MHz.

4.2.6 TEST RESULT(Between 9KHz – 30MHz)

The emission from 9 kHz to 30MHz was pre-tested and found the result was 20dB lower than the limit, and according to 15.31(o) & RSS-Gen 6.13, the test result no need to reported.



Between 30MHz – 1GHz

Temperature:	25.2°C	Relative Humidity:	50%
Pressure:	1010kPa	Polarization:	Horizontal
Test Voltage:	DC 3.8V		

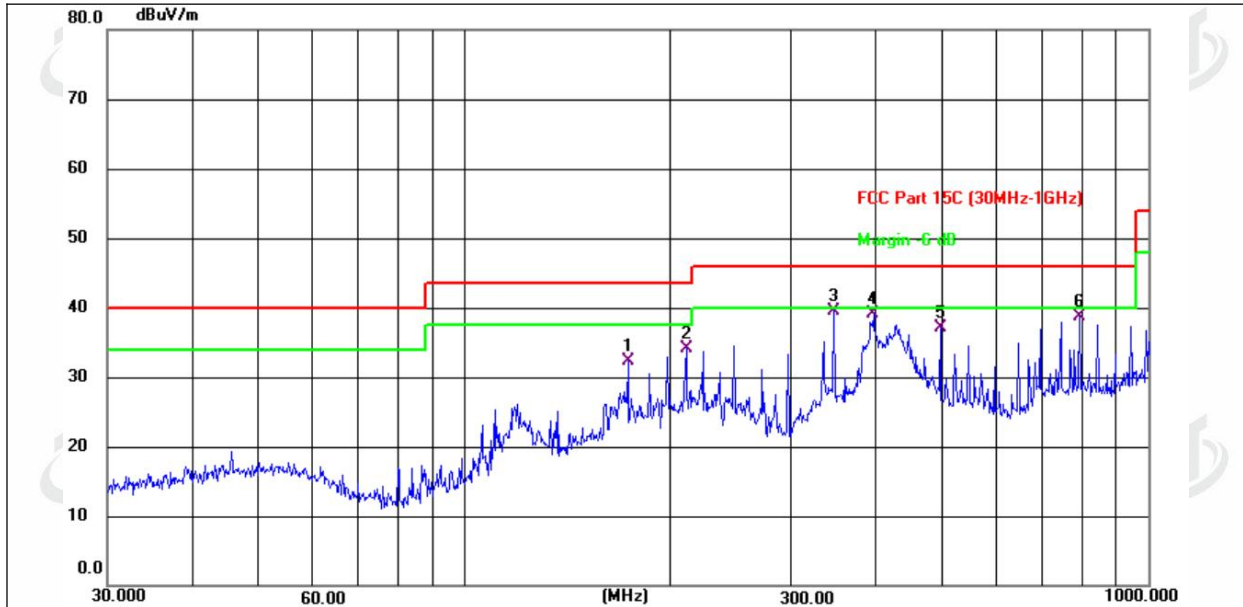

No.	Frequency (MHz)	Reading (dBuV)	Factor (dB/m)	Level (dBuV/m)	Limit (dBuV/m)	Margin (dB)	Detector
1	173.2050	45.11	-12.71	32.40	43.50	-11.10	QP
2	210.7860	44.51	-10.49	34.02	43.50	-9.48	QP
3 *	346.8091	46.47	-6.97	39.50	46.00	-6.50	QP
4	396.2412	44.96	-5.84	39.12	46.00	-6.88	QP
5	495.9343	41.30	-4.16	37.14	46.00	-8.86	QP
6	793.3960	38.10	0.59	38.69	46.00	-7.31	QP



Temperature:	25.2°C	Relative Humidity:	50%
Pressure:	1010kPa	Polarization:	Vertical
Test Voltage:	DC 3.8V		

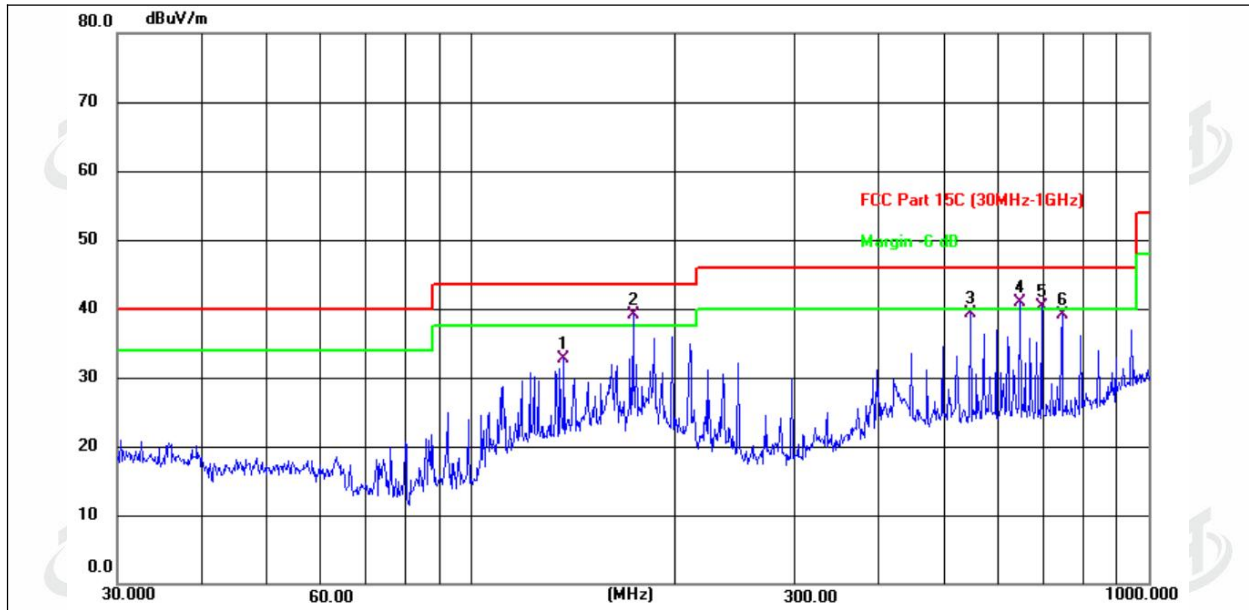

No.	Frequency (MHz)	Reading (dBuV)	Factor (dB/m)	Level (dBuV/m)	Limit (dBuV/m)	Margin (dB)	Detector
1	136.9390	46.32	-13.56	32.76	43.50	-10.74	QP
2 *	173.2050	51.72	-12.71	39.01	43.50	-4.49	QP
3	545.1825	42.48	-3.27	39.21	46.00	-6.79	QP
4 !	645.1194	42.39	-1.54	40.85	46.00	-5.15	QP
5 !	694.4174	41.07	-0.74	40.33	46.00	-5.67	QP
6	744.8660	39.22	-0.06	39.16	46.00	-6.84	QP

Remarks:

1. Final Level = Receiver Read level + Antenna Factor + Cable Loss – Preamplifier Factor
2. The emission levels of other frequencies are very lower than the limit and not show in test report.
3. The test data shows only the worst case ANT 1-802.1a Low Channel:5180MHz.



Between 1GHz – 40GHz

Temperature :	24.2°C	Relative Humidity:	54%
Pressure :	1010 hPa	Test Voltage :	DC 3.8V
Test Mode :	5.2G TX- 802.11a		

## 802.11a

Polar (H/V)	Frequency	Meter Reading	Pre-amplifier	Cable Loss	Antenna Factor	Emission Level	Limits	Margin	Detect or Type
	(MHz)	(dBuV)	(dB)	(dB)	(dB)	(dBuV/m)	(dBuV/m)	(dB)	
Low Channel:5180MHz									
V	11490.00	55.85	30.55	5.77	24.66	55.73	74	-18.27	PK
V	11490.00	41.55	30.55	5.77	24.66	41.43	54	-12.57	AV
V	17235.00	56.09	30.33	6.32	24.55	56.63	74	-17.37	PK
V	17235.00	41.59	30.33	6.32	24.55	42.13	54	-11.87	AV
H	11490.00	59.81	30.55	5.77	24.66	59.69	74	-14.31	PK
H	11490.00	44.06	30.55	5.77	24.66	43.94	54	-10.06	AV
H	17235.00	56.3	30.33	6.32	24.55	56.84	74	-17.16	PK
H	17235.00	41.26	30.33	6.32	24.55	41.8	54	-12.2	AV
Middle Channel:5200MHz									
V	11570.00	56.03	30.55	5.77	24.66	55.91	74	-18.09	PK
V	11570.00	41.37	30.55	5.77	24.66	41.25	54	-12.75	AV
V	17355.00	57.72	30.33	6.32	24.55	58.26	74	-15.74	PK
V	17355.00	43.82	30.33	6.32	24.55	44.36	54	-9.64	AV
H	11570.00	57.53	30.55	5.77	24.66	57.41	74	-16.59	PK
H	11570.00	41.46	30.55	5.77	24.66	41.34	54	-12.66	AV
H	17355.00	58.38	30.33	6.32	24.55	58.92	74	-15.08	PK
H	17355.00	41.38	30.33	6.32	24.55	41.92	54	-12.08	AV
High Channel:5240MHz									
V	11650.00	55.75	30.55	5.77	24.66	55.63	74	-18.37	PK
V	11650.00	41.14	30.55	5.77	24.66	41.02	54	-12.98	AV
V	17475.00	59.04	30.33	6.32	24.55	59.58	74	-14.42	PK
V	17475.00	44.6	30.33	6.32	24.55	45.14	54	-8.86	AV
H	11650.00	55.96	30.55	5.77	24.66	55.84	74	-18.16	PK
H	11650.00	41.46	30.55	5.77	24.66	41.34	54	-12.66	AV
H	17475.00	56.54	30.33	6.32	24.55	57.08	74	-16.92	PK
H	17475.00	44.34	30.33	6.32	24.55	44.88	54	-9.12	AV

Remark:

1. Emission Level = Meter Reading + Antenna Factor + Cable Loss – Pre-amplifier,

Margin= Emission Level - Limit

2. If peak below the average limit, the average emission was no test.

3. The amplitude of spurious emissions which are attenuated by more than 20dB below the permissible value has no need to be reported.

4. 802.11 a,802.11n20/40 of ANT have been tested,The worst mode is ANT 802.11a is recorded.



RADIATED Band EMISSION MEASUREMENT

	Polar (H/V)	Frequency (MHz)	Meter Reading (dBuV)	Pre-amplifier (dB)	Cable Loss (dB)	Antenna Factor (dB/m)	Emission level (dBuV/m)	Limit (dBuV/m)	Margin (dB)	Detector Type	Result
802.11a	Low Channel 5180MHz										
	H	5141.5	61.10	30.22	4.85	23.98	59.71	74.00	-14.29	PK	PASS
	H	5141.5	48.23	30.22	4.85	23.98	46.84	54.00	-7.16	AV	PASS
	H	5150	59.21	30.22	4.85	23.98	57.82	74.00	-16.18	PK	PASS
	H	5150	47.18	30.22	4.85	23.98	45.79	54.00	-8.21	AV	PASS
	V	5141.5	61.83	30.22	4.85	23.98	60.44	74.00	-13.56	PK	PASS
	V	5141.5	46.90	30.22	4.85	23.98	45.51	54.00	-8.49	AV	PASS
	V	5150	61.48	30.22	4.85	23.98	60.09	74.00	-13.91	PK	PASS
	V	5150	47.86	30.22	4.85	23.98	46.47	54.00	-7.53	AV	PASS
	High Channel 5240MHz										
	H	5350	59.54	30.22	4.85	23.98	58.15	74.00	-15.85	PK	PASS
	H	5350	47.85	30.22	4.85	23.98	46.46	54.00	-7.54	AV	PASS
	H	5410	59.16	30.22	4.85	23.98	57.77	74.00	-16.23	PK	PASS
	H	5410	48.59	30.22	4.85	23.98	47.20	54.00	-6.80	AV	PASS
	V	5350	60.51	30.22	4.85	23.98	59.12	74.00	-14.88	PK	PASS
	V	5350	47.52	30.22	4.85	23.98	46.13	54.00	-7.87	AV	PASS
	V	5410	61.82	30.22	4.85	23.98	60.43	74.00	-13.57	PK	PASS
	V	5410	47.83	30.22	4.85	23.98	46.44	54.00	-7.56	AV	PASS

Remark:

1. Emission Level = Meter Reading + Antenna Factor + Cable Loss – Pre-amplifier, Margin= Emission Level - Limit
2. If peak below the average limit, the average emission was no test.
3. The amplitude of spurious emissions which are attenuated by more than 20dB below the permissible value has no need to be reported.
4. 802.11 a,802.11n20/40 of ANT have been tested,The worst mode is ANT 802.11a is recorded.





## 5. POWER SPECTRAL DENSITY TEST

### 5.1 APPLIED PROCEDURES / LIMIT

According to FCC §15.407(a), RSS-247 6.2.1.1

Power limits:

(1) For the band 5.15-5.25 GHz.

(i) For an outdoor access point operating in the band 5.15-5.25 GHz, the maximum power spectral density shall not exceed 17 dBm in any 1 megahertz band. If transmitting antennas of directional gain greater than 6 dBi are used, both the maximum conducted output power and the maximum power spectral density shall be reduced by the amount in dB that the directional gain of the antenna exceeds 6 dBi. The maximum e.i.r.p. at any elevation angle above 30 degrees as measured from the horizon must not exceed 125 mW (21 dBm).

(ii) For an indoor access point operating in the band 5.15-5.25 GHz, the maximum power spectral density shall not exceed 17 dBm in any 1 megahertz band. If transmitting antennas of directional gain greater than 6 dBi are used, both the maximum conducted output power and the maximum power spectral density shall be reduced by the amount in dB that the directional gain of the antenna exceeds 6 dBi.

(iii) For fixed point-to-point access points operating in the band 5.15-5.25 GHz, the maximum power spectral density shall not exceed 17 dBm in any 1 megahertz band. Fixed point-to-point U-NII devices may employ antennas with directional gain up to 23 dBi without any corresponding reduction in the maximum conducted output power or maximum power spectral density. For fixed point-to-point transmitters that employ a directional antenna gain greater than 23 dBi, a 1 dB reduction in maximum conducted output power and maximum power spectral density is required for each 1 dB of antenna gain in excess of 23 dBi. Fixed, point-to-point operations exclude the use of point-to-multipoint systems, omnidirectional applications, and multiple collocated transmitters transmitting the same information. The operator of the U-NII device, or if the equipment is professionally installed, the installer, is responsible for ensuring that systems employing high gain directional antennas are used exclusively for fixed, point-to-point operations.

(iv) For client devices in the 5.15-5.25 GHz band, the maximum power spectral density shall not exceed 11 dBm in any 1 megahertz band. If transmitting antennas of directional gain greater than 6 dBi are used, both the maximum conducted output power and the maximum power spectral density shall be reduced by the amount in dB that the directional gain of the antenna exceeds 6 dBi.

For OEM devices installed in vehicles, the maximum e.i.r.p. shall not exceed 30 mW or  $1.76 + 10 \log_{10} B$ , dBm, whichever is less. Devices shall implement transmitter power control (TPC) in order to have the capability to operate at least 3 dB below the maximum permitted e.i.r.p. of 30 mW. For other devices, the maximum e.i.r.p. shall not exceed 200 mW or  $10 + 10 \log_{10} B$ , dBm, whichever power is less. B is the 99% emission bandwidth in megahertz. The e.i.r.p. spectral density shall not exceed 10 dBm in any 1.0 MHz band.



### 5.2 TEST PROCEDURE

For devices operating in the bands 5.15-5.25 GHz, 5.25-5.35 GHz, and 5.47-5.725 GHz, the above procedures make use of 1 MHz RBW to satisfy directly the 1 MHz reference bandwidth specified in § 15.407(a)(5). For devices operating in the band 5.725-5.85 GHz, the rules specify a measurement bandwidth of 500 kHz. Many spectrum analyzers do not have 500 kHz RBW, thus a narrower RBW may need to be used. The rules permit the use of a RBWs less than 1 MHz, or 500 kHz, “provided that the measured power is integrated over the full reference bandwidth” to show the total power over the specified measurement bandwidth (i.e., 1 MHz, or 500 kHz). If measurements are performed using a reduced resolution bandwidth (< 1 MHz, or <500 kHz) and integrated over 1 MHz, or 500 KHz bandwidth, the following adjustments to the procedures apply:

- a) Set  $RBW \geq 1/T$ , where T is defined in section II.B.I.a).
- b) Set  $VBW \geq 3 RBW$ .
- c) If measurement bandwidth of Maximum PSD is specified in 500 kHz, add  $10\log(500\text{kHz}/RBW)$  to the measured result, whereas RBW (< 500 KHz) is the reduced resolution bandwidth of the spectrum analyzer set during measurement.
- d) If measurement bandwidth of Maximum PSD is specified in 1 MHz, add  $10\log(1\text{MHz}/RBW)$  to the measured result, whereas RBW (< 1 MHz) is the reduced resolution bandwidth of spectrum analyzer set during measurement.
- e) Care must be taken to ensure that the measurements are performed during a period of continuous transmission or are corrected upward for duty cycle.

Note: As a practical matter, it is recommended to use reduced RBW of 100 KHz for the sections 5.c) and 5.d) above, since RBW=100 KHZ is available on nearly all spectrum analyzers.

### 5.3 DEVIATION FROM STANDARD

No deviation.

### 5.4 TEST SETUP



### 5.5 EUT OPERATION CONDITIONS

The EUT tested system was configured as the statements of 2.1 Unless otherwise a special operating condition is specified in the follows during the testing.



5.6 TEST RESULTS

Temperature :	24.2°C	Relative Humidity:	53%
Pressure :	1010 hPa	Test Voltage :	DC 3.8V
Test Mode :	TX		
5.2G (5180-5240MHz):	Please refer to the Appendix A.5 for 5.2G WIFI RF Test Data.		
5.8G (5745-5825MHz):	Please refer to the Appendix B.5 for 5.8G WIFI RF Test Data.		



## 6. 26DB & 6DB &99% EMISSION BANDWIDTH

### 6.1 APPLIED PROCEDURES / LIMIT

The maximum power spectral density is measured as a conducted emission by direct connection of a calibrated test instrument to the equipment under test. If the device cannot be connected directly, alternative techniques acceptable to the Commission may be used. Measurements in the 5.725-5.85 GHz band, the minimum bandwidth 6 dB bandwidth of U-NII devices shall be at least 500KHz. Measurements in the 5.15-5.25 GHz, 5.25-5.35 GHz, and the 5.47-5.725 GHz bands are made over a bandwidth of 1 MHz or the 26 dB emission bandwidth of the device, whichever is less. A narrower resolution bandwidth can be used, provided that the measured power is integrated over the full reference bandwidth.

### 6.2 TEST PROCEDURE

- a) Set RBW = 100KHz.
- b) Set the VBW > RBW.
- c) Detector = Peak.
- d) Trace mode = max hold.
- e) Measure the maximum width of the emission that is constrained by the frequencies associated with the two outermost amplitude points (upper and lower frequencies) that are attenuated by 6 dB relative to the maximum level measured in the fundamental emission.

The following procedure shall be used for measuring (99 %) power bandwidth:

- 1. Set center frequency to the nominal EUT channel center frequency.
- 2. Set span = 1.5 times to 5.0 times the OBW.
- 3. Set RBW = 1 % to 5 % of the OBW
- 4. Set VBW  $\geq 3 \cdot$  RBW
- 5. Video averaging is not permitted. Where practical, a sample detection and single sweep mode shall be used. Otherwise, peak detection and max hold mode (until the trace stabilizes) shall be used.
- 6. Use the 99 % power bandwidth function of the instrument (if available).
- 7. If the instrument does not have a 99 % power bandwidth function, the trace data points are recovered and directly summed in power units. The recovered amplitude data points, beginning at the lowest frequency, are placed in a running sum until 0.5 % of the total is reached; that frequency is recorded as the lower frequency. The process is repeated until 99.5 % of the total is reached; that frequency is recorded as the upper frequency. The 99% occupied bandwidth is the difference between these two frequencies.





6.3 EUT OPERATION CONDITIONS

The EUT tested system was configured as the statements of 2.4 Unless otherwise a special operating condition is specified in the follows during the testing.

6.4 TEST RESULTS

Temperature :	24.2℃	Relative Humidity:	53%
Pressure :	1010 hPa	Test Voltage :	DC 3.8V
Test Mode :	TX		
-26dB Bandwidth	5.2G(5180-5240MHz):	Please refer to the Appendix A.3 for 5.2G WIFI RF Test Data.	
99% Bandwidth	5.2G(5180-5240MHz):	Please refer to the Appendix A.4 for 5.2G WIFI RF Test Data.	
-26dB Bandwidth	5.8G (5745-5825MHz):	Please refer to the Appendix B.3 for 5.8G WIFI RF Test Data.	
99% Bandwidth	5.8G (5745-5825MHz):	Please refer to the Appendix B.4 for 5.8G WIFI RF Test Data.	



7. MAXIMUM CONDUCTED OUTPUT POWER

7.1 APPLIED PROCEDURES / LIMIT

According to FCC §15.407,  
The maximum conducted output power should not exceed:

Frequency Band(MHz)	Limit
5150~5250	250mW
5725~5850	1W

RSS-247 6.2.1.1, RSS-247 6.2.4.1

Frequency Band(MHz)	Limit
5150~5250	200mW
5725~5850	1W

Frequency band 5150-5250 MHz

According to RSS-247 section 6.2.1.1: For OEM devices installed in vehicles, the maximum e.i.r.p. shall not exceed 30 mW or  $1.76 + 10 \log_{10} B$ , dBm, whichever is less. Devices shall implement transmitter power control (TPC) in order to have the capability to operate at least 3 dB below the maximum permitted e.i.r.p. of 30 mW.

For other devices, the maximum e.i.r.p. shall not exceed 200 mW or  $10 + 10 \log_{10} B$ , dBm, whichever power is less. B is the 99% emission bandwidth in megahertz. The e.i.r.p. spectral density shall not exceed 10 dBm in any 1.0 MHz band.

Frequency band 5250-5350 MHz

According to RSS-247 section 6.2.2.1: For OEM devices installed in vehicles, the maximum e.i.r.p. shall not exceed 30 mW or  $1.76 + 10 \log_{10} B$ , dBm, whichever is less. Devices shall implement TPC in order to have the capability to operate at least 3 dB below the maximum permitted e.i.r.p. of 30 mW.

Devices, other than devices installed in vehicles, shall comply with the following:

The maximum conducted output power shall not exceed 250 mW or  $11 + 10 \log_{10} B$ , dBm, whichever is less. The power spectral density shall not exceed 11 dBm in any 1.0 MHz band;

The maximum e.i.r.p. shall not exceed 1.0 W or  $17 + 10 \log_{10} B$ , dBm, whichever is less. B is the 99% emission bandwidth in megahertz. Note that devices with a maximum e.i.r.p. greater than 500 mW shall implement TPC in order to have the capability to operate at least 6 dB below the maximum permitted e.i.r.p. of 1 W.

Frequency bands 5470-5600 MHz and 5650-5725 MHz

According to RSS-247 section 6.2.3.1: The maximum conducted output power shall not exceed 250 mW or  $11 + 10 \log_{10} B$ , dBm, whichever is less. The power spectral density shall not exceed 11 dBm in any 1.0 MHz band.

The maximum e.i.r.p. shall not exceed 1.0 W or  $17 + 10 \log_{10} B$ , dBm, whichever is less. B is the 99% emission bandwidth in megahertz. Note that devices with a maximum e.i.r.p. greater than 500 mW shall implement TPC in order to have the capability to operate at least 6 dB below the maximum permitted e.i.r.p. of 1 W.

Frequency bands 5725-5850 MHz

The maximum conducted output power shall not exceed 1 W. The output power spectral density shall not exceed 30 dBm in any 500 kHz band. If transmitting antennas of directional gain greater than 6 dBi are used, both the maximum conducted output power and the output power spectral density shall be reduced by the amount in dB that the directional gain of the antenna exceeds 6 dBi. However, fixed point-to-point devices operating in this band may employ transmitting antennas with directional gain greater than 6 dBi without any corresponding reduction in transmitter conducted power. Fixed point-to-point operations exclude the use of point-to-multi point systems, omnidirectional applications and multiple collocated transmitters transmitting the same information.



## 7.2 TEST PROCEDURE

The EUT was directly connected to the Power meter

### 1. Device Configuration

If possible, configure or modify the operation of the EUT so that it transmits continuously at its maximum power control level (see section II.B.).

a) The intent is to test at 100 percent duty cycle; however a small reduction in duty cycle (to no lower than 98 percent) is permitted if required by the EUT for amplitude control purposes. Manufacturers are expected to provide software to the test lab to permit such continuous operation.

b) If continuous transmission (or at least 98 percent duty cycle) cannot be achieved due to hardware limitations (e.g., overheating), the EUT shall be operated at its maximum power control level with the transmit duration as long as possible and the duty cycle as high as possible.

### 2. Measurement using a Spectrum Analyzer or EMI Receiver (SA)

Measurement of maximum conducted output power using a spectrum analyzer requires integrating the spectrum across a frequency span that encompasses, at a minimum, either the EBW or the 99-percent occupied bandwidth of the signal.<sup>1</sup> However, the EBW must be used to determine bandwidth dependent limits on maximum conducted output power in accordance with § 15.407(a).

a) The test method shall be selected as follows: (i) Method SA-1 or SA-1 Alternative (averaging with the EUT transmitting at full power throughout each sweep) shall be applied if either of the following conditions can be satisfied:

- The EUT transmits continuously (or with a duty cycle  $\geq 98$  percent).
- Sweep triggering or gating can be implemented in a way that the device transmits at the maximum power control level throughout the duration of each of the instrument sweeps to be averaged. This condition can generally be achieved by triggering the instrument's sweep if the duration of the sweep (with the analyzer configured as in Method SA-1, below) is equal to or shorter than the duration T of each transmission from the EUT and if those transmissions exhibit full power throughout their durations.

(ii) Method SA-2 or SA-2 Alternative (averaging across on and off times of the EUT transmissions, followed by duty cycle correction) shall be applied if the conditions of (i) cannot be achieved and the transmissions exhibit a constant duty cycle during the measurement duration. Duty cycle will be considered to be constant if variations are less than  $\pm 2$  percent.

(iii) Method SA-3 (RMS detection with max hold) or SA-3 Alternative (reduced VBW with max hold) shall be applied if the conditions of (i) and (ii) cannot be achieved.

b) Method SA-1 (trace averaging with the EUT transmitting at full power throughout each sweep): (i) Set span to encompass the entire emission bandwidth (EBW) (or, alternatively, the entire 99% occupied bandwidth) of the signal.

(ii) Set RBW = 1 MHz.

(iii) Set VBW  $\geq 3$  MHz.

(iv) Number of points in sweep  $\geq 2$  Span / RBW. (This ensures that bin-to-bin spacing is  $\leq$  RBW/2, so that narrowband signals are not lost between frequency bins.)

(v) Sweep time = auto.

(vi) Detector = RMS (i.e., power averaging), if available. Otherwise, use sample detector mode.

(vii) If transmit duty cycle  $< 98$  percent, use a video trigger with the trigger level set to enable triggering only on full power pulses. Transmitter must operate at maximum power control level for the entire duration of every sweep. If the EUT transmits continuously (i.e., with no off intervals) or at duty cycle  $\geq 98$  percent, and if each transmission is entirely at the maximum power control level, then the trigger shall be set to "free run".

(viii) Trace average at least 100 traces in power averaging (i.e., RMS) mode.

(ix) Compute power by integrating the spectrum across the EBW (or, alternatively, the entire 99% occupied bandwidth) of the signal using the instrument's band power measurement function with band limits set equal to the EBW (or occupied bandwidth) band edges. If the instrument does not have a band power function, sum the spectrum

## 7.3 DEVIATION FROM STANDARD

No deviation.



7.4 TEST SETUP



7.5 EUT OPERATION CONDITIONS

The EUT tested system was configured as the statements of 2.4 Unless otherwise a special operating condition is specified in the follows during the testing.

7.6 TEST RESULTS

Temperature :	24.2°C	Relative Humidity:	53%
Pressure :	1010 hPa	Test Voltage :	DC 3.8V
Test Mode :	TX		
5.2G (5180-5240MHz):	Please refer to the Appendix A.2 for 5.2G WIFI RF Test Data.		
5.8G (5745-5825MHz):	Please refer to the Appendix B.2 for 5.8G WIFI RF Test Data.		



## 8.OUT OF BAND EMISSIONS

### 8.1 APPLICABLE STANDARD

According to FCC §15.407(b), RSS-247 6.2.1.2, RSS-247 6.2.4.2

Undesirable emission limits. Except as shown in paragraph (b)(7) of this section, the maximum emissions outside of the frequency bands of operation shall be attenuated in accordance with the following limits:

(1) For transmitters operating in the 5.15-5.25 GHz band: All emissions outside of the 5.15-5.35 GHz band shall not exceed an e.i.r.p. of  $-27$  dBm/MHz.

(2) Devices operating in the band 5725-5850 MHz shall have e.i.r.p. of unwanted emissions comply with the following:

- a) 27 dBm/MHz at frequencies from the band edges decreasing linearly to 15.6 dBm/MHz at 5 MHz above or below the band edges;
- b) 15.6 dBm/MHz at 5 MHz above or below the band edges decreasing linearly to 10 dBm/MHz at 25 MHz above or below the band edges;
- c) 10 dBm/MHz at 25 MHz above or below the band edges decreasing linearly to  $-27$  dBm/MHz at 75 MHz above or below the band edges; and
- d)  $-27$  dBm/MHz at frequencies more than 75 MHz above or below the band edges.

According to RSS-247 section 6.2.1.2: For transmitters with operating frequencies in the band 5150-5250 MHz, all emissions outside the band 5150-5350 MHz shall not exceed  $-27$  dBm/MHz e.i.r.p. Any unwanted emissions that fall into the band 5250-5350 MHz shall be attenuated below the channel power by at least 26 dB, when measured using a resolution bandwidth between 1 and 5% of the occupied bandwidth (i.e. 99% bandwidth), above 5250 MHz. The 26 dB bandwidth may fall into the 5250-5350 MHz band; however, if the occupied bandwidth also falls within the 5250-5350 MHz band, the transmission is considered as intentional and the devices shall comply with all requirements in the band 5250-5350 MHz including implementing dynamic frequency selection (DFS) and TPC, on the portion of the emission that resides in the 5250- 5350 MHz band.

## 8.2 TEST PROCEDURE

1. Check the calibration of the measuring instrument using either an internal calibrator or a known signal from an external generator.
2. Position the EUT without connection to measurement instrument. Turn on the EUT and connect its antenna terminal to measurement instrument via a low loss cable. Then set it to any one measured frequency within its operating range, and make sure the instrument is operated in its linear range.
3. Set RBW of spectrum analyzer to 1 MHz with a convenient frequency span.
4. Measure the highest amplitude appearing on spectral display and set it as a reference level. Plot the graph with marking the highest point and edge frequency.
5. Repeat above procedures until all measured frequencies were complete.

## 8.3 DEVIATION FROM STANDARD

No deviation.

## 8.4 TEST SETUP



## 8.5 EUT OPERATION CONDITIONS

The EUT tested system was configured as the statements of 2.4 Unless otherwise a special operating condition is specified in the follows during the testing.

## 8.6 TEST RESULTS

Temperature :	24.2°C	Relative Humidity:	53%
Pressure :	1010 hPa	Test Voltage :	DC 3.8V
Test Mode :	TX		
5.2G (5180-5240MHz):	Please refer to the Appendix A.6 for 5.2G WIFI RF Test Data.		
5.8G (5745-5825MHz):	Please refer to the Appendix B.6 for 5.8G WIFI RF Test Data.		



### 9.SPURIOUS RF CONDUCTED EMISSIONS

#### 9.1 CONFORMANCE LIMIT

Refer to 15.407(b):

Except as shown in paragraph 15.407(b)(7) of this section, the maximum emissions outside of the frequency bands of operation shall be attenuated in accordance with the following limits:

For transmitters operating in the 5.15-5.25 GHz band: All emissions outside of the 5.15-5.35 GHz band shall not exceed an e.i.r.p. of -27 dBm/MHz.

Refer to RSS-247/6.2.1.2:

For transmitters with operating frequencies in the band 5150-5250 MHz, all emissions outside the band 5150-5350 MHz shall not exceed -27 dBm/MHz e.i.r.p. Any unwanted emissions that fall into the band 5250-5350 MHz shall be attenuated below the channel power by at least 26 dB, when measured using a resolution bandwidth between 1 and 5% of the occupied bandwidth (i.e. 99% bandwidth), above 5250 MHz. The 26 dB bandwidth may fall into the 5250-5350 MHz band; however, if the occupied bandwidth also falls within the 5250-5350 MHz band, the transmission is considered as intentional and the devices shall comply with all requirements in the band 5250-5350 MHz including implementing dynamic frequency selection (DFS) and TPC, on the portion of the emission that resides in the 5250-5350 MHz band.

Devices operating in the band 5725-5850 MHz shall have e.i.r.p. of unwanted emissions comply with the following:

- a) 27 dBm/MHz at frequencies from the band edges decreasing linearly to 15.6 dBm/MHz at 5 MHz above or below the band edges;
- b) 15.6 dBm/MHz at 5 MHz above or below the band edges decreasing linearly to 10 dBm/MHz at 25 MHz above or below the band edges;
- c) 10 dBm/MHz at 25 MHz above or below the band edges decreasing linearly to -27 dBm/MHz at 75 MHz above or below the band edges; and
- d) -27 dBm/MHz at frequencies more than 75 MHz above or below the band edges.

#### 9.2 Measuring Instruments

The Measuring equipment is listed in the section 6.3 of this test report.

#### 9.3 TEST SETUP



#### 9.4 TEST PROCEDURE

The Spurious RF conducted emissions compliance of RF radiated emission should be measured by following the guidance in ANSI C63.10-2013 with respect to maximizing the emission by rotating the EUT, measuring the emission while the EUT is situated in three orthogonal planes (if appropriate), adjusting the measurement antenna height and polarization etc. Set RBW=100kHz and VBW= 300KHz to measure the peak field strength, and measure frequency range from 30MHz to 1GHz. Set RBW=1MHz and VBW= 3MHz to measure the peak field strength, and measure frequency range from 1GHz to 40GHz.



9.5 TEST RESULTS

Temperature :	24.2°C	Relative Humidity:	53%
Pressure :	1010 hPa	Test Voltage :	DC 3.8V
Test Mode :	TX		
5.2G (5180-5240MHz):	Please refer to the Appendix A.8 for 5.2G WIFI RF Test Data.		
5.8G (5745-5825MHz):	Please refer to the Appendix B.8 for 5.8G WIFI RF Test Data.		

Remark1: The measurement frequency range is from 30MHz to the 10th harmonic or 40G of the fundamental frequency. The lowest, middle and highest channels are tested to verify the spurious emissions and band edge measurement data.

Remark2: 27G to 40G is the background, so it does not show the data.



10.FREQUENCY STABILITY MEASUREMENT

10.1 LIMIT

Manufactures of U-NII devices are responsible for ensuring frequency stability such that an emission is maintained within the band of operation under all conditions of normal operation as specified in the user's manual.

The transmitter center frequency tolerance shall be ± 20 ppm maximum for the 5 GHz band (IEEE 802.11n specification).

10.2 TEST PROCEDURES

1. The transmitter output (antenna port) was connected to the spectrum analyzer.
2. EUT have transmitted absence of modulation signal and fixed channelize.
3. Set the spectrum analyzer span to view the entire absence of modulation emissions bandwidth.
4. Set RBW = 10 kHz, VBW = 30 kHz with peak detector and maxhold settings.
5. The test extreme voltage is to change the primary supply voltage from 85 to 115 percent of the nominal value
6. Extreme temperature is -20°C~70°C.

10.3 TEST SETUP LAYOUT



10.4 EUT OPERATION DURING TEST

The EUT was programmed to be in continuously un-modulation transmitting mode.

10.5 TEST RESULTS

Temperature :	24.2°C	Relative Humidity:	53%
Pressure :	1010 hPa	Test Voltage :	DC 3.8V
Test Mode :	TX		
5.2G (5180-5240MHz):	Please refer to the Appendix A.7 for 5.2G WIFI RF Test Data.		
5.8G (5745-5825MHz):	Please refer to the Appendix B.7 for 5.8G WIFI RF Test Data.		



Standard requirement:	FCC Part15 C Section 15.203, RSS-247 6.8
<p>15.203 requirement:</p> <p>An intentional radiator shall be designed to ensure that no antenna other than that furnished by the responsible party shall be used with the device. The use of a permanently attached antenna or of an antenna that uses a unique coupling to the intentional radiator, the manufacturer may design the unit so that a broken antenna can be replaced by the user, but the use of a standard antenna jack or electrical connector is prohibited.</p> <p>The applicant for equipment certification, as per RSP-100, must provide a list of all antenna types that may be used with the licence-exempt transmitter, indicating the maximum permissible antenna gain (in dBi) and the required impedance for each antenna. Licence-exempt transmitters that have received equipment certification may operate with different types of antennas. However, it is not permissible to exceed the maximum equivalent isotropically radiated power (EIRP) limits specified in the applicable standard (RSS) for the licence-exempt apparatus. Testing shall be performed using the highest gain antenna of each combination of licence-exempt transmitter and antenna type, with the transmitter output power set at the maximum level.<sup>9</sup> When a measurement at the antenna connector is used to determine RF output power, the effective gain of the device's antenna shall be stated, based on a measurement or on data from the antenna manufacturer.</p>	
EUT Antenna:	
The antenna is FPC Antenna, the best case gain of the antenna is 5.2GWIFI: 3.19dBi, 5.8GWIFI: 3.44dBi, reference to the appendix II for details	



Reference to the appendix I for details.

12. EUT CONSTRUCTIONAL DETAILS

Reference to the appendix II for details.

\*\*\*\*\* END OF REPORT \*\*\*\*\*