

MUNBYN

Version 1.00

Thermal Label Printer

User Manual



Unleash Business Creativity

RealWriter 402 Bluetooth

Contents

1.0. Product Introduction	1
1.1. What's in the Box?	1
1.2. Printer Features	2
2.0. Set Up the Printer	3
2.1. Quick Printer Connection	3
2.2. Label Setup	4
3.0. Bluetooth Connection	5
3.1. Mobile Phone Printing	5
3.1.1 Download the App	5
3.1.2 Select the Printer	5
3.1.3 Open Permission	6
3.1.4 Connect the Printer	7
3.1.5 First Print	8
3.2. Windows Bluetooth Printing	11
4.0. USB Connection for Laptop/PC	15
4.1. Mac Driver Installation	15
4.2. Windows Driver Installation	17
5.0. Pro Tips	21
6.0. FAQ	22
6.1. How to maintain the print head?	22
6.2. Why is the printed label not clear?	23
7.0. LED Status	24
8.0. Feeder Button Instruction	24
9.0. Specifications	25
10.0. Safety Notices	26

11.0. FCC Statement	-----	27
12.0. Tech Support	-----	28



Deutsches Benutzerhandbuch /
Manual de usuario en español
Manuel d'utilisation en français /
日本語のユーザーマニュアル

1.0. Product Introduction

1.1. What's in the Box?



A Printer

B Power Cord

C Type-C Cable

D Type-C to USB Adapter

E Power Adapter

F User Manual

G Quick Tips

H Labels×10

● If contents are missing or damaged, please contact us.

1.2. Printer Features

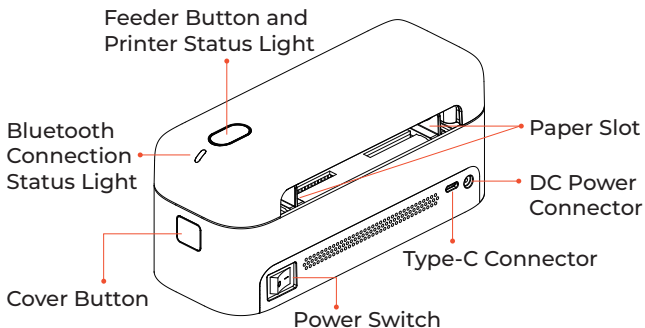

Tips	
Cover Button	Press the buttons to open the printer cover
Feed Button & Status Light	Feed button function refer to page 24 Status light refer to page 24
Bluetooth Connection Status Light	Bluetooth Connection Status Light refer to page 24
DC Power Connector	Please use the original power adapter to connect the DC power connector and the external power supply.
Type-C Connector	Please use the original Type-C cable to connect the Type-C connector and computer. If you are using a Windows with only USB port, please use the USB adapter to connect the original Type-C cable.
Power Switch	Please keep it off before connecting the power supply
Paper Slot	Once the paper is placed, adjust the slot to securely hold the paper in place.

2.0.Set Up the Printer

Scan the QR code on the right for more video tutorials:

munbyn.biz/402bvideo



More Setup Videos

2.1. Quick Printer Connection



1. Ensure the printer is power off



2. Connect the power adapter to the printer



3. Connect the power cord and plug in the power supply



4. Connect the Type-C cable to the printer



5. Connect the Type-C cable to the computer



6. Turn the printer on

● Please follow the sequence of the above picture to operate.

2.2. Label Setup

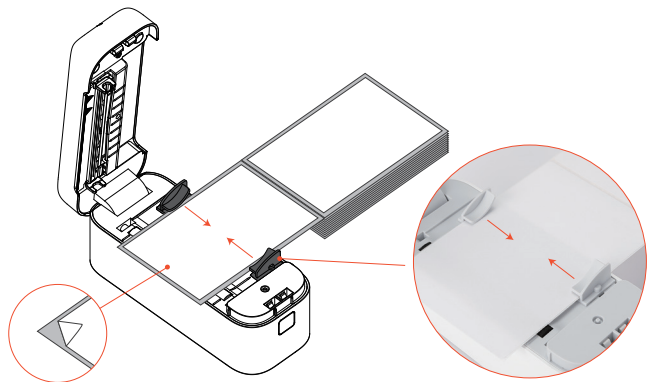

Automatic label identification:

Load no less than 4 consecutive labels into the printer. Once the cover is closed, the machine will automatically attempt to feed the paper.

If it fails to do so, please manually calibrate the paper: press and hold the feeder button until you hear a "beep". The printer will then perform label identification and calibration.

3.0. Bluetooth Connection

The printer is compatible with Bluetooth phones, tablets, and Windows computers, **but not with Mac computers over Bluetooth**. The printer cannot be directly connected to mobile phones or tablet devices via Bluetooth, and it requires the "**Munbyn Print**" App for connection.

3.1. Mobile Phone Printing

3.1.1 Download the App

Search "**Munbyn Print**" on **App Store** or **Google Play** to get the App or scan the QR code below to download.



Munbyn Print

3.1.2 Select the Printer

Open the MUNBYN APP, find and tap "RW402B", and click "OK" as shown in the picture:



3.1.3 Open Permission

The app requires local file access and Bluetooth function to run properly. Please follow the guide to grant the necessary permissions to the app.

Note: It is Google's rule. Our App needs to abide by this rule on the Google platform. But please rest assured that we will firmly protect user privacy.

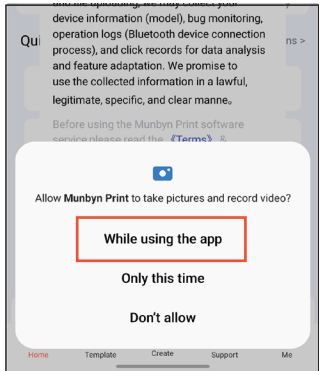
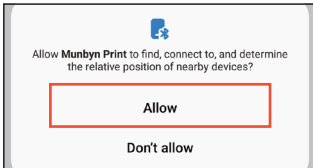
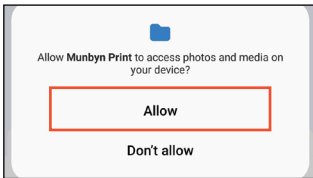

3.1.4 Connect the Printer

(1) Click the icon in the upper left corner to reconnect the printer.

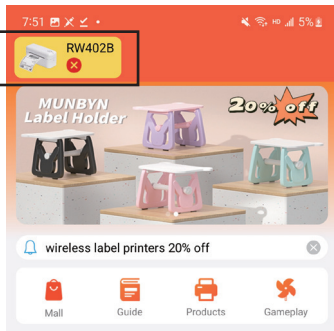

(2) After the software searches for the device, select the Bluetooth device. A pop-up window indicating a successful connection will appear in the App after successfully connecting the printer, as shown in the figure below.

Note: At this time, the Bluetooth status light on the printer will turn blue.

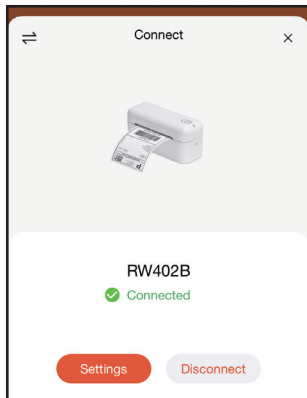
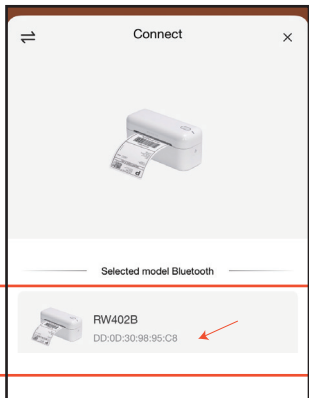

3.1.5 First Print

Note: Before starting to print, please ensure that the printer is successfully connected, as shown in Figure-1. If an error state occurs, as shown in Figure-2, check whether the printer is turned on and refer to Section 3.1.2 for instructions on clicking the icon in the upper left corner to reconnect the printer.

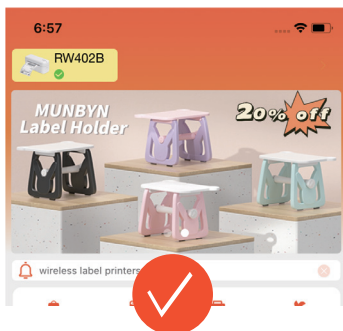

Figure-1

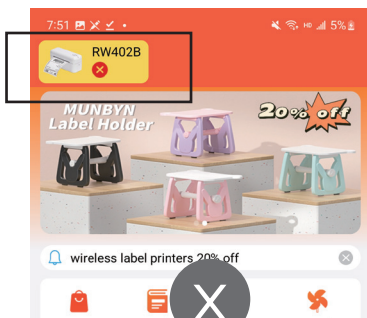
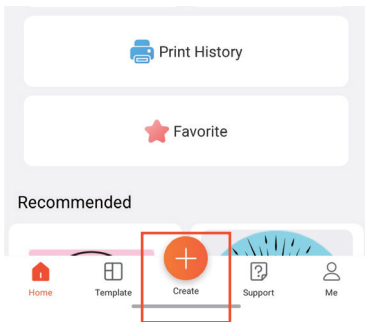

Figure-2

After the device is successfully connected, we start creating and printing:

1) Click Create on the Home page.



2) Check whether the size set by the App matches the actual size of the label paper.

Note: The size of the label that comes with the labels 4×6 inches, if you use other labels, please pay attention to their size.

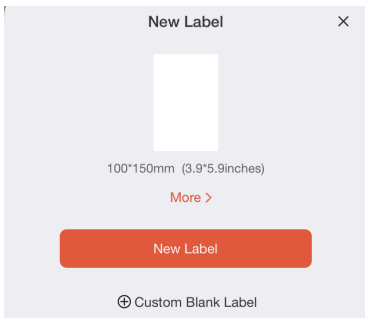

3) Design label

Note: The template is created successfully, and the design is carried out within the template area, and the content beyond the area will not be printed.

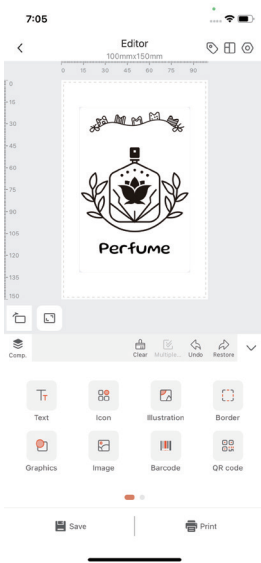

4) Print label

Click "Print" to check that the label preview matches the preset. Set the print density and number and tap "Print".

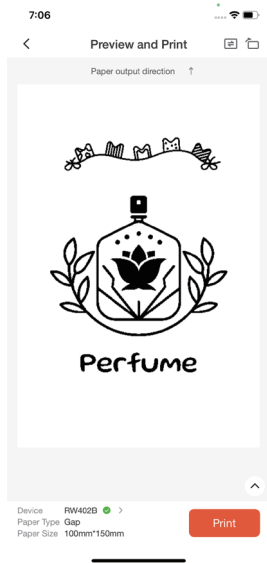

Please scan the QR code below to watch how to use the Munbyn App to connect and print.

Demo video: munbyn.biz/402bvideo

3.2. Windows Bluetooth Printing

Scan the QR code on the right for the video tutorial:

munbyn.biz/402bwindbc



Note:

(1) The Bluetooth connection on a PC is compatible only with the Windows operating system.

(2) Please ensure that all letters in the link are entered in lowercase. Otherwise, you will not be able to access the corresponding webpage.

Please follow the steps below:

1) Turn on Bluetooth to the Windows device.

2) Install the driver. Here are two methods to download the driver:

① You can get the driver by accessing this link:

munbyn.biz/402bwind

② Connect the printer to your computer using a USB cable. Once connected, access the removable drive that appears on your computer. Locate the driver installation file within this drive, open it, and select the appropriate driver for your operating system to download and install.

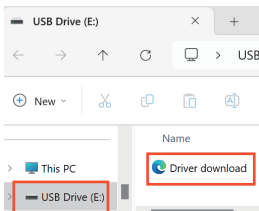

Download macOS driver with the model RW402B printer

Download Windows driver with the model RW402B printer

View the document with the model RW402B printer

3) Run the installer you downloaded. When prompted, choose the language you want to use for the installation.

Note: When installing the Windows driver, a security warning alert may pop up. Please click the "More Info" -> "Run away" button to agree to run the installation.

4) Select the "**Bluetooth**" connection method, and click "**Next**".

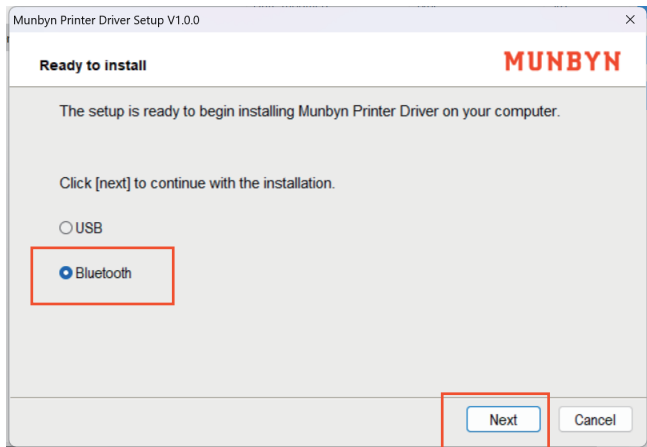

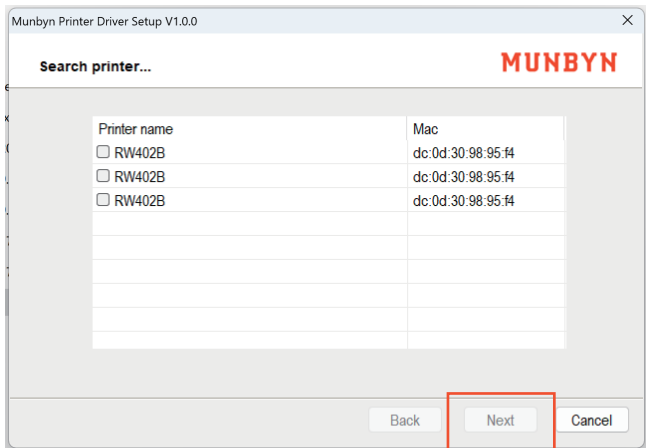

5) Select the connection printer, and click "Next" to complete the installation.

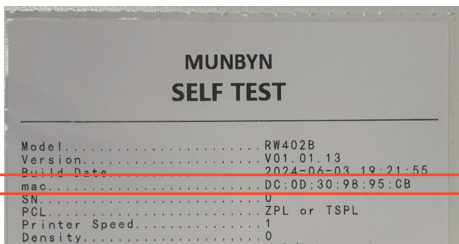

Note: If you have multiple devices, please double-click the Feeder Button to print a self-test page and check the "mac" address to connect to your designated device.



6) Open the file to be printed, click the Print button, and select Munbyn RW402B on the Print preview page.

Print	1 sheet of paper
Destination	 Munbyn RW402B ▼
Pages	All ▼
Copies	1
Paper size	4.00" x 6.00" (101.6 x 152.4mm) ▼
Pages per sheet	1 ▼
Scale	Fit to paper ▼
Print using system dialog... (Ctrl+Shift+P) 	

4.0.USB Connection for Laptop/PC

4.1. Mac Driver Installation for USB Cable

Scan the QR code on the right for the video tutorial:munbyn.biz/402bmacv



Note:

Please ensure that all letters in the link are entered in **lowercase**. Otherwise, you will not be able to access the corresponding webpage.

1)Connect the printer to the computer using a USB cable, then open the power switch to turn on the printer. (If you have already completed this step, please proceed directly to Step 2.)

2)Once connected, access the removable drive that appears on your computer. Locate the driver installation file within this drive, open it, and select the appropriate driver for your operating system to download and install.

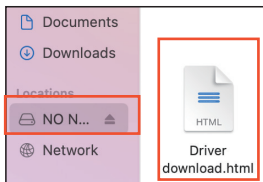

Download macOS driver with the model RW402B printer

Download Windows driver with the model RW402B printer

View the document with the model RW402B printer

Tips:

You can also get the driver by accessing this link:
munbyn.biz/402bmacd

3) Please double-click on the pkg installer to begin. Follow the installation steps until you receive the "Installation was successful" message shown below.

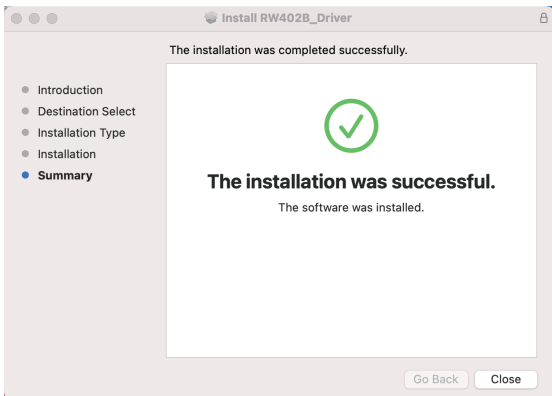
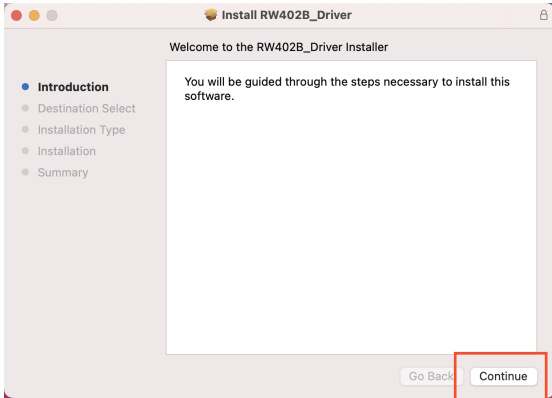

Finally, enter the link below to open the shipping label template and test whether the printer can print normally.
munbyn.biz/sample46

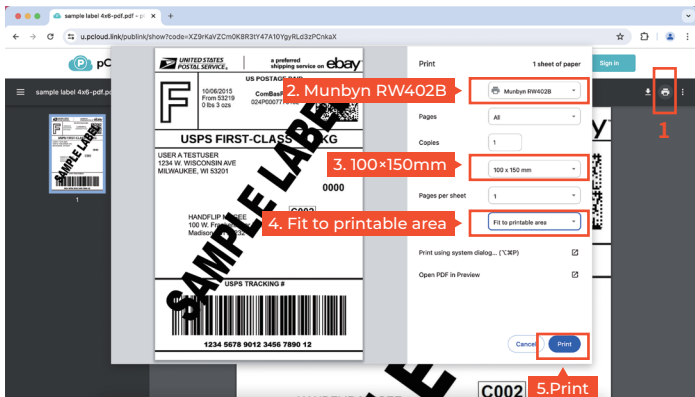

4.2. Windows Driver Installation for USB Cable

Scan the QR code on the right for the video tutorial:
munbyn.biz/402bwindv

Note: Please ensure that all letters in the link are entered in **lowercase**. Otherwise, you will not be able to access the corresponding webpage.



1) Connect the printer to the computer using a USB cable, then open the power switch to turn on the printer. (If you have already completed this step, please proceed directly to Step 2.)

2) Once connected, access the removable drive that

appears on your computer. Locate the driver installation file within this drive, open it, and select the appropriate driver for your operating system to download and install.

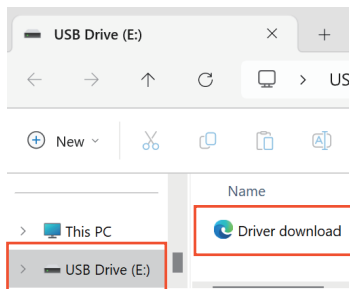

Download macOS driver with the model RW402B printer

Download Windows driver with the model RW402B printer

View the document with the model RW402B printer

Tips: You can also get the driver by accessing this link:
munbyn.biz/402bwind

3)Run the installer you downloaded. When prompted, choose the language you want to use for the installation.

Note: When installing the Windows driver, a security warning alert may pop up. Please click the "More Info" -> "Run away" button to agree to run the installation.

4) Click **"USB"** -> **"Next"** -> **"Finish"** to complete the installation.

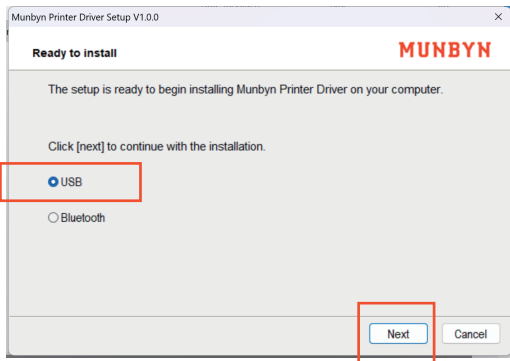

5) Follow the installation prompts until you click **"Finish"** to complete the setup and exit the installer. After the driver installation is complete, the printer will appear in your printer list.

You can follow the steps below to view:

Go to **Settings** -> **Bluetooth & devices** -> **Printers & scanners**.

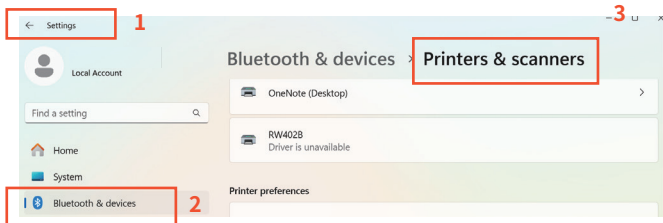

6) Finally, enter the link below to open the shipping label template and test whether the printer can print normally.
munbyn.biz/sample46



Note: If the USB port fails to recognize the printer, please follow these steps:

- Unplug the USB cable from both the computer and the printer, then reinsert it, ensuring the cable is securely connected.
- Restart the printer by shutting it down and then turning it back on.

5.0.Pro Tips

- **Anytime you change your label**, run the automatic label identification.
- Press the feeder button on the printer to **skip a blank label**.
- **To run a self-test**, double-click the feeder button.
- **Avoid poor quality labels** as they can damage the printer.
- Regularly **clean the printer head**.
- **If the paper is jammed and the red light flashes**, please first clear the jammed paper before running the Automatic label identification.
- Insert Munbyn into the **same USB port** on your computer every time. This will avoid creating duplicate copies of the printer in your operating system.

6.0.FAQ

FAQ file, please visit: munbyn.biz/402bfaq



6.1. How to maintain the print head?

When we use the device to print more than 1000 labels, we need to clean the print head. Here is the video to maintain the print head: munbyn.biz/402bclean

Here are the steps that maintain the print head:

1. Please turn printer off and allow it to cool down (about half a minute)
2. Please use alcohol wipes or wipes to clean the print head marked at the following picture.



3. Please wait 2-5 minutes until the print head dry, then turn the printer on.
4. Please use high-quality thermal label paper (such as Munbyn label paper) as much as possible to prevent the inferior label paper from peeling off and remaining on the print head, which will affect the life of the print head.

6.2. Why is the printed label not clear?

(1) Try to choose PDF file format for printing instead of PNG, JPG, and other image formats, when the barcode you print out is light (please refer to the picture)









(2) In the print preview interface, switch the print quality option from 'Normal' to 'Best'.

(3) If it is still not clear for the label, you can wipe the print head with alcohol wipes or wet tissues.

For more questions, please visit: munbyn.biz/helpcenter

7.0.LED Status

LED Status	Light	Description	Troubleshoot
	Green Light (always on)	Normal operation	/
	Blue Light (always on)	Bluetooth connected	/
	Red Light (always on)	Label paper is not identified	Organize the papers, then press and hold on the feeder button for one beep to run label identification
	Red Light (always on)	Cover is not closed	Check that the cover is completely closed
	Flashing Green and Red	Printer head is overheated	Printer will automatically resume once the printer head has cooled down
	Orange	Firmware upgrade in progress	/

8.0.Feeder Button Instruction

Printer status	Feeder button	Function
Standby	Single Click	Feed Paper
Standby	Double Click	Print Self-test
Standby	Press and hold on until you hear one beep	Automatic label identification
Standby	Press and hold on until you hear three beeps (for 6 second)	Reset Printer

9.0.Specifications

Method	Direct Thermal
Resolution	203 dpi
Max Printing Speed	150 mm/s
Paper Width	40 -110 mm (1.57-4.3 inches)
Paper Thickness	0.06 - 0.25 mm
Power Adapter	24V / 2.5A
Printing Life	TPH 50 KM
Operating Environment	Temperature: 0 to 45°C Humidity: 10-90% (non-condensing)
Storage Environment	Temperature: -10 to 50°C Humidity: 10-80% (non-condensing)
Connection	Bluetooth / USB
Weight	1.7 kg / 3.75 lbs
Dimensions	200×80×90mm (L *W *H)

10.0. Safety Notices

- The printer head can become very hot after printing labels. Do not touch the printer head.
- Do not bend the power cord excessively or place objects on the cord.
- Do not use the printer if you find any irregularities as these could result in fire or electrocution.
- Keep the printer out of reach of children.
- Use only approved accessories and do not try to disassemble, repair the unit by yourself.
- Keep the printer away from water and other objects that could penetrate the components.
- Please unplug the printer when it is not in use for long periods.
- If you have problems connecting to the printer with the Munbyn Print App, you can try to restart the App or reinstall the App. If your problem is still not resolved, please contact us.

11.0. FCC Statement

Changes or modifications not expressly approved by the party responsible for compliance could void the user's authority to operate the equipment.

This equipment has been tested and found to comply with the limits for a Class B digital device, pursuant to Part 15 of the FCC Rules. These limits are designed to provide reasonable protection against harmful interference in a residential installation. This equipment generates uses and can radiate radio frequency energy and, if not installed and used in accordance with the instructions, may cause harmful interference to radio communications.

However, there is no guarantee that interference will not occur in a particular installation. If this equipment does cause harmful interference to radio or television reception, which can be determined by turning the equipment off and on, the user is encouraged to try to correct the interference by one or more of the following measures:

- Reorient or relocate the receiving antenna.
- Increase the separation between the equipment and receiver.
- Connect the equipment into an outlet on a circuit different from that to which the receiver is connected.
- Consult the dealer or an experienced radio/TV technician for help.

This equipment complies with FCC radiation exposure limits set forth for an uncontrolled environment. This equipment should be installed and operated with a minimum distance of 20 cm between the radiator & your body.

12.0. Tech Support

E-Mail:

support@munbyn.com

WhatsApp:

+86 13352950490

Phone:

+1 650 206 2250

Skype:

munbyn

Support time:

Monday to Friday 24 hours



MUNBYN provides 24 months warranty and lifetime free service.

If you encounter any issues with the product, please contact the MUNBYN team to promptly receive troubleshooting tips or a replacement.

You can access the link below or scan the QR code to download user manuals in other languages.



Other Languages:

munbyn.biz/402bminorlang

Deutsches Benutzerhandbuch
Manual de usuario en español
Manuel d'utilisation en français
日本語のユーザーマニュアル

Model: RW402B

- English: "

This device complies with Industry Canada licence-exempt RSS standard(s). Operation is subject to the following two conditions:

(1) this device may not cause interference, and

(2) this device must accept any interference, including interference that may cause undesired operation of the device."

- French:"

Le présent appareil est conforme aux CNR d'Industrie Canada applicables aux appareils radio exempts de licence. L'exploitation est autorisée aux deux conditions suivantes :

(1) l'appareil n' doit pas produire de brouillage, et

(2) l'utilisateur de l'appareil doit accepter tout brouillage radioélectrique subi, même si le brouillage est susceptible d'en compromettre le fonctionnement."

MUNBYN

Unleash Business Creativity