

acknowledgement

SPECIFICATION FOR

客户:

CUSTOMER: Anrui micro

客户料号:

CUST P/N:

天夏料号:

TX P/N:

TX -D 42.8*5.3*0.6-6.5UH

产品型号:

DESC:

20.5*39.5-0.08*48P -10TS -18mm -

D 42.8 * 5.3 * 0.6 Double slot outlet with backing tape-6.5 uh

日期

DATE:

2024/03/07

版本:

Version:

A .0

拟制 PREPARED BY	审核 CHECKED BY	批准 APPROVED BY	客户承认 CUSTOMER AP PROVE
Luo Xiongbin	Yan Zhang	Luo Yongjun	

Shenzhen Tianxia Technology Co.,
LTD

地址: Room 523-525, C 33 Science and Technology
Innovation Park, District 33, Bao'an District,
Shenzhen City

电话: 18718699959

S PECIFICATION

产品型 号: D E SC	20.5*39.5-0.08 * 48P-10TS-18mm- D 42.8 * 5.3 * 0.6 Double channel outlet tape back glue- 6.5 uh	Rev : A.0	客户 CUST: Customer material number CUST P / N:	
---------------------	--	--------------	---	--

1. Dimension DIMENSION: (mm)

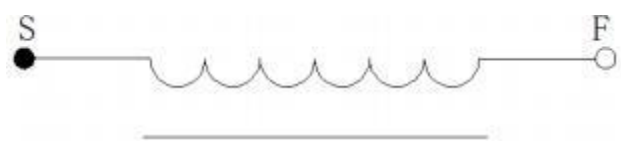
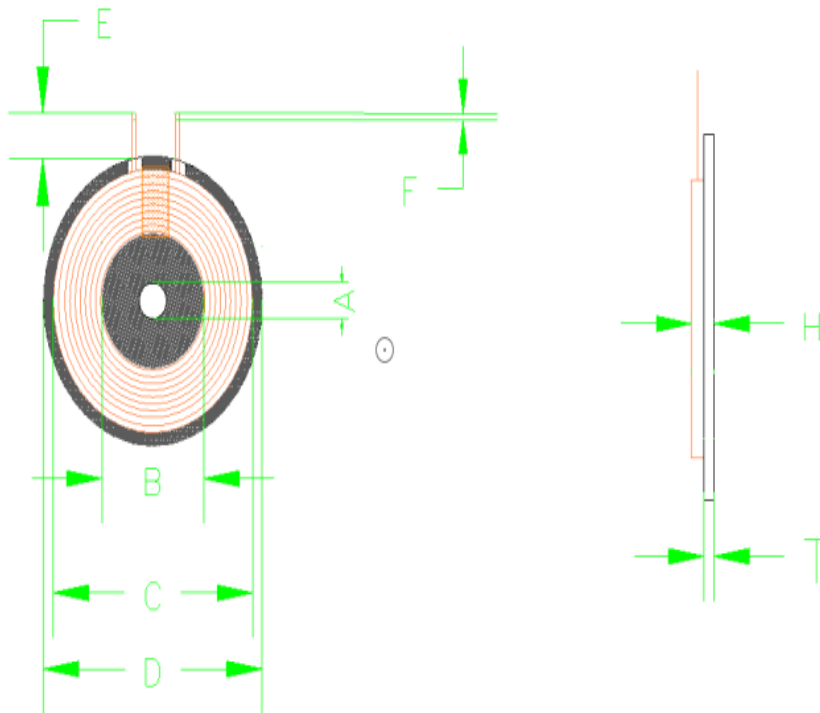

A The inner hole of the magnetic plate	$5.3 \pm 0.3\text{mm}$
B coil inner diameter	$20.5 \pm 0.5\text{mm}$
C The coiled-coil outer diameter	$37.5 \pm 1\text{mm}$
D Magnetic sheet outer diameter	$42.5 \pm 0.5\text{mm}$
E length of lead	$18 \pm 2\text{mm}$
The length of the F dip tin	5mmMAX
T-sheet thickness	$0.6 \pm 0.1\text{mm}$
H aggregate thickness (excluding lead lines)	1.6mmMAX

Note: 1. Coils cross out of the line, do not loosen the line. 2 Stick with a D 42.8*5.3*0.6mm ferrite hard magnetic sheet 3. Overall thickness of the coil Degree 1.6mmMAX (without the lead); 5. Ring the white transparent insulating rubber around the outlet end

3. Winding parameter Winding Specification:

序号 NO.	端子 TERMINAL	线径 WIRE	圈数 Turns	绕线方向 Winding Direction
1	L S F	0.08*24PX2	10Ts	anticlockwise

4. Electrical characteristics ELECTRICAL CHARACTERISTICS:
 Temperature TEMPERATURE: 25 ± 10°C, humidity RELATIVE HUMIDITY: 65 ± 20%
 orde

Order number NO.	The Project ITEM	Terminal, TERMINAL	standard SPECIFICATION	test condition TEST FREQUENCY	measuring and test instruments TEST EQUIPMENTS
1	IND.	S-F	4.0 uH ± 20%, individual coil	100KHz/1.0V	LCZ METER 1062B
2	IND.	S-F	6.5 uH ± 10% tape magnetic chip	100KHz/1.0V	LCZ METER 1062B

拟制 / 日期 PREPARED BY / DATE	审核 / 日期 CHECKED BY DATE
Luo Xiongbin 2024 / 03 / 07	Zhang Yan 2024 / 03 / 07