

# FCC TEST REPORT

**Report No.** ..... NTC-ER2403025

**Applicant's name** ..... Bridgelux, Inc.

**Address** ..... 46410 Fremont Boulevard, Fremont, CA 94538 USA

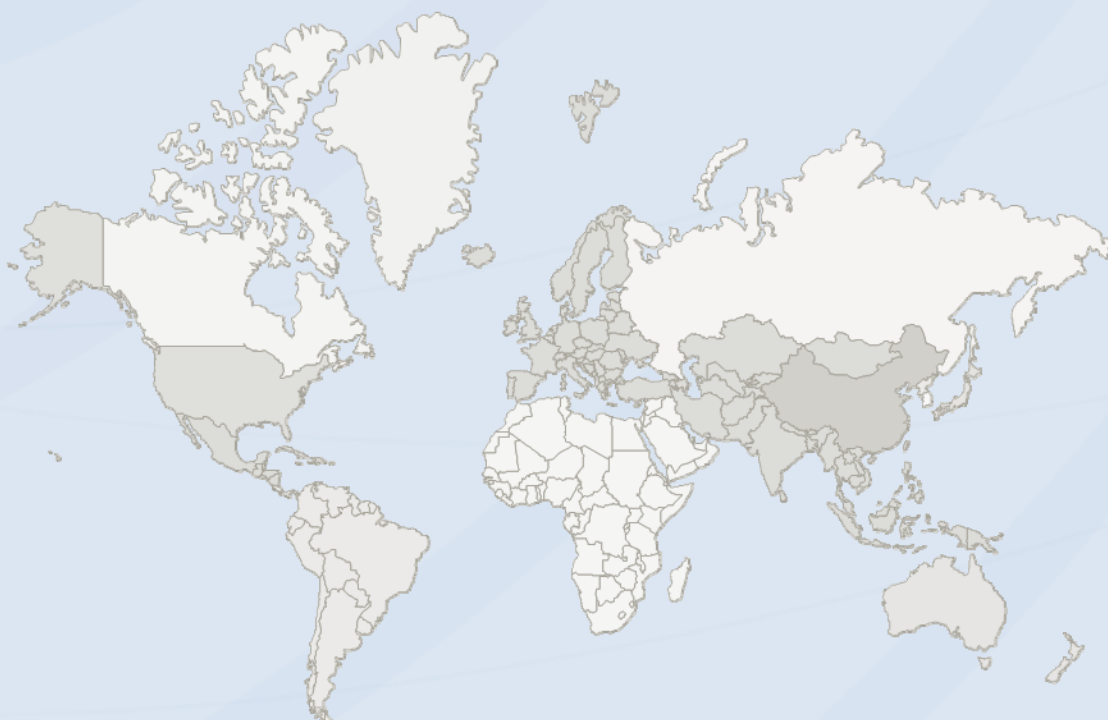

## **DONGGUAN NEW TESTING CENTRE CO., LTD**

Ⓒ Address: 31F & 3F, No. 1 the 1st North Industry Road Songshan Lake Science & Technology Park Dongguan, People's Republic of China 523808

☎ Tel: +86-769-22212079

🌐 Web: <http://www.ntc-cert.com>

✉ E-mail: [dave@ntc-cert.com](mailto:dave@ntc-cert.com)

## TABLE OF CONTENTS

<b>TEST REPORT DECLARE .....</b>	<b>3</b>
1. Summary of test results .....	4
2. General test information .....	4
2.1. Detail models .....	5
2.2. Test Peripheral List.....	6
2.3. Block diagram EUT configuration for test.....	6
2.4. Test environment conditions .....	6
2.5. Measurement uncertainty .....	6
3. Power Line Conducted Emission Test.....	7
3.1. Test equipment .....	7
3.2. Block diagram of test setup .....	7
3.3. Power Line Conducted Emission Limits (Class B) .....	7
3.4. Test Procedure.....	8
3.5. Test Result.....	8
4. Radiated emission test.....	11
4.1. Test equipment .....	11
4.2. Block diagram of test setup .....	12
4.3. Limit.....	14
4.4. Test Procedure.....	15
4.5. Test result .....	15
5. Output Power.....	24
5.1. Test equipment .....	24
5.2. Block diagram of test setup .....	24
5.3. Limit.....	24
5.4. Test Procedure.....	24
5.5. Test result .....	25
6. -6dB Bandwidth.....	31
6.1. Test equipment .....	31
6.2. Block diagram of test setup .....	31
6.3. Limit.....	31
6.4. Test Procedure.....	31
6.5. Test result .....	32
7. Band Edges Measurement.....	38
7.1. Test equipment .....	38
7.2. Block diagram of test setup .....	38
7.3. Limit.....	38

7.4. Test Procedure.....	38
7.5. Test result .....	39
8. Conducted Spurious Emission.....	45
8.1. Test equipment .....	45
8.2. Block diagram of test setup.....	45
8.3. Limit.....	45
8.4. Test Procedure.....	45
8.5. Test result .....	46
9. Conducted Output Power Spectral Density .....	55
9.1. Test equipment .....	55
9.2. Block diagram of test setup .....	55
9.3. Limit.....	55
9.4. Test Procedure.....	55
9.5. Test result .....	56
10. Antenna Requirement .....	62
10.1. Standard requirement .....	62
10.2. EUT Antenna .....	62
11. Test setup photograph .....	63
11.1. Photos of power line conducted emission test.....	63
11.2. Photos of radiated emission test .....	63
12. Photos of the EUT .....	65

## TEST REPORT DECLARE

<b>FCC ID</b>	:	2BF24-20BS-U405W
<b>Equipment under Test</b>	:	LED Driver
<b>Model /Type</b>	:	BXDR-PS-20BS-U405W-01-A
<b>Listed Models</b>	:	N/A
<b>Trade Mark</b>	:	Bridgelux
<b>Applicant</b>	:	Bridgelux, Inc.
<b>Address</b>	:	46410 Fremont Boulevard, Fremont, CA 94538 USA
<b>Manufacturer</b>	:	Bridgelux, Inc.
<b>Address</b>	:	46410 Fremont Boulevard, Fremont, CA 94538 USA
<b>Test Laboratory</b>	:	Dongguan New Testing Centre Co., Ltd
<b>Address</b>	:	1F & 3F, No. 1 the 1st North Industry Road Songshan Lake Science & Technology Park Dongguan, People' s Republic of China 523808

**Test Standard Used:**

FCC Rules and Regulations Part 15 Subpart C: 15.247, ANSI C63.10:2020.

**We Declare:**

The equipment described above is tested by Dongguan New Testing Centre Co., Ltd and in the configuration tested the equipment complied with the standards specified above. The test results are contained in this test report and Dongguan New Testing Centre Co., Ltd is assumed of full responsibility for the accuracy and completeness of these tests.

**After test and evaluation, our opinion is that the equipment provided for test compliance with the requirement of the above FCC standards.**

<b>Report No.:</b>	NTC-ER2403025		
<b>Date of Test:</b>	Mar. 21, 2024 to Apr.10, 2024	<b>Date of Report.:</b>	Apr. 12, 2024

**Prepared By:**



**Jack Liu/Engineer**



**Dave Gao/LAB Manager**

Note: This report applies to above tested sample only. This report shall not be reproduced in parts without written approval of Dongguan New Testing Centre Co., Ltd

## 1. Summary of test results

Description of Test Item	Standard	Results
Antenna Requirement	Section 15.247(c)	PASS
Conduction Emissions	Section 15.207(a)	PASS
Radiated Emissions	Section 15.247(d)	PASS
Carrier Frequencies Separated	Section 15.247(a)(1)	PASS
Dwell Time	Section 15.247(a)(1) (iii)	PASS
Maximum Peak Output Power	Section 15.247(b)	PASS
Band edge	Section 15.247(d)	PASS
Conducted Spurious Emissions	Section 15.247(d)	PASS

## 2. General test information

Description of EUT

EUT* Name	: LED Driver
Test model	: BXDR-PS-20BS-U405W-01-A
EUT function description	: Please reference user manual of this device
Power supply	: 120-277V, 50/60Hz 0.25A 24W
Operation frequency:	: 2412 MHz to 2462 MHz for 802.11b/g/n(HT20)
Number of Channels:	: 11 Channels for 802.11b/g/n(HT20)
Modulation Technology:	: 802.11b: CCK/QPSK/BPSK 802.11g/n: BPSK/QPSK/16QAM/64QAM
Transmit Data Rate:	: 802.11b :1/2/5.5/11 Mbps 802.11g :6/9/12/18/24/36/48/54 Mbps 802.11n(HT20): 7.2/14.4/21.7/28.9/43.3/57.8/65/72.2 Mbps
Channel Separation:	: 5 MHz
Antenna Type	: Ceramic Antenna
Gain:	: Max 0dBi
Hardware Version:	: V1.0
Software Version:	: V1.0

Note: 1, EUT is the ab. of equipment under test.

Frequency list:

1. Test frequencies are lowest channel: 2412 MHz, middle channel: 2437 MHz and highest channel: 2462 MHz for 802.11b/g/n(HT20)

Channel	Frequency (MHz)	Channel	Frequency (MHz)
1	2412	7	2442
2	2417	8	2447
3	2422	9	2452
4	2427	10	2457
5	2432	11	2462
6	2437		

Description of test modes

No.	TEST Mode DESCRIPTION
1	Low channel TX
2	Middle channel TX
3	High channel TX
4	Keeping TX mode
Note: Transmit by 802.11b with Data rate (1/2/5.5/11) Transmit by 802.11g with Data rate (6/9/12/18/24/36/48/54) Transmit by 802.11n (20MHz) with Data rate (6.5/13/19.5/26/39/52/58.5/65)	

Note:

1. The EUT has been set to operate continuously on the lowest, middle and highest operation frequency Individually, and the EUT is operating at its maximum duty cycle > or equal 98%
2. All modes under which configure applicable have been tested and the worst mode test data recording in the test report, if no other mode data.
3. For Radiated Emission, 3 axis were chosen for testing for each applicable mode.

2.1. Detail models

Model	Rating	Note
BXDR-PS-20BS-U405W-01-A	120-277V, 50/60Hz 0.25A 24W	N/A

Note: All the same except model name.

## 2.2. Test Peripheral List

No.	Equipment	Manufacturer	Model No.	Serial No.	Note
1	Notebook	Lenovo	ThinkPadE450	PF-0LRXDH	--

## 2.3. Block diagram EUT configuration for test

For EUT Tx mode:

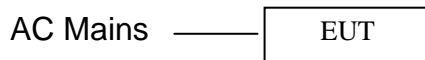

## 2.4. Test environment conditions

During the measurement the environmental conditions were within the listed ranges:

Temperature range:	21-24°C
Humidity range:	40-75%
Pressure range:	86-106kPa

## 2.5. Measurement uncertainty

Test Item	Uncertainty
Uncertainty for Conduction emission test	3.20 dB
Uncertainty for Radiation Emission test (30MHz – 1GHz)	4.60 dB (Polarize: V)
	4.60 dB (Polarize: H)
Uncertainty for Radiation Emission test (1GHz – 18GHz)	4.82 dB (Polarize: V)
	4.52 dB (Polarize: H)
Bandwidth	±1.2%
Stop Transmitting Time Test	±0.5%
Uncertainty for frequency error	5.8 x 10-8

Note: This uncertainty represents an expanded uncertainty expressed at approximately the 95% confidence level using a coverage factor of k=2.

### 3. Power Line Conducted Emission Test

#### 3.1. Test equipment

Item	Equipment	Manufacturer	Model No.	Serial No.	Last Cal.	Cal. Interval
1	Test Receiver	R&S	ESPI	100146	2023-05-20	1 Year
2	LISN	R&S	ENV216	3650.6550.06	2023-05-19	1 Year
3	LISN	R&S	ENV4200	1107.2387.04	2023-05-19	1 Year
4	RF Cable	HUBER	SUCOFLEX100	30722/4E	2023-05-19	2 Year
5	MEASUREMENT SOFTWARE	FARAD	EZ-EMC(VER:1.1.4.2)	N/A	N/A	N/A

#### 3.2. BLOCK DIAGRAM OF TEST SETUP

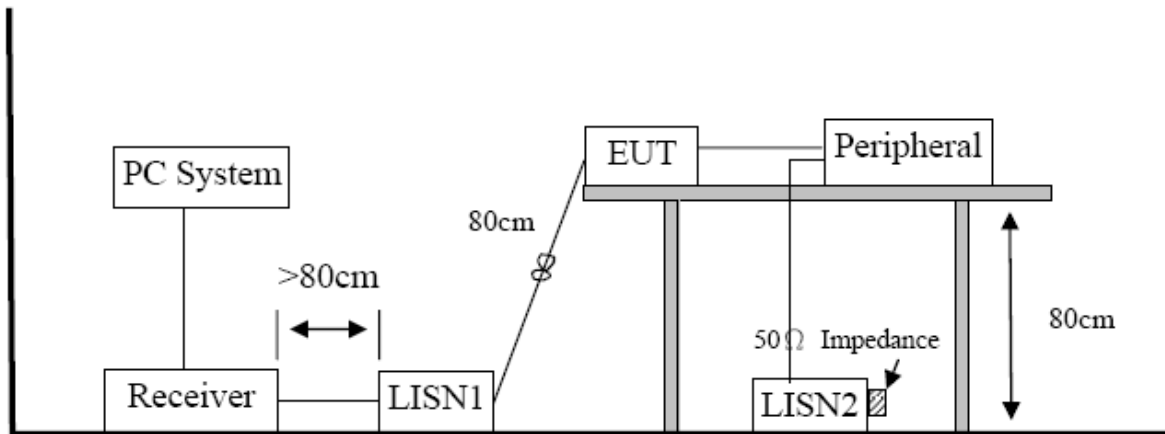

#### 3.3. Power Line Conducted Emission Limits (Class B)

Frequency	Quasi-Peak Level dB(μV)	Average Level dB(μV)
150kHz ~ 500kHz	66 ~ 56*	56 ~ 46*
500kHz ~ 5MHz	56	46
5MHz ~ 30MHz	60	50

Note 1: \* Decreasing linearly with logarithm of frequency.

Note 2: The lower limit shall apply at the transition frequencies.



### 3.4. Test Procedure

The EUT and Support equipment, if needed, were put placed on a non-metallic table, 80cm above the ground plane.

Configuration EUT to simulate typical usage as described in clause 2.3 and test equipment as described in clause 3.2 of this report.

All I/O cables were positioned to simulate typical actual usage as per ANSI C63.10.

All support equipment power received from a second LISN.

Emissions were measured on each current carrying line of the EUT using an EMI Test Receiver connected to the LISN powering the EUT.

The Receiver scanned from 150 kHz to 30MHz for emissions in each of the test modes.

During the above scans, the emissions were maximized by cable manipulation.

The test mode(s) described in clause 2.3 were scanned during the preliminary test.

After the preliminary scan, we found the test mode producing the highest emission level.

The EUT configuration and worse cable configuration of the above highest emission levels were recorded for reference of the final test.

EUT and support equipment were set up on the test bench as per the configuration with highest emission level in the preliminary test.

A scan was taken on both power lines, Neutral and Line, recording at least the six highest emissions. Emission frequency and amplitude were recorded into a computer in which correction factors were used to calculate the emission level and compare reading to the applicable limit.

The test data of the worst-case condition(s) was recorded.

The bandwidth of test receiver is set at 9 KHz.

### 3.5. Test Result

**PASS. (See below detailed test result)**

Note1: All emissions not reported below are too low against the prescribed limits.

Note2: "-----" means Peak detection; "-----" means Average detection

Note3: Measurement = Reading Level + Factor, Margin= Measurement-Limit

# Conducted Emission Test Result

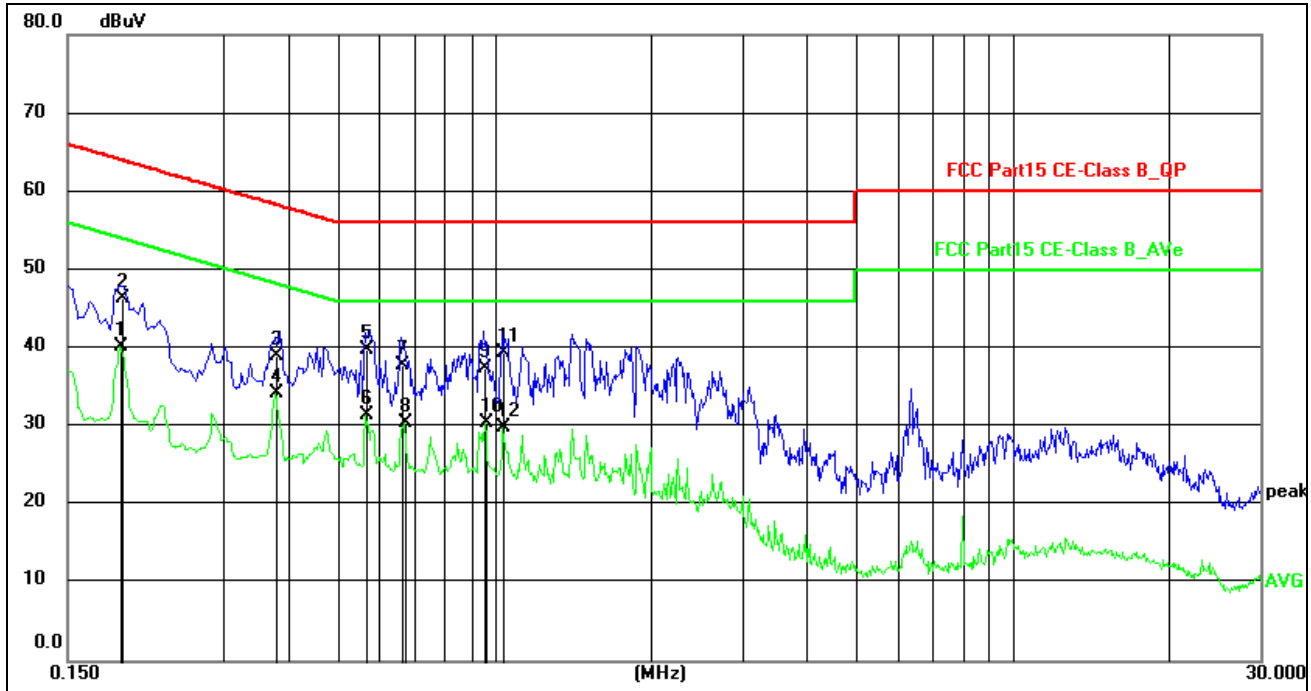

Site:	844 LAB	Phase:L1	Temperature(C):24(C)
Limit:	FCC Part15 CE-Class B_QP		Humidity(%):63%
EUT:	LED Driver	Test Time:	2024/3/26 11:02:53
M/N.:	BXDR-PS-20BS-U405W-01-A	Power Rating:	AC120V/60Hz
Mode:	2.4G WIFI	Test Engineer:	
Note:			

No.	Frequency (MHz)	Reading Level(dBuV)	Factor (dB)	Measurement(dBuV)	Limit (dBuV)	Margin (dB)	Detector	Comment
1 *	0.1900	29.03	11.14	40.17	54.04	-13.87	AVG	
2	0.1904	35.19	11.14	46.33	64.02	-17.69	QP	
3	0.3780	27.78	11.18	38.96	58.32	-19.36	QP	
4	0.3780	23.03	11.18	34.21	48.32	-14.11	AVG	
5	0.5655	28.66	11.21	39.87	56.00	-16.13	QP	
6	0.5660	20.23	11.21	31.44	46.00	-14.56	AVG	
7	0.6620	26.58	11.23	37.81	56.00	-18.19	QP	
8	0.6700	19.32	11.23	30.55	46.00	-15.45	AVG	
9	0.9580	26.24	11.22	37.46	56.00	-18.54	QP	
10	0.9620	19.22	11.22	30.44	46.00	-15.56	AVG	
11	1.0380	28.14	11.22	39.36	56.00	-16.64	QP	
12	1.0380	18.73	11.22	29.95	46.00	-16.05	AVG	

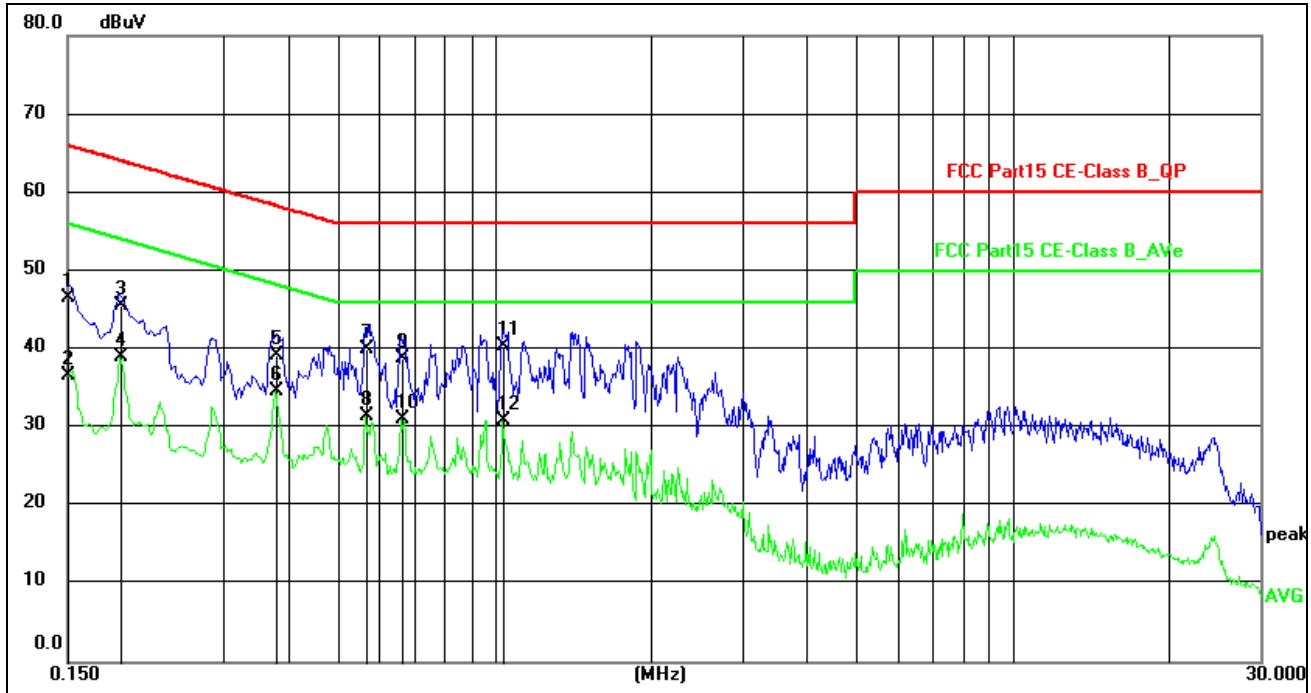

Site:	844 LAB	Phase:	N	Temperature(C):	24(C)
Limit:	FCC Part15 CE-Class B_QP	Test Time:	2024/3/26 10:56:53	Humidity(%):	63%
EUT:	LED Driver	Power Rating:	AC120V/60Hz	Test Engineer:	
M/N.:	BXDR-PS-20BS-U405W-01-A	Note:			
Mode:	2.4G WIFI				

No.	Frequency (MHz)	Reading Level(dBuV)	Factor (dB)	Measurement(dBuV)	Limit (dBuV)	Margin (dB)	Detector	Comment
1	0.1503	35.46	11.15	46.61	65.98	-19.37	QP	
2	0.1503	25.55	11.15	36.70	55.98	-19.28	AVG	
3	0.1900	34.35	11.16	45.51	64.04	-18.53	QP	
4	0.1900	27.77	11.16	38.93	54.04	-15.11	AVG	
5	0.3780	27.93	11.27	39.20	58.32	-19.12	QP	
6 *	0.3780	23.31	11.27	34.58	48.32	-13.74	AVG	
7	0.5660	28.65	11.29	39.94	56.00	-16.06	QP	
8	0.5660	20.24	11.29	31.53	46.00	-14.47	AVG	
9	0.6620	27.63	11.27	38.90	56.00	-17.10	QP	
10	0.6620	19.88	11.27	31.15	46.00	-14.85	AVG	
11	1.0380	29.26	11.23	40.49	56.00	-15.51	QP	
12	1.0380	19.61	11.23	30.84	46.00	-15.16	AVG	

## 4. Radiated emission test

### 4.1. Test equipment

Item	Equipment	Manufacturer	Model No.	Serial No.	Last Cal.	Cal. Interval
1	EMI Test Receiver	R&S	ESR	7250-30406 7528	2023-05-20	1 Year
2	Trilog Broadband Antenna	Schwarzbeck	VULB9168	00969	2023-05-22	2 Year
3	Pre-amplifier	R&S	8449B	3113A04553	2023-05-19	1 Year
4	Active Loop antenna	Schwarzbeck	FMZB-1519	1519-038	2023-05-19	1 Year
5	Horn antenna	Schwarzbeck	BBHA9120D	453	2023-05-19	2 Year
6	Double Ridged Horn Antenna	A.H. System	SAS-574	584	2023-05-19	1 Year
7	Pre-amplifier	R&S	SCU18	105326	2023-05-19	1 Year
8	RF Cable	GORE	OSQ01Q010 78.7	SN1545847 3	2023-05-19	1 Year
9	RF Cable	GORE	OSQ01Q010 78.7	SN1545847 4	2023-05-19	1 Year
10	RF Cable	ESCO	ETS-LINGR EN	RFC-SMS-1 00-SMS-340 -IN	2023-05-19	1 Year
11	Measurement software	Farad	EZ-EMC(VE R:1.1.4.2)	N/A	N/A	N/A

#### 4.2. Block diagram of test setup

In 3m Anechoic Chamber Test Setup Diagram for 9KHz to 30MHz:

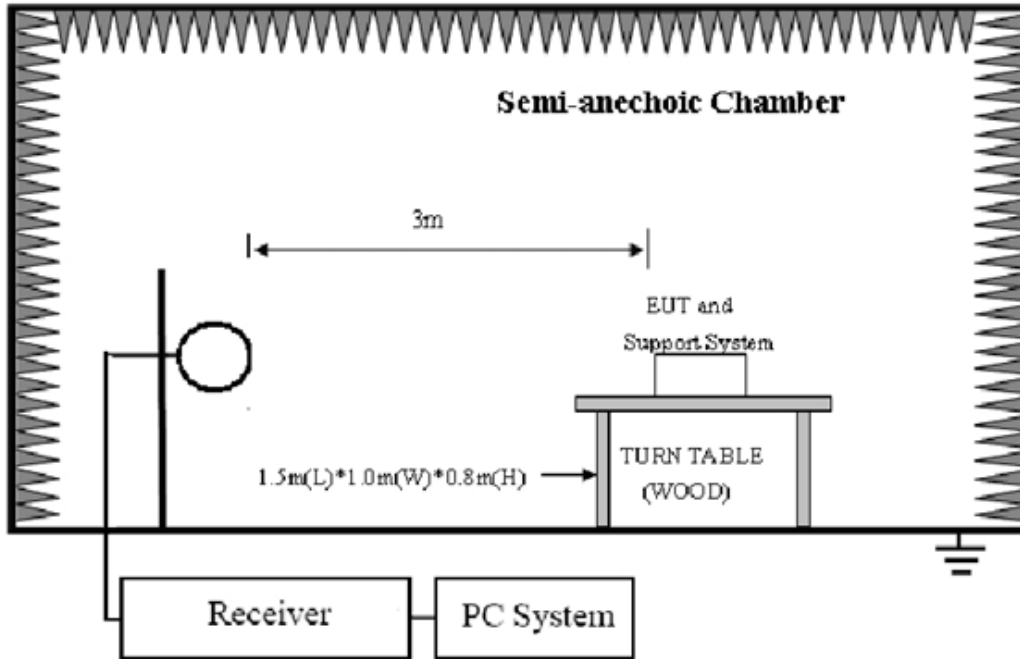

In 3m Anechoic Chamber Test Setup Diagram for 30MHz to 1GHz:

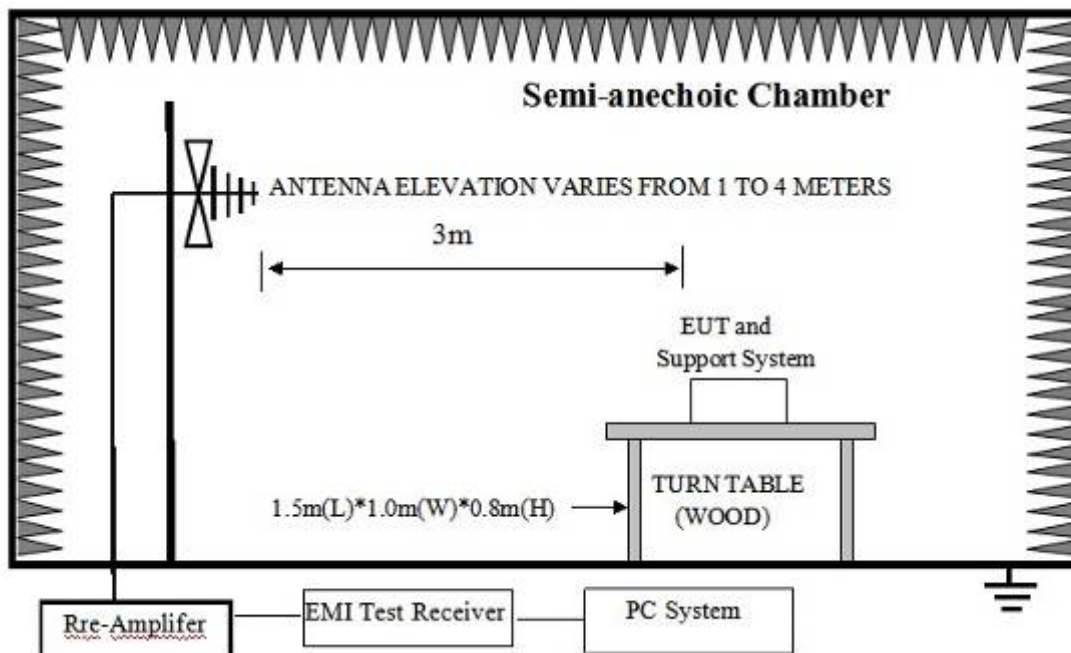

In 3m Anechoic Chamber Test Setup Diagram for frequency above 1GHz:

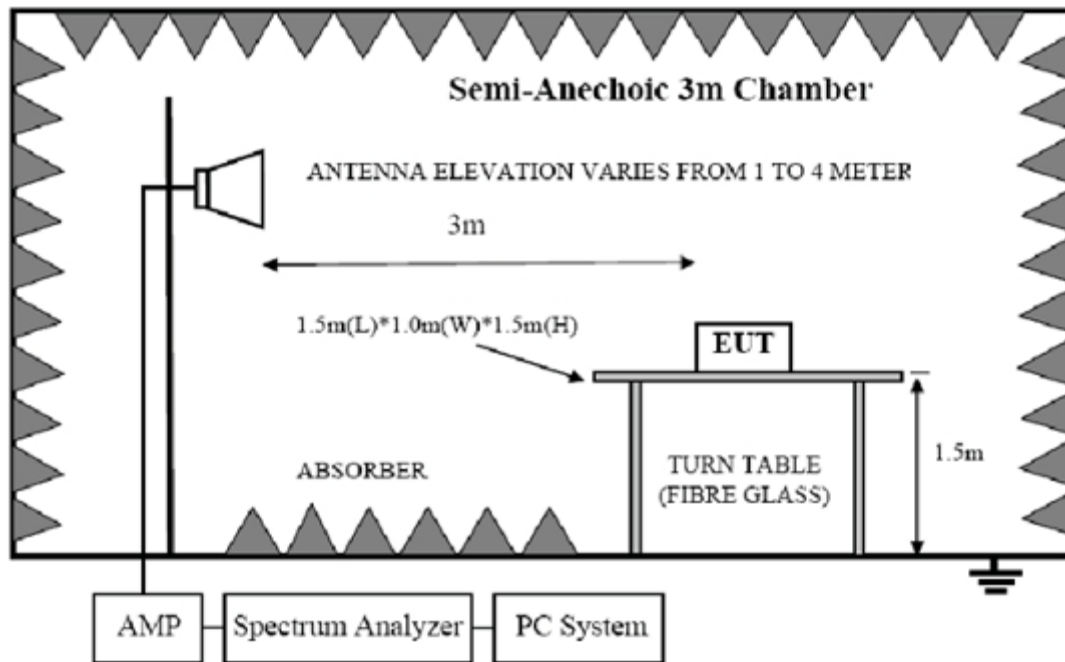

### 4.3. Limit

FCC 15.205 Restricted frequency band:

MHz	MHz	MHz	GHz
0.090 - 0.110	16.42 - 16.423	399.9 - 410	4.5 - 5.15
<sup>1</sup> 0.495 - 0.505	16.69475 - 16.69525	608 - 614	5.35 - 5.46
2.1735 - 2.1905	16.80425 - 16.80475	960 - 1240	7.25 - 7.75
4.125 - 4.128	25.5 - 25.67	1300 - 1427	8.025 - 8.5
4.17725 - 4.17775	37.5 - 38.25	1435 - 1626.5	9.0 - 9.2
4.20725 - 4.20775	73 - 74.6	1645.5 - 1646.5	9.3 - 9.5
6.215 - 6.218	74.8 - 75.2	1660 - 1710	10.6 - 12.7
6.26775 - 6.26825	108 - 121.94	1718.8 - 1722.2	13.25 - 13.4
6.31175 - 6.31225	123 - 138	2200 - 2300	14.47 - 14.5
8.291 - 8.294	149.9 - 150.05	2310 - 2390	15.35 - 16.2
8.362 - 8.366	156.52475 - 156.52525	2483.5 - 2500	17.7 - 21.4
8.37625 - 8.38675	156.7 - 156.9	2690 - 2900	22.01 - 23.12
8.41425 - 8.41475	162.0125 - 167.17	3260 - 3267	23.6 - 24.0
12.29 - 12.293	167.72 - 173.2	3332 - 3339	31.2 - 31.8
12.51975 - 12.52025	240 - 285	3345.8 - 3358	36.43 - 36.5
12.57675 - 12.57725	322 - 335.4	3600 - 4400	( <sup>2</sup> )

FCC 15.109 Limit

Frequency (MHz)	Distance (Meters)	Field Strengths Limits dB(μV)/m
30--88	3	40.0
88--216	3	43.5
216--960	3	46.0
960--1000	3	54.0
Above 1GHz	3	Peak: 74.0
	3	Average:54.0

Note: (1) The smaller limit shall apply at the cross point between two frequency bands.

(2)Distance is the distance in meters between the measuring instrument, antenna and the closest point of any part of the device or system.

(3)The emission limits shown in the above table are based on measurements employing a CISPR QP detector except for the frequency bands 9-90KHz, 110-490KHz and above 1000MHz.Radiated emissions limits in these three bands are based on measurements employing an average detector.

(4) At frequencies below 30MHz, measurement may be performed at a distance closer then that specified, and the limit at closer measurement distance can be extrapolated by below formula:

$$\text{Limit } 3m(\text{dBuV}/m) = \text{Limit}30m(\text{dBuV}/m) + 40\text{Log}(30m/3m)$$

(5)All the emissions appearing within 15.205 restricted frequency bands shall not exceed the limits shown in 15.109, all the other emissions shall be at least 20dB below the fundamental emissions, or comply with 15.109 limits.

#### 4.4. Test Procedure

##### Procedure of Preliminary Test

Configuration EUT to simulate typical usage as described in clause 2.3 and test equipment as described in clause 4.2 of this report.

Mains cables, telephone lines or other connections to auxiliary equipment located outside the test are shall drape to the floor, be fitted with ferrite clamps or ferrite tubes placed on the floor at the point where the cable reaches the floor and then routed to the place where they leave the turntable. No extension cords shall be used to mains receptacle.

EUT height should be 0.8m for below 1GHz and 1.5m for above 1GHz at ground with absorbers.

The antenna was placed at 3 meter away from the EUT as stated in ANSI C63.10. The antenna connected to the Spectrum Analyzer via a cable and at times a pre-amplifier would be used.

The Analyzer / Receiver quickly scanned from 30MHz to 18GHz. The EUT test program was started. Emissions were scanned and measured rotating the EUT to 360 degrees and positioning the antenna 1 to 4 meters above the ground plane, in both the vertical and the horizontal polarization, to maximize the emission reading level.

The X, Y, Z three axial are tested and the report only the worst case.

The emissions from 9KHz to 1GHz, QP or average values were measured with EMI receiver with below RBW:

Frequency band	RBW
9KHz-150KHz	200Hz
150KHz-30MHz	9KHz
30MHz-1GHz	120KHz

For emissions above 1GHz, both Peak and Average level were measured with Spectrum Analyzer, and the RBW is set at 1MHz, VBW is set at 3MHz for Peak measure; RMS detector RBW 1MHz VBW 3MHz for Average measure.

#### 4.5. Test result

##### **PASS. (See below detailed test result)**

Radiated Emissions Test Data Below 30MHz:

No emission found between lowest internal used/generated frequencies to 30MHz.



# Radiated Emission Test Result

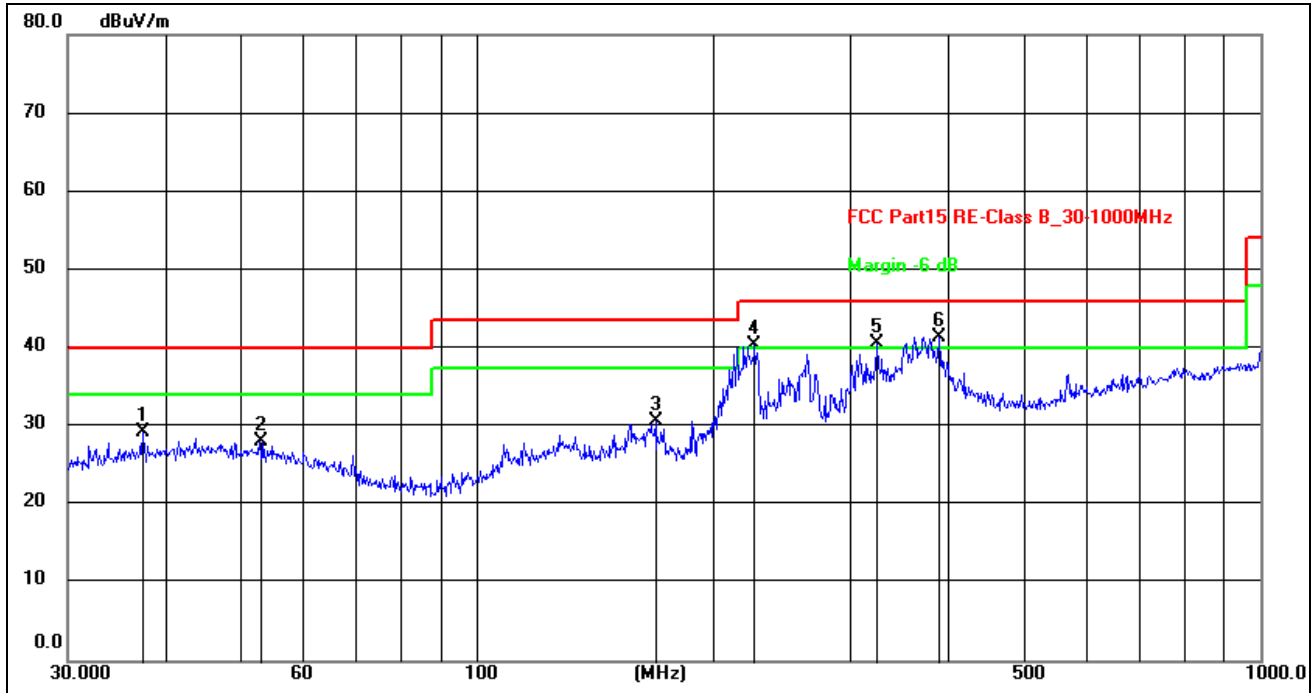

Site:	966LAB	Antenna::	Horizontal	Temperature(C):	24(C)
Limit:	FCC Part15 RE-Class B_30-1000MHz			Humidity(%):	60%
EUT:	LED Driver	Test Time:	2024/3/25 17:10:34		
M/N.:	BXDR-PS-20BS-U405W-01-A	Power Rating:	AC 120V/60Hz		
Mode:	High gears with Tx mode	Test Engineer:			
Note:	(802.11 b 2412MHz-Worst case)				

No.	Frequency (MHz)	Reading (dBuV)	Factor (dB/m)	Level (dBuV/m)	Limit (dBuV/m)	Margin (dB)	Det.	Height (cm)	Azimuth (deg)	Remark
1	37.4164	15.42	13.90	29.32	40.00	-10.68	peak	200	329	
2	52.7600	14.35	13.81	28.16	40.00	-11.84	peak	200	77	
3	169.0053	16.09	14.56	30.65	43.50	-12.85	peak	200	268	
4 !	226.0994	27.93	12.52	40.45	46.00	-5.55	peak	200	236	
5 !	324.4560	25.45	15.20	40.65	46.00	-5.35	peak	100	148	
6 *	389.3548	24.88	16.53	41.41	46.00	-4.59	peak	100	220	

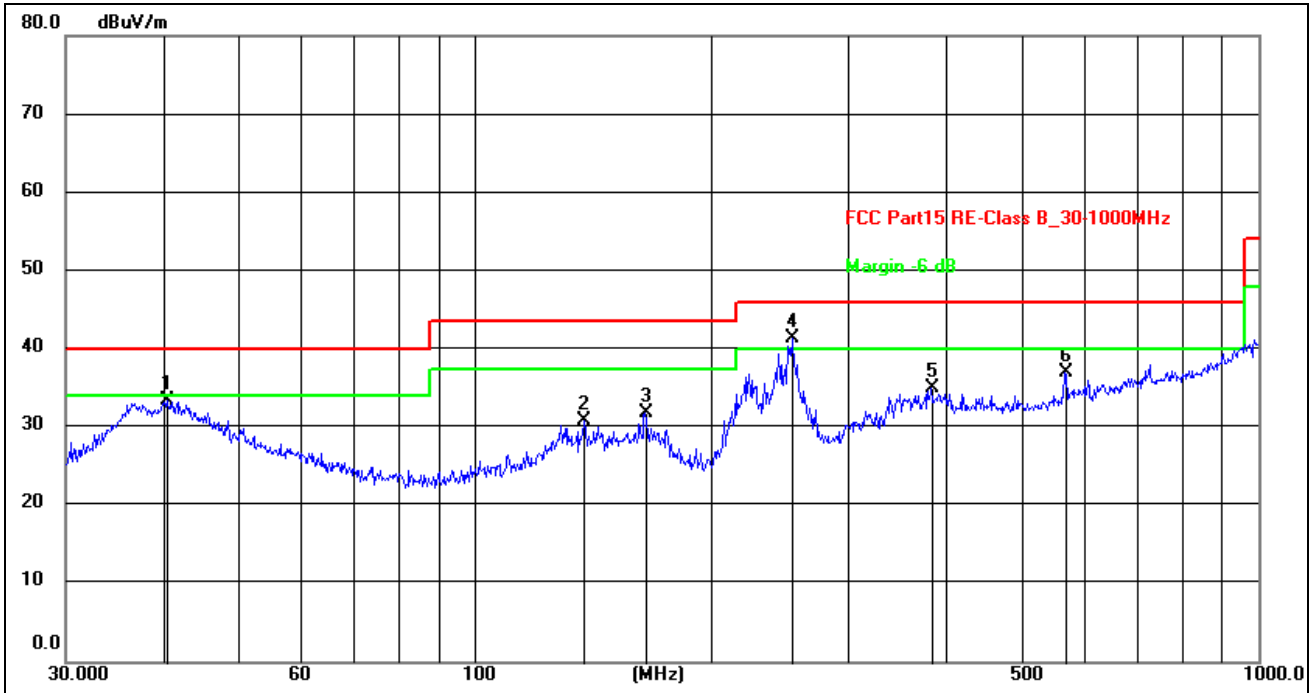

Site:	966LAB	Antenna::	Vertical	Temperature(C):	24(C)
Limit:	FCC Part15 RE-Class B_30-1000MHz			Humidity(%):	60%
EUT:	LED Driver	Test Time:	2024/3/25 17:13:10		
M/N.:	BXDR-PS-20BS-U405W-01-A	Power Rating:	AC 120V/60Hz		
Mode:	High gears with Tx mode	Test Engineer:			
Note:	(802.11 b 2412MHz-Worst case)				

No.	Frequency (MHz)	Reading (dBuV)	Factor (dB/m)	Level (dBuV/m)	Limit (dBuV/m)	Margin (dB)	Det.	Height (cm)	Azimuth (deg)	Remark
1	40.4172	18.85	14.67	33.52	40.00	-6.48	peak	100	231	
2	137.9028	16.16	14.61	30.77	43.50	-12.73	peak	100	341	
3	164.9075	16.90	15.00	31.90	43.50	-11.60	peak	100	267	
4 *	253.8367	28.05	13.27	41.32	46.00	-4.68	peak	100	134	
5	382.5879	18.60	16.39	34.99	46.00	-11.01	peak	100	223	
6	566.6223	16.86	20.25	37.11	46.00	-8.89	peak	100	51	

<b>Site:</b>	<b>966 LAB</b>	<b>Antenna::H / V</b>	<b>Temperature(C):24(C)</b>
<b>Limit:</b>	<b>FCC Part 15.247</b>		<b>Humidity(%):60%</b>
<b>EUT:</b>	<b>LED Driver</b>	<b>Test Time:</b>	<b>2023/10/22</b>
<b>M/N.:</b>	<b>BXDR-PS-20BS-U405W-01-A</b>	<b>Power Rating:</b>	<b>AC 120V/60Hz</b>
<b>Mode:</b>	<b>Tx mode (2412MHz)</b>	<b>Test Engineer:</b>	
<b>Note:</b>	<b>802.11 b 11M</b>		

Frequency (MHz)	Reading (dBUV)	Factor (dB/m)	Pre-amp (dB)	Cable lost (dB)	Result (dBUV/m)	Limit (dBUV/m)	Margin (dB)	Detect	Antenna polarization
2390.00	58.55	26.33	40.23	8.46	53.11	74.00	-20.89	peak	H
2390.00	44.93	26.33	40.23	8.46	39.49	54.00	-14.51	AVG	H
2400.00	55.91	26.38	40.20	8.49	50.58	74.00	-23.42	peak	H
2400.00	46.64	26.38	40.20	8.49	41.31	54.00	-12.69	AVG	H
4824.00	64.22	26.41	40.21	8.51	58.93	74.00	-15.07	peak	H
4824.00	49.00	26.41	40.21	8.51	43.71	54.00	-10.29	AVG	H
7236.00	57.54	31.01	40.19	9.53	57.89	74.00	-16.11	peak	H
7236.00	43.89	31.01	40.19	9.53	44.24	54.00	-9.76	AVG	H
2390.00	57.96	26.33	40.23	8.46	52.52	74.00	-21.48	peak	V
2390.00	45.22	26.33	40.23	8.46	39.78	54.00	-14.22	AVG	V
2400.00	54.40	26.38	40.20	8.49	49.07	74.00	-24.93	peak	V
2400.00	45.78	26.38	40.20	8.49	40.45	54.00	-13.55	AVG	V
4824.00	63.66	26.41	40.21	8.51	58.37	74.00	-15.63	peak	V
4824.00	48.64	26.41	40.21	8.51	43.35	54.00	-10.65	AVG	V
7236.00	57.75	31.01	40.19	9.53	58.10	74.00	-15.90	peak	V
7236.00	44.60	31.01	40.19	9.53	44.95	54.00	-9.05	AVG	V

Note: 1. Result Level = Reading Level + Antenna Factor + Cable loss – Pre-amp Factor.

2. Antenna polarization: "H" means Horizontal, "V" means Vertical.

<b>Site:</b>	<b>966 LAB</b>	<b>Antenna::H / V</b>	<b>Temperature(C):24(C)</b>
<b>Limit:</b>	<b>FCC Part 15.247</b>		<b>Humidity(%):60%</b>
<b>EUT:</b>	<b>LED Driver</b>	<b>Test Time:</b>	<b>2023/10/22</b>
<b>M/N.:</b>	<b>BXDR-PS-20BS-U405W-01-A</b>	<b>Power Rating:</b>	<b>AC 120V/60Hz</b>
<b>Mode:</b>	<b>Tx mode (2437MHz)</b>	<b>Test Engineer:</b>	
<b>Note:</b>	<b>802.11 b 11M</b>		

Frequency (MHz)	Reading (dBuV)	Factor (dB/m)	Pre-amp (dB)	Cable lost (dB)	Result (dBuV/m)	Limit (dBuV/m)	Margin (dB)	Detect	Antenna polarization
4874.00	62.58	31.04	40.19	9.59	63.02	74.00	-10.98	peak	H
4874.00	38.99	31.04	40.19	9.59	39.43	54.00	-14.57	AVG	H
7311.00	54.82	35.25	40.47	12.22	61.82	74.00	-12.18	peak	H
7311.00	40.10	35.25	40.47	12.22	47.10	54.00	-6.90	AVG	H
4874.00	53.86	31.04	40.19	9.59	54.30	74.00	-19.70	peak	V
4874.00	37.70	31.04	40.19	9.59	38.14	54.00	-15.86	AVG	V
7311.00	53.32	35.25	40.47	12.22	60.32	74.00	-13.68	peak	V
7311.00	40.76	35.25	40.47	12.22	47.76	54.00	-6.24	AVG	V

Note: 1. Result Level = Reading Level + Antenna Factor + Cable loss – Pre-amp Factor.

2. Antenna polarization: “H” means Horizontal, “V” means Vertical.

<b>Site:</b>	<b>966 LAB</b>	<b>Antenna::H / V</b>	<b>Temperature(C):24(C)</b>
<b>Limit:</b>	<b>FCC Part 15.247</b>		<b>Humidity(%):60%</b>
<b>EUT:</b>	<b>LED Driver</b>	<b>Test Time:</b>	<b>2023/10/22</b>
<b>M/N.:</b>	<b>BXDR-PS-20BS-U405W-01-A</b>	<b>Power Rating:</b>	<b>AC 120V/60Hz</b>
<b>Mode:</b>	<b>Tx mode (2462MHz)</b>	<b>Test Engineer:</b>	
<b>Note:</b>	<b>802.11 b 11M</b>		

Frequency (MHz)	Reading (dBuV)	Factor (dB/m)	Pre-amp (dB)	Cable lost (dB)	Result (dBuV/m)	Limit (dBuV/m)	Margin (dB)	Detect	Antenna polarization
2483.50	42.84	26.56	40.29	8.65	37.76	74.00	-36.24	peak	H
2483.50	34.66	26.56	40.29	8.65	29.58	54.00	-24.42	AVG	H
4924.00	59.99	26.51	40.21	8.54	54.83	74.00	-19.17	peak	H
4924.00	48.99	26.51	40.21	8.54	43.83	54.00	-10.17	AVG	H
7386.00	52.08	31.04	40.19	9.62	52.55	74.00	-21.45	peak	H
7386.00	40.28	31.04	40.19	9.62	40.75	54.00	-13.25	AVG	H
2483.50	59.22	26.56	40.29	8.65	54.14	74.00	-19.86	peak	V
2483.50	47.48	26.56	40.29	8.65	42.40	54.00	-11.60	AVG	V
4924.00	56.83	26.51	40.21	8.54	51.67	55.00	-3.33	peak	V
4924.00	44.97	26.51	40.21	8.54	39.81	56.00	-16.19	AVG	V
7386.00	46.47	31.04	40.19	9.62	46.94	57.00	-10.06	peak	V
7386.00	39.62	31.04	40.19	9.62	40.09	58.00	-17.91	AVG	V

Note: 1. Result Level = Reading Level + Antenna Factor + Cable loss – Pre-amp Factor.

2. Antenna polarization: “H” means Horizontal, “V” means Vertical.

<b>Site:</b>	<b>966 LAB</b>	<b>Antenna::H / V</b>	<b>Temperature(C):24(C)</b>
<b>Limit:</b>	<b>FCC Part 15.247</b>		<b>Humidity(%):60%</b>
<b>EUT:</b>	<b>LED Driver</b>	<b>Test Time:</b>	<b>2023/10/22</b>
<b>M/N.:</b>	<b>BXDR-PS-20BS-U405W-01-A</b>	<b>Power Rating:</b>	<b>AC 120V/60Hz</b>
<b>Mode:</b>	<b>Tx mode (2412MHz)</b>	<b>Test Engineer:</b>	
<b>Note:</b>	<b>802.11 g 54M</b>		

Frequency (MHz)	Reading (dBuV)	Factor (dB/m)	Pre-amp (dB)	Cable lost (dB)	Result (dBuV/m)	Limit (dBuV/m)	Margin (dB)	Detect	Antenna polarization
2390.00	58.39	26.33	40.23	8.46	52.95	74.00	-21.05	peak	H
2390.00	45.36	26.33	40.23	8.46	39.92	54.00	-14.08	AVG	H
2400.00	54.93	26.38	40.20	8.49	49.60	74.00	-24.40	peak	H
2400.00	46.17	26.38	40.20	8.49	40.84	54.00	-13.16	AVG	H
4824.00	63.19	26.41	40.21	8.51	57.90	74.00	-16.10	peak	H
4824.00	49.00	26.41	40.21	8.51	43.71	54.00	-10.29	AVG	H
7236.00	58.22	31.01	40.19	9.53	58.57	74.00	-15.43	peak	H
7236.00	44.52	31.01	40.19	9.53	44.87	54.00	-9.13	AVG	H
2390.00	58.03	26.33	40.23	8.46	52.59	74.00	-21.41	peak	V
2390.00	46.18	26.33	40.23	8.46	40.74	54.00	-13.26	AVG	V
2400.00	54.04	26.38	40.20	8.49	48.71	74.00	-25.29	peak	V
2400.00	45.26	26.38	40.20	8.49	39.93	54.00	-14.07	AVG	V
4824.00	63.38	26.41	40.21	8.51	58.09	74.00	-15.91	peak	V
4824.00	47.56	26.41	40.21	8.51	42.27	54.00	-11.73	AVG	V
7236.00	58.18	31.01	40.19	9.53	58.53	74.00	-15.47	peak	V
7236.00	45.18	31.01	40.19	9.53	45.53	54.00	-8.47	AVG	V

Note: 1. Result Level = Reading Level + Antenna Factor + Cable loss – Pre-amp Factor.

2. Antenna polarization: “H” means Horizontal, “V” means Vertical.

<b>Site:</b>	<b>966 LAB</b>	<b>Antenna::H / V</b>	<b>Temperature(C):24(C)</b>
<b>Limit:</b>	<b>FCC Part 15.247</b>		<b>Humidity(%):60%</b>
<b>EUT:</b>	<b>LED Driver</b>	<b>Test Time:</b>	<b>2023/12/22</b>
<b>M/N.:</b>	<b>BXDR-PS-20BS-U405W-01-A</b>	<b>Power Rating:</b>	<b>AC 120V/60Hz</b>
<b>Mode:</b>	<b>Tx mode (2437MHz)</b>	<b>Test Engineer:</b>	
<b>Note:</b>	<b>802.11 g 54M</b>		

Frequency (MHz)	Reading (dBuV)	Factor (dB/m)	Pre-amp (dB)	Cable lost (dB)	Result (dBuV/m)	Limit (dBuV/m)	Margin (dB)	Detect	Antenna polarization
4874.00	61.48	31.04	40.19	9.59	61.92	74.00	-12.08	peak	H
4874.00	38.73	31.04	40.19	9.59	39.17	54.00	-14.83	AVG	H
7311.00	55.15	35.25	40.47	12.22	62.15	74.00	-11.85	peak	H
7311.00	41.74	35.25	40.47	12.22	48.74	54.00	-5.26	AVG	H
4874.00	55.29	31.04	40.19	9.59	55.73	74.00	-18.27	peak	V
4874.00	37.24	31.04	40.19	9.59	37.68	54.00	-16.32	AVG	V
7311.00	52.96	35.25	40.47	12.22	59.96	74.00	-14.04	peak	V
7311.00	41.97	35.25	40.47	12.22	48.97	54.00	-5.03	AVG	V

Note: 1. Result Level = Reading Level + Antenna Factor + Cable loss – Pre-amp Factor.

2. Antenna polarization: “H” means Horizontal, “V” means Vertical.

<b>Site:</b>	<b>966 LAB</b>	<b>Antenna::H / V</b>	<b>Temperature(C):24(C)</b>
<b>Limit:</b>	<b>FCC Part 15.247</b>		<b>Humidity(%):60%</b>
<b>EUT:</b>	<b>LED Driver</b>	<b>Test Time:</b>	<b>2023/12/22</b>
<b>M/N.:</b>	<b>BXDR-PS-20BS-U405W-01-A</b>	<b>Power Rating:</b>	<b>AC 120V/60Hz</b>
<b>Mode:</b>	<b>Tx mode (2462MHz)</b>	<b>Test Engineer:</b>	
<b>Note:</b>	<b>802.11 g 54M</b>		

Frequency (MHz)	Reading (dBUV)	Factor (dB/m)	Pre-amp (dB)	Cable lost (dB)	Result (dBUV/m)	Limit (dBUV/m)	Margin (dB)	Detect	Antenna polarization
2483.50	41.57	26.56	40.29	8.65	36.49	74.00	-37.51	peak	H
2483.50	35.10	26.56	40.29	8.65	30.02	54.00	-23.98	AVG	H
4924.00	59.30	26.51	40.21	8.54	54.14	74.00	-19.86	peak	H
4924.00	49.97	26.51	40.21	8.54	44.81	54.00	-9.19	AVG	H
7386.00	51.28	31.04	40.19	9.62	51.75	74.00	-22.25	peak	H
7386.00	39.44	31.04	40.19	9.62	39.91	54.00	-14.09	AVG	H
2483.50	59.62	26.56	40.29	8.65	54.54	74.00	-19.46	peak	V
2483.50	46.04	26.56	40.29	8.65	40.96	54.00	-13.04	AVG	V
4924.00	56.78	26.51	40.21	8.54	51.62	55.00	-3.38	peak	V
4924.00	45.83	26.51	40.21	8.54	40.67	56.00	-15.33	AVG	V
7386.00	46.94	31.04	40.19	9.62	47.41	57.00	-9.59	peak	V
7386.00	39.30	31.04	40.19	9.62	39.77	58.00	-18.23	AVG	V

Note: 1. Result Level = Reading Level + Antenna Factor + Cable loss – Pre-amp Factor.

2. Antenna polarization: "H" means Horizontal, "V" means Vertical.

<b>Site:</b>	<b>966 LAB</b>	<b>Antenna::H / V</b>	<b>Temperature(C):24(C)</b>
<b>Limit:</b>	<b>FCC Part 15.247</b>		<b>Humidity(%):60%</b>
<b>EUT:</b>	<b>LED Driver</b>	<b>Test Time:</b>	<b>2023/10/22</b>
<b>M/N.:</b>	<b>BXDR-PS-20BS-U405W-01-A</b>	<b>Power Rating:</b>	<b>AC 120V/60Hz</b>
<b>Mode:</b>	<b>Tx mode (2412MHz)</b>	<b>Test Engineer:</b>	
<b>Note:</b>	<b>802.11 n20</b>		

Frequency (MHz)	Reading (dBUV)	Factor (dB/m)	Pre-amp (dB)	Cable lost (dB)	Result (dBUV/m)	Limit (dBUV/m)	Margin (dB)	Detect	Antenna polarization
2390.00	59.39	26.33	40.23	8.46	53.95	74.00	-20.05	peak	H
2390.00	45.78	26.33	40.23	8.46	40.34	54.00	-13.66	AVG	H
2400.00	54.56	26.38	40.20	8.49	49.23	74.00	-24.77	peak	H
2400.00	46.83	26.38	40.20	8.49	41.50	54.00	-12.50	AVG	H
4824.00	63.52	26.41	40.21	8.51	58.23	74.00	-15.77	peak	H
4824.00	47.59	26.41	40.21	8.51	42.30	54.00	-11.70	AVG	H
7236.00	57.51	31.01	40.19	9.53	57.86	74.00	-16.14	peak	H
7236.00	44.85	31.01	40.19	9.53	45.20	54.00	-8.80	AVG	H
2390.00	58.70	26.33	40.23	8.46	53.26	74.00	-20.74	peak	V
2390.00	45.12	26.33	40.23	8.46	39.68	54.00	-14.32	AVG	V
2400.00	55.15	26.38	40.20	8.49	49.82	74.00	-24.18	peak	V
2400.00	46.10	26.38	40.20	8.49	40.77	54.00	-13.23	AVG	V
4824.00	63.86	26.41	40.21	8.51	58.57	74.00	-15.43	peak	V
4824.00	49.20	26.41	40.21	8.51	43.91	54.00	-10.09	AVG	V
7236.00	58.28	31.01	40.19	9.53	58.63	74.00	-15.37	peak	V
7236.00	43.71	31.01	40.19	9.53	44.06	54.00	-9.94	AVG	V

Note: 1. Result Level = Reading Level + Antenna Factor + Cable loss – Pre-amp Factor.

2. Antenna polarization: "H" means Horizontal, "V" means Vertical.

<b>Site:</b>	<b>966 LAB</b>	<b>Antenna::H / V</b>	<b>Temperature(C):24(C)</b>
<b>Limit:</b>	<b>FCC Part 15.247</b>		<b>Humidity(%):60%</b>
<b>EUT:</b>	<b>LED Driver</b>	<b>Test Time:</b>	<b>2023/10/22</b>
<b>M/N.:</b>	<b>BXDR-PS-20BS-U405W-01-A</b>	<b>Power Rating:</b>	<b>AC 120V/60Hz</b>
<b>Mode:</b>	<b>Tx mode (2437MHz)</b>	<b>Test Engineer:</b>	
<b>Note:</b>	<b>802.11 n20</b>		

Frequency (MHz)	Reading (dBuV)	Factor (dB/m)	Pre-amp (dB)	Cable lost (dB)	Result (dBuV/m)	Limit (dBuV/m)	Margin (dB)	Detect	Antenna polarization
4874.00	61.30	31.04	40.19	9.59	61.74	74.00	-12.26	peak	H
4874.00	38.22	31.04	40.19	9.59	38.66	54.00	-15.34	AVG	H
7311.00	54.53	35.25	40.47	12.22	61.53	74.00	-12.47	peak	H
7311.00	41.69	35.25	40.47	12.22	48.69	54.00	-5.31	AVG	H
4874.00	55.18	31.04	40.19	9.59	55.62	74.00	-18.38	peak	V
4874.00	37.00	31.04	40.19	9.59	37.44	54.00	-16.56	AVG	V
7311.00	52.47	35.25	40.47	12.22	59.47	74.00	-14.53	peak	V
7311.00	41.10	35.25	40.47	12.22	48.10	54.00	-5.90	AVG	V

Note: 1. Result Level = Reading Level + Antenna Factor + Cable loss – Pre-amp Factor.

2. Antenna polarization: “H” means Horizontal, “V” means Vertical.

<b>Site:</b>	<b>966 LAB</b>	<b>Antenna::H / V</b>	<b>Temperature(C):24(C)</b>
<b>Limit:</b>	<b>FCC Part 15.247</b>		<b>Humidity(%):60%</b>
<b>EUT:</b>	<b>LED Driver</b>	<b>Test Time:</b>	<b>2023/10/22</b>
<b>M/N.:</b>	<b>BXDR-PS-20BS-U405W-01-A</b>	<b>Power Rating:</b>	<b>AC 120V/60Hz</b>
<b>Mode:</b>	<b>Tx mode (2462MHz)</b>	<b>Test Engineer:</b>	
<b>Note:</b>	<b>802.11 n20</b>		

Frequency (MHz)	Reading (dBuV)	Factor (dB/m)	Pre-amp (dB)	Cable lost (dB)	Result (dBuV/m)	Limit (dBuV/m)	Margin (dB)	Detect	Antenna polarization
2483.50	41.63	26.56	40.29	8.65	36.55	74.00	-37.45	peak	H
2483.50	35.73	26.56	40.29	8.65	30.65	54.00	-23.35	AVG	H
4924.00	58.30	26.51	40.21	8.54	53.14	74.00	-20.86	peak	H
4924.00	49.55	26.51	40.21	8.54	44.39	54.00	-9.61	AVG	H
7386.00	51.07	31.04	40.19	9.62	51.54	74.00	-22.46	peak	H
7386.00	40.45	31.04	40.19	9.62	40.92	54.00	-13.08	AVG	H
2483.50	60.20	26.56	40.29	8.65	55.12	74.00	-18.88	peak	V
2483.50	47.46	26.56	40.29	8.65	42.38	54.00	-11.62	AVG	V
4924.00	56.83	26.51	40.21	8.54	51.67	55.00	-3.33	peak	V
4924.00	46.62	26.51	40.21	8.54	41.46	56.00	-14.54	AVG	V
7386.00	46.56	31.04	40.19	9.62	47.03	57.00	-9.97	peak	V
7386.00	39.75	31.04	40.19	9.62	40.22	58.00	-17.78	AVG	V

Note: 1. Result Level = Reading Level + Antenna Factor + Cable loss – Pre-amp Factor.

2. Antenna polarization: “H” means Horizontal, “V” means Vertical.



## 5. Output Power

### 5.1. Test equipment

Item	Equipment	Manufacturer	Model No.	Serial No.	Last Cal.	Cal. Interval
1	MXA Signal Analyzer	KEYSIGHT	N9020A	MY54510476	2023/05/19	1 Year

### 5.2. BLOCK DIAGRAM OF TEST SETUP

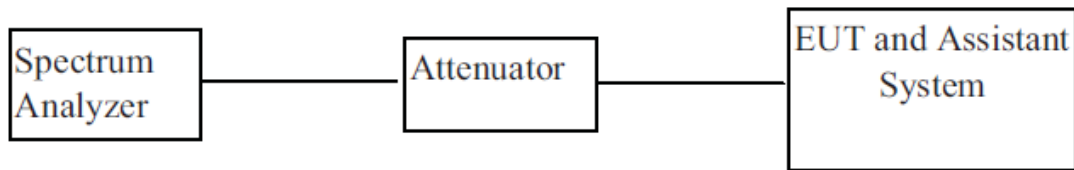

### 5.3. Limit

For systems using digital modulation in the 902-928 MHz, 2400-2483.5 MHz, and 5725-5850 MHz bands: 1 Watt (30dBm).

### 5.4. Test Procedure

For output power test:

1. Connect EUT RF output port to power sensor through an RF attenuator.
2. Connect the power sensor to the PC.
3. Set the EUT Work on the top, the middle and the bottom operation frequency individually.
4. Record the maximum power from the software.

Note : The EUT was tested according to KDB 558074v03r04 for compliance to FCC 47CFR 15.247 requirements.

### 5.5. Test result

Condition	Mode	Frequency (MHz)	Antenna	Conducted Power (dBm)	Duty Factor (dB)	Total Power (dBm)	Limit (dBm)	Verdict
NVNT	802.11b 1Mbps	2412	Ant 1	23.608	0	23.608	30	Pass
NVNT	802.11b 1Mbps	2437	Ant 1	22.839	0	22.839	30	Pass
NVNT	802.11b 1Mbps	2462	Ant 1	22.682	0	22.682	30	Pass

Power NVNT 802.11b 1Mbps 2412MHz Ant1

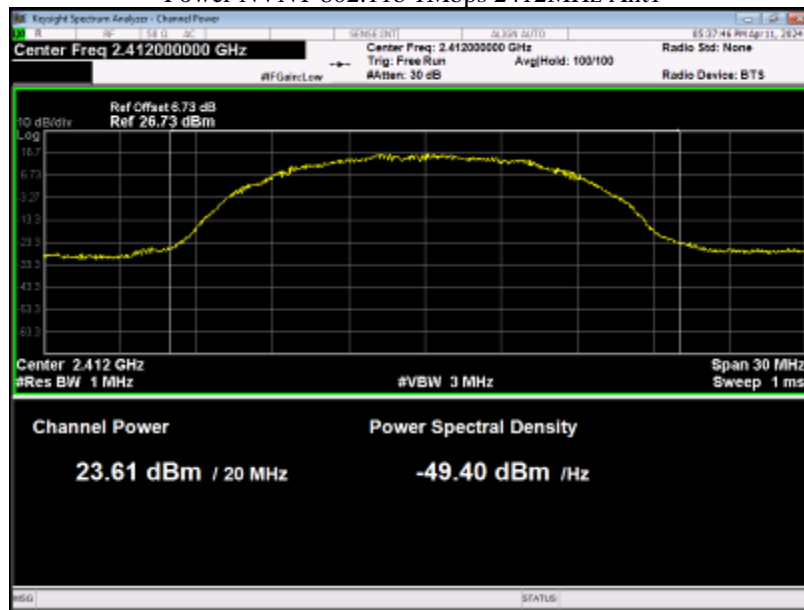

Power NVNT 802.11b 1Mbps 2437MHz Ant1

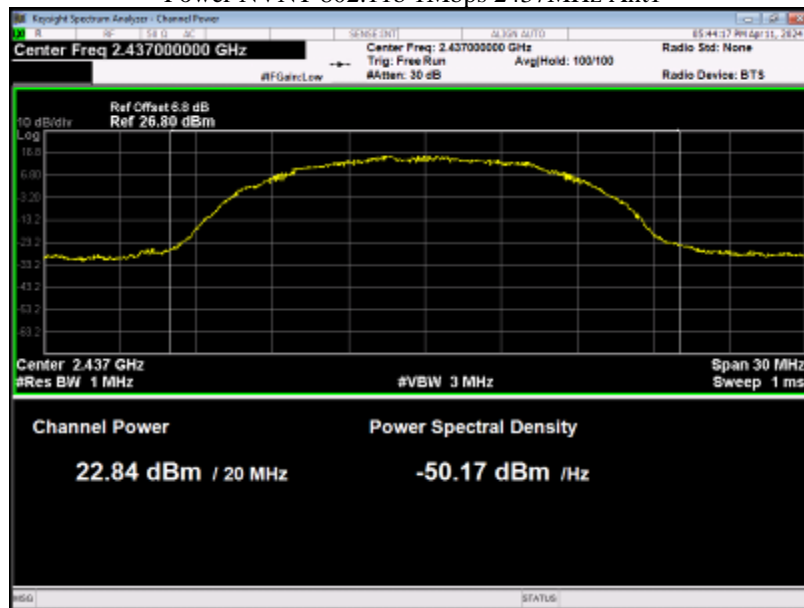

Power NVNT 802.11b 1Mbps 2462MHz Ant1

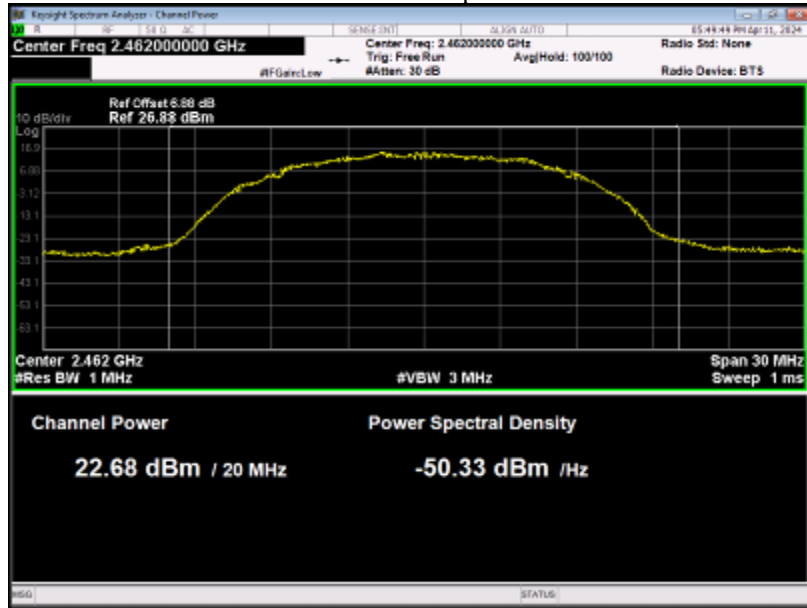

Condition	Mode	Frequency (MHz)	Antenna	Conducted Power (dBm)	Duty Factor (dB)	Total Power (dBm)	Limit (dBm)	Verdict
NVNT	802.11g 6Mbps	2412	Ant 1	20.999	0	20.999	30	Pass
NVNT	802.11g 6Mbps	2437	Ant 1	20.386	0	20.386	30	Pass
NVNT	802.11g 6Mbps	2462	Ant 1	20.17	0	20.17	30	Pass

Power NVNT 802.11g 6Mbps 2412MHz Ant1

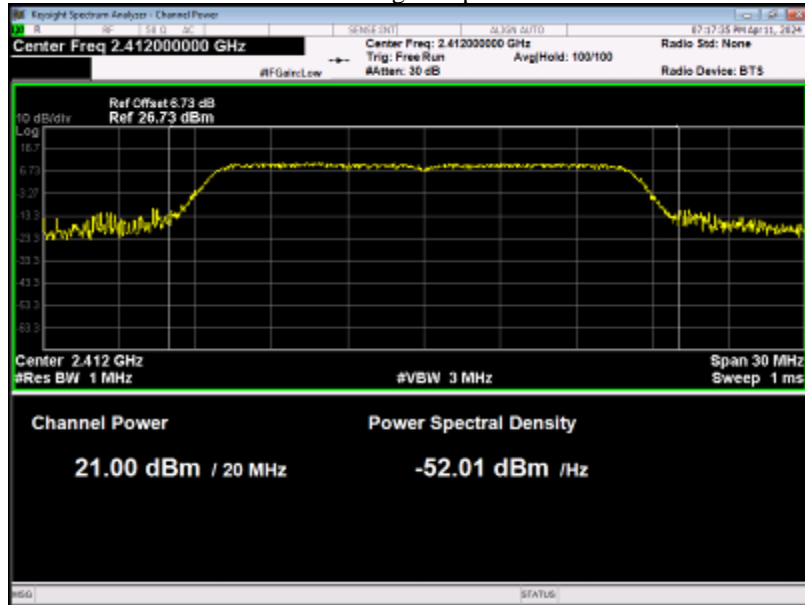

Power NVNT 802.11g 6Mbps 2437MHz Ant1

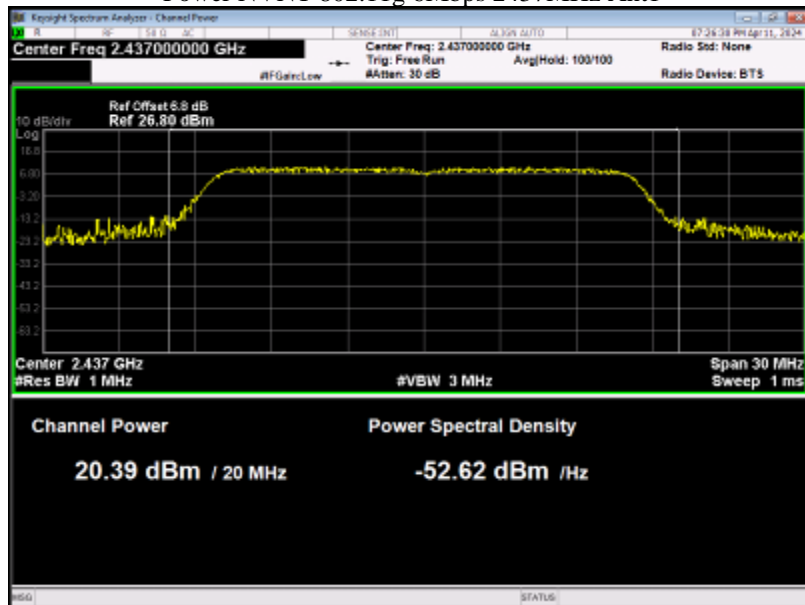

Power NVNT 802.11g 6Mbps 2462MHz Ant1

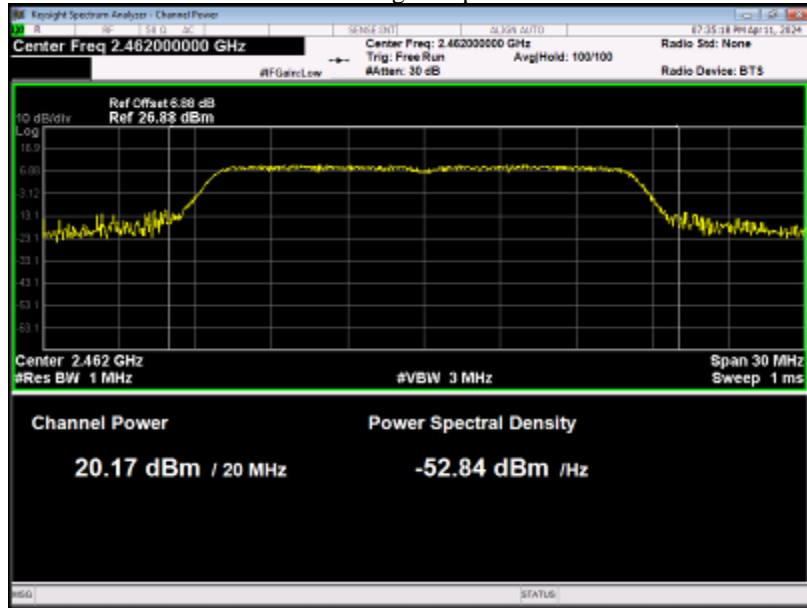

Condition	Mode	Frequency (MHz)	Antenna	Conducted Power (dBm)	Duty Factor (dB)	Total Power (dBm)	Limit (dBm)	Verdict
NVNT	802.11n(HT20)	2412	Ant 1	20.587	0	20.587	30	Pass
NVNT	802.11n(HT20)	2437	Ant 1	20.172	0	20.172	30	Pass
NVNT	802.11n(HT20)	2462	Ant 1	20.245	0	20.245	30	Pass

Power NVNT 802.11n(HT20) 2412MHz Ant1

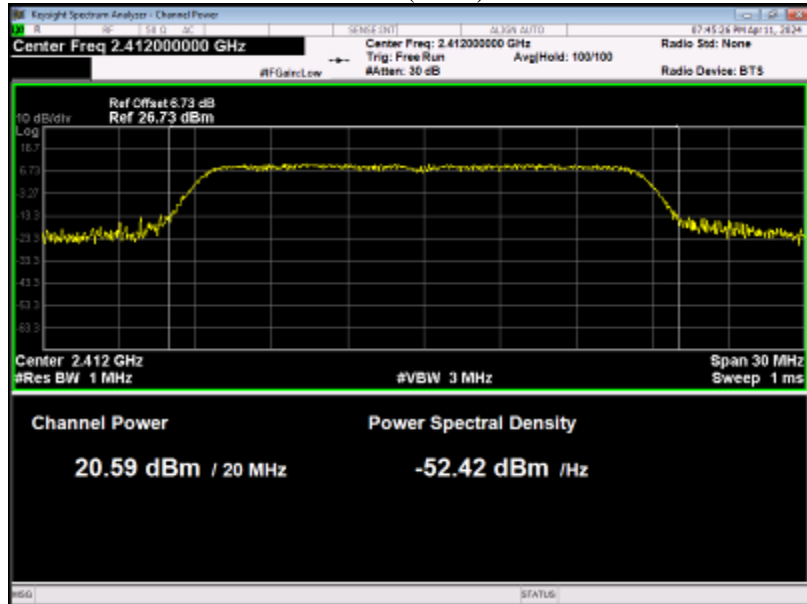

Power NVNT 802.11n(HT20) 2437MHz Ant1

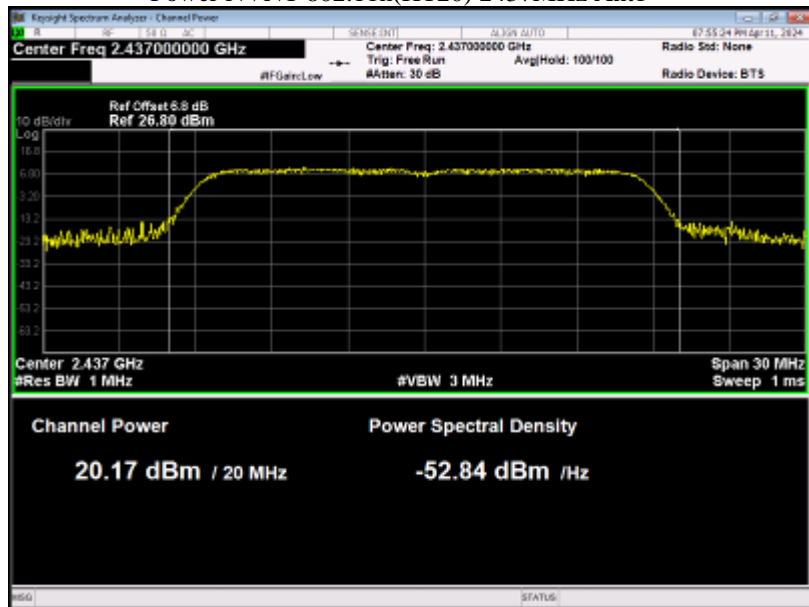

Power NVNT 802.11n(HT20) 2462MHz Ant1

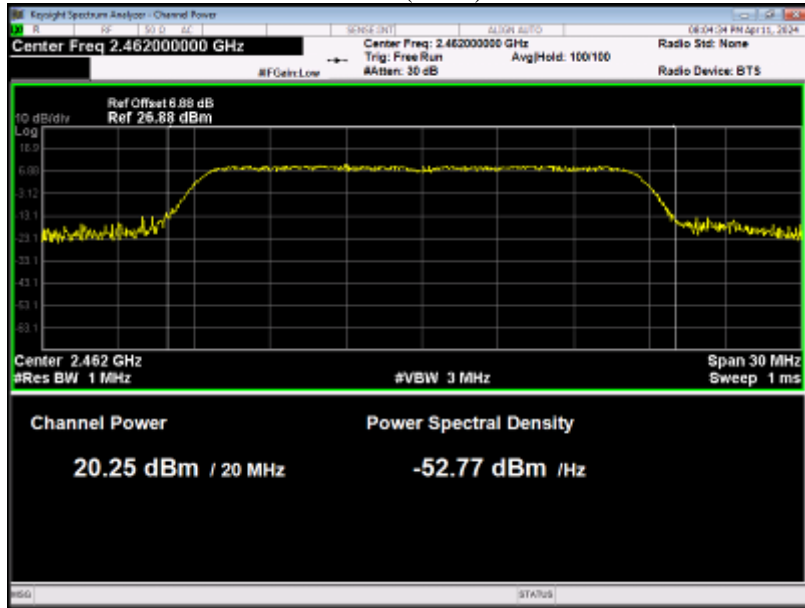

## 6. -6dB Bandwidth

### 6.1. Test equipment

Item	Equipment	Manufacturer	Model No.	Serial No.	Last Cal.	Cal. Interval
1	MXA Signal Analyzer	KEYSIGHT	N9020A	MY54510476	2023/05/19	1 Year

### 6.2. BLOCK DIAGRAM OF TEST SETUP

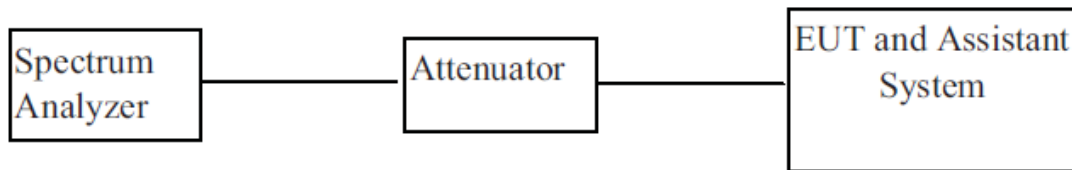

### 6.3. Limit

Systems using digital modulation techniques may operate in the 902 - 928 MHz, 2400 - 2483.5 MHz, and 5725 - 5850 MHz bands. The minimum 6 dB bandwidth shall be at least 500 kHz.

### 6.4. Test Procedure

1. Connect EUT RF output port to the Spectrum Analyzer through an RF attenuator
2. Set the EUT Work on the top, the middle and the bottom operation frequency individually.
3. Set SPA Centre Frequency = Operation Frequency, RBW= 100 KHz, VBW $\geq$ 3 $\times$ RBW.
4. Set SPA Trace 1 Max hold, then View.

Note: The EUT was tested according to KDB 558074 for compliance to FCC 47CFR 15.247 requirements.



### 6.5. Test result

Condition	Mode	Frequency (MHz)	Antenna	99% OBW (MHz)	-6 dB Bandwidth (MHz)	Limit -6 dB Bandwidth (MHz)	Verdict
NVNT	802.11b 1Mbps	2412	Ant 1	13.4259	9.4475	0.5	Pass
NVNT	802.11b 1Mbps	2437	Ant 1	13.150	9.1039	0.5	Pass
NVNT	802.11b 1Mbps	2462	Ant 1	13.4368	9.4604	0.5	Pass

OBW NVNT 802.11b 1Mbps 2412MHz Ant1

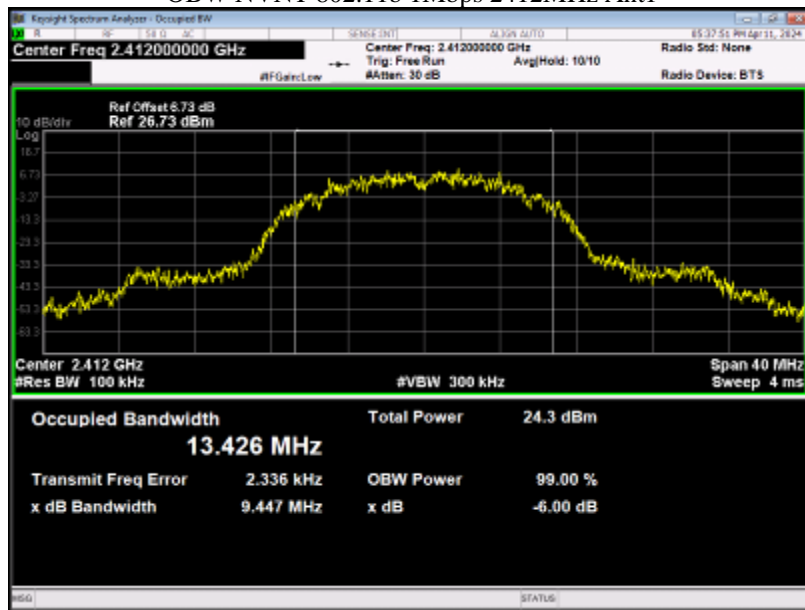

OBW NVNT 802.11b 1Mbps 2437MHz Ant1

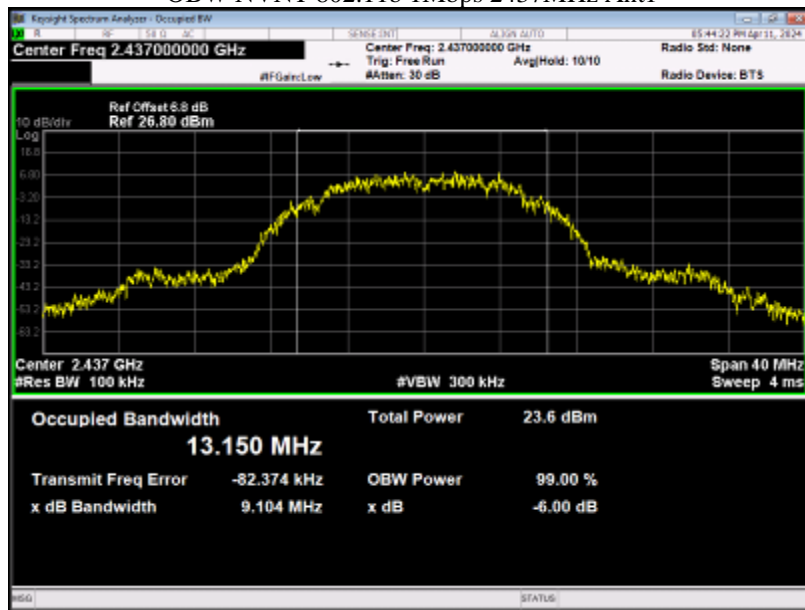

OBW NVNT 802.11b 1Mbps 2462MHz Ant1

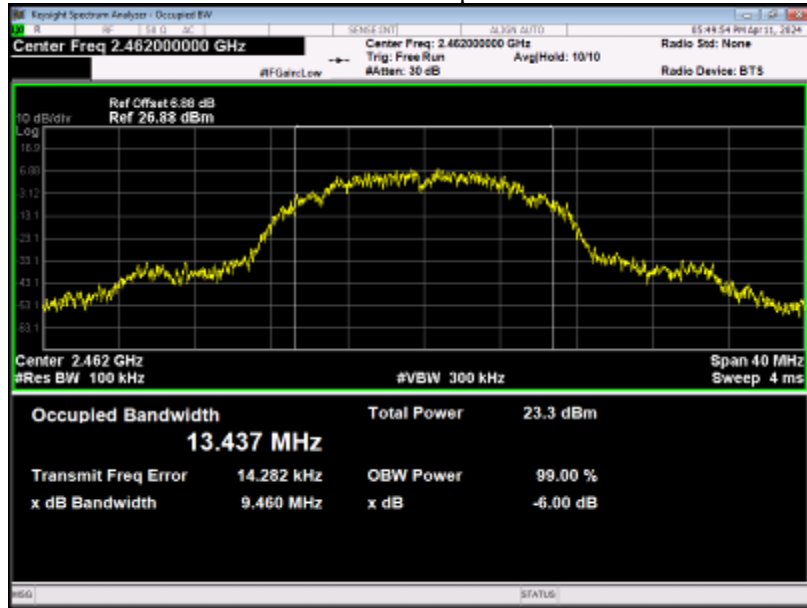

Condition	Mode	Frequency (MHz)	Antenna	99% OBW (MHz)	-6 dB Bandwidth (MHz)	Limit -6 dB Bandwidth (MHz)	Verdict
NVNT	802.11g 6Mbps	2412	Ant 1	16.3396	16.3898	0.5	Pass
NVNT	802.11g 6Mbps	2437	Ant 1	16.3502	16.45	0.5	Pass
NVNT	802.11g 6Mbps	2462	Ant 1	16.3633	16.4583	0.5	Pass

OBW NVNT 802.11g 6Mbps 2412MHz Ant1

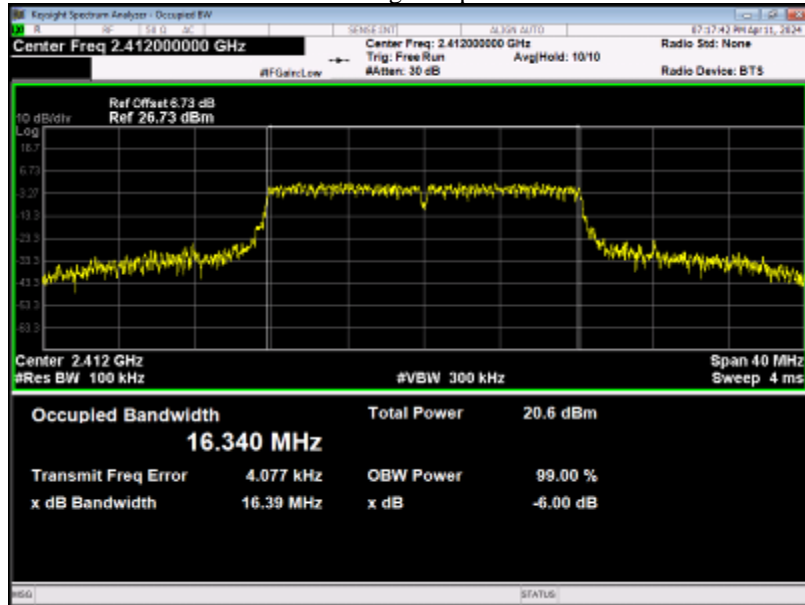

OBW NVNT 802.11g 6Mbps 2437MHz Ant1

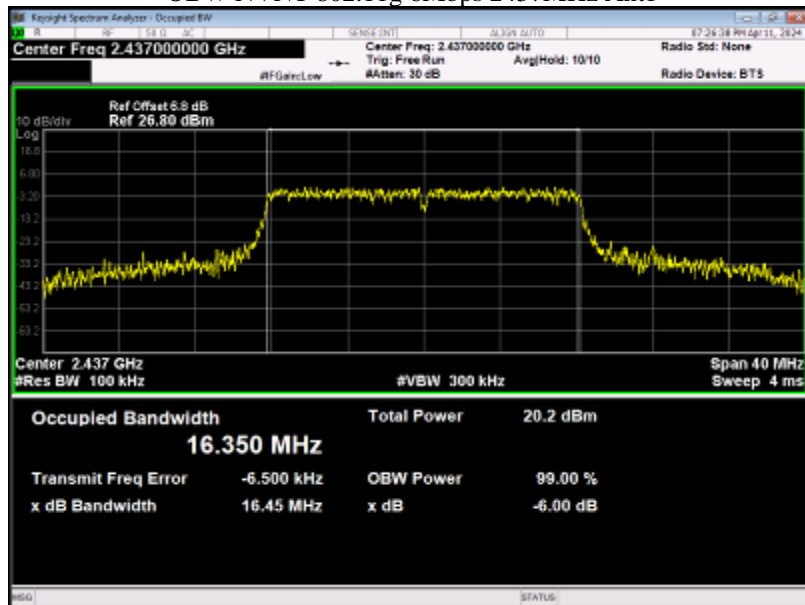

OBW NVNT 802.11g 6Mbps 2462MHz Ant1

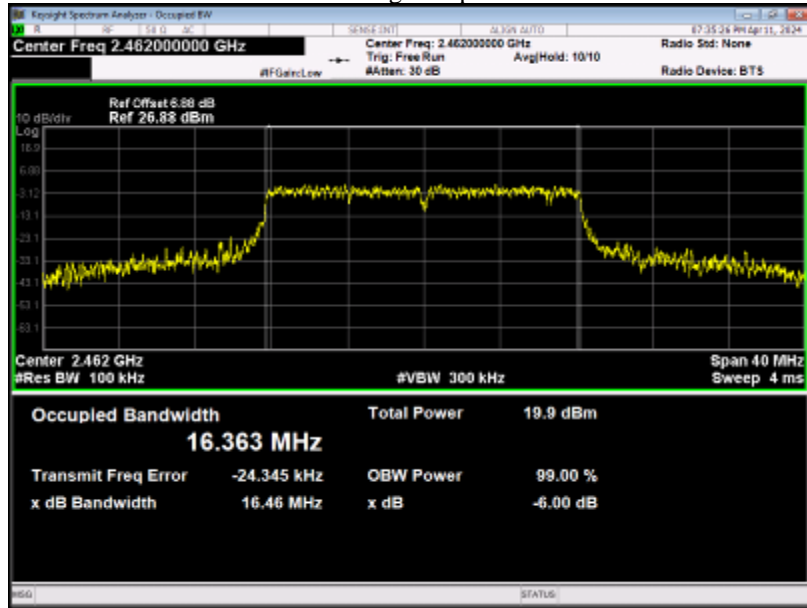

Condition	Mode	Frequency (MHz)	Antenna	99% OBW (MHz)	-6 dB Bandwidth (MHz)	Limit -6 dB Bandwidth (MHz)	Verdict
NVNT	802.11n(HT20)	2412	Ant 1	17.3178	17.1194	0.5	Pass
NVNT	802.11n(HT20)	2437	Ant 1	17.3052	16.8947	0.5	Pass
NVNT	802.11n(HT20)	2462	Ant 1	17.2654	17.1074	0.5	Pass

OBW NVNT 802.11n(HT20) 2412MHz Ant1

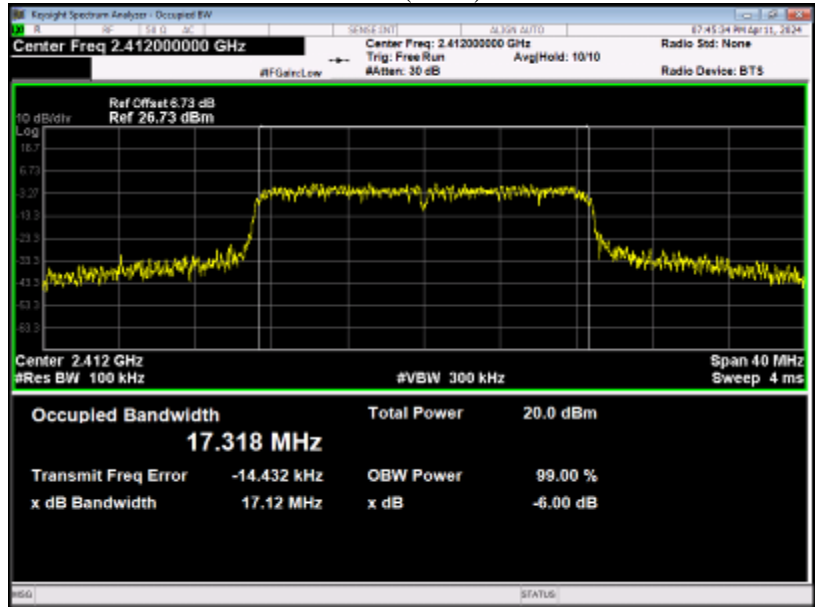

OBW NVNT 802.11n(HT20) 2437MHz Ant1

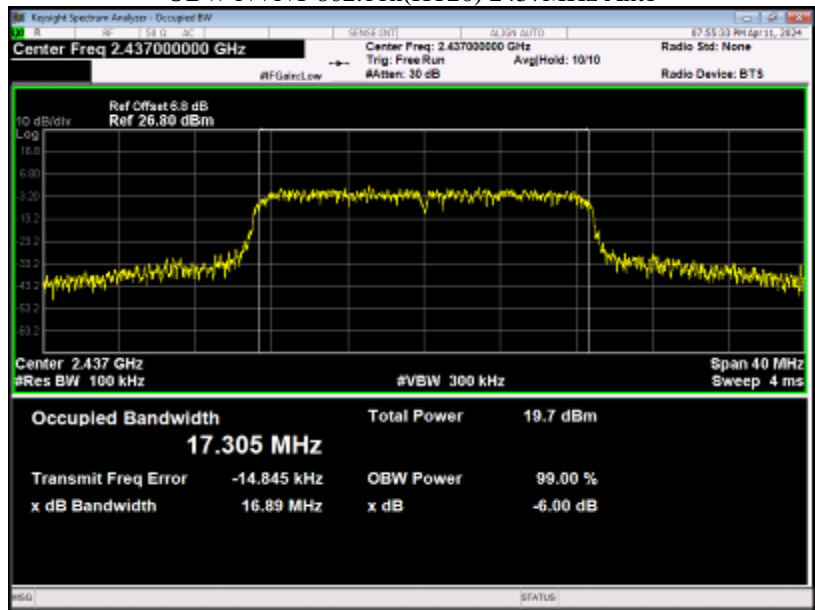

OBW NVNT 802.11n(HT20) 2462MHz Ant1

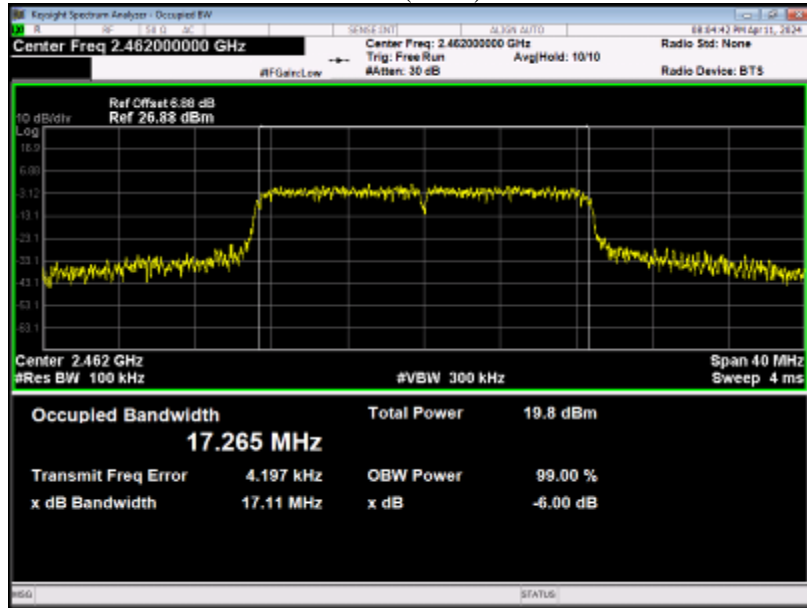

## 7. Band Edges Measurement

### 7.1. Test equipment

Item	Equipment	Manufacturer	Model No.	Serial No.	Last Cal.	Cal. Interval
1	MXA Signal Analyzer	KEYSIGHT	N9020A	MY54510476	2023/05/19	1 Year

### 7.2. BLOCK DIAGRAM OF TEST SETUP

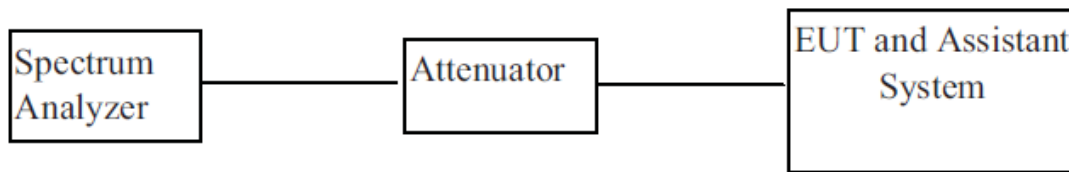

### 7.3. Limit

Below  $-30\text{dB}$  of the highest emission level of operating band (In 100 kHz Resolution Bandwidth)

### 7.4. Test Procedure

The transmitter output was connected to the spectrum analyzer via a low lose cable.

Set RBW of spectrum analyzer to 100 KHz and VBW of spectrum analyzer to 300 KHz with convenient frequency span including 100 KHz bandwidth from band edge.

Peak conducted output power measured within any 100 kHz outside the authorized frequency band shall be attenuated by at least 30dB relative to the maximum measured in-band peak PSD level.

The band edges was measured and recorded.

### 7.5. Test result

Condition	Mode	Frequency (MHz)	Antenna	Max Value (dBc)	Limit (dBc)	Verdict
NVNT	802.11b 1Mbps	2412	Ant 1	-60.545	-30	Pass
NVNT	802.11b 1Mbps	2462	Ant 1	-59.224	-30	Pass

Band Edge NVNT 802.11b 1Mbps 2412MHz Ant1 Ref



Band Edge NVNT 802.11b 1Mbps 2412MHz Ant1 Emission

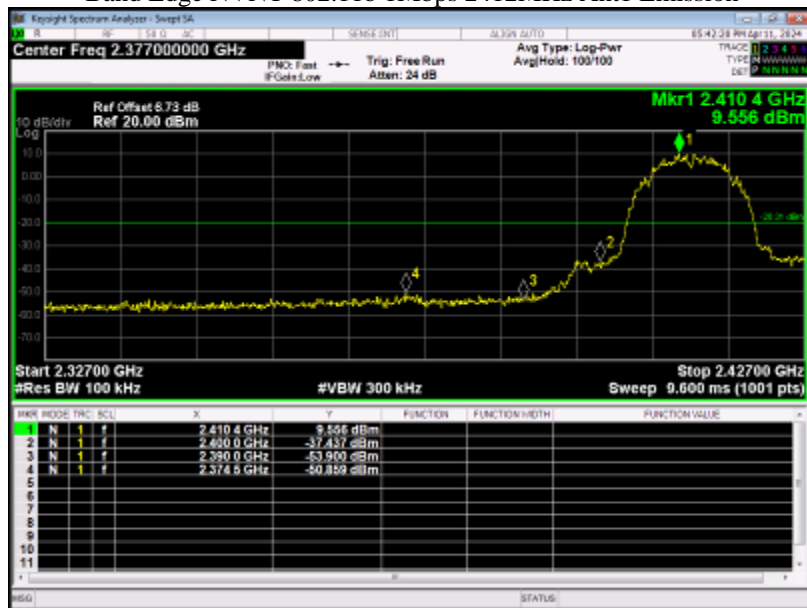



Band Edge NVNT 802.11b 1Mbps 2462MHz Ant1 Ref

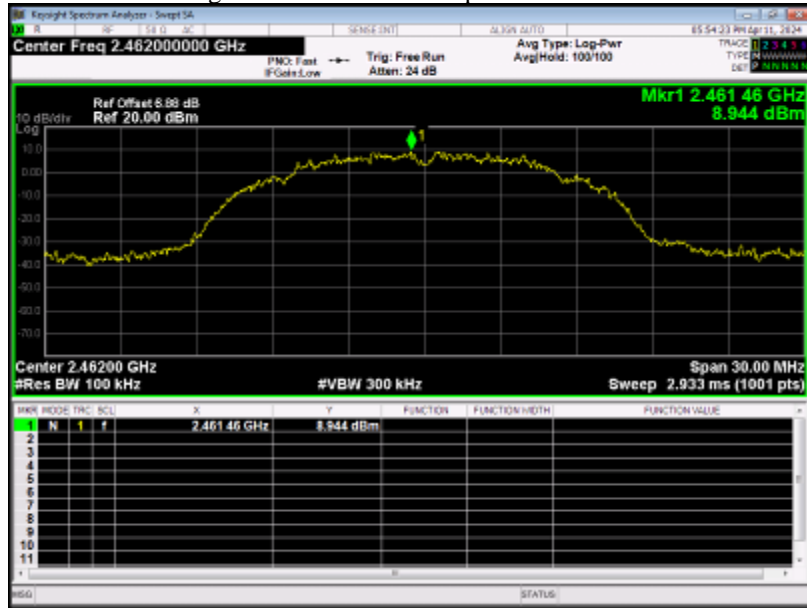

Band Edge NVNT 802.11b 1Mbps 2462MHz Ant1 Emission

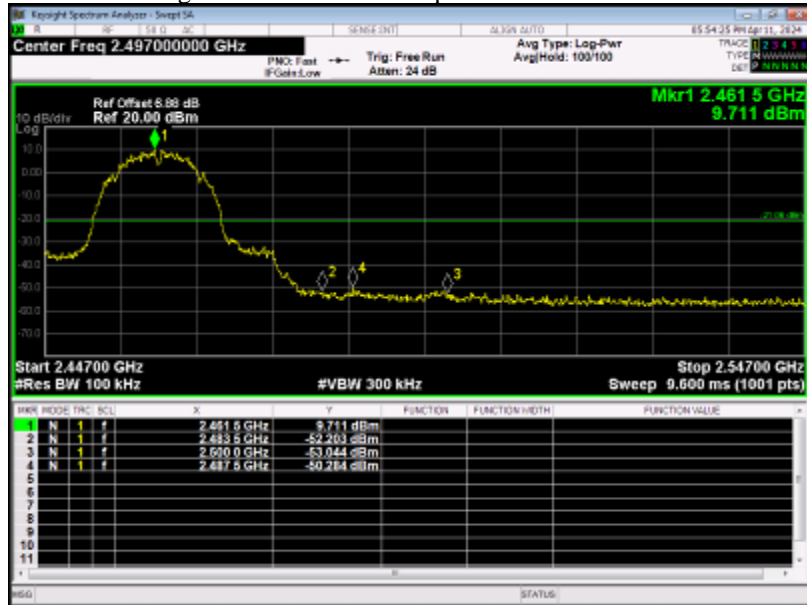

Condition	Mode	Frequency (MHz)	Antenna	Max Value (dBc)	Limit (dBc)	Verdict
NVNT	802.11g 6Mbps	2412	Ant 1	-44.483	-30	Pass
NVNT	802.11g 6Mbps	2462	Ant 1	-41.632	-30	Pass

Band Edge NVNT 802.11g 6Mbps 2412MHz Ant1 Ref

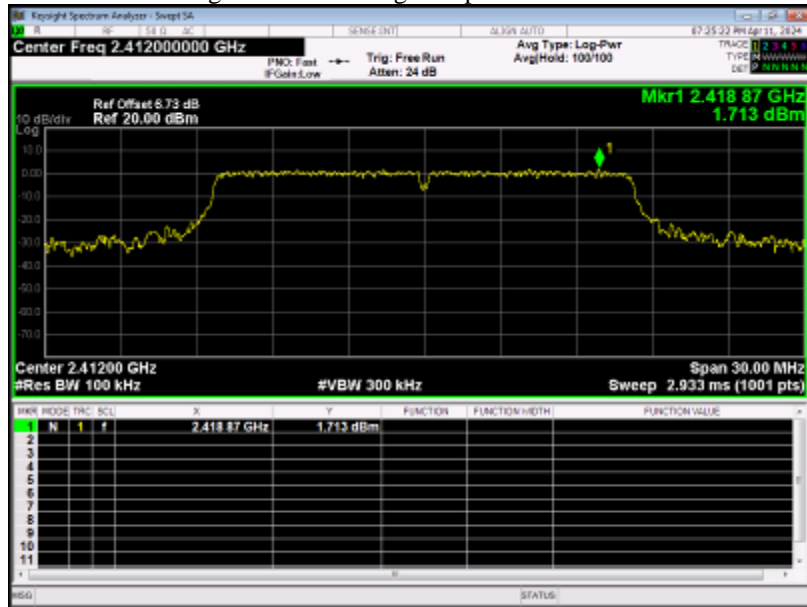

Band Edge NVNT 802.11g 6Mbps 2412MHz Ant1 Emission

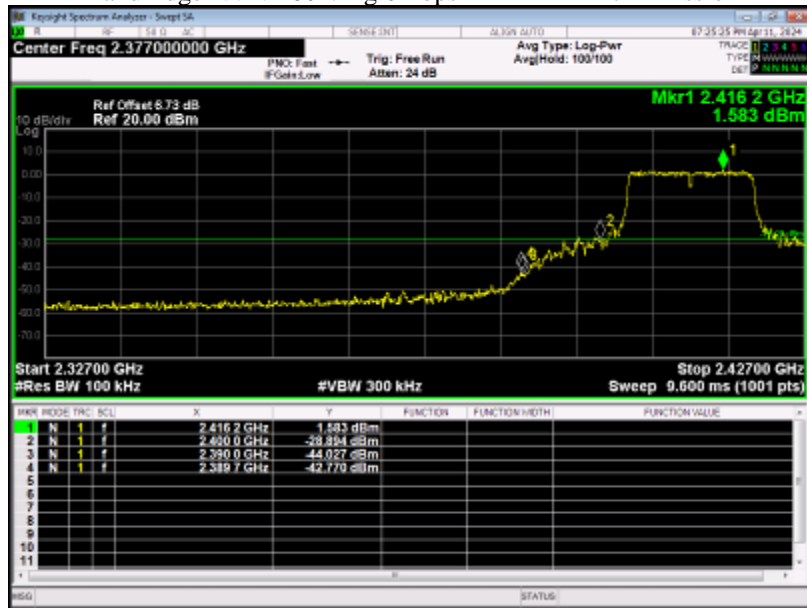

Band Edge NVNT 802.11g 6Mbps 2462MHz Ant1 Ref

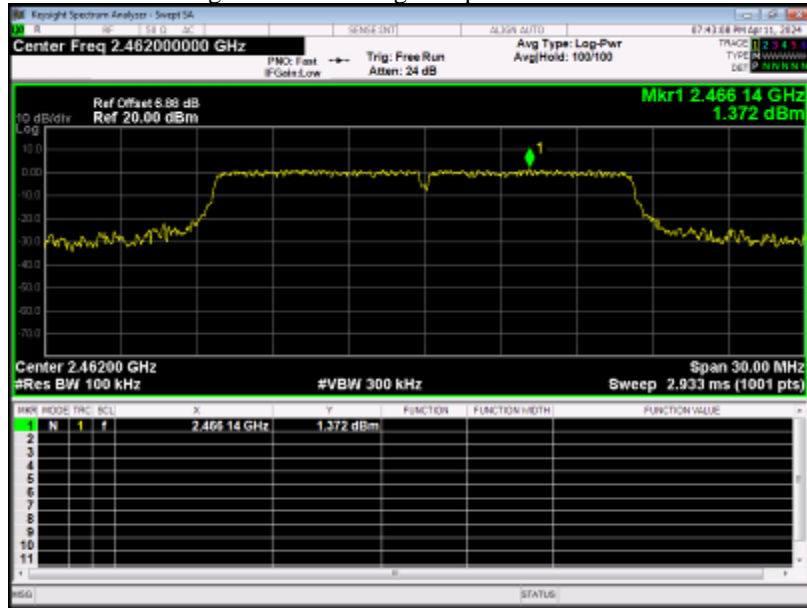

Band Edge NVNT 802.11g 6Mbps 2462MHz Ant1 Emission



Condition	Mode	Frequency (MHz)	Antenna	Max Value (dBc)	Limit (dBc)	Verdict
NVNT	802.11n(HT20)	2412	Ant 1	-42.922	-30	Pass
NVNT	802.11n(HT20)	2462	Ant 1	-39.017	-30	Pass

Band Edge NVNT 802.11n(HT20) 2412MHz Ant1 Ref

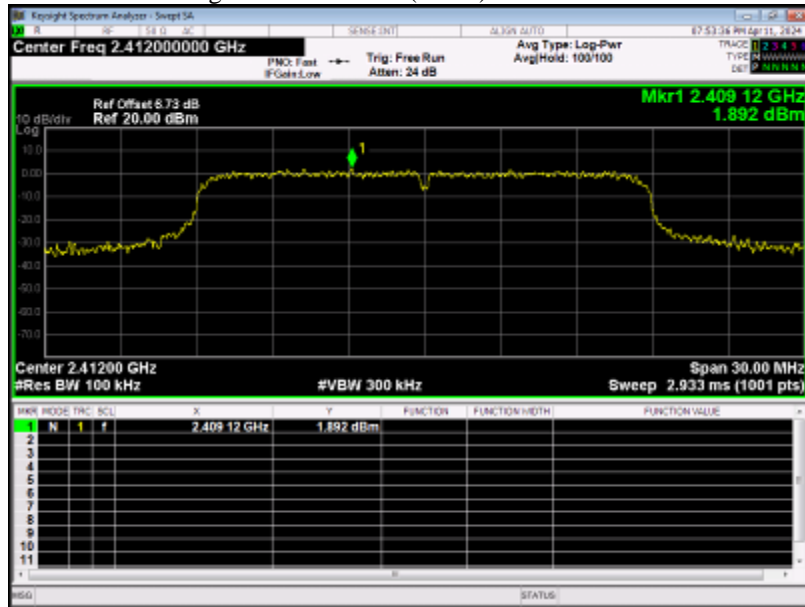

Band Edge NVNT 802.11n(HT20) 2412MHz Ant1 Emission



Band Edge NVNT 802.11n(HT20) 2462MHz Ant1 Ref

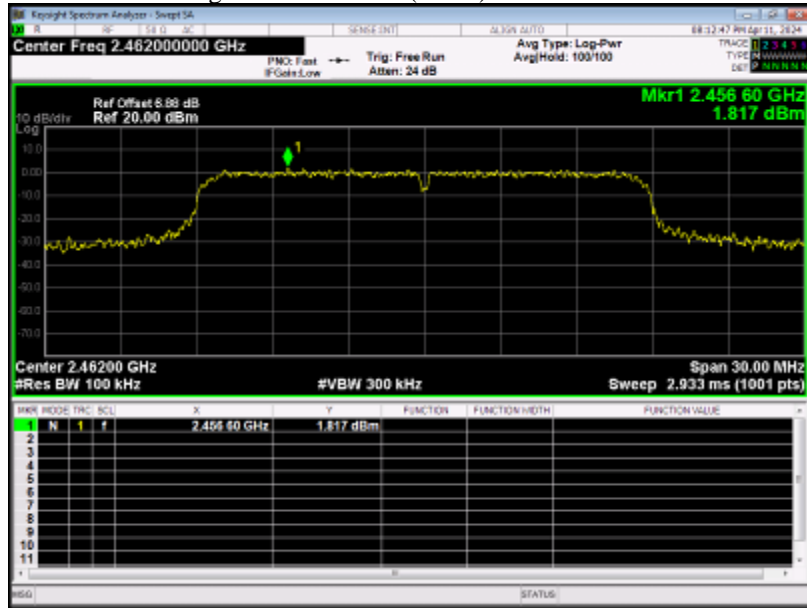

Band Edge NVNT 802.11n(HT20) 2462MHz Ant1 Emission



## 8. Conducted Spurious Emission

### 8.1. Test equipment

Item	Equipment	Manufacturer	Model No.	Serial No.	Last Cal.	Cal. Interval
1	MXA Signal Analyzer	KEYSIGHT	N9020A	MY54510476	2023/05/19	1 Year

### 8.2. BLOCK DIAGRAM OF TEST SETUP

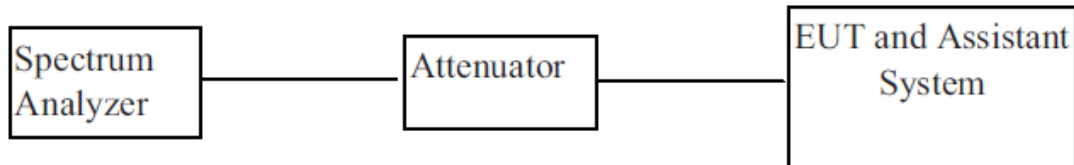

### 8.3. Limit

In any 100 KHz Bandwidth Outside the frequency band in which the spread spectrum intentional radiator is operating, the radio frequency power that is produce by the intentional radiator shall be at least 20 dB below that in 100KHz bandwidth within the band that contains the highest level of the desired power.

In addition, radiation emissions which fall in the restricted bands, as defined in §15.205(a), must also comply with the radiated emission limits specified in§15.209(a)

### 8.4. Test Procedure

1. Connect EUT RF output port to the Spectrum Analyzer through an RF attenuator
- 2, Set the EUT Work on the top, the middle and the bottom operation frequency individually.
3. Set SPA Trace 1 Max hold, then View.

Note: The EUT was tested according to KDB 558074 for compliance to FCC 47CFR 15.247 requirements. Owing to satisfy the requirements of the number of measurement points, we set the RBW=1MHz, VBW > RBW, scan up through 10th harmonic, and consider the tested results as the worst case, if the tested results conform to the requirement, we can deem that the real tested results(set the RBW=100KHz, VBW > RBW) are conform to the requirement.

### 8.5. Test result

Condition	Mode	Frequency (MHz)	Antenna	Max Value (dBc)	Limit (dBc)	Verdict
NVNT	802.11b 1Mbps	2412	Ant 1	-50.674	-30	Pass
NVNT	802.11b 1Mbps	2437	Ant 1	-51.116	-30	Pass
NVNT	802.11b 1Mbps	2462	Ant 1	-50.333	-30	Pass

Tx. Spurious NVNT 802.11b 1Mbps 2412MHz Ant1 Ref

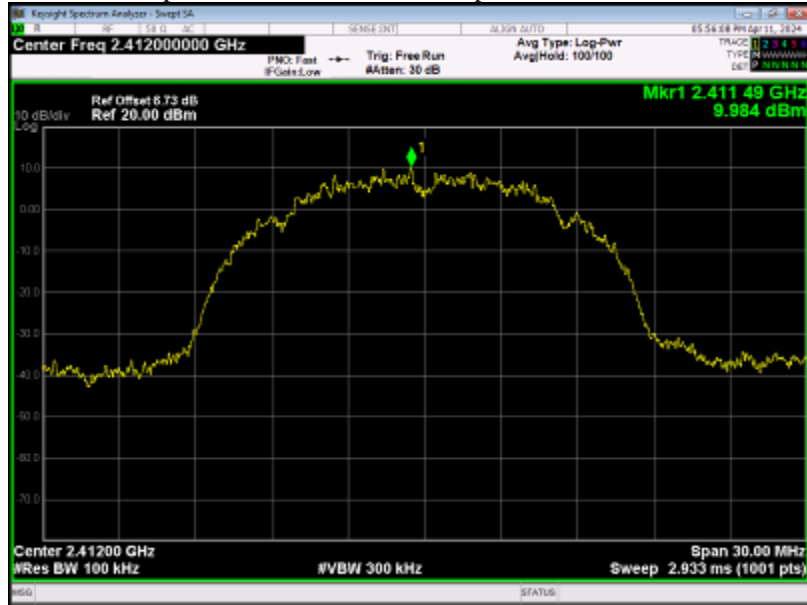

Tx. Spurious NVNT 802.11b 1Mbps 2412MHz Ant1 Emission

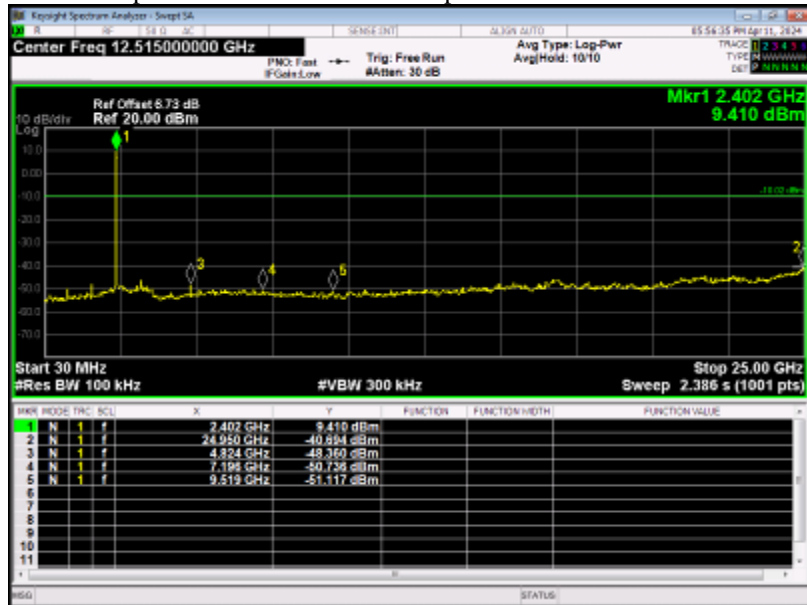

Tx. Spurious NVNT 802.11b 1Mbps 2437MHz Ant1 Ref

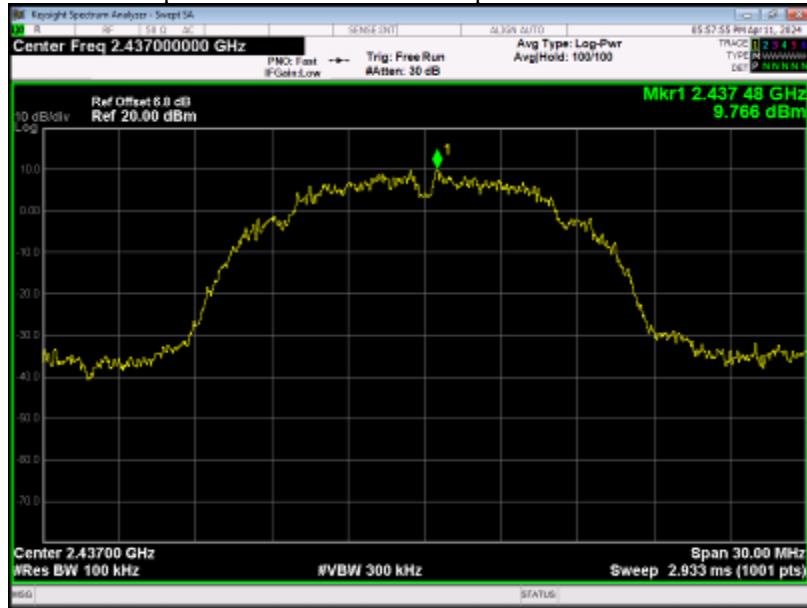

Tx. Spurious NVNT 802.11b 1Mbps 2437MHz Ant1 Emission

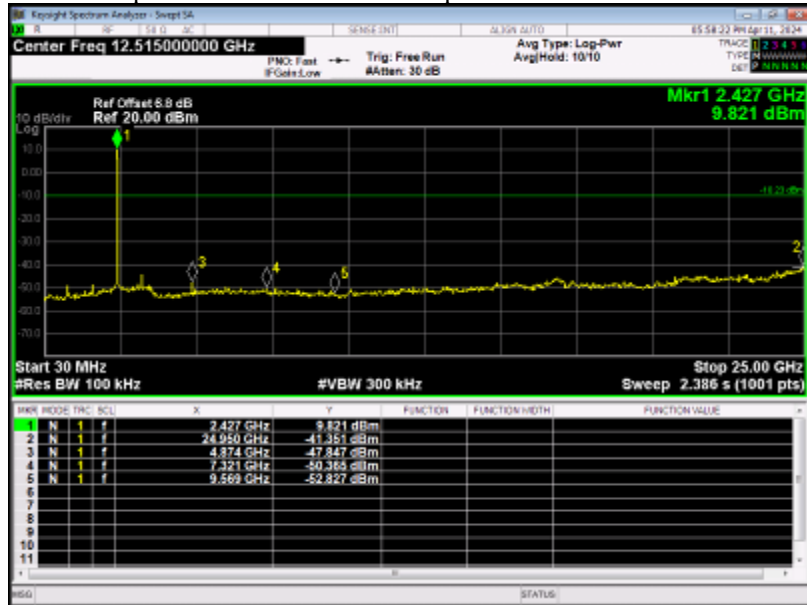



Tx. Spurious NVNT 802.11b 1Mbps 2462MHz Ant1 Ref

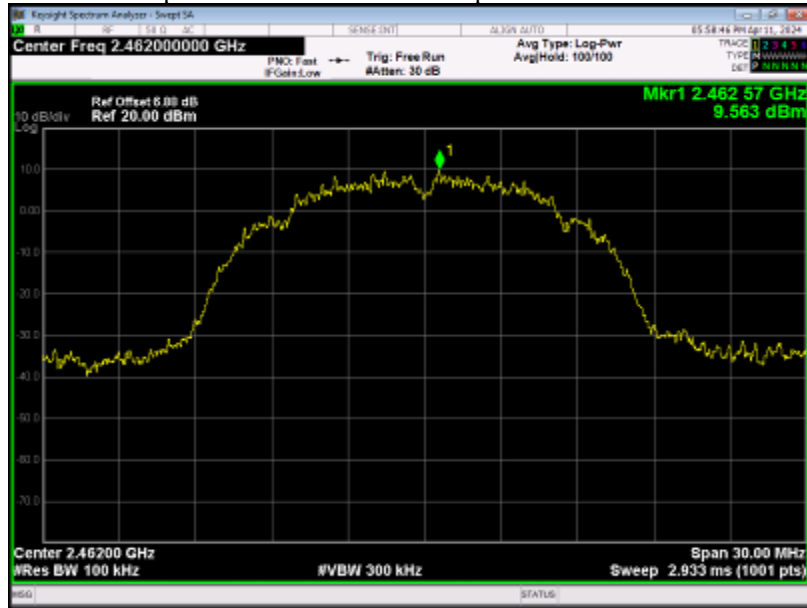

Tx. Spurious NVNT 802.11b 1Mbps 2462MHz Ant1 Emission

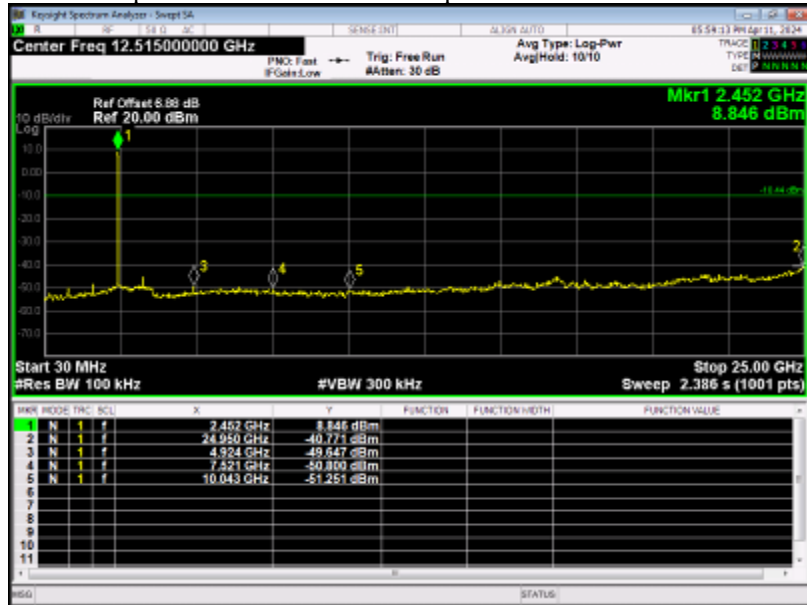

Condition	Mode	Frequency (MHz)	Antenna	Max Value (dBc)	Limit (dBc)	Verdict
NVNT	802.11g 6Mbps	2412	Ant 1	-42.856	-30	Pass
NVNT	802.11g 6Mbps	2437	Ant 1	-42.544	-30	Pass
NVNT	802.11g 6Mbps	2462	Ant 1	-42.311	-30	Pass

Tx. Spurious NVNT 802.11g 6Mbps 2412MHz Ant1 Ref



Tx. Spurious NVNT 802.11g 6Mbps 2412MHz Ant1 Emission

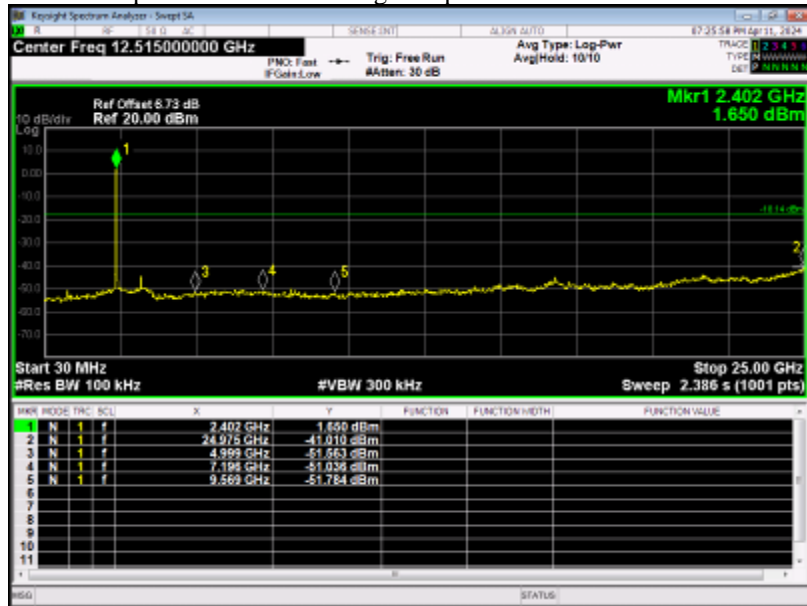

Tx. Spurious NVNT 802.11g 6Mbps 2437MHz Ant1 Ref



Tx. Spurious NVNT 802.11g 6Mbps 2437MHz Ant1 Emission

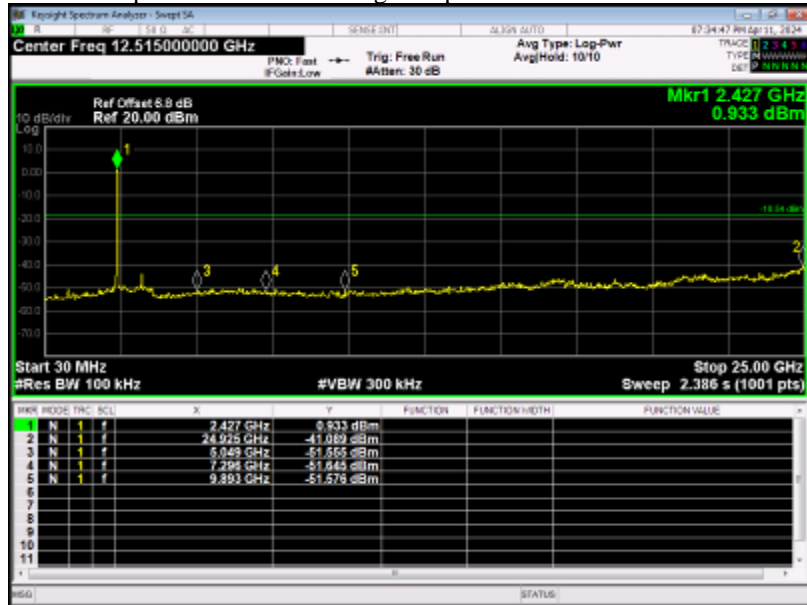

Tx. Spurious NVNT 802.11g 6Mbps 2462MHz Ant1 Ref

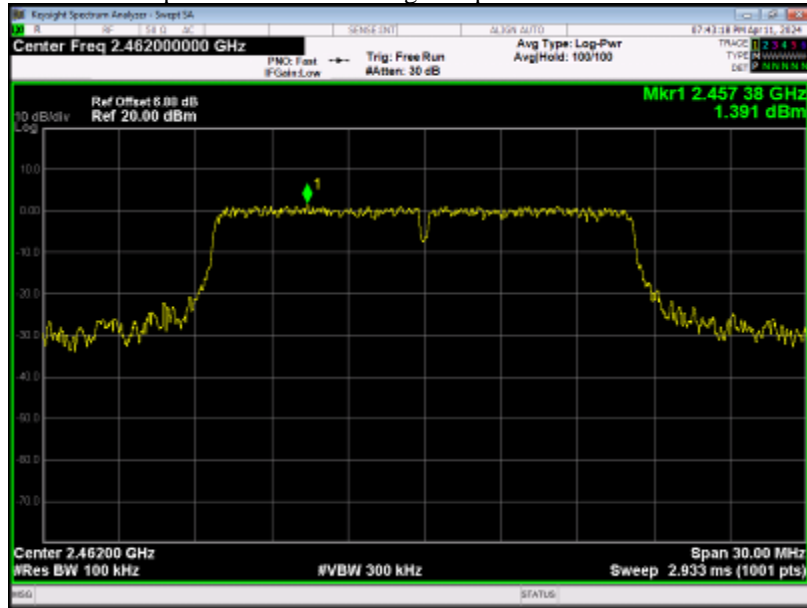

Tx. Spurious NVNT 802.11g 6Mbps 2462MHz Ant1 Emission

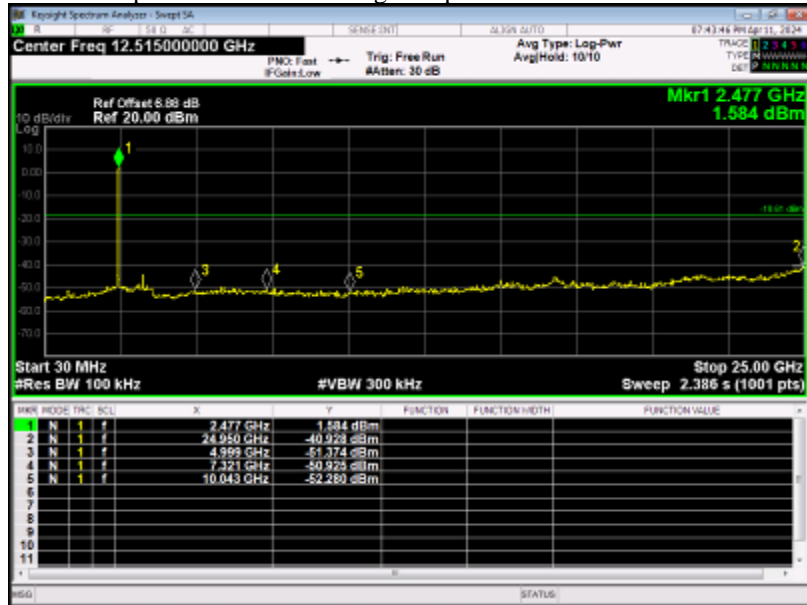

Condition	Mode	Frequency (MHz)	Antenna	Max Value (dBc)	Limit (dBc)	Verdict
NVNT	802.11n(HT20)	2412	Ant 1	-43.547	-30	Pass
NVNT	802.11n(HT20)	2437	Ant 1	-43.005	-30	Pass
NVNT	802.11n(HT20)	2462	Ant 1	-41.779	-30	Pass

Tx. Spurious NVNT 802.11n(HT20) 2412MHz Ant1 Ref

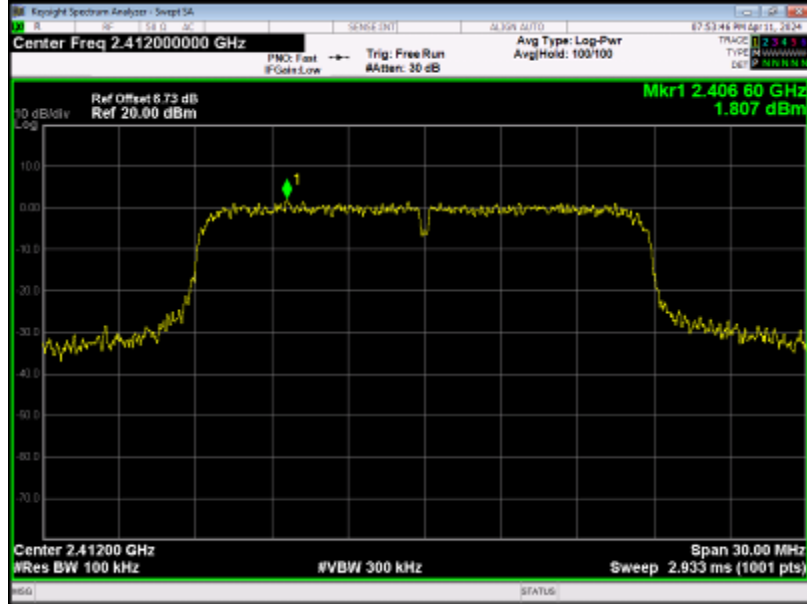

Tx. Spurious NVNT 802.11n(HT20) 2412MHz Ant1 Emission

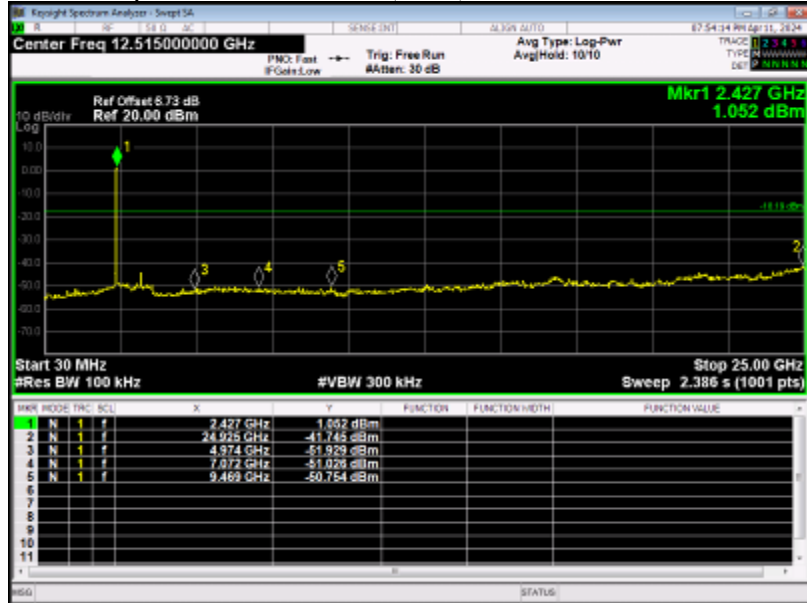

Tx. Spurious NVNT 802.11n(HT20) 2437MHz Ant1 Ref

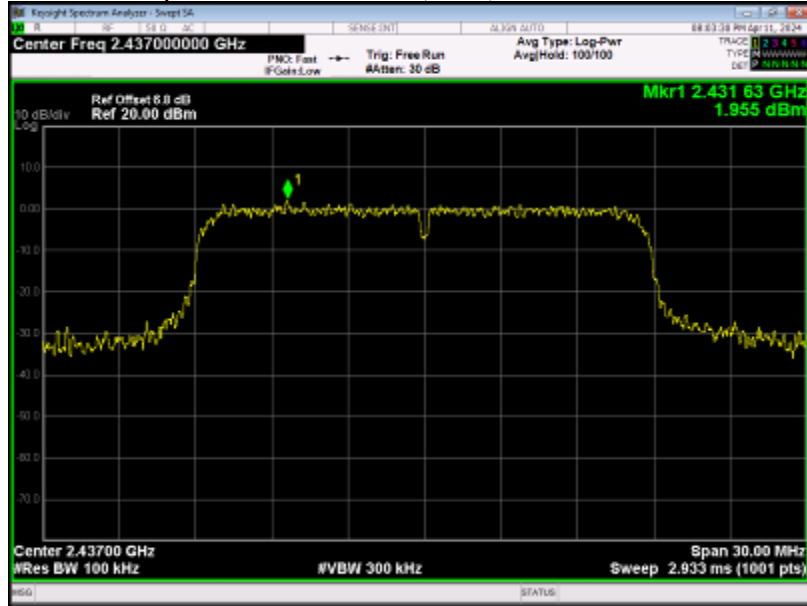

Tx. Spurious NVNT 802.11n(HT20) 2437MHz Ant1 Emission

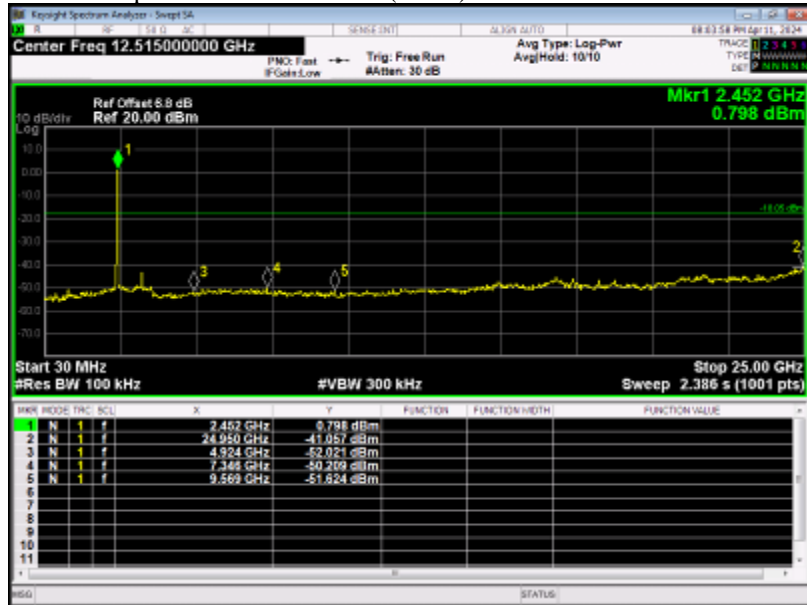

Tx. Spurious NVNT 802.11n(HT20) 2462MHz Ant1 Ref

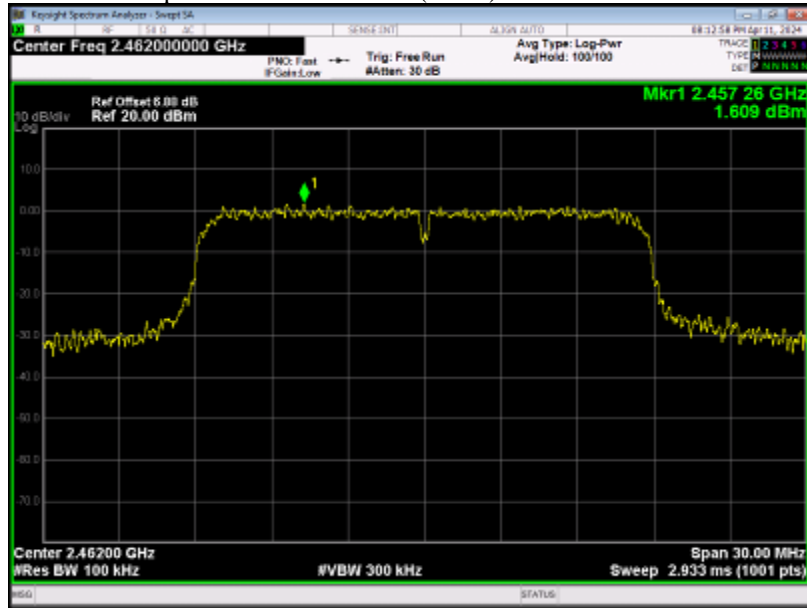

Tx. Spurious NVNT 802.11n(HT20) 2462MHz Ant1 Emission

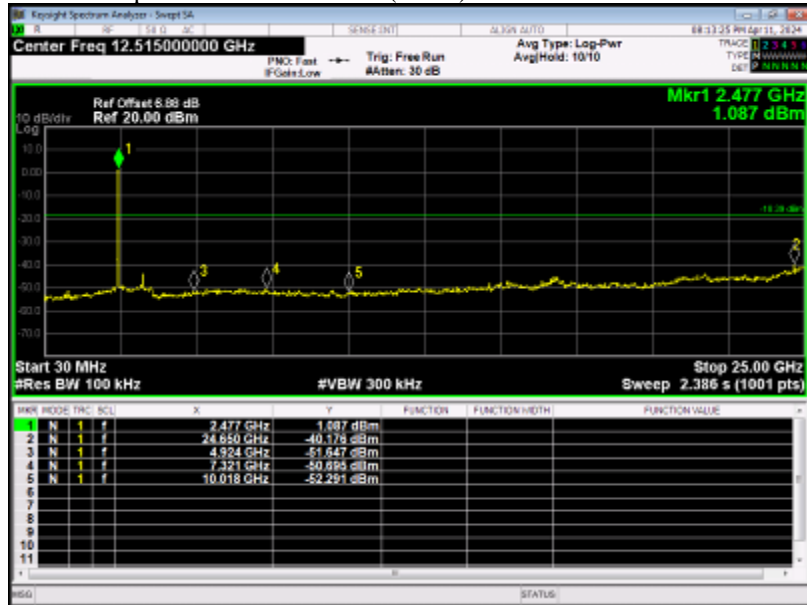

## 9. Conducted Output Power Spectral Density

### 9.1. Test equipment

Item	Equipment	Manufacturer	Model No.	Serial No.	Last Cal.	Cal. Interval
1	MXA Signal Analyzer	KEYSIGHT	N9020A	MY54510476	2023/05/19	1 Year

### 9.2. Block diagram of test setup

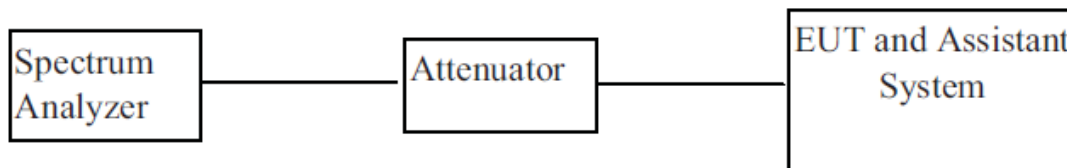

### 9.3. Limit

For digitally modulated systems, the power spectral density conducted from the intentional radiator to the antenna shall not be greater than 8 dBm in any 3 kHz band during any time interval of continuous transmission.

### 9.4. Test Procedure

- (1). Connect EUT RF output port to the Spectrum Analyzer through an RF attenuator
- (2). Set the EUT Work on the top, the middle and the bottom operation frequency individually.
- (3). Set SPA Trace 1 Max hold, then View.



### 9.5. Test result

Condition	Mode	Frequency (MHz)	Antenna	Max PSD (dBm/3kHz)	Limit (dBm/3kHz)	Verdict
NVNT	802.11b 1Mbps	2412	Ant 1	-6.243	8	Pass
NVNT	802.11b 1Mbps	2437	Ant 1	-6.654	8	Pass
NVNT	802.11b 1Mbps	2462	Ant 1	-6.401	8	Pass

PSD NVNT 802.11b 1Mbps 2412MHz Ant1

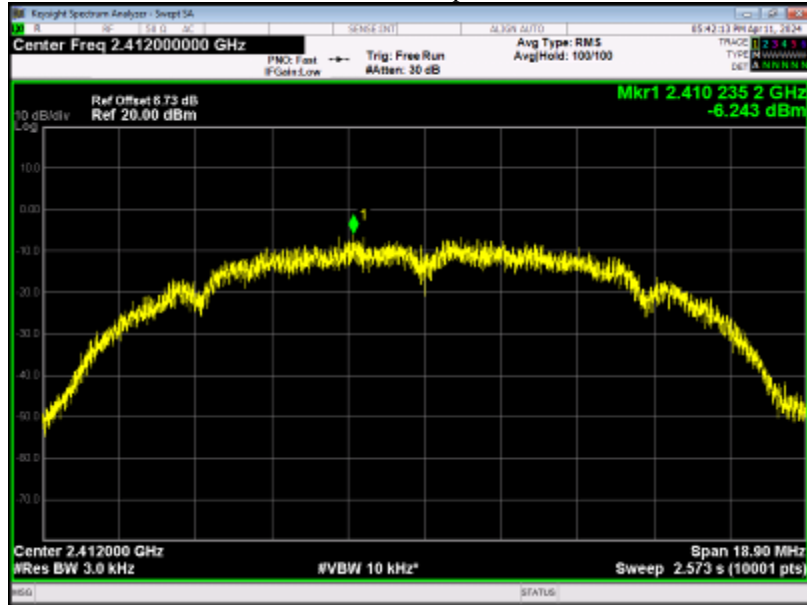

PSD NVNT 802.11b 1Mbps 2437MHz Ant1

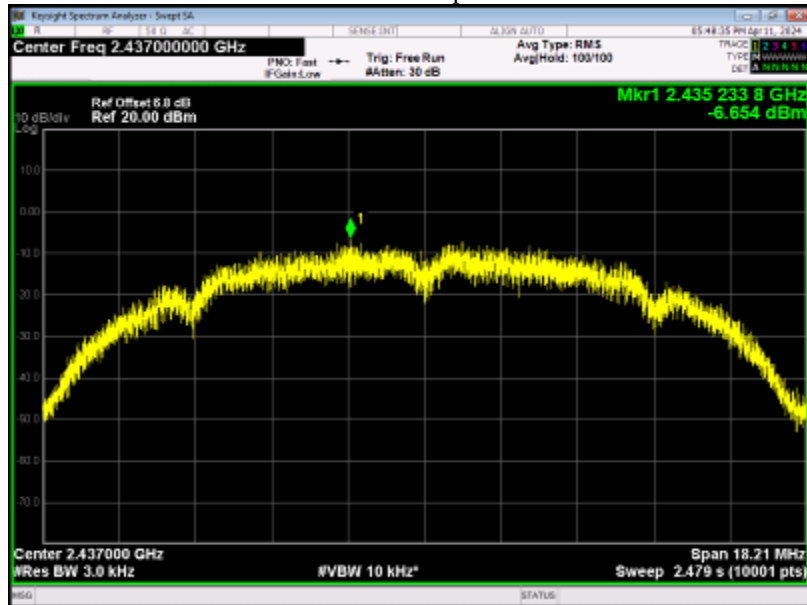

PSD NVNT 802.11b 1Mbps 2462MHz Ant1

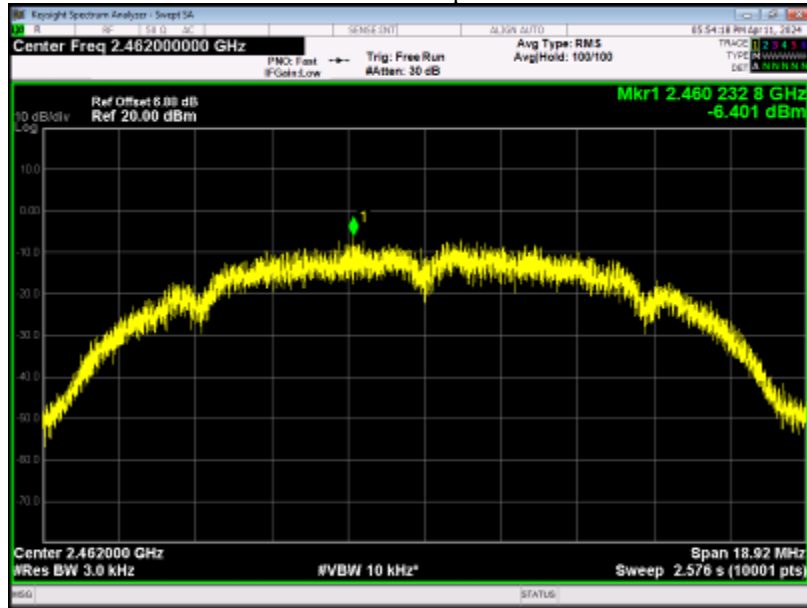

Condition	Mode	Frequency (MHz)	Antenna	Max PSD (dBm/3kHz)	Limit (dBm/3kHz)	Verdict
NVNT	802.11g 6Mbps	2412	Ant 1	-14.710	8	Pass
NVNT	802.11g 6Mbps	2437	Ant 1	-15.327	8	Pass
NVNT	802.11g 6Mbps	2462	Ant 1	-15.419	8	Pass

PSD NVNT 802.11g 6Mbps 2412MHz Ant1

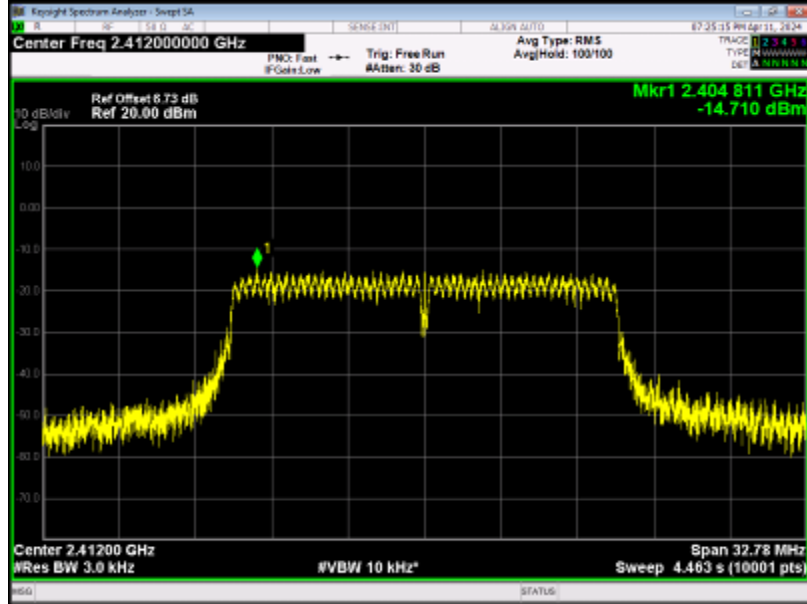

PSD NVNT 802.11g 6Mbps 2437MHz Ant1

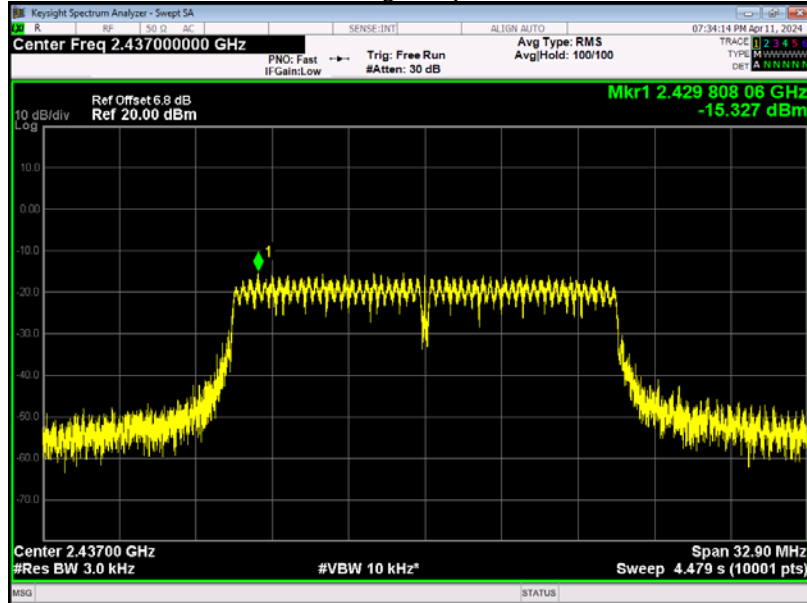

PSD NVNT 802.11g 6Mbps 2462MHz Ant1

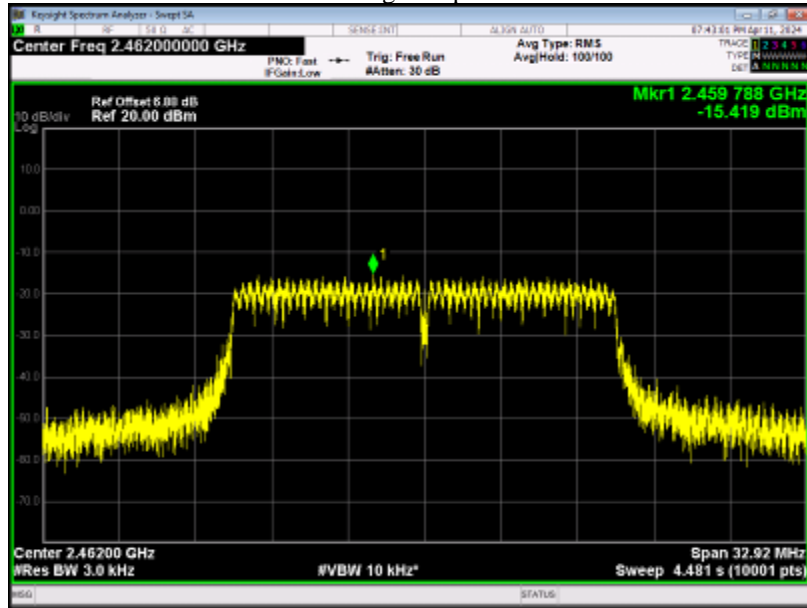

Condition	Mode	Frequency (MHz)	Antenna	Max PSD (dBm/3kHz)	Limit (dBm/3kHz)	Verdict
NVNT	802.11n(HT20)	2412	Ant 1	-14.794	8	Pass
NVNT	802.11n(HT20)	2437	Ant 1	-14.669	8	Pass
NVNT	802.11n(HT20)	2462	Ant 1	-14.615	8	Pass

PSD NVNT 802.11n(HT20) 2412MHz Ant1

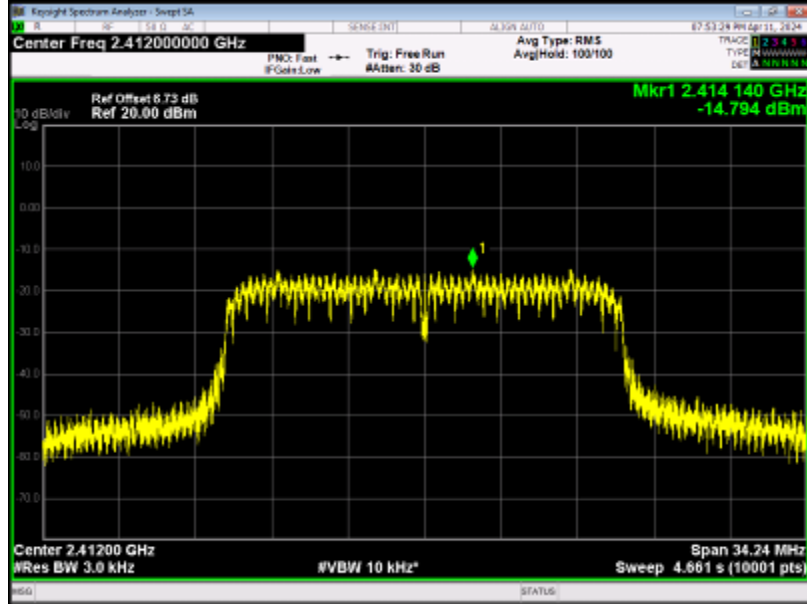

PSD NVNT 802.11n(HT20) 2437MHz Ant1

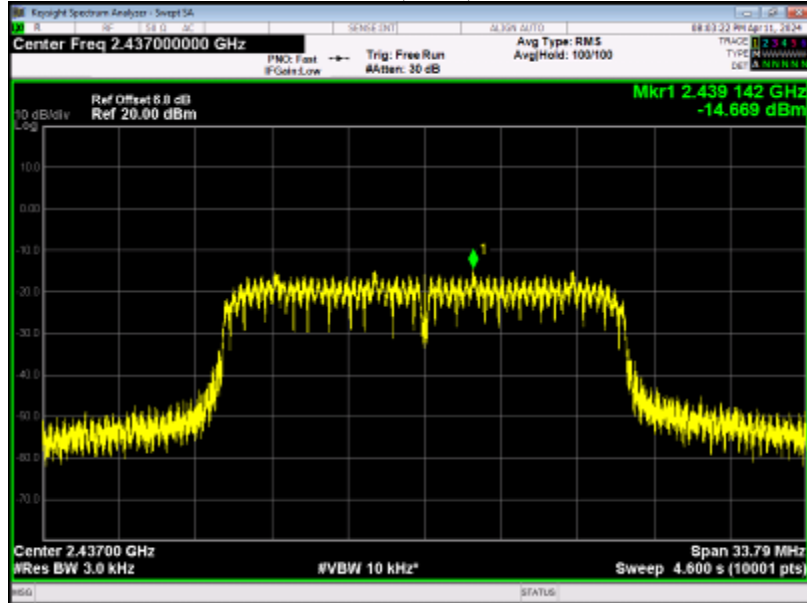

PSD NVNT 802.11n(HT20) 2462MHz Ant1

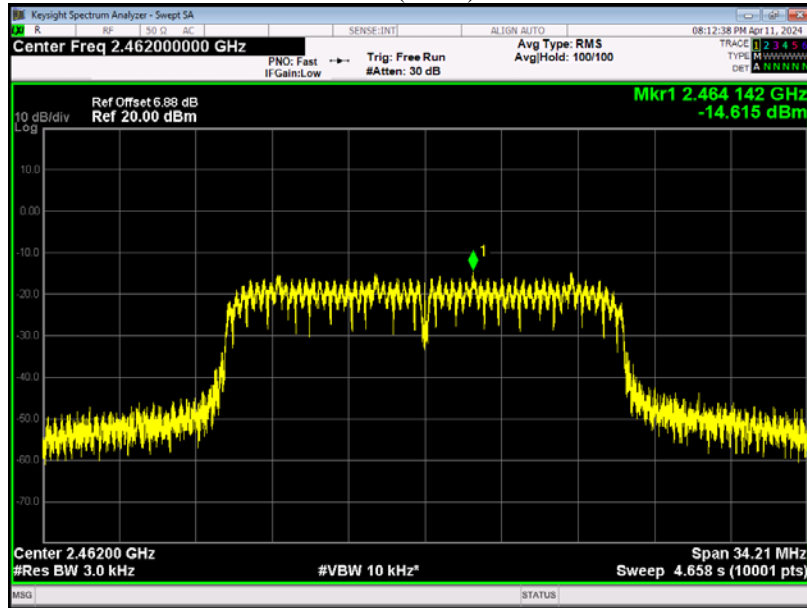

## **10. Antenna Requirement**

### **10.1. Standard requirement**

15.203 requirement: For intentional device, according to 15.203: an intentional radiator shall be designed to ensure that no antenna other than that furnished by the responsible party shall be used with the device.

15.247(c) (1)(i) requirement: (i) Systems operating in the 2400-2483.5 MHz band that is used exclusively for fixed. Point-to-point operations may employ transmitting antennas with directional gain greater than 6dBi provided the maximum conducted output power of the intentional radiator is reduced by 1 dB for every 3 dB that the directional gain of the antenna exceeds 6dBi.

### **10.2. EUT Antenna**

The antenna is Integral Antenna and no consideration of replacement. Antenna gain is Maximum 0.00dBi from 2.4GHz to 2.5GHz.

## 11. Test setup photograph

### 11.1. Photos of power line conducted emission test



### 11.2. Photos of radiated emission test

30MHz – 1GHz





Above 1GHz



## 12. Photos of the EUT







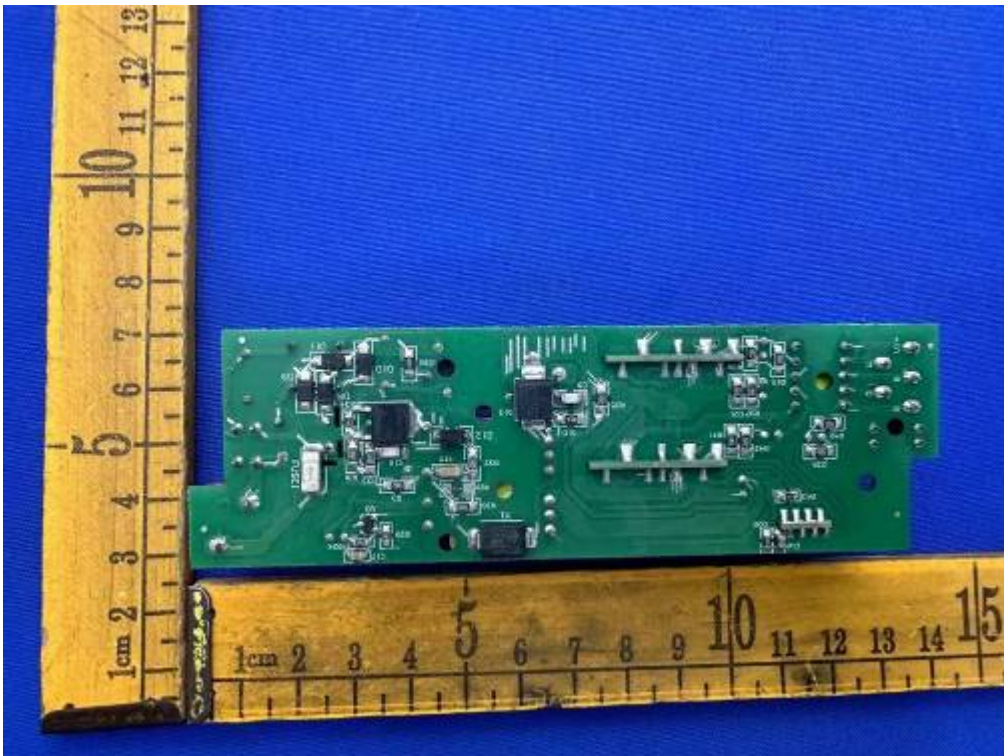
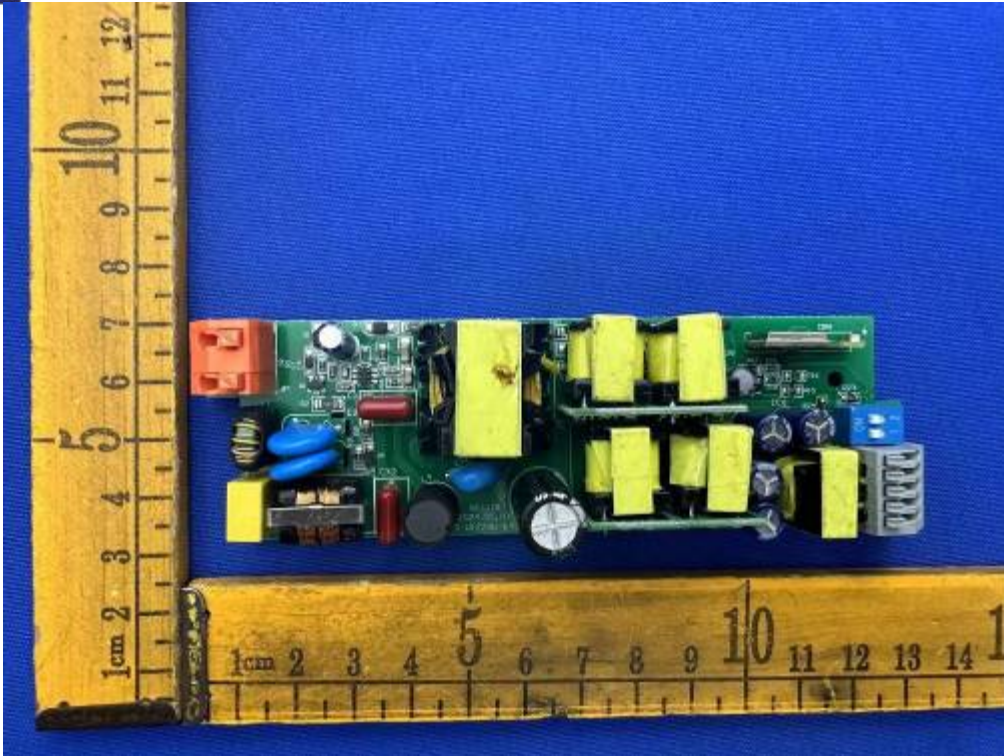

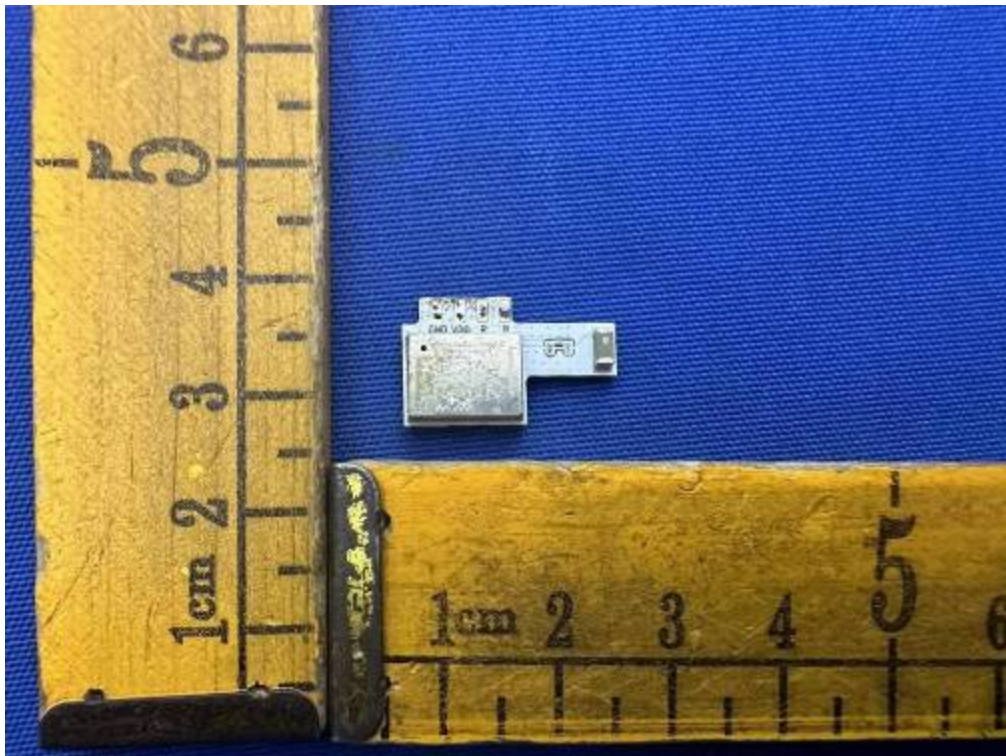
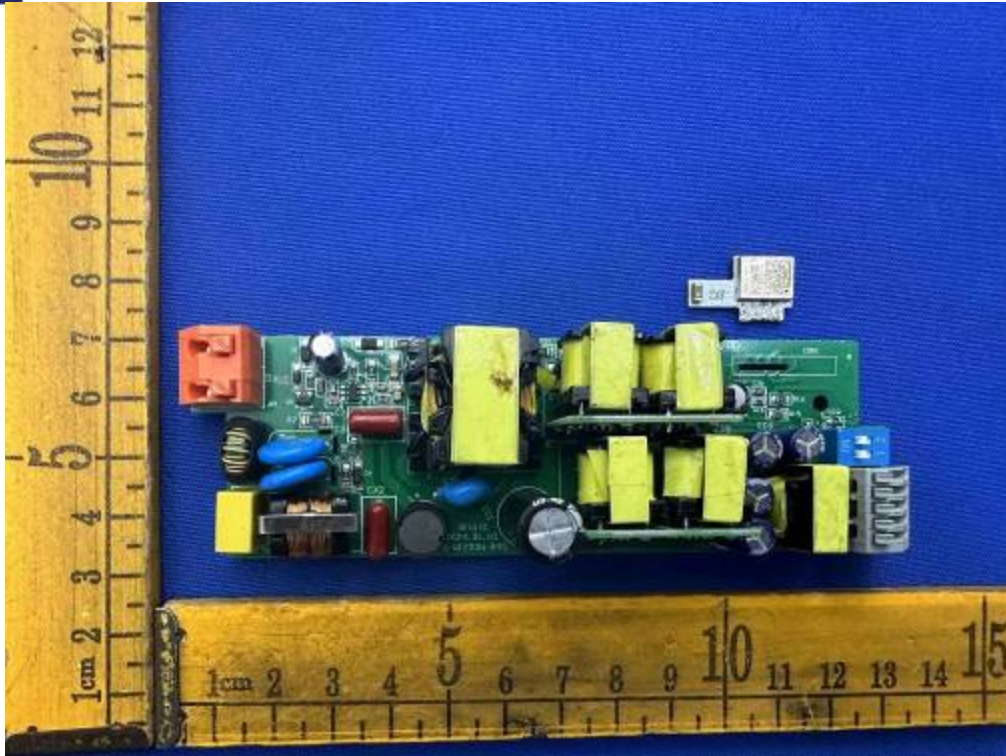

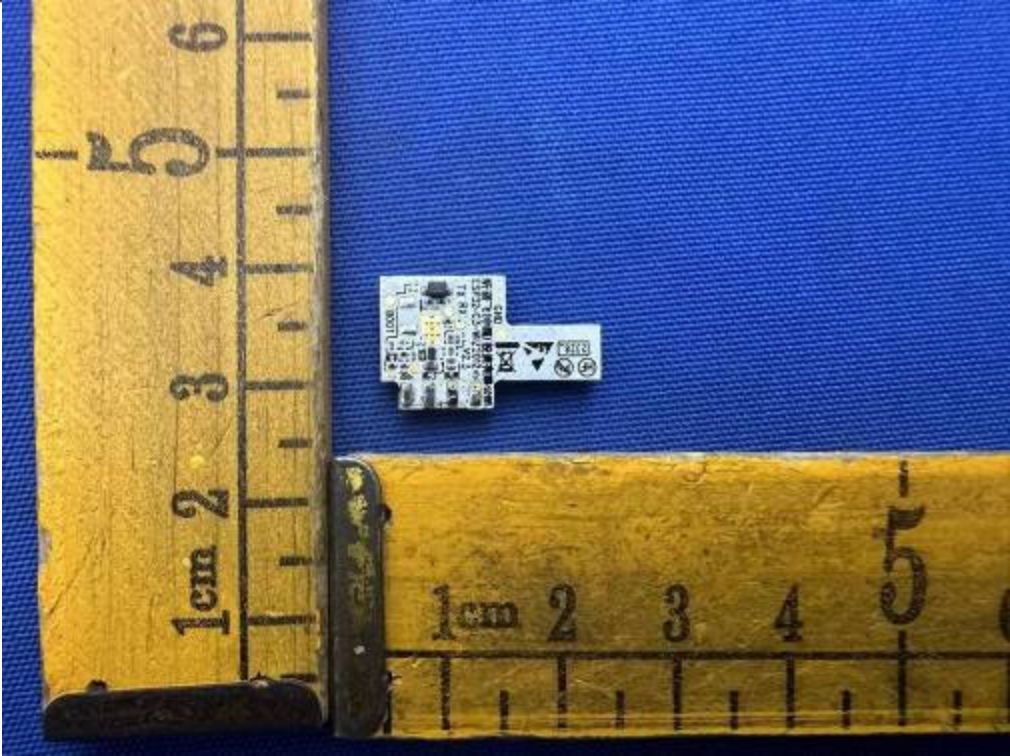



**--END OF REPORT--**